



GENERAL CATALOGUE



Gearboxes Made in Italy **2023**



In this catalogue

Rightangle-gear

Worm gearboxes

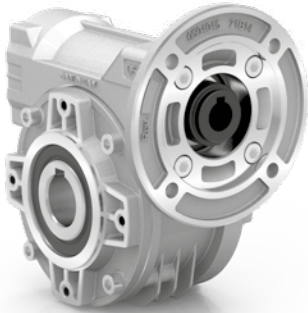

21÷978Nm

Paragraph **1**

M Square gear

Square worm gearboxes

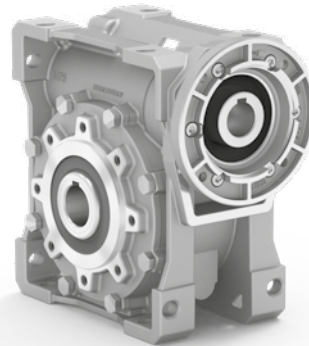

21÷1550Nm

Paragraph **2**

One step-gear

One step gearboxes

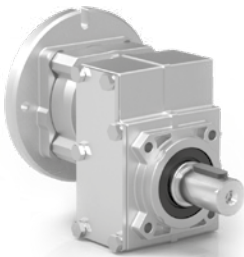

20÷110Nm

Paragraph **4**

Coaxial-gear

Aluminum gearboxes

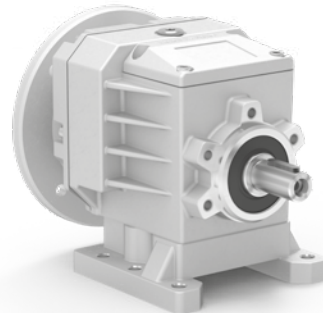

70÷520Nm

Paragraph **5**

Compact-gear

Shaft mounted gearboxes

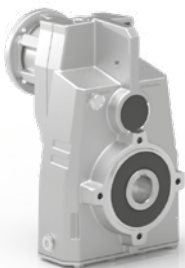

60÷2100Nm

Paragraph **7**

Cube-gear

Parallel shaft gearboxes

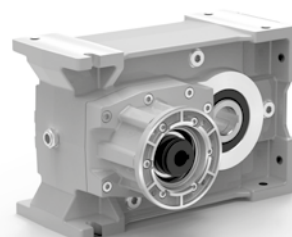

380÷2100Nm

Paragraph **8**

In this catalogue

Q Square gear

Square worm gearboxes

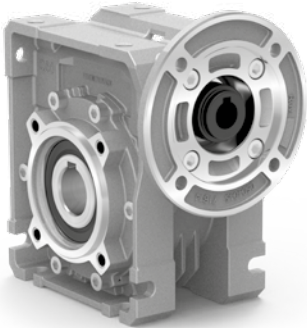

147÷978Nm

Paragraph 3

Paragraph 1

Paragraph 2

Paragraph 3

Paragraph 4

Coaxial-gear

Cast iron gearboxes

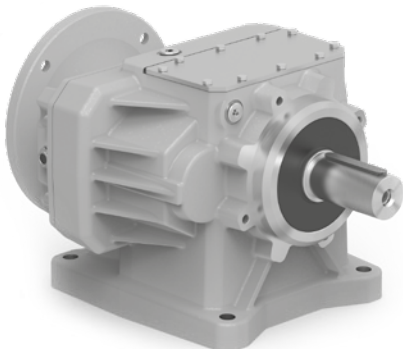

675÷4600Nm

Paragraph 6

Paragraph 5

Paragraph 6

Paragraph 7

Paragraph 8

Angletech-gear

Helical bevel gearboxes

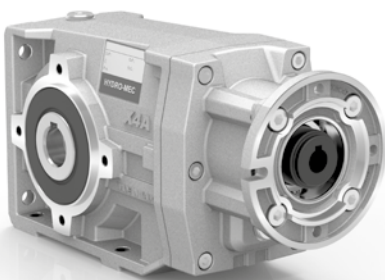

50÷4600Nm

Paragraph 9

Paragraph 9

Paragraph B

Paragraph M

Brushless motor flanges

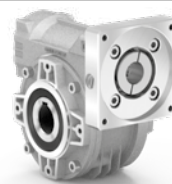

Paragraph B

Aluminum electric motors

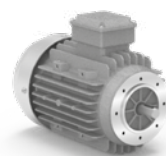

Paragraph M

Worm gearboxes

A modular and compact product

Single-piece aluminum alloy housing

Is vacuum impregnated (MIL-STD 276) for protection and sealing. No secondary finish required but readily accepts paint. Combines light weight with high tensile strength. Precision machined for alignment of bearings and gearing.

Single piece alloy steel input shaft and worm shaft.

High helix angle worm is case-hardened (Rc 58-60), ground, teeth are profiled and radiused, for noise reduction and enhanced efficiency.

Oversized bearings

Support positively-retained, high speed shaft for higher shock load capacity - ideal for frequent starting and reversing application. Premium, Nitrile® high temperature seals each end.

Bronze alloy worm gears.

CuSn12Ni (C91700) Nickel bronze worm gears are centrifugally cast onto an iron hub for maximum strength and superior life. Removable hollow shaft with key for safe torque transmissions.

Over-size bearing

For radial load capability and maximum hollow output shaft diameter.

Impregnated and machined bearing caps

With exterior machined surfaces enable a variety of mounting accessories. Extra-deep thread engagement provided for greater support strength. Zinc plated hardware.

Flange

Fully modular to IEC and compact integrated motor. NEMA C flange.

Premium, high temperature

Nitrile® output seals

Standard hollow output shaft mounting

Reduces total drive envelope size, weight and cost. Single and double solid output shaft is available.

Painting

Cast iron gearboxes are painted RAL 7046

Vent Free Design.

No breather or vents to leak! Factory lubricated for life with synthetic, semi-fluid gear lubricant with an operating range of -15°C to 130°C.

oil free



vent free



Specific type datasheet on page...

On page / A pagina / Auf Seite / À la page / En la página



Types / Tipi / Tipen / Types / Tipos →

1-5	1-7	1-9	1-11	1-13	1-15	1-17
030 21Nm	045 41Nm	050 72Nm	063 147Nm	63A 191Nm	085 347Nm	110 651Nm

On page / A pagina / Auf Seite / À la page / En la página

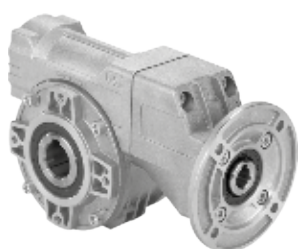

Types / Tipi / Tipen / Types / Tipos →

1-19	1-21	1-23	1-25	1-27	1-29
P45 55Nm	P50 88Nm	P63 187Nm	P6A 218Nm	P85 440Nm	P10 803Nm

On page / A pagina / Auf Seite / À la page / En la página



Types / Tipi / Tipen / Types / Tipos →

1-31	1-33	1-35	1-37	1-39	1-41	1-43	1-45	1-47
303 35Nm	453 69Nm	503 109Nm	633 230Nm	634 265Nm	6A3 290Nm	6A4 304Nm	854 518Nm	115 978Nm

On page / A pagina / Auf Seite / À la page / En la página

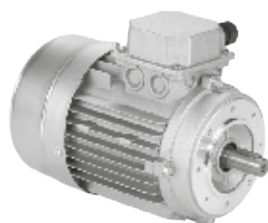

Types / Tipi / Tipen / Types / Tipos →

M-1										
56A 56B	63A 63B	71A 71B	80A 80B	90S 90L	100LA 100LB	112M	132S 132M	160M 160L	180M 180L	

Type - Tipo - Typ
Type - Tipo

Size - Grandezza
Grösse - Taille
Tamaño

Mounting - Montaggio - Montage Fixation
Fixation - Tipo de montaje

P

045

PA

Worm gearboxes

Riduttori a vite senza fine
Schneckengetriebe
Reducteurs a vis sans fin
Reductores de corona sin fin

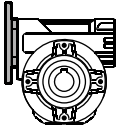

P

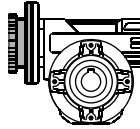

M

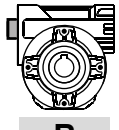

B

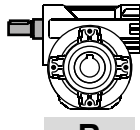

R

**030
045
050
063
63A
085
110**

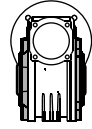

FB

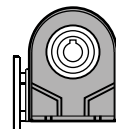

PB

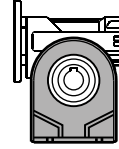

PA

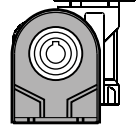

PV

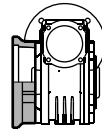

FC

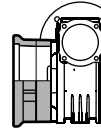

FL

**F1
F2
F3
F4**

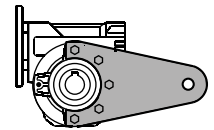

BR

Worm gearboxes with primary reduction

Riduttori a vite senza fine con precoppia
Schneckengetriebe mit Stirradstufe am Eintrieb
Reducteurs a vis sans fin avec pré-réduction
Reductores corona sin fin con prerreductora de engranajes

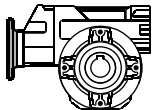

P

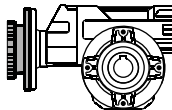

M

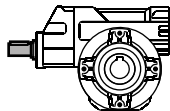

R

**P45
P50
P63
P6A
P85
P10**

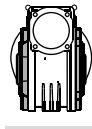

FB

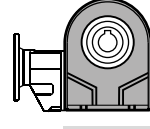

PB

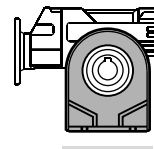

PA

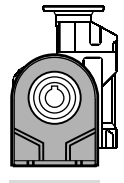

PV

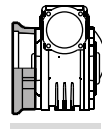

FC

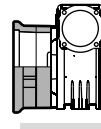

FL

**F1
F2
F3
F4**

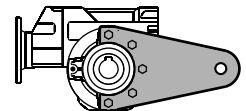

BR

Combined worm gearboxes

Riduttori a vite senza fine combinati
Schneckengetriebekombinationen
Reducteurs a double train de vis sans fin
Reductores combinados corona sin fin

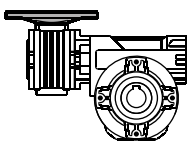

P

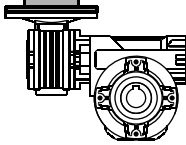

M

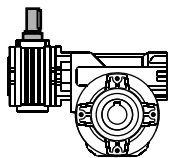

R

**303
453
503
633
634
6A3
6A4
854
115**

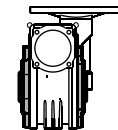

FB

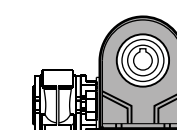

PB

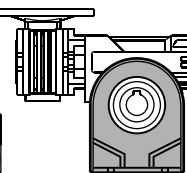

PA

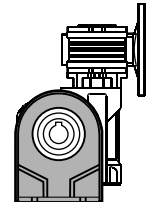

PV

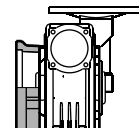

FC

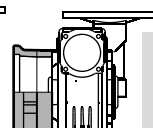

FL

**F1
F2
F3
F4**

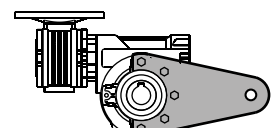









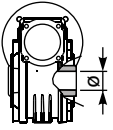
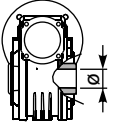
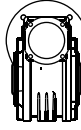

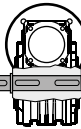
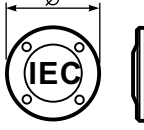
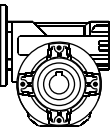
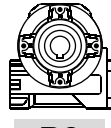
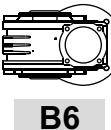
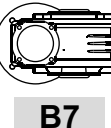

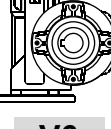
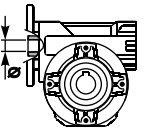
BR



On request we can deliver our products according to the ATEX
A richiesta possiamo fornire i nostri prodotti secondo le normative ATEX
Auf Anfrage können wir unsere Produkte den Richtlinien ATEX entsprechend liefern
Sur demande nos produits peuvent se conformer à la réglementation ATEX
A pedido, se pueden enviar nuestros productos de acuerdo con las normas ATEX.

CODIFICA / HOW TO ORDER / TYPENBEZEICHNUNGEN / CODIFICATION / CODIFICACIÓN

Ratio Rapporto Untersetzung Reduction Relación	Hub Mozzo corona Hohlwelle Arbre creux Nucleo corona	Output shaft Albero lento Abtriebswelle Arbre de sortie Eje salida	Motor size Grandezza motore Motor Grösse Grandeur moteur Tamaño motor	Mounting position Posizione montaggio Einbaulage Position de montage Posición de montaje	Input bore Foro entrata Eingangshohlwelle Trou d'entree Eje hueco de entrada	Mountin position Esecuzione montaggio Einbaulage Ejecución de montaje Posición de montaje	Terminal box position Posizione morsettieria Klemmkastenlage Position boîte a bornes Posición caja de bornes
10	C	Ø	-Q	B3	ST	---	
See technical data table Vedi tabella dati tecnici. Technisches Datenblatt beachten Voir tableau données techniques Ver tabla datos técnicos	 STANDARD C 030 ⇨ Ø14 045 ⇨ Ø18 050 ⇨ Ø25 063 ⇨ Ø25 63A ⇨ Ø28 085 ⇨ Ø35 110 ⇨ Ø42 I Stainless steel hub Mozzo in acciaio Inox Edelstahlhohlwelle Moyeu en acier Inox Nucleo corona de acero Inox SPECIAL SERIES SERIE SPECIALE S 045 ⇨ Ø19 050 ⇨ Ø24 X Stainless steel hub Mozzo in acciaio Inox Edelstahlhohlwelle Moyeu en acier Inox Nucleo corona de acero Inox  INCH U 045 ⇨ Ø0.750" 050 ⇨ Ø1.000" 063 ⇨ Ø1.125" 085 ⇨ Ø1.500" Z Stainless steel hub Mozzo in acciaio Inox Edelstahlhohlwelle Moyeu en acier Inox Nucleo corona de acero Inox	 Ø  S  D	 -M without flange Senza flangia B5 -A=56 (Ø120) -B=63 (Ø140) -C=71 (Ø160) -D=80 (Ø200) -E=90 (Ø200) -F=100 (Ø250) -G=132 (Ø300) B14 -O=56 (Ø80) -P=63 (Ø90) -Q=71 (Ø105) -R=80 (Ø120) -T=90 (Ø140) -U=100 (Ø160) -V=132 (Ø200) Brushless BA=40/63-M5 BB=50/70-M5 BC=60/75-M5 BD=70/90-M6 BE=80/100-M6 BF=95/115-M8 BG=110/145-M8 BH=130/165-M8 -0=Type R -S=Type R S series	 B3  B8  B6  B7  V5  V6	 ST Standard bore * Kit R standard Foro standard * Kit R standard Input bore without Reduction Bushing -O = 9mm -P = 11mm -Q = 14mm -R = 19mm -T = 24mm -U = 28mm -V = 38mm COUPLING STANDARD (IEC)  -A = 9mm -B = 11mm -C = 14mm -D = 19mm -E = 24mm -F = 28mm BRUSHLESS*  -1 = 9mm -2 = 11mm -3 = 14mm -4 = 19mm -5 = 22mm -6 = 24mm Ready for input coupling Predisposto per giunto  -0 Type B Tipo B  -0 Type R Tipo R	Only for combined units See technical data table Solo per i riduttori combinati Vedi tabella dati tecnici. Ausführungen für Getriebekombinationen it Uniquement pour combinés. Voir tableau données techniques Sólo para combinados ver tabla datos técnicos	With Type M specify terminal box position Con tipo M specificare posizione morsettieria  A  B STANDARD  C  D

* With reduction bushing where applicable
Con bussola di riduzione dove prevista

1

POTENZA RICHIESTA / REQUIRED POWER / ERFORDERLICHE LEISTUNG / PUISSANCE NECESSAIRE / POTENCIA NECESARIA

Lifting / sollevamento / hubantriebe / levage / elevación	$P [KW] = \frac{M [Kg] \cdot g [9.81] \cdot v [m / s]}{1000}$
Rotation / rotazione / drehung / rotation / rotação	$P [KW] = \frac{M [Nm] \cdot n [rpm]}{9550}$
Linear movement / traslazione / linearbewegung / translation / translación	$P [KW] = \frac{F [N] \cdot v [m / s]}{1000}$

TORQUE / COPPIA / DREHMOMENT / COUPLE / PAR

	$M [Nm] = \frac{9550 \cdot P[KW]}{n [rpm]}$
	$M [lb in] = \frac{63030 \cdot P[HP]}{n [rpm]}$

RADIAL LOADS / CARICHI RADIALI / RADIALE - UND AXIALLASTEN / CHARGES RADIALES / CARGA RADIAL Y AXIAL

- Radial load generated by external transmissions keyed onto input and/or output shafts.
- Forza radiale generata da organi di trasmissione calettati sugli alberi di ingresso e/o uscita.
- Belastungen der Antriebs- bzw. Abtriebswellen durch von aussen eingebrachte Radiallasten.
- Charge radiale générée par la transmissions calés sur les entrées et / ou des arbres de sortie
- Cargas radiales, generada por transmisiones externas, aplicadas sobre los ejes de entrada y/o salida

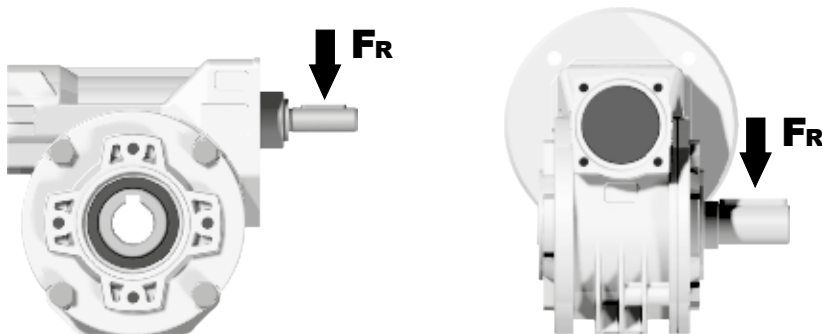

	$F_R [N] = \frac{M [Nm] \cdot 2000}{d [mm]} \cdot f_k$	$F_R [N] = \frac{M [lb in] \cdot 8.9}{d [in]} \cdot f_k$
M	Momento torcente / Output torque / Abtriebsdrehmoment / Couple / Par torsion	
d	Diametro primitivo / Diam. of driving element / Durchmesser der Abtriebseinheit / Diamètre primitif / Diámetro primitivo	
f_k	Coefficiente di trasformazione / Factor / Faktor / Coefficient de transmission / Coeficiente de transmisión 1.15 Ingranaggi / Gearwheels / Zahnrad / Engrenage / Engranaje 1.25 Catena / Chain sprockets / Antriebskette / Chaîne / Cadena 1.75 Cinghia Trapezoidale / Narrow v-belt pulley / Keilriemen / Courroie trap. / Correa trapezoidal 2.50 Cinghia piatta / Flat-belt pulley / Flachzahnriem. / Courroie crantée / Correa plana	

- If your application requires higher radial loads, contact our technical office. Higher load may be possible.
- Nel caso la vostra applicazione richieda carichi radiali superiori consultare il nostro ufficio tecnico, valori maggiori possono essere accettati.
- Wenn Ihre Anwendung höhere Radialbelastungen erfordert, so wenden Sie sich bitte an unser technischen Büro.
- Si votre application demande des charges radiales supérieures, s'adresser à notre bureau technique.
- En el caso en que una aplicación exija una carga radial superior a la especificada en el catálogo, consultar a nuestra oficinas técnica.

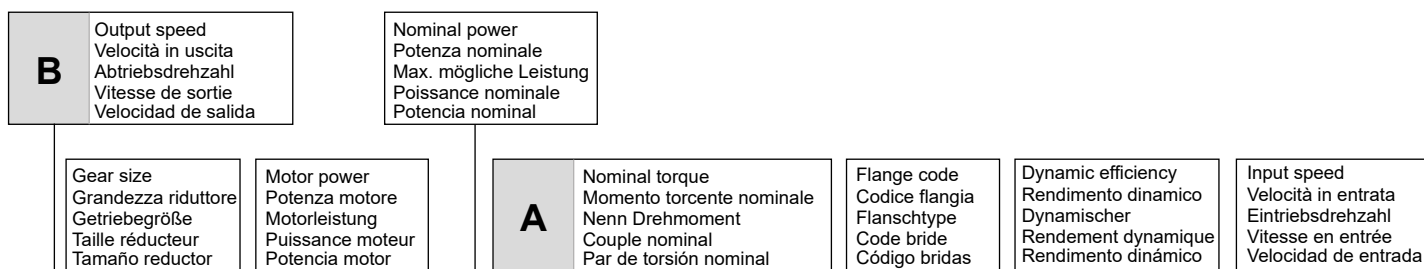

045 Rightangle - Gear
41Nm

Rating - Aluminum WORM GEARBOXES



QUICK SELECTION / Selezione veloce

input speed (n_1) = 1400 min⁻¹

Output Speed n_2 [min ⁻¹]	Ratio i	Motor power P_{1M} [kW]	Output torque M_{2M} [Nm]	Service factor f.s.	Nominal power P_{1R} [kW]	Nominal torque M_{2R} [Nm]	Available B5 motor flanges		Available B14 motor flanges			Dynamic efficiency RD	Tooth Module [mm]	Ratios code
							-B	-C	-O	-P	-Q			
200	7	0.37	14	2.2	0.80	30	B		B-C	B-C		80	2.2	01
140	10	0.37	20	1.5	0.57	30	B		B-C	B-C		79	2.2	02
100	14	0.37	27	1.1	0.41	30	B		B-C	B-C		77	2.4	03

C Ratio
Rapporto
Untersetzung
Rapport de réduction
Relación

Nominal module
Modulo nominale
Nenn modul
Module nominale
Módulo nominal

Notes
Note
Anmerkungen
Note
Notas

Transmitted torque
Momento torcente trasmesso
Mögliche Drehmomente
Couple de sortie
Par transmitido

Service factor
Fattore di servizio
Betriebsfaktor
Facteur de service
Factor de servicio

Type of load and starts per hour Tipo di carico e avviamenti per ora		Oper. hours per day Ore di funz. giorn.		
		<2 h	2 - 8 h	8 - 16 h
Continuous or intermittent appl. with start / hour Applicazione cont. o interm. con n.ro operazioni/ora	Uniform / Uniforme	0.9	1	1.25
	Moderate / Moderato	1	1.25	1.5
	Heavy / Forte	1.25	1.5	1.75
Intermittent application with start / hour Applicazione intermittente con n.ro operazioni/ora	Uniform / Uniforme	1.25	1.5	1.75
	Moderate / Moderato	1.5	1.75	2
	Heavy / Forte	1.75	2	2.25

D	Motor flange available Flange disponibili Erhältliche Motorflansche Brides disponibles Bridas disponibles	
B)	Mounting with reduction ring Montaggio con boccolla di riduzione Reduzierhülsen Montage avec douille de réduction Montaje con casquillo de reducción	
C)	Motor flangeholes position/terminal box position Posizione fori flangia/basetta motore Bohrungsposition am Motorflansch/-sockel Position trous bride/barrette à bornes moteur Posición agujeros brida / base motor	
B)	Available without reduction bushes Disponibile anche senza boccolla Auch ohne Reduzierbuchse verfügbar Disponible aussi sans douille de réduction Disponible tambien sin casquillo	

A	Select required torque (according to service factor)	Seleziona la coppia desiderata (comprensiva del fattore di servizio)	Max. Drehmoment in Bezug zum Betriebsfaktor	Sélectionner le couple souhaité (comprenant le facteur de service)	Seleccionar el par deseado (incluyendo el factor de servicio)
B	Select output speed	Seleziona la velocità in uscita	Ausgewählte Abtriebsdrehzahl	Sélectionner la vitesse de sortie	Seleccionar la velocidad de salida
C	On the same line of selected geared motor, you can find the gear ratio	Sulla riga corrispondente alla motorizzazione prescelta si può rilevare il rapporto di riduzione	Auf der gleichen Linie wie die ausgewählte Motorleistung steht auch die Getriebeuntersetzung	Sur la ligne correspondante à la motorisation pré-choisie on peut relever le rapport de réduction	En la línea correspondiente al motor preseleccionado es posible encontrar la relación de reducción
D	Select motor flange available (if requested)	Scegli la flangia disponibile (se richiesta)	Erhältliche Motorflansche (auf Anfrage)	Choisir la bride disponible (si elle est demandée)	Seleccionar la brida disponible (sobre pedido)

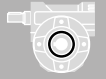

QUICK SELECTION / Selezione veloce

input speed (n_1) = 1400 min⁻¹

Output Speed n_2 [min ⁻¹]	Ratio i	Motor power P_{1M} [kW]	Output torque M_{2M} [Nm]	Service factor f.s.	Nominal power P_{1R} [kW]	Nominal torque M_{2R} [Nm]	Available B5 motor flanges		Available B14 motor flanges		Dynamic efficiency RD	Tooth Module [mm]	Ratios code
							-A	-B	-O	-P			
							56	63	56	63			
280	5	0.18	5	3.3	0.60	17	B		B-C		82	1.26	09
200	7	0.18	7	2.4	0.44	17	B		B-C		80	1.44	01
140	10	0.18	10	1.8	0.32	17	B		B-C		78	1.44	02
93	15	0.18	13	1.4	0.25	19	B		B-C		73	1.44	03
70	20	0.18	17	1.1	0.20	19	B		B-C		70	1.09	04
47	30	0.12	15	1.4	0.17	21	B		B-C		62	1.44	05
35	40	0.12	19	1.1	0.13	20	B		B-C		57	1.09	06
23	61	0.09	19	1.1	0.10	20	B		B-C		50	0.72	07
17.5	80	0.06	16	1.0	0.06	16	B		B-C		48	0.56	08
14	100	0.06*	16	0.5	0.03	8	B		B-C		40	0.45	10

A) Motor Flanges Available
Flange Motore Disponibili

B) Supplied with Reduction Bushing
Fornito con Bussola di Riduzione

B) Available on Request without reduction bushing
Disponibile a Richiesta senza Bussola di Riduzione

C) Motor Flange Holes Position
Posizione Fori Flangia Motore

* Power higher than the maximum one which can be supported by the gearbox. Select according to the torque M_{2R}
Potenza superiore a quella massima sopportabile dal riduttore. Selezionare in base al momento torcente M_{2R}

EN Unit 030 is supplied with synthetic oil, providing "long life" lubrication. For mounting position V5-V6 please contact us.
See table 1 for lubrication and recommended quantity. In table 2 please see possible radial loads and axial loads on the gearbox.

LUBRICATION 030 Oil Quantity 0.03 Lt.

SHELL Omala S4 WE 320

ENI Telium VSF 320

For all details on lubrication and plugs check our website **tab. 1**
Per maggiori dettagli su lubrificazione e tappi olio vedi il nostro sito web

I Il riduttore tipo 030 viene fornito lubrificato a vita con olio sintetico. Per posizioni V5-V6 contattare il ns. servizio tecnico.
Vedi tab.1 per oli e quantità consigliati. In tab.2 sono presenti i carichi radiali e assiali applicabili al riduttore.

D Für die Lebensdauerschmierung ist das Getriebe der Größe 030 mit synthetischem Öl befüllt. Bei Einbaulage V5 oder V6 bitten wir um Rücksprache. In Tabelle 1 ist die Schmiermenge und das empfohlene Schmiermittel angegeben. In Tabelle 2 sind die zulässigen Radial- und Axialbelastungen des Getriebes aufgeführt.

F Le réducteur de type 030 est fourni lubrifié à vie avec de l'huile synthétique. Concernant les positions V5.V6, contactez notre service d'assistance technique. Voir tableau 1 concernant les huiles et les quantités conseillées. Les charges radiales et axiales applicables au réducteur sont précisées dans le tableau 2.

E El reductor tamaño 030 se suministra, lubricado de por vida con aceite sintético. Para las posiciones V5 y V6 contactar con nuestro servicio técnico. Ver tabla 1, para cantidades y aceites recomendados. En la tabla 2, se encuentran las cargas radiales y axiales admitidas por el reductor.

RADIAL AND AXIAL LOADS

Output shaft

Albero di uscita

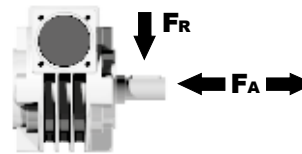

n_2 [min ⁻¹]	FA [N]	FR [N]
200	120	600
150	140	700
100	160	800
75	180	900
50	200	1000
25	250	1250
15	280	1400

Input shaft

albero in entrata

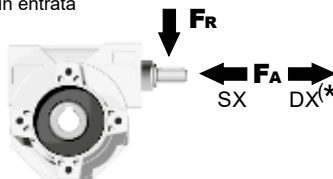

n_1 [min ⁻¹]	FA [N]	FR [N]
1400	20	100

*Strong axial loads in the DX direction are not allowed.
Non sono consentiti forti carichi assiali con direzione DX

tab. 2

P030FB... Basic wormbox
Riduttore base

Gearbox weight
peso riduttore **1.05 kg**

M. flanges	Kit code	øF	A
56B5	K030.4.041	120	61.5
63B5	K030.4.042	140	62.5
56B14	K030.4.046	80	61.5
63B14	K030.4.045	90	62.5

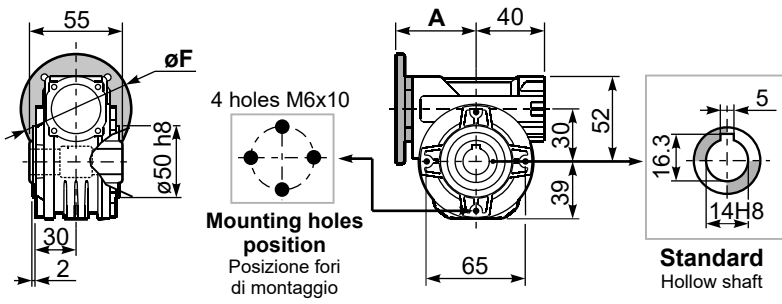

P030PA... Feet
Piedini

P030PB... Feet
Piedini

P030PV... Feet
Piedini

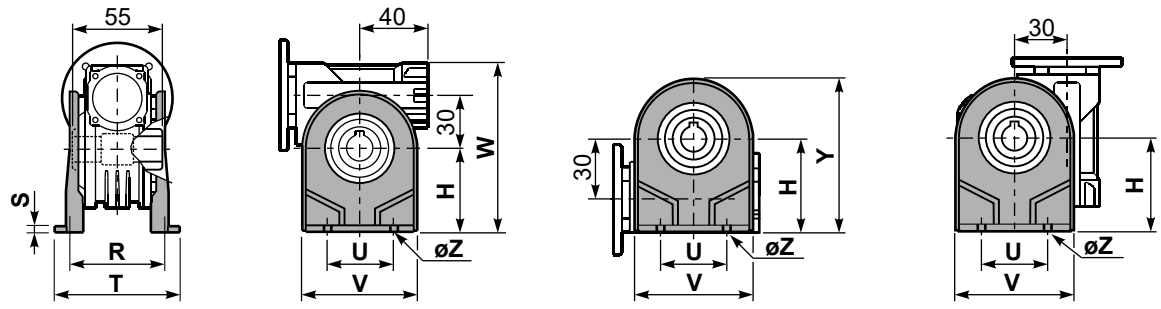

	H	R	S	T	U	V	Y	W	øZ	kit code
type B	55	66	3	87	50	90	94	107	ø6.5	K030.9.022
type S	52	66	3	87	52	90	91	104	ø6.5	KS030.9.023

P030FC... Output flange
Flangia uscita

P030BR... Reaction arm
Braccio di reazione

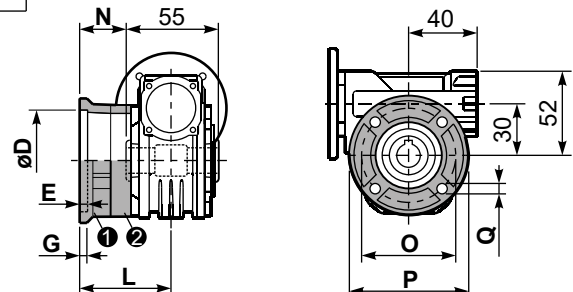

type B	øD	E	G	L	N	O	P	Q	kit code
FC	50 ^{+0.15} / _{+0.05}	6	6	50.5	23	68	80	7	① K030.9.010 ② -
FL	60 ^{+0.15} / _{+0.05}	6	6	55.5	28	87	110	8.5	① K045.9.010 ② -

type S	øD	E	G	L	N	O	P	Q	kit code
F1	40 ^{+0.15} / _{+0.10}	3.5	5.5	49	21.5	56	80	6.5	① KS030.9.012 ② -

P030.....S... Single Shaft
Albero lento semplice

P030.....D... Double Shaft
Albero lento bisp.

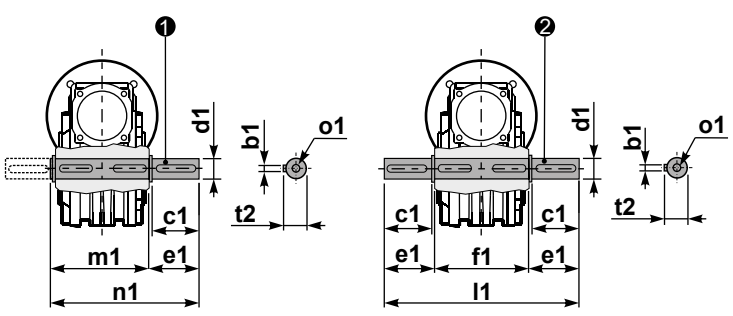

① kit cod. K030.5.028 type B ② kit cod. K030.5.029 type B

R030FB... Input shaft
Albero in entrata

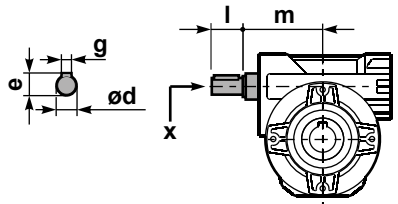

type	ød	e	g	l	m	x	kit code
type B	9 h6	10.2	3	20	58	-	K030.5.006 PAM63
type S	-	-	-	-	-	-	-

type	b1	c1	d1	e1	f1	l1	m1	n1	t2	o1
type B	5	25	14 ^{-0.005} / _{-0.020}	35.5	55	126	59	94.5	16	M5x14
type S	-	-	-	-	-	-	-	-	-	-



QUICK SELECTION / Selezione veloce

input speed (n_1) = 1400 min⁻¹

Output Speed n_2 [min ⁻¹]	Ratio i	Motor power P_{1M} [kW]	Output torque M_{2M} [Nm]	Service factor f.s.	Nominal power P_{1R} [kW]	Nominal torque M_{2R} [Nm]	Available B5 motor flanges		Available B14 motor flanges			Dynamic efficiency RD	Tooth Module [mm]	Ratios code
							-B	-C	-O	-P	-Q			
							63	71	56	63	71			
200	7	0.37	14	2.2	0.80	30	B		B-C	B-C		80	2.2	01
140	10	0.37	20	1.5	0.57	30	B		B-C	B-C		79	2.2	02
100	14	0.37	27	1.1	0.41	30	B		B-C	B-C		77	2.4	03
67	21	0.37	36	1.2	0.43	41	B		B-C	B-C		67	1.6	04
50	28	0.25	31	1.3	0.33	41	B		B-C	B-C		65	2.5	05
38	37	0.25	40	1.0	0.26	41	B		B-C	B-C		63	1.8	06
30	46	0.25	46	0.9	0.22	41	B		B-C	B-C		59	1.5	07
23	60	0.18	41	1.0	0.18	41	B		B-C	B-C		56	1.2	08
20	70	0.12	31	1.0	0.12	30	B		B-C	B-C		54	1.0	09
13.7	102	0.09	31	1.0	0.09	29	B		B-C	B-C		49	0.72	10

A Motor Flanges Available
Flange Motore Disponibili

B Supplied with Reduction Bushing
Fornito con Bussola di Riduzione

B Available on Request without reduction bushing
Disponibile a Richiesta senza Bussola di Riduzione

C Motor Flange Holes Position
Posizione Fori Flangia Motore

EN Unit **045** is supplied with synthetic oil, providing "long life" lubrication. For mounting position V5-V6 please contact us. See table 1 for lubrication and recommended quantity. In table 2 please see possible radial loads and axial loads on the gearbox.

I Il riduttore tipo **045** viene fornito lubrificato a vita con olio sintetico. Per posizioni V5-V6 contattare il ns. servizio tecnico. Vedi tab.1 per oli e quantità consigliati. In tab.2 sono presenti i carichi radiali e assiali applicabili al riduttore.

D Für die Lebensdauerschmierung ist das Getriebe der Größe **045** mit synthetischem Öl befüllt. Bei Einbaulage V5 oder V6 bitten wir um Rücksprache. In Tabelle 1 ist die Schmiermenge und das empfohlene Schmiermittel angegeben. In Tabelle 2 sind die zulässigen Radial - und Axialbelastungen des Getriebes aufgeführt.

F Le réducteur de type **045** est fourni lubrifié à vie avec de l'huile synthétique. Concernant les positions V5.V6, contactez notre service d'assistance technique. Voir tableau 1 concernant les huiles et les quantités conseillées. Les charges radiales et axiales applicables au réducteur sont précisées dans le tableau 2.

E El reductor tamaño **045** se suministra, lubricado de por vida con aceite sintético. Para las posiciones V5 y V6 contactar con nuestro servicio técnico. Ver tabla 1, para cantidades y aceites recomendados. En la tabla 2, se encuentran las cargas radiales y axiales admitidas por el reductor.

LUBRICATION 045 Oil Quantity 0.09 Lt.

SHELL Omala S4 WE 320

ENI Telium VSF 320

For all details on lubrication and plugs check our website **tab. 1**
Per maggiori dettagli su lubrificazione e tappi olio vedi il nostro sito web

RADIAL AND AXIAL LOADS

Output shaft
Albero di uscita

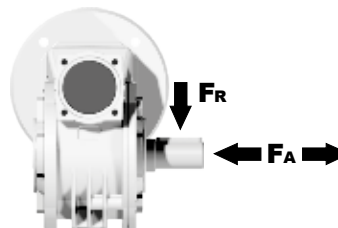

n_2 [min ⁻¹]	FA [N]	FR [N]
200	180	900
150	200	1000
100	220	1100
75	240	1200
50	260	1400
25	300	1800
15	400	2000

Input shaft
albero in entrata

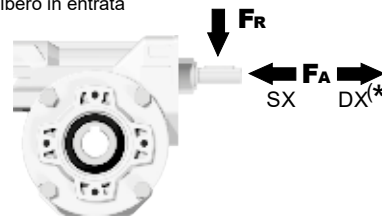

n_1 [min ⁻¹]	FA [N]	FR [N]
1400	42	210

*Strong axial loads in the DX direction are not allowed.
Non sono consentiti forti carichi assiali con direzione DX

tab. 2

P045FB... Basic wormbox
Riduttore base

Gearbox weight
peso riduttore **2.40 kg**

M. flanges	Kit code	øF	A
63B5	K050.4.041	138	74
71B5	K050.4.042	160	71.5
56B14	KC40.4.049	80	71.5
63B14	K050.4.047	90	74
71B14	K050.4.045	105	71.5

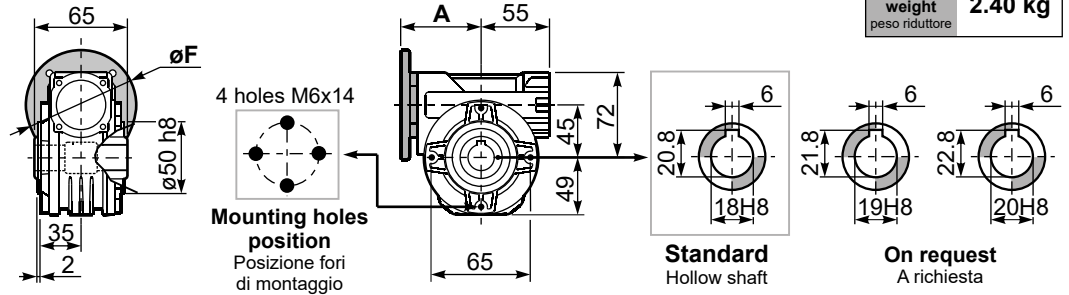

Standard
Hollow shaft

On request
A richiesta

P045PA... Feet
Piedini

P045PB... Feet
Piedini

P045PV... Feet
Piedini

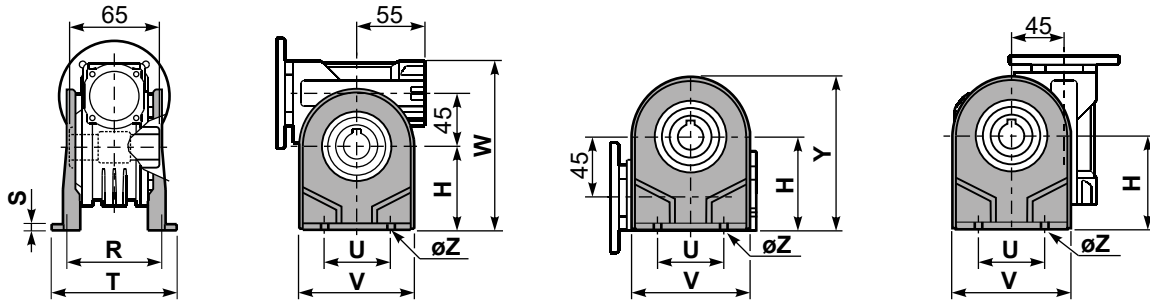

	H	R	S	T	U	V	Y	W	øZ	kit code
type B	72	81	3	100	52	98	121	144	ø10.5	K045.9.022
type S	71	84	8	100	70	90	120	143	ø8	KS045.9.023

P045FC... Output flange
Flangia uscita

P045BR... Reaction arm
Braccio di reazione

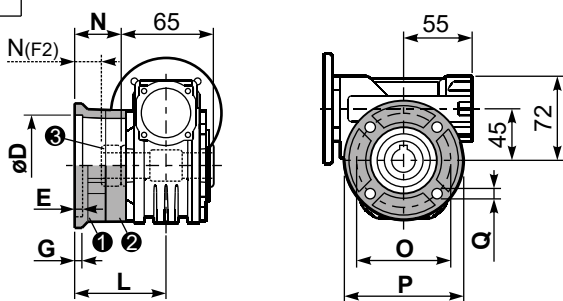

type B	øD	E	G	L	N	O	P	Q	kit code
FC	60 ^{+0.15} / _{+0.05}	9	9	60.5	28	87	110	8.5	1 K045.9.010 2 -
FL	60 ^{+0.15} / _{+0.05}	9	9	90.5	58	87	110	8.5	1 K045.9.010 2 K045.0.200

type S	øD	E	G	L	N	O	P	Q	kit code
F1	95 ^{+0.20} / _{+0.15}	4	11	73.5	41	115	140	9	1 KS045.9.013 2 -
F2	60 ^{+0.15} / _{+0.05}	9	9	60.5	19	87	110	8.5	1 KS045.9.010 2 S045.0.204
F3	80 ^{+0.15} / _{+0.10}	3	8	51.5	19	100	120	9	1 KS045.9.014 2 -

P045.....S... Single Shaft
Albero lento semplice

P045.....D... Double Shaft
Albero lento bisp.

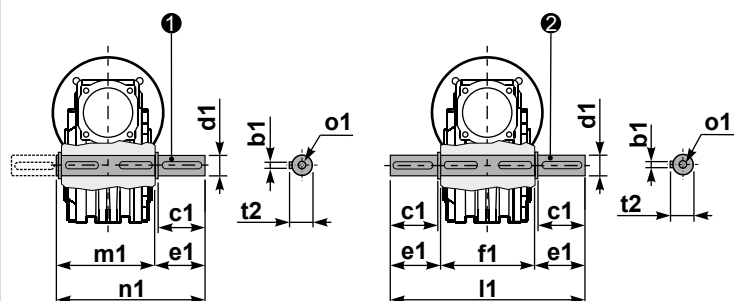

1 kit cod. K045.5.028 type B
kit cod. KS045.5.030 type S

2 kit cod. K045.5.029 type B

R045FB... Input shaft
Albero in entrata

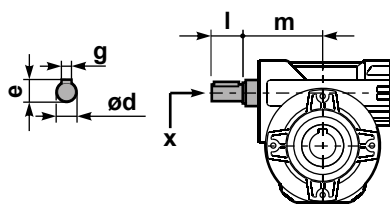

	ød	e	g	l	m	x	kit code
type B	11 h6	12.5	4	30	68	-	1 K045.5.006 PAM71 2 -
type S	-	-	-	-	-	-	1 - 2 -

	b1	c1	d1	e1	f1	l1	m1	n1	t2	o1
type B	6	32	18 ^{-0.005} / _{-0.020}	43	65	151	70	113	20.5	M6x18
type S	6	40	19 ^{-0.005} / _{-0.020}	58.8	-	-	70	128.5	21.5	M8x20



QUICK SELECTION / Selezione veloce

input speed (n_1) = 1400 min⁻¹

Output Speed n_2 [min ⁻¹]	Ratio i	Motor power P_{1M} [kW]	Output torque M_{2M} [Nm]	Service factor f.s.	Nominal power P_{1R} [kW]	Nominal torque M_{2R} [Nm]	Available B5 motor flanges			Available B14 motor flanges				Dynamic efficiency RD	Tooth Module [mm]	Ratios code
							-B	-C	-D	-O	-P	-Q	-R			
							63	71	80	56	63	71	80			
200	7	0.75	29	1.9	1.5	57	B	B			B-C	B		82	2.5	01
140	10	0.75	41	1.5	1.1	62	B	B			B-C	B		80	2.4	02
100	14	0.75	57	1.2	0.90	68	B	B			B-C	B		79	2.6	03
78	18	0.55	51	1.2	0.67	62	B	B			B-C	B		75	2.0	04
54	26	0.55	67	1.0	0.54	66	B	B			B-C	B		69	2.7	05
47	30	0.55	79	0.9	0.50	72	B	B			B-C	B		70	2.5	12
39	36	0.37	63	1.2	0.43	72	B			B-C	B-C			69	2.1	06
33	43	0.37	72	1.0	0.35	68	B			B-C	B-C			66	1.8	07
28	50	0.25	53	1.2	0.31	66	B			B-C	B-C			62	1.5	13
23	60	0.25	59	1.0	0.26	62	B			B-C	B-C			58	1.3	08
21	68	0.25	66	0.9	0.22	58	B			B-C	B-C			57	1.2	09
17.5	80	0.18	53	1.1	0.19	57	B			B-C	B-C			54	1.0	10
14	100	0.12	41	1.3	0.15	51	B			B-C	B-C			50	0.8	11

A) Motor Flanges Available
Flange Motore Disponibili

B) Supplied with Reduction Bushing
Fornito con Bussola di Riduzione

B) Available on Request without reduction bushing
Disponibile a Richiesta senza Bussola di Riduzione

C) Motor Flange Holes Position
Posizione Fori Flangia Motore

EN Unit 050 is supplied with synthetic oil, providing "long life" lubrication. For mounting position V5-V6 please contact us. See table 1 for lubrication and recommended quantity. In table 2 please see possible radial loads and axial loads on the gearbox.

I Il riduttore tipo 050 viene fornito lubrificato a vita con olio sintetico. Per posizioni V5-V6 contattare il ns. servizio tecnico. Vedi tab.1 per oli e quantità consigliati. In tab.2 sono presenti i carichi radiali e assiali applicabili al riduttore.

D Für die Lebensdauerschmierung ist das Getriebe der Größe 050 mit synthetischem Öl befüllt. Bei Einbaulage V5 oder V6 bitten wir um Rücksprache. In Tabelle 1 ist die Schmiermenge und das empfohlene Schmiermittel angegeben. In Tabelle 2 sind die zulässigen Radial - und Axialbelastungen des Getriebes aufgeführt.

F Le réducteur de type 050 est fourni lubrifié à vie avec de l'huile synthétique. Concernant les positions V5.V6, contactez notre service d'assistance technique. Voir tableau 1 concernant les huiles et les quantités conseillées. Les charges radiales et axiales applicables au réducteur sont précisées dans le tableau 2.

E El reductor tamaño 050 se suministra, lubricado de por vida con aceite sintético. Para las posiciones V5 y V6 contactar con nuestro servicio técnico. Ver tabla 1, para cantidades y aceites recomendados. En la tabla 2, se encuentran las cargas radiales y axiales admitidas por el reductor.

LUBRICATION 050 Oil Quantity 0.14 Lt.

SHELL Omala S4 WE 320

ENI Telium VSF 320

For all details on lubrication and plugs check our website **tab. 1**
Per maggiori dettagli su lubrificazione e tappi olio vedi il nostro sito web

RADIAL AND AXIAL LOADS

Output shaft

Albero di uscita

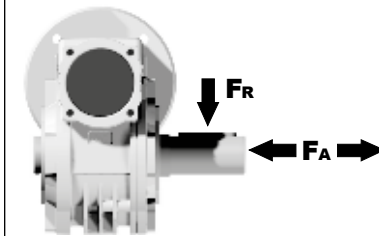

n_2 [min ⁻¹]	FA [N]	FR [N]
200	240	1200
150	280	1400
100	300	1500
75	340	1700
50	380	1900
25	480	2500
15	560	2800

Input shaft

albero in entrata

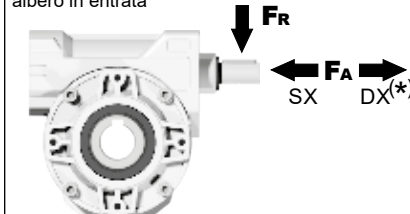

n_1 [min ⁻¹]	FA [N]	FR [N]
1400	76	380

*Strong axial loads in the DX direction are not allowed.
Non sono consentiti forti carichi assiali con direzione DX

tab. 2

P050FB... Basic wormbox
Riduttore base

Gearbox weight
peso riduttore **3.00 kg**

M. flanges	Kit code	øF	A
63B5	K050.4.041	138	78.5
71B5	K050.4.042	160	76
80B5	K050.4.043	200	76.5
56B14	KC40.4.049	80	76
63B14	K050.4.047	90	78.5
71B14	K050.4.045	105	76
80B14	K050.4.046	120	76.5

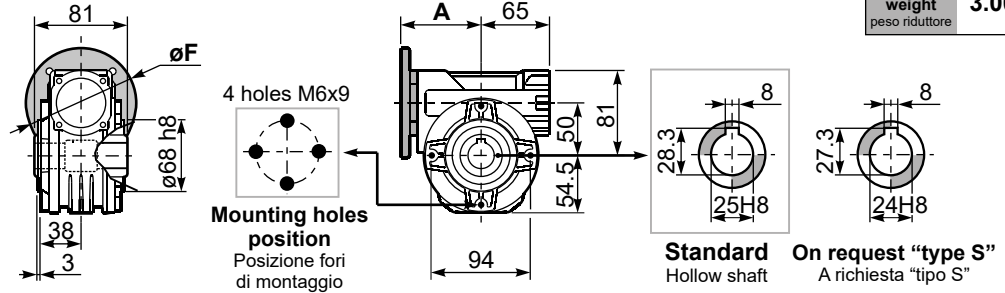

P050PA... Feet
Piedini

P050PB... Feet
Piedini

P050PV... Feet
Piedini

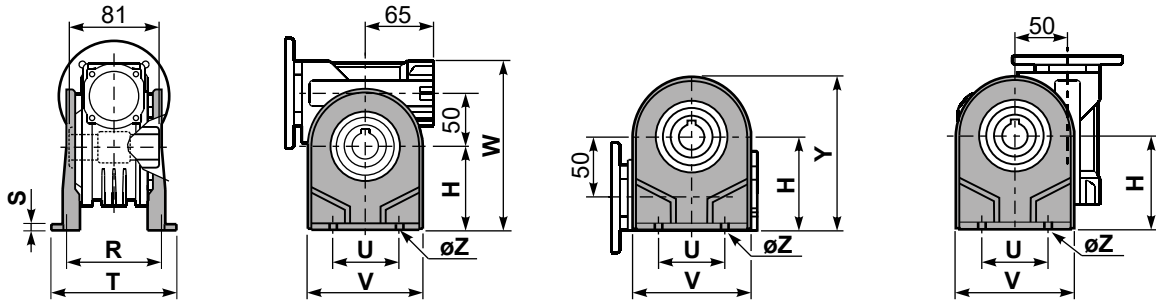

	H	R	S	T	U	V	Y	W	øZ	kit code
type B	82	98.5	3.5	123	63	113	138.5	163	ø10.5	K050.9.022
type S	85	96	10	114	85	110	139.5	166	ø10	KS050.9.023

P050FC... Output flange
Flangia uscita

P050BR... Reaction arm
Braccio di reazione

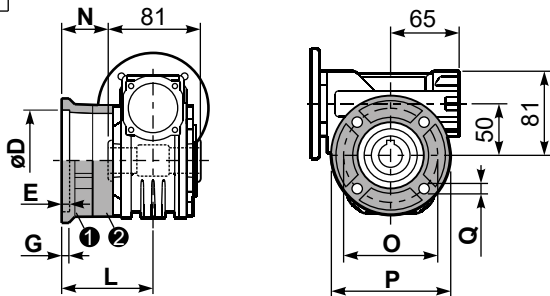

type B	øD	E	G	L	N	O	P	Q	kit code
FC	70 ^{+0.20} / _{+0.15}	9	12	85	44.5	90	123	10.5	① K050.9.010 ② -
FL	70 ^{+0.20} / _{+0.15}	9	12	114.5	74	90	123	10.5	① K050.9.010 ② K050.0.200
type S	øD	E	G	L	N	O	P	Q	kit code
F1	110 ^{+0.20} / _{+0.15}	4	11	83.5	43	130	160	10	① KS050.9.012 ② -
F2	70 ^{+0.20} / _{+0.15}	9	12	76.5	36	90	123	10.5	① KS050.9.014 ② -
F3	95 ^{+0.035} / ₀	4	10	66.5	26	115	140	10	① KS050.9.013 ② -

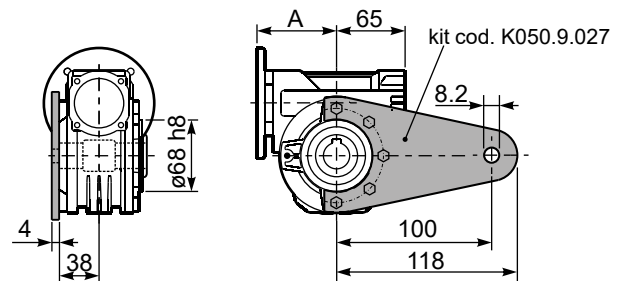

P050.....S... Single Shaft
Albero lento semplice

P050.....D... Double Shaft
Albero lento bisp.

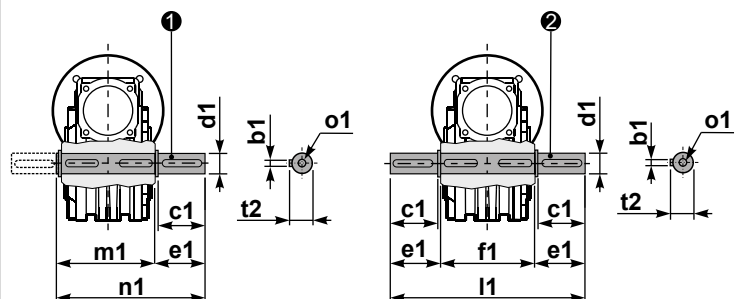

① kit cod. K050.5.028 type B
kit cod. KS050.5.030 type S

② kit cod. K050.5.029 type B

R050FB... Input shaft
Albero in entrata

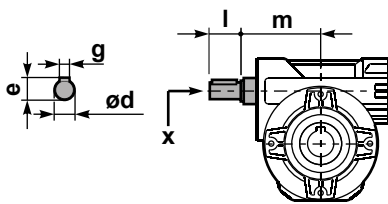

	ød	e	g	l	m	x	kit code
type B	16 h6	18	5	30	74.5	M6x16	① K050.5.006 PAM71 ② K050.5.007 PAM80
type S	14 h6	16	5	30	74.5	M5x10	① KS050.5.008 PAM71 ② KS050.5.009 PAM80

	b1	c1	d1	e1	f1	l1	m1	n1	t2	o1
type B	8	52	25 ^{-0.005} / _{-0.020}	59.5	81	200	86.5	146	28	M8x20
type S	8	50	24 ^{-0.005} / _{-0.020}	68.8	-	-	86.5	155	27	M8x20



QUICK SELECTION / Selezione veloce

input speed (n_1) = 1400 min⁻¹

Output Speed n_2 [min ⁻¹]	Ratio i	Motor power P_{1M} [kW]	Output torque M_{2M} [Nm]	Service factor f.s.	Nominal power P_{1R} [kW]	Nominal torque M_{2R} [Nm]	Available B5 motor flanges				Available B14 motor flanges			Dynamic efficiency RD	Tooth Module [mm]	Ratios code 	
							-B	-C	-D	-E	-Q	-R	-T				
							63	71	80	90	71	80	90				
200	7	1.8	71	1.8	3.2	125		B	B			B-C	B-C		83	3.1	01
140	10	1.8	99	1.4	2.4	134		B	B			B-C	B-C		81	3.1	02
93	15	1.5	121	1.1	1.7	138		B	B			B-C	B-C		79	3.1	03
74	19	1.1	111	1.2	1.4	138		B	B			B-C	B-C		78	2.6	04
58	24	1.1	135	1.0	1.2	142		B	B			B-C	B-C		75	2.0	05
47	30	1.1	167	0.9	0.96	146		B	B			B-C	B-C		74	3.2	06
39	36	0.75	125	1.2	0.88	147		B	B			B-C	B-C		68	2.7	07
35	40	0.75	135	1.0	0.78	140		B	B	B		B-C	B-C		66	2.5	13
31	45	0.55	111	1.2	0.67	135	B	B				B-C	C		66	2.1	08
23	60	0.55	140	0.9	0.51	130	B	B				B-C	C		62	1.6	12
21	67	0.55	151	0.8	0.45	124	B	B				B-C	C		60	1.5	09
17.5	80	0.37	115	1.0	0.38	119	B	B				B-C	C		57	1.3	10
14.9	94	0.37	123	1.0	0.36	119	B	B				B-C	C		52	1.1	11

Motor Flanges Available
Flange Motore Disponibili

B) Supplied with Reduction Bushing
Fornito con Bussola di Riduzione

B) Available on Request without reduction bushing
Disponibile a Richiesta senza Bussola di Riduzione

C) Motor Flange Holes Position
Posizione Fori Flangia Motore

EN Unit **063** is supplied with synthetic oil, providing "long life" lubrication. For mounting position V5-V6 please contact us. See table 1 for lubrication and recommended quantity. In table 2 please see possible radial loads and axial loads on the gearbox.

I Il riduttore tipo **063** viene fornito lubrificato a vita con olio sintetico. Per posizioni V5-V6 contattare il ns. servizio tecnico. Vedi tab.1 per oli e quantità consigliati. In tab.2 sono presenti i carichi radiali e assiali applicabili al riduttore.

D Für die Lebensdauerschmierung ist das Getriebe der Größe **063** mit synthetischem Öl befüllt. Bei Einbaulage V5 oder V6 bitten wir um Rücksprache. In Tabelle 1 ist die Schmiermenge und das empfohlene Schmiermittel angegeben. In Tabelle 2 sind die zulässigen Radial- und Axialbelastungen des Getriebes aufgeführt.

F Le réducteur de type **063** est fourni lubrifié à vie avec de l'huile synthétique. Concernant les positions V5.V6, contactez notre service d'assistance technique. Voir tableau 1 concernant les huiles et les quantités conseillées. Les charges radiales et axiales applicables au réducteur sont précisées dans le tableau 2.

E El reductor tamaño **063** se suministra, lubricado de por vida con aceite sintético. Para las posiciones V5 y V6 contactar con nuestro servicio técnico. Ver tabla 1, para cantidades y aceites recomendados. En la tabla 2, se encuentran las cargas radiales y axiales admitidas por el reductor.

LUBRICATION 063 Oil Quantity 0.40 Lt.

SHELL Omala S4 WE 320

ENI Telium VSF 320

For all details on lubrication and plugs check our website **tab. 1**
Per maggiori dettagli su lubrificazione e tappi olio vedi il nostro sito web

RADIAL AND AXIAL LOADS

Output shaft
Albero di uscita

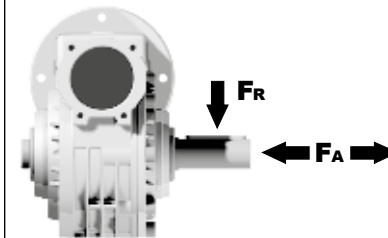

n_2 [min ⁻¹]	FA [N]	FR [N]
200	360	1800
150	400	2000
100	460	2300
75	500	2500
50	600	3000
25	700	3800
15	800	4000

Input shaft
albero in entrata

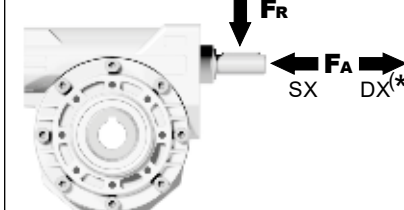

n_1 [min ⁻¹]	FA [N]	FR [N]
1400	90	450

*Strong axial loads in the DX direction are not allowed.
Non sono consentiti forti carichi assiali con direzione DX

tab. 2

P063FB... Basic wormbox
Riduttore base

Gearbox weight
peso riduttore **6.00 kg**

M. flanges	Kit code	øF	A
63B5	K063.4.041	140	99.5
71B5	K063.4.042	160	97.5
80/90B5	K063.4.043	200	99.5
71B14	K063.4.047	105	97.5
80B14	K063.4.046	120	99.5
90B14	K063.4.041	140	99.5

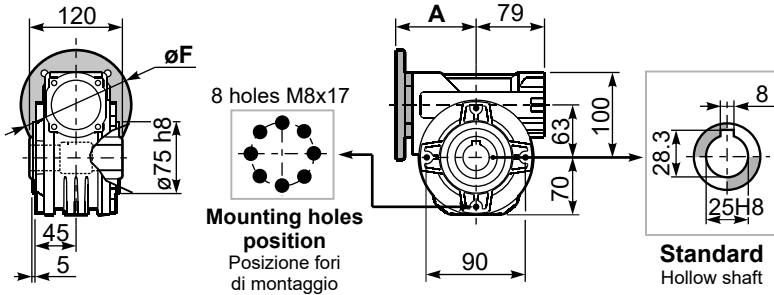

Standard
Hollow shaft

P063PA... Feet
Piedini

P063PB... Feet
Piedini

P063PV... Feet
Piedini

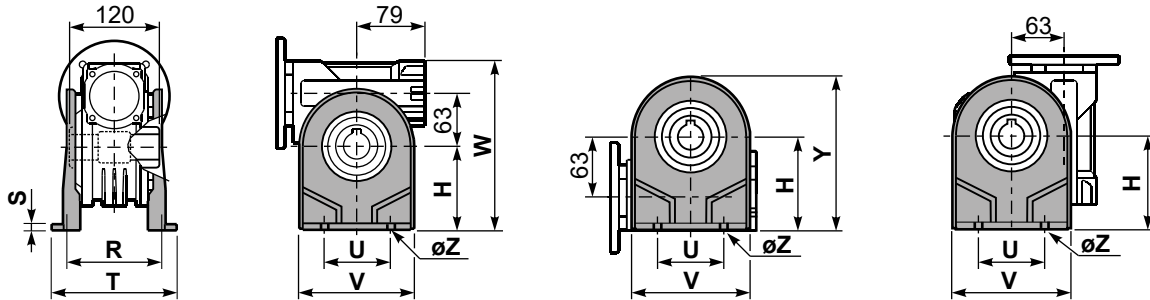

	H	R	S	T	U	V	Y	W	øZ	kit code
type B	100	111	4	144	95	133	170	200	ø10.5	K063.9.022
type S	-	-	-	-	-	-	-	-	-	-

P063FC... Output flange
Flangia uscita

P063BR... Reaction arm
Braccio di reazione

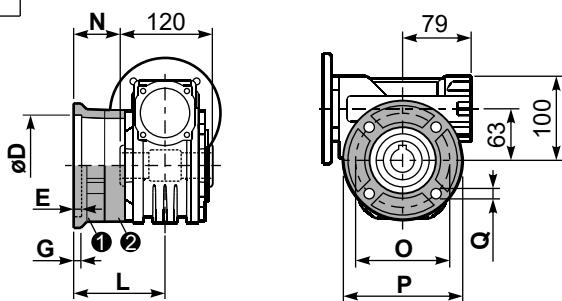

type B	øD	E	G	L	N	O	P	Q	kit code
FC	115 ^{+0.20} / _{+0.15}	7	13	86	26	150	175	11	① K063.9.010 ② -
FL	115 ^{+0.20} / _{+0.15}	7	13	116	56	150	175	11	① K063.9.010 ② K063.0.200

type S	øD	E	G	L	N	O	P	Q	kit code
F1	130 ^{+0.20} / _{+0.15}	7	13	102	42	165	200	13	① KS070.9.013 ② -
F2	115 ^{+0.20} / _{+0.15}	7	13	116	56	150	175	11	① KS063.9.013 ② -
F3	110 ^{+0.035} / ₀	5	11	82	22	130	160	10	① KS063.9.011 ② -

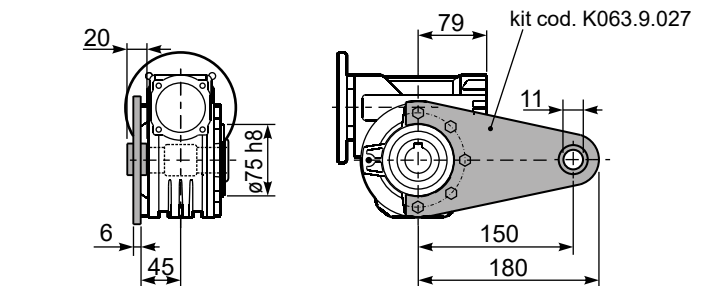

P063.....S... Single Shaft
Albero lento semplice

P063.....D... Double Shaft
Albero lento bisp.

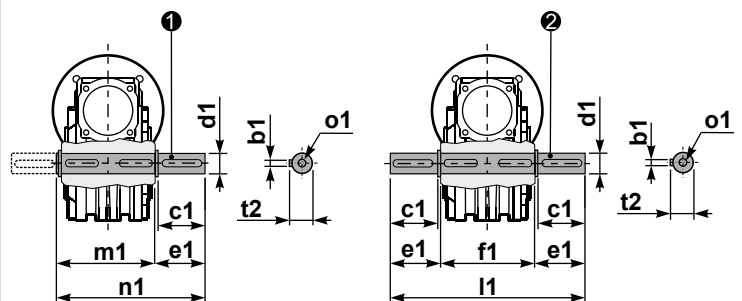

① kit cod. K063.5.028 type B

② kit cod. K063.5.029 type B

R063FB... Input shaft
Albero in entrata

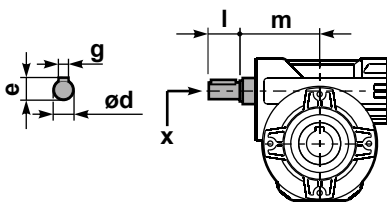

	ød	e	g	l	m	x	kit code
type B	18 h6	20.5	6	45	93	M6x16	① K063.5.006 PAM80 ② K063.5.007 PAM90
type S	19 h6	21.5	6	40	93	M8x20	① KS063.5.008 PAM80 ② KS063.5.009 PAM90

	b1	c1	d1	e1	f1	l1	m1	n1	t2	o1
type B	8	60	25 ^{-0.005} / _{-0.020}	63.2	120	246.4	126.8	190	28	M8x20
type S	-	-	-	-	-	-	-	-	-	-

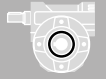

QUICK SELECTION / Selezione veloce

input speed (n_1) = 1400 min⁻¹

Output Speed n_2 [min ⁻¹]	Ratio i	Motor power P_{1M} [kW]	Output torque M_{2M} [Nm]	Service factor f.s.	Nominal power P_{1R} [kW]	Nominal torque M_{2R} [Nm]	Available B5 motor flanges				Available B14 motor flanges			Dynamic efficiency RD	Tooth Module [mm]	Ratios code 	
							-B	-C	-D	-E	-Q	-R	-T				
							63	71	80	90	71	80	90				
200	7	1.8	71	2.3	4.1	162		B	B			B-C	B-C		83	3.1	01
140	10	1.8	99	1.7	3.1	173		B	B			B-C	B-C		81	3.1	02
93	15	1.5	121	1.5	2.2	178		B	B			B-C	B-C		79	3.1	03
74	19	1.5	152	1.2	1.8	178		B	B			B-C	B-C		78	2.6	04
58	24	1.5	184	1.0	1.5	185		B	B			B-C	B-C		75	2.0	05
47	30	1.5	227	0.8	1.3	189		B	B			B-C	B-C		74	3.2	06
39	36	1.1	184	1.0	1.1	191		B	B			B-C	B-C		68	2.7	07
35	40	1.1	198	0.9	1.0	181		B	B			B-C	B-C		66	2.5	13
31	45	0.75	152	1.2	0.86	175	B	B				B-C	C		66	2.1	08
23	60	0.55	140	1.2	0.66	168	B	B				B-C	C		62	1.6	12
21	67	0.55	151	1.1	0.58	159	B	B				B-C	C		60	1.5	09
17.5	80	0.37	115	1.3	0.49	153	B	B				B-C	C		57	1.3	10
14.9	94	0.37	123	1.1	0.39	130	B	B				B-C	C		52	1.1	11

Motor Flanges Available
Flange Motore Disponibili

B) Supplied with Reduction Bushing
Fornito con Bussola di Riduzione

B) Available on Request without reduction bushing
Disponibile a Richiesta senza Bussola di Riduzione

C) Motor Flange Holes Position
Posizione Fori Flangia Motore

EN Unit **63A** is supplied with synthetic oil, providing "long life" lubrication. For mounting position V5-V6 please contact us. See table 1 for lubrication and recommended quantity. In table 2 please see possible radial loads and axial loads on the gearbox.

I Il riduttore tipo **63A** viene fornito lubrificato a vita con olio sintetico. Per posizioni V5-V6 contattare il ns. servizio tecnico. Vedi tab.1 per oli e quantità consigliati. In tab.2 sono presenti i carichi radiali e assiali applicabili al riduttore.

D Für die Lebensdauerschmierung ist das Getriebe der Größe **63A** mit synthetischem Öl befüllt. Bei Einbaulage V5 oder V6 bitten wir um Rücksprache. In Tabelle 1 ist die Schmiermenge und das empfohlene Schmiermittel angegeben. In Tabelle 2 sind die zulässigen Radial - und Axialbelastungen des Getriebes aufgeführt.

F Le réducteur de type **63A** est fourni lubrifié à vie avec de l'huile synthétique. Concernant les positions V5.V6, contactez notre service d'assistance technique. Voir tableau 1 concernant les huiles et les quantités conseillées. Les charges radiales et axiales applicables au réducteur sont précisées dans le tableau 2.

E El reductor tamaño **63A** se suministra, lubricado de por vida con aceite sintético. Para las posiciones V5 y V6 contactar con nuestro servicio técnico. Ver tabla 1, para cantidades y aceites recomendados. En la tabla 2, se encuentran las cargas radiales y axiales admitidas por el reductor.

LUBRICATION 63A Oil Quantity 0.40 Lt.

SHELL Omala S4 WE 320

ENI Telium VSF 320

For all details on lubrication and plugs check our website **tab. 1**
Per maggiori dettagli su lubrificazione e tappi olio vedi il nostro sito web

RADIAL AND AXIAL LOADS

Output shaft

Albero di uscita

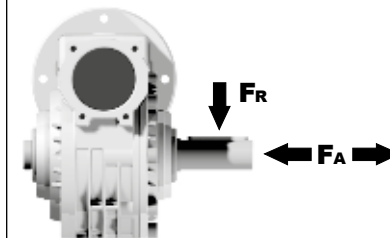

n_2 [min ⁻¹]	FA [N]	FR [N]
200	360	1800
150	400	2000
100	460	2300
75	500	2500
50	600	3000
25	700	3800
15	800	4000

Input shaft

albero in entrata

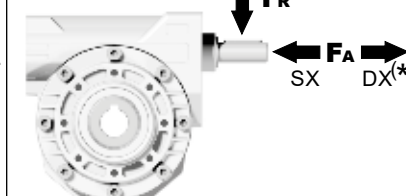

n_1 [min ⁻¹]	FA [N]	FR [N]
1400	90	450

***Strong axial loads in the DX direction are not allowed.**
Non sono consentiti forti carichi assiali con direzione DX

tab. 2

P63AFB... Basic wormbox
Riduttore base

Gearbox weight
peso riduttore **6.00 kg**

M. flanges	Kit code	øF	A
63B5	K063.4.041	140	99.5
71B5	K063.4.042	160	97.5
80/90B5	K063.4.043	200	99.5
71B14	K063.4.047	105	97.5
80B14	K063.4.046	120	99.5
90B14	K063.4.041	140	99.5

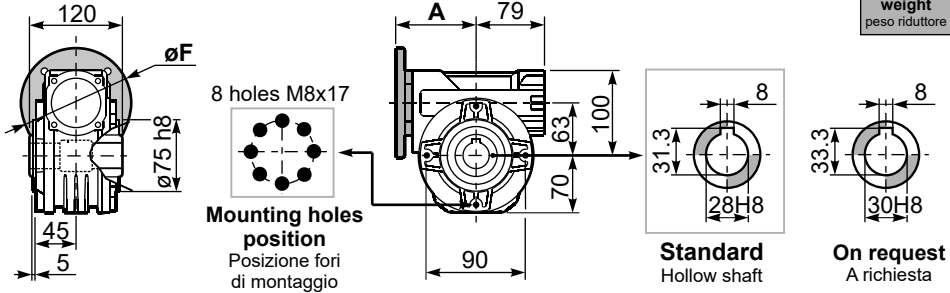

P63APA... Feet
Piedini

P63APB... Feet
Piedini

P63APV... Feet
Piedini

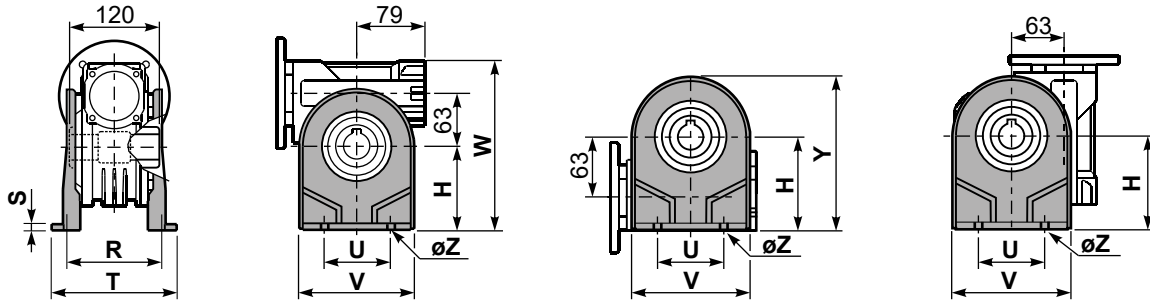

	H	R	S	T	U	V	Y	W	øZ	kit code
type B	115	115	12	142	120	156	185	215	ø11	K070.9.022
type S	-	-	-	-	-	-	-	-	-	-

P63AFC... Output flange
Flangia uscita

P63ABR... Reaction arm
Braccio di reazione

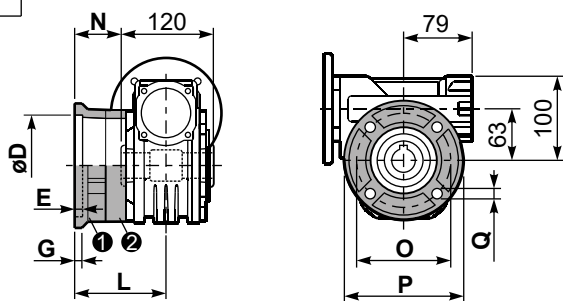

type B	øD	E	G	L	N	O	P	Q	kit code
FC	130 ^{+0.20} / _{+0.15}	7	13	85	25	165	200	13	① K070.9.010 ② -
FL	130 ^{+0.20} / _{+0.15}	7	13	111	51	165	200	13	① K070.9.010 ② K070.0.200
type S	øD	E	G	L	N	O	P	Q	kit code
F1	130 ^{+0.20} / _{+0.15}	7	13	111	51	165	200	13	① KS070.9.014 ② -
F2	115 ^{+0.20} / _{+0.15}	7	13	116	56	150	175	11	① KS063.9.013 ② -
F3	110 ^{+0.035} / ₀	5	13.5	84.5	24.5	130	160	11	① KS070.9.011 ② -

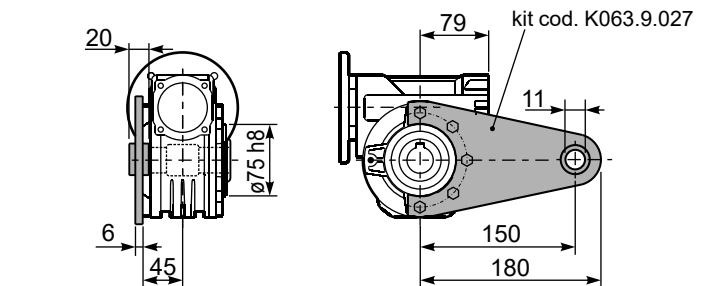

P63A...S... Single Shaft
Albero lento semplice

P63A...D... Double Shaft
Albero lento bisp.

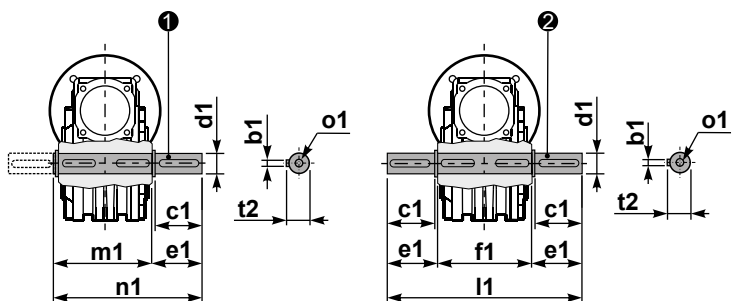

① kit cod. K070.5.028 type B

② kit cod. K070.5.029 type B

R63AFB... Input shaft
Albero in entrata

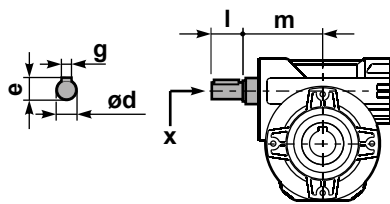

	ød	e	g	l	m	x	kit code
type B	18 h6	20.5	6	45	93	M6x16	① K063.5.006 PAM80 ② K063.5.007 PAM90
type S	19 h6	21.5	6	40	93	M8x20	① KS063.5.008 PAM80 ② KS063.5.009 PAM90

	b1	c1	d1	e1	f1	l1	m1	n1	t2	o1
type B	8	60	28 ^{-0.005} / _{-0.020}	63.5	120	247	127.5	191	31	M8x20
type S	-	-	-	-	-	-	-	-	-	-



QUICK SELECTION / Selezione veloce

input speed (n_1) = 1400 min⁻¹

Output Speed n_2 [min ⁻¹]	Ratio i	Motor power P_{1M} [kW]	Output torque M_{2M} [Nm]	Service factor f.s.	Nominal power P_{1R} [kW]	Nominal torque M_{2R} [Nm]	Available B5 motor flanges				Available B14 motor flanges			Dynamic efficiency RD	Tooth Module [mm]	Ratios code	
							-C	-D	-E	-F	-R	-T	-U				
							71	80	90	100 112	80	90	100 112				
200	7	4.0	168	1.5	6.1	257		B	B			B	B		88	4.23	01
140	10	4.0	218	1.3	5.2	284		B	B			B	B		80	4.2	02
100	14	3.0	223	1.4	4.1	305		B	B			B	B		78	4.5	03
70	20	2.2	237	1.2	2.7	294		B	B			B	B		79	3.4	04
64	22	2.2	258	1.1	2.5	294		B	B			B	B		78	3.1	05
50	28	2.2	315	1.1	2.4	347		B	B			B	B		75	4.7	06
37	38	1.5	276	1.2	1.8	336	B	B				B	B		71	3.5	07
30	46	1.5	320	1.0	1.5	326	B	B				B	B		68	3.1	08
27	52	1.1	258	1.1	1.2	289	B	B				B	B		66	2.7	09
21	67	1.1	327	0.9	0.97	289	B	B				B	B		65	2.1	10
18.9	74	0.75	220	1.2	0.91	268	B	B				B	B		58	1.9	11
14.6	96	0.55	191	1.3	0.70	242	B	B				B	B		53	1.5	12

A Motor Flanges Available
Flange Motore Disponibili

B Supplied with Reduction Bushing
Fornito con Bussola di Riduzione

B Available on Request without reduction bushing
Disponibile a Richiesta senza Bussola di Riduzione

C Motor Flange Holes Position
Posizione Fori Flangia Motore

EN Unit 085 is supplied with synthetic oil, providing "long life" lubrication. For mounting position V5-V6 please contact us. See table 1 for lubrication and recommended quantity. In table 2 please see possible radial loads and axial loads on the gearbox.

I Il riduttore tipo 085 viene fornito lubrificato a vita con olio sintetico. Per posizioni V5-V6 contattare il ns. servizio tecnico. Vedi tab.1 per oli e quantità consigliati. In tab.2 sono presenti i carichi radiali e assiali applicabili al riduttore.

D Für die Lebensdauerschmierung ist das Getriebe der Größe 085 mit synthetischem Öl befüllt. Bei Einbaulage V5 oder V6 bitten wir um Rücksprache. In Tabelle 1 ist die Schmiermenge und das empfohlene Schmiermittel angegeben. In Tabelle 2 sind die zulässigen Radial- und Axialbelastungen des Getriebes aufgeführt.

F Le réducteur de type 085 est fourni lubrifié à vie avec de l'huile synthétique. Concernant les positions V5.V6, contactez notre service d'assistance technique. Voir tableau 1 concernant les huiles et les quantités conseillées. Les charges radiales et axiales applicables au réducteur sont précisées dans le tableau 2.

E El reductor tamaño 085 se suministra, lubricado de por vida con aceite sintético. Para las posiciones V5 y V6 contactar con nuestro servicio técnico. Ver tabla 1, para cantidades y aceites recomendados. En la tabla 2, se encuentran las cargas radiales y axiales admitidas por el reductor.

LUBRICATION 085 Oil Quantity 1.20 Lt.

SHELL Omala S4 WE 320

ENI Telium VSF 320

For all details on lubrication and plugs check our website **tab. 1**
Per maggiori dettagli su lubrificazione e tappi olio vedi il nostro sito web

RADIAL AND AXIAL LOADS

Output shaft

Albero di uscita

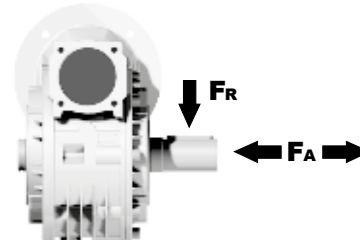

n_2 [min ⁻¹]	FA [N]	FR [N]
200	500	2500
150	580	2900
100	600	3000
75	700	3500
50	800	4000
25	1000	5000
15	1160	5800

Input shaft

albero in entrata

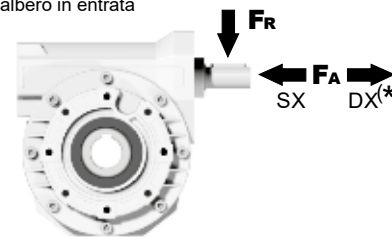

n_1 [min ⁻¹]	FA [N]	FR [N]
1400	130	650

*Strong axial loads in the DX direction are not allowed.
Non sono consentiti forti carichi assiali con direzione DX

tab. 2

P085FB... Basic wormbox
Riduttore base

Gearbox weight
peso riduttore **11.00 kg**

M. flanges	Kit code	øF	A
71B5	K023.4.041	160	116.5
80/90B5	K023.4.042	200	118.5
100/112B5	K023.4.043	250	127.5
80B14	K085.4.046	120	118.5
90B14	K085.4.045	140	118.5
100/112B14	K085.4.047	160	127.5

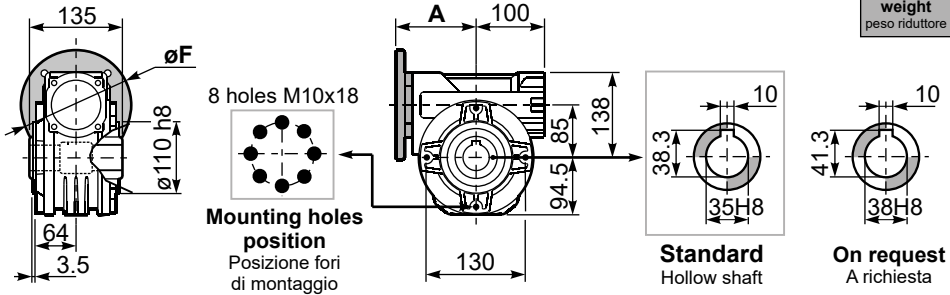

P085PA... Feet
Piedini

P085PB... Feet
Piedini

P085PV... Feet
Piedini

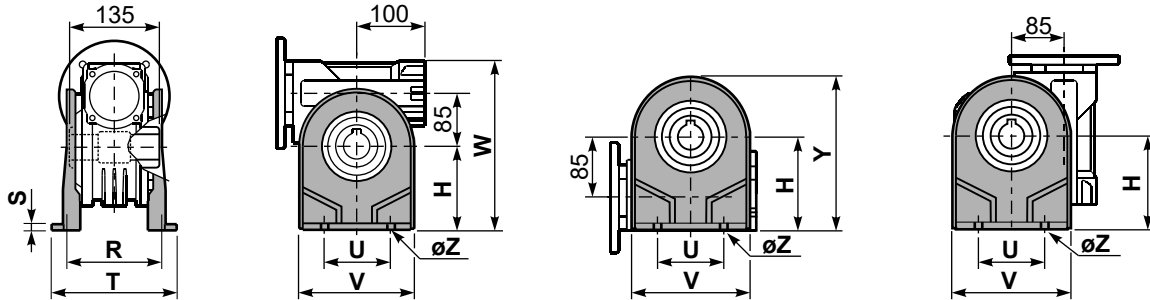

	H	R	S	T	U	V	Y	W	øZ	kit code
type B	142	145	5	182	140	180	236.5	280	ø10.5	K085.9.022
type S	-	-	-	-	-	-	-	-	-	-

P085FC... Output flange
Flangia uscita

P085BR... Reaction arm
Braccio di reazione

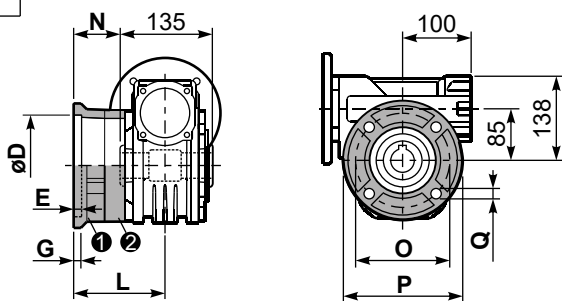

type B	øD	E	G	L	N	O	P	Q	kit code
FC	152 ^{+0.06} / _{+0.00}	5	16	108	40.5	176	205	13	① K085.9.010 ② -
FL	152 ^{+0.06} / _{+0.00}	5	16	148.5	81	176	205	13	① K085.9.010 ② K085.0.201
type S	øD	E	G	L	N	O	P	Q	kit code
F1	130 H7	5	13	117.5	50	165	200	11.5	① KS085.9.012 ② -
F2	152 ^{+0.06} / _{+0.00}	5	15	147.5	80	180	205	12.5	① KS085.9.013 ② -
F4	130 H7	5	13	106.5	39	165	200	13	① KS085.9.015 ② -

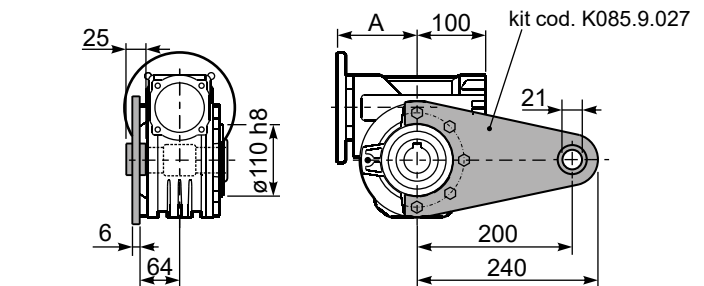

P085.....S... Single Shaft
Albero lento semplice

P085.....D... Double Shaft
Albero lento bisp.

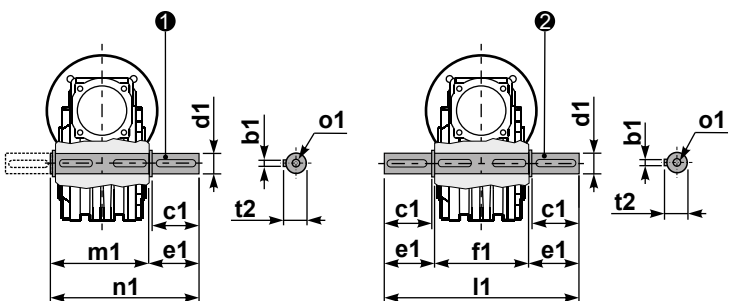

① kit cod. K085.5.028 type B ② kit cod. K085.5.029 type B

R085FB... Input shaft
Albero in entrata

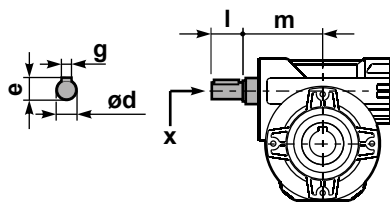

	ød	e	g	l	m	x	kit code
type B	25 h6	28	8	50	112	M8x20	① K085.5.007 PAM90 ② K085.5.008 PAM100
type S	24 h6	27	8	50	112	M8x20	① KS085.5.009 PAM90 ② KS085.5.011 PAM100

	b1	c1	d1	e1	f1	l1	m1	n1	t2	o1
type B	10	60	35 ^{-0.005} / _{-0.020}	73.5	135	282	141	214.5	38	M10x23
type S	-	-	-	-	-	-	-	-	-	-



QUICK SELECTION / Selezione veloce

input speed (n_1) = 1400 min⁻¹

Output Speed n_2 [min ⁻¹]	Ratio i	Motor power P_{1M} [kW]	Output torque M_{2M} [Nm]	Service factor f.s.	Nominal power P_{1R} [kW]	Nominal torque M_{2R} [Nm]	Available B5 motor flanges					Available B14 motor flanges				Dynamic efficiency RD	Tooth Module [mm]	Ratios code	
							-C	-D	-E	-F	-G	-R	-T	-U	-V				
							71	80	90	100 112	132	80	90	100 112	132				
200	7	7.5	315	1.5	11.5	483		B	B				B	B			88	5.5	01
140	10	7.5	440	1.2	9.0	525		B	B				B	B			86	5.4	02
88	16	5.5	492	1.1	6.0	536		B	B				B	B			82	5.3	03
70	20	4.0	447	1.2	4.9	546		B	B				B	B			82	4.5	04
61	23	3.0	377	1.4	4.1	515		B	B				B	B			80	3.9	05
47	30	3.0	467	1.4	4.2	651		B	B				B	B			76	5.6	06
37	38	3.0	583	1.1	3.3	641		B	B				B	B			75	4.7	07
31	45	2.2	493	1.2	2.7	599		B	B				B	B			73	4.0	08
26	53	2.2	557	1.1	2.5	620		B	B				B	B			70	3.5	09
22	64	1.5	452	1.2	1.8	536	B	B					B				69	2.9	10
16.7	84	1.1	410	1.2	1.3	494	B	B					B				65	2.2	11
14.1	99	1.1	446	1.1	1.2	483	B	B					B				60	1.9	12

A) Motor Flanges Available
Flange Motore Disponibili

B) Supplied with Reduction Bushing
Fornito con Bussola di Riduzione

B) Available on Request without reduction bushing
Disponibile a Richiesta senza Bussola di Riduzione

C) Motor Flange Holes Position
Posizione Fori Flangia Motore

EN Unit 110 is supplied without lubricant and equipped with a breather, level and drain plugs. User can add mineral oil keeping existing plugs. Should the user wish to fill it with synthetic oil, it is recommended to replace the existing plugs with a closed plug.
See table 1 for lubrication and recommended quantity.
In table 2 please see possible radial loads and axial loads on the gearbox.

I Il riduttore tipo 110 è fornito privo di lubrificazione con tappi di sfiato, livello e scarico olio. L'utente può immettere olio minerale mantenendo i tappi esistenti. Se immetterà olio sintetico, dovrà sostituire i tappi esistenti con altri tipo chiuso.
Tab.1 per oli e quantità consigliati.
Tab.2 carichi radiali e assiali applicabili al riduttore.

D Das Getriebe der Baugröße 110 wird ohne Schmiermittel geliefert. Es ist jedoch mit Einfüllschraube, Überdruckventil und Ablassschraube ausgerüstet. Das benötigte mineralische Öl kann über die Einfüllschraube eingefüllt werden. Sollte synthetisches Öl bevorzugt werden, so ist sind das eingebaute Überdruckventil durch eine geschlossenen Schraube zu ersetzen.
In Tabelle 1 ist die Schmiermenge und das empfohlene Schmiermittel angegeben
In Tabelle 2 sind die zulässigen Radial - und Axialbelastungen des Getriebes aufgeführt.

F Le réducteur de type 110 est fourni sans lubrification et avec un bouchon de remplissage, de niveau et d'évacuation de l'huile. L'utilisateur peut y verser de l'huile minérale en conservant les bouchons existants.
S'il y versera de l'huile synthétique, il devra substituer les bouchons existants avec d'autres bouchons de type fermé.
Voir tableau 1 concernant les huiles et les quantités conseillées.
Voir tableau 2 concernant les charges radiales et axiales applicables au réducteur.

E El reductor tamaño 110 se suministra sin lubricante, provisto de tapones de respiración, nivel y descarga de aceite. El usuario puede utilizar aceite mineral, manteniendo los tapones existentes. Si prefiere utilizar aceite sintético deberá sustituir los tapones existentes por tapones ciegos. La prerreducción se suministra con tapones ciegos, lubricado de por vida con aceite sintético. Ver tabla 1, para cantidades y aceites recomendados. En la tabla 2, se encuentran las cargas radiales y axiales admitidas por el reductor.

B3	B6	B7	B8	V5	V6
1.90 LT	1.35 LT	1.35 LT	2.00LT	2.00 LT	2.00LT
SHELL Omala S2 GX 460			ENI Blasias 460		

For all details on lubrication and plugs check our website [www.enigearboxes.com](#) **tab. 1**
Per maggiori dettagli su lubrificazione e tappi olio vedi il nostro sito web

RADIAL AND AXIAL LOADS

Output shaft
Albero di uscita

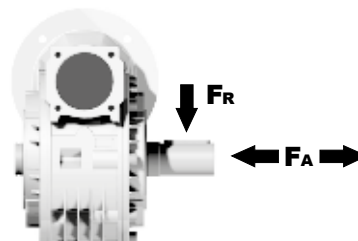

n_2 [min ⁻¹]	FA [N]	FR [N]
200	600	2900
150	700	3300
100	750	3600
75	800	4000
50	920	4600
25	1200	6000
15	1400	7000

Input shaft
albero in entrata

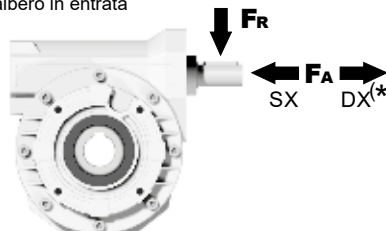

n_1 [min ⁻¹]	FA [N]	FR [N]
1400	228	1140

***Strong axial loads in the DX direction are not allowed.**
Non sono consentiti forti carichi assiali con direzione DX

tab. 2

P110FB... Basic wormbox
Riduttore base

Gearbox weight
peso riduttore **35.00 kg**

M. flanges	Kit code	øF	A
71B5	K023.4.041	160	136
80/90B5	K023.4.042	200	138
100/112B5	K023.4.043	250	147
132B5	-	300	187
80B14	K085.4.046	120	138
90B14	K085.4.045	140	138
100/112B14	K023.4.041	160	136
132B14	-	200	187

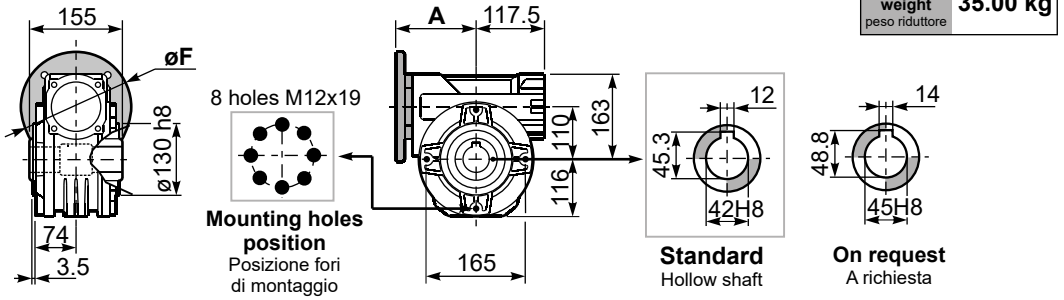

P110PA... Feet
Piedini

P110PB... Feet
Piedini

P110PV... Feet
Piedini

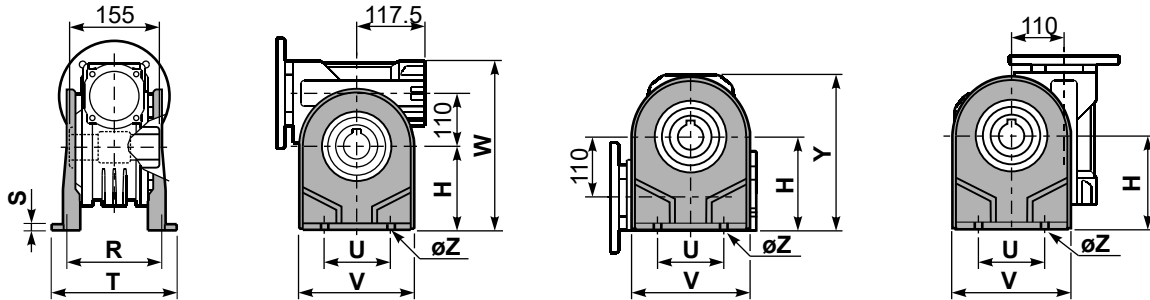

	H	R	S	T	U	V	Y	W	øZ	kit code
type B	170	180	8	224	200	240	286	333	ø13	K110.9.022
type S	-	-	-	-	-	-	-	-	-	-

P110FC... Output flange
Flangia uscita

P110BR... Reaction arm
Braccio di reazione

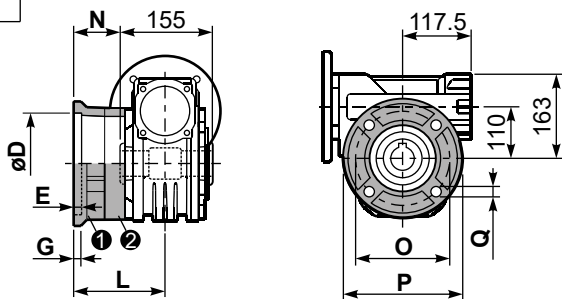

type B	øD	E	G	L	N	O	P	Q	kit code
FC	170 ^{+0.083} / _{-0.043}	11	16.5	131.5	54	230	270	13	① K110.9.010 ② -
FL	170 ^{+0.083} / _{-0.043}	11	16.5	179.5	102	230	270	13	① K110.9.011 ② -
type S	øD	E	G	L	N	O	P	Q	kit code
F1	180 ^{+0.040} / ₀	5	18	150	72.5	215	250	15	① KS110.9.014 ② -
F3	180 ^{+0.040} / ₀	5	18	130	52.5	215	250	15	① KS110.9.013 ② -

P110.....S... Single Shaft
Albero lento semplice

P110.....D... Double Shaft
Albero lento bisp.

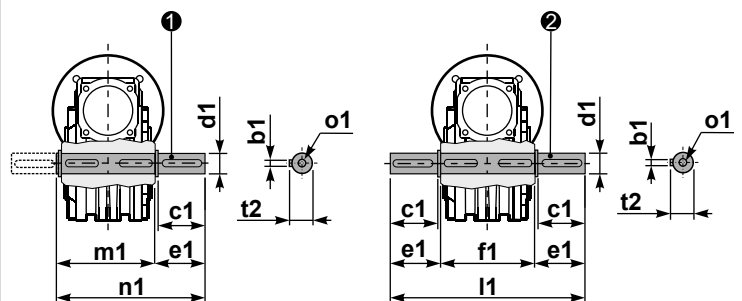

① kit cod. K110.5.028 type B

② kit cod. K110.5.029 type B

R110FB... Input shaft
Albero in entrata

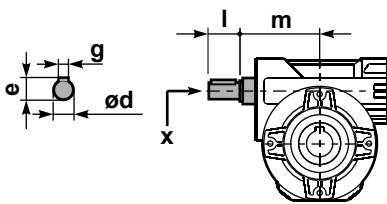

	ød	e	g	l	m	x	kit code
type B	25 h6	28	8	50	131.5	M8x20	① K085.5.007 PAM90 ② K085.5.008 PAM100
type S	24 h6	27	8	50	131.5	M8x20	① KS085.5.009 PAM90 ② KS085.5.011 PAM100

	b1	c1	d1	e1	f1	l1	m1	n1	t2	o1
type B	12	75	42 ^{-0.005} / _{-0.020}	96.5	155	348	163.5	260	45	M12x32
type S	-	-	-	-	-	-	-	-	-	-

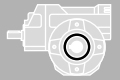

QUICK SELECTION / Selezione veloce

input speed (n_1) = 1400 min⁻¹

Output Speed n_2 [min ⁻¹]	Ratio i	Motor power P_{1M} [kW]	Output torque M_{2M} [Nm]	Service factor f.s.	Nominal power P_{1R} [kW]	Nominal torque M_{2R} [Nm]	Available B5 motor flanges			Available B14 motor flanges		Dynamic efficiency RD	Tooth Module [mm]	Ratios code
							-A	-B	-C	-P	-Q			
							56	63	71	63	71			
47	30.1	0.25	38	1.4	0.36	55				C		74	2.2	01
33	43.0	0.25	53	1.0	0.26	55				C		72	2.2	02
23	60.2	0.25	62	0.9	0.22	55				C		60	2.4	03
15.5	90.3	0.12	42	1.3	0.16	55				C		57	1.6	04
11.6	120	0.12	52	1.1	0.13	55				C		53	2.5	05
8.8	159	0.12	64	0.9	0.10	55				C		49	1.8	06
7.1	198	0.12*	55	<0.8	0.09	55				C		47	1.5	07
5.4	258	0.12*	55	<0.8	0.07	55				C		45	1.2	08
4.7	301	0.12*	39	<0.8	0.05	39				C		40	1.0	09
3.2	439	0.12*	39	<0.8	0.04	39				C		36	0.72	10

A) Motor Flanges Available
Flange Motore Disponibili

B) Supplied with Reduction Bushing
Fornito con Bussola di Riduzione

B) Available on Request without reduction bushing
Disponibile a Richiesta senza Bussola di Riduzione

C) Motor Flange Holes Position
Posizione Fori Flangia Motore

* Power higher than the maximum one which can be supported by the gearbox. Select according to the torque M_{2R}
Potenza superiore a quella massima sopportabile dal riduttore. Selezionare in base al momento torcente M_{2R}

EN Unit **P45** is supplied with synthetic oil, providing "long life" lubrication. For mounting position V5-V6 please contact us. See table 1 for lubrication and recommended quantity. In table 2 please see possible radial loads and axial loads on the gearbox.

I Il riduttore tipo **P45** viene fornito lubrificato a vita con olio sintetico. Per posizioni V5-V6 contattare il ns. servizio tecnico. Vedi tab.1 per oli e quantità consigliati. In tab.2 sono presenti i carichi radiali e assiali applicabili al riduttore.

D Für die Lebensdauerschmierung ist das Getriebe der Größe **P45** mit synthetischem Öl befüllt. Bei Einbaulage V5 oder V6 bitten wir um Rücksprache. In Tabelle 1 ist die Schmiermenge und das empfohlene Schmiermittel angegeben. In Tabelle 2 sind die zulässigen Radial- und Axialbelastungen des Getriebes aufgeführt.

F Le réducteur de type **P45** est fourni lubrifié à vie avec de l'huile synthétique. Concernant les positions V5.V6, contactez notre service d'assistance technique. Voir tableau 1 concernant les huiles et les quantités conseillées. Les charges radiales et axiales applicables au réducteur sont précisées dans le tableau 2.

E El reductor tamaño **P45** se suministra, lubricado de por vida con aceite sintético. Para las posiciones V5 y V6 contactar con nuestro servicio técnico. Ver tabla 1, para cantidades y aceites recomendados. En la tabla 2, se encuentran las cargas radiales y axiales admitidas por el reductor.

LUBRICATION P45 Oil Common lubrication 0.17 l (A + B).

SHELL Omala S4 WE 320	ENI Telium VSF 320
-----------------------	--------------------

For all details on lubrication and plugs check our website tab. 1
Per maggiori dettagli su lubrificazione e tappi olio vedi il nostro sito web

RADIAL AND AXIAL LOADS

Output shaft
Albero di uscita

n_2 [min ⁻¹]	FA [N]	FR [N]
75	240	1200
50	260	1400
25	300	1800
15-6	400	2000

Input shaft
albero in entrata

n_1 [min ⁻¹]	FA [N]	FR [N]
1400	44	220

*Strong axial loads in the DX direction are not allowed.
Non sono consentiti forti carichi assiali con direzione DX

tab. 2

PP45FB... Basic wormbox
Riduttore base

Gearbox weight
peso riduttore **3.20 kg**

M. flanges	Kit code	øF	A
56B5	K050.4.046	120	137.5
63B5	K050.4.041	138	139.5
71B5	K050.4.042	160	137
63B14	K050.4.047	90	139.5
71B14	K050.4.045	105	137

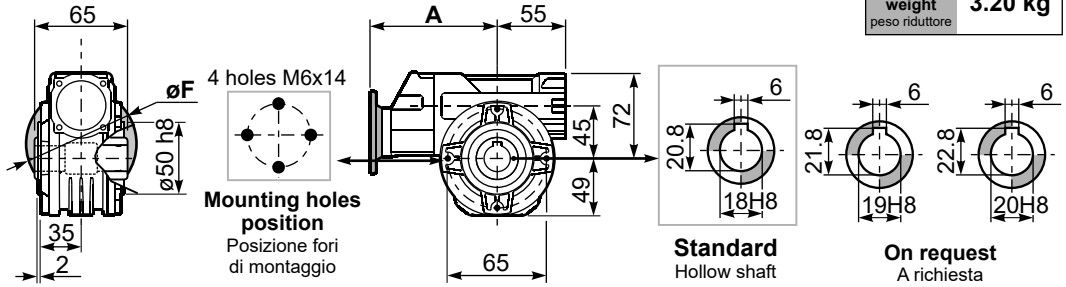

PP45PA... Feet
Piedini

PP45PB... Feet
Piedini

PP45PV... Feet
Piedini

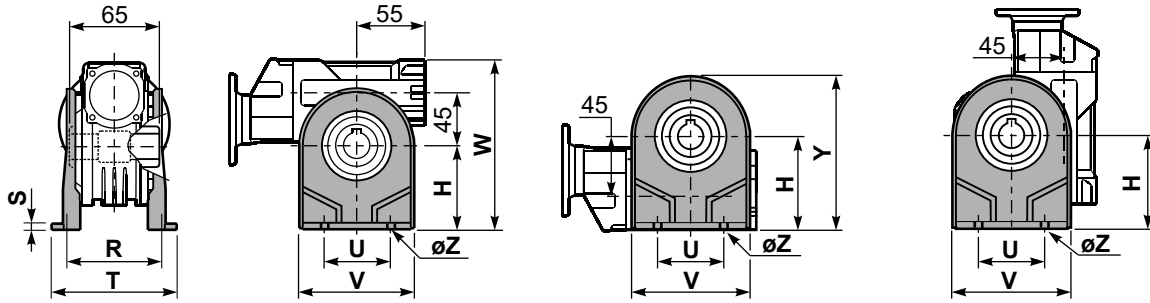

	H	R	S	T	U	V	Y	W	øZ	kit code
type B	72	81	3	100	52	98	121	144	ø10.5	K045.9.022
type S	71	84	8	100	70	90	120	143	ø8	KS045.9.023

PP45FC... Output flange
Flangia uscita

PP45BR... Reaction arm
Braccio di reazione

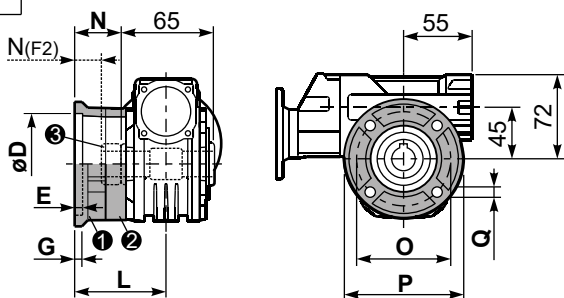

type B	øD	E	G	L	N	O	P	Q	kit code
FC	60 ^{+0.15} / _{+0.05}	9	9	60.5	28	87	110	8.5	① K045.9.010 ② -
FL	60 ^{+0.15} / _{+0.05}	9	9	90.5	58	87	110	8.5	① K045.9.010 ② K045.0.200

type S	øD	E	G	L	N	O	P	Q	kit code
F1	95 ^{+0.20} / _{+0.15}	4	11	73.5	41	115	140	9	① KS045.9.013 ② -
F2	60 ^{+0.15} / _{+0.05}	9	9	60.5	19	87	110	8.5	① KS045.9.010 ② S045.0.204
F3	80 ^{+0.03} / _{+0.00}	3	8	51.5	19	100	120	9	① KS045.9.014 ② -

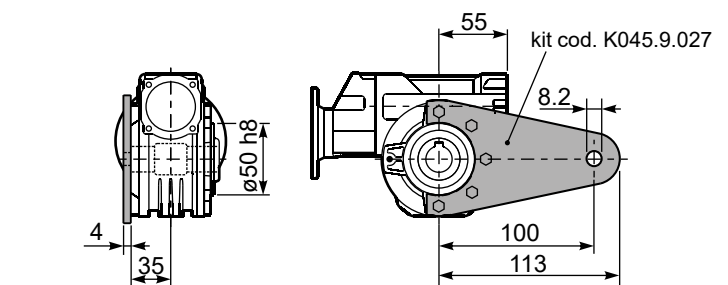

PP45....S... Single Shaft
Albero lento semplice

PP45....D... Double Shaft
Albero lento bisp.

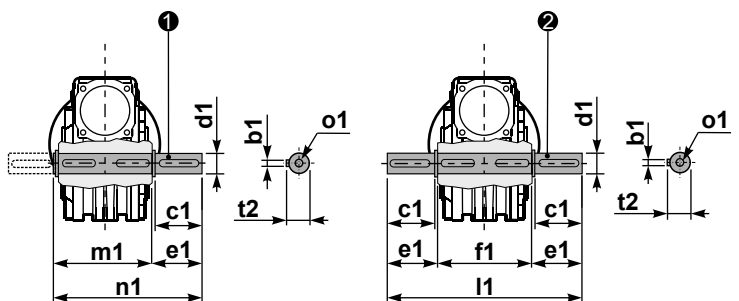

① kit cod. K045.5.028 type B
kit cod. KS045.5.030 type S

② kit cod. K045.5.029 type B

RP45FB... Input shaft
Albero in entrata

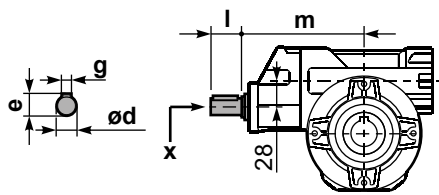

	ød	e	g	l	m	x
type B	14 h6	16	5	25	131	M5x13
type S	-	-	-	-	-	-

	b1	c1	d1	e1	f1	l1	m1	n1	t2	o1
type B	6	32	18 ^{-0.005} / _{-0.020}	43	65	151	70	113	20.5	M6x18
type S	6	40	19 ^{-0.005} / _{-0.020}	58.8	-	-	70	128.5	21.5	M8x20

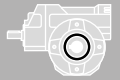

QUICK SELECTION / Selezione veloce

input speed (n_1) = 1400 min⁻¹

Output Speed n_2 [min ⁻¹]	Ratio i	Motor power P_{1M} [kW]	Output torque M_{2M} [Nm]	Service factor f.s.	Nominal power P_{1R} [kW]	Nominal torque M_{2R} [Nm]	Available B5 motor flanges			Available B14 motor flanges		Dynamic efficiency RD	Tooth Module [mm]	Ratios code
							-A	-B	-C	-P	-Q			
							56	63	71	63	71			
47	30.1	0.37	58	1.3	0.49	77				C		76	2.5	01
33	43.0	0.25	55	1.4	0.35	77				C		75	2.4	02
23	60.2	0.25	71	1.1	0.27	77				C		69	2.6	03
18.1	77.4	0.25	81	1.1	0.27	88				C		61	2.0	04
12.5	112	0.18	84	1.1	0.19	88				C		61	2.7	05
9.0	155	0.12	71	1.2	0.15	88				C		56	2.1	06
7.6	185	0.12	74	1.0	0.12	77				C		49	1.8	07
5.4	258	0.12*	77	<0.8	0.09	77				C		47	1.3	08
4.8	292	0.12*	66	<0.8	0.08	66				C		44	1.2	09
4.1	344	0.12*	44	<0.8	0.05	44				C		40	1.0	10
3.3	430	0.12*	44	<0.8	0.04	44				C		36	0.8	11

A) Motor Flanges Available
Flange Motore Disponibili

B) Supplied with Reduction Bushing
Fornito con Bussola di Riduzione

B) Available on Request without reduction bushing
Disponibile a Richiesta senza Bussola di Riduzione

C) Motor Flange Holes Position
Posizione Fori Flangia Motore

* Power higher than the maximum one which can be supported by the gearbox. Select according to the torque M_{2R}
Potenza superiore a quella massima sopportabile dal riduttore. Selezionare in base al momento torcente M_{2R}

EN Unit **P50** is supplied with synthetic oil, providing "long life" lubrication. For mounting position V5-V6 please contact us. See table 1 for lubrication and recommended quantity. In table 2 please see possible radial loads and axial loads on the gearbox.

I Il riduttore tipo **P50** viene fornito lubrificato a vita con olio sintetico. Per posizioni V5-V6 contattare il ns. servizio tecnico. Vedi tab.1 per oli e quantità consigliati. In tab.2 sono presenti i carichi radiali e assiali applicabili al riduttore.

D Für die Lebensdauerschmierung ist das Getriebe der Größe **P50** mit synthetischem Öl befüllt. Bei Einbaulage V5 oder V6 bitten wir um Rücksprache. In Tabelle 1 ist die Schmiermenge und das empfohlene Schmiermittel angegeben. In Tabelle 2 sind die zulässigen Radial - und Axialbelastungen des Getriebes aufgeführt.

F Le réducteur de type **P50** est fourni lubrifié à vie avec de l'huile synthétique. Concernant les positions V5.V6, contactez notre service d'assistance technique. Voir tableau 1 concernant les huiles et les quantités conseillées. Les charges radiales et axiales applicables au réducteur sont précisées dans le tableau 2.

E El reductor tamaño **P50** se suministra, lubricado de por vida con aceite sintético. Para las posiciones V5 y V6 contactar con nuestro servicio técnico. Ver tabla 1, para cantidades y aceites recomendados. En la tabla 2, se encuentran las cargas radiales y axiales admitidas por el reductor.

LUBRICATION P50 Oil
Common lubrication 0.26 l (A + B).



SHELL Omala S4 WE 320	ENI Telium VSF 320
------------------------------	---------------------------

For all details on lubrication and plugs check our website
Per maggiori dettagli su lubrificazione e tappi olio vedi il nostro sito web

tab. 1

RADIAL AND AXIAL LOADS

Output shaft
Albero di uscita

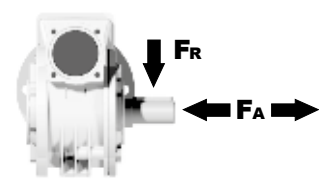

n_2 [min ⁻¹]	FA [N]	FR [N]
75	340	1700
50	380	1900
25	480	2500
15-6	560	2800

Input shaft
albero in entrata

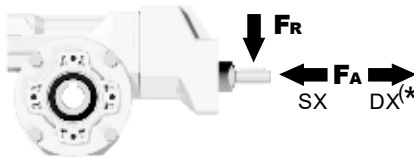

n_1 [min ⁻¹]	FA [N]	FR [N]
1400	44	220

*Strong axial loads in the DX direction are not allowed.
Non sono consentiti forti carichi assiali con direzione DX

tab. 2

PP50FB... Basic wormbox
Riduttore base

Gearbox weight
peso riduttore **3.80 kg**

M. flanges	Kit code	øF	A
56B5	K050.4.046	120	142
63B5	K050.4.041	138	144
71B5	K050.4.042	160	141.5
63B14	K050.4.047	90	144
71B14	K050.4.045	105	141.5

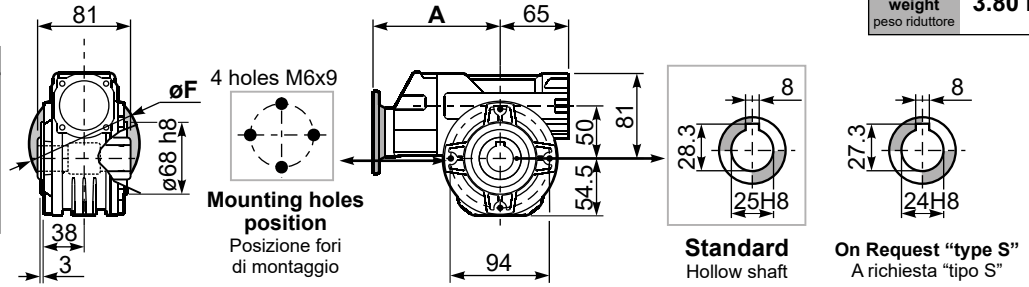

PP50PA... Feet
Piedini

PP50PB... Feet
Piedini

PP50PV... Feet
Piedini

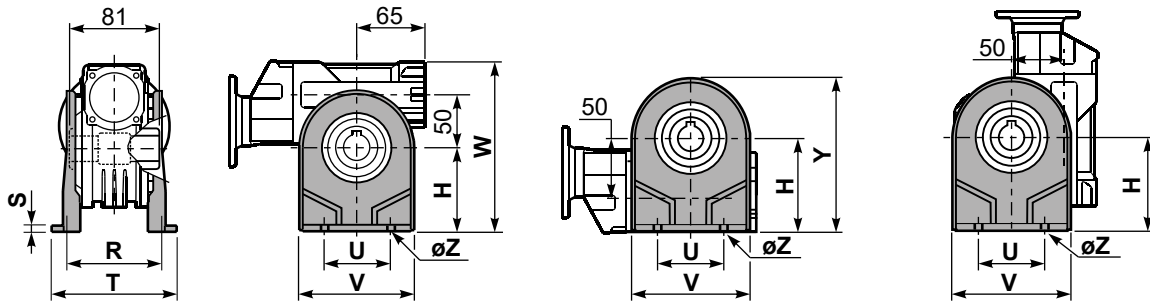

	H	R	S	T	U	V	Y	W	øZ	kit code
type B	82	98.5	3.5	123	63	113	138.5	163	ø10.5	K050.9.022
type S	85	96	10	114	85	110	139.5	166	ø10	KS050.9.023

PP50FC... Output flange
Flangia uscita

PP50BR... Reaction arm
Braccio di reazione

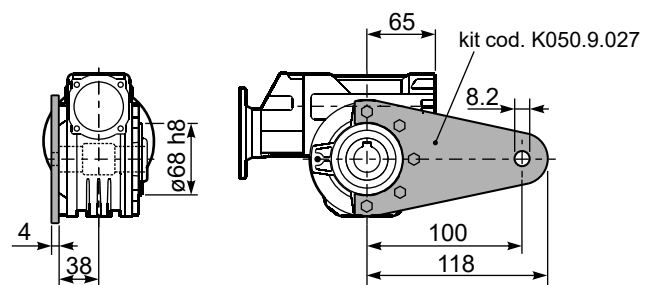
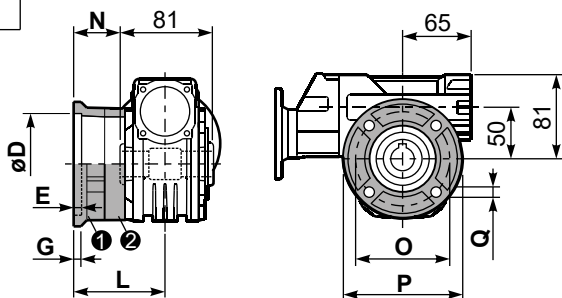

type B	øD	E	G	L	N	O	P	Q	kit code
FC	70 ^{+0.20} / _{+0.15}	9	12	85	44.5	90	123	10.5	① K050.9.010 ② -
FL	70 ^{+0.20} / _{+0.15}	9	12	114.5	74	90	123	10.5	① K050.9.010 ② K050.0.200

type S	øD	E	G	L	N	O	P	Q	kit code
F1	110 ^{+0.20} / _{+0.15}	4	11	83.5	43	130	160	10	① KS050.9.012 ② -
F2	70 ^{+0.20} / _{+0.15}	9	12	76.5	36	90	123	10.5	① KS050.9.014 ② -
F3	95 ^{+0.035} / ₀	4	10	66.5	26	115	140	10	① KS050.9.013 ② -

PP50....S... Single Shaft
Albero lento semplice

PP50....D... Double Shaft
Albero lento bisp.

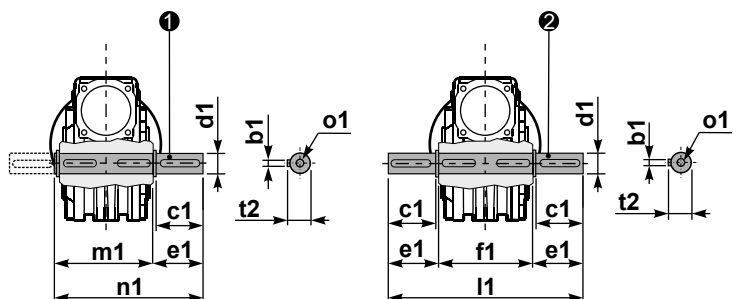

① kit cod. K050.5.028 type B
kit cod. KS050.5.030 type S

② kit cod. K050.5.029 type B

RP50FB... Input shaft
Albero in entrata

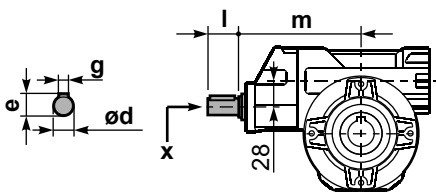

	ød	e	g	l	m	x
type B	14 h6	16	5	25	135.5	M5x13
type S	-	-	-	-	-	-

	b1	c1	d1	e1	f1	l1	m1	n1	t2	o1
type B	8	52	25 ^{-0.005} / _{-0.020}	59.5	81	200	86.5	146	28	M8x20
type S	8	50	24 ^{-0.005} / _{-0.020}	68.8	-	-	86.5	155	27	M8x20

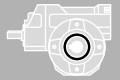

QUICK SELECTION / Selezione veloce

input speed (n_1) = 1400 min⁻¹

	Output Speed n_2 [min ⁻¹]	Ratio i	Motor power P_{1M} [kW]	Output torque M_{2M} [Nm]	Service factor f.s.	Nominal power P_{1R} [kW]	Nominal torque M_{2R} [Nm]	Available B5 motor flanges				Available B14 motor flanges				Dynamic efficiency RD	Tooth Module [mm]	 Ratios code
								-B	-C	-D	-E	-P	-Q	-R	-T			
								63	71	80	90	63	71	80	90			
IEC 90 - 80 - 71	47	29.9	0.75	113	1.5	1.1	165						C	C		74	2.6	01
	37	37.7	0.75	141	1.2	0.88	165						C	C		73	2.0	02
	30	47.1	0.75	169	1.1	0.83	187						C	C		70	3.2	03
	25	56.6	0.55	136	1.4	0.76	187						C	C		64	2.7	04
	19.8	70.7	0.55	164	1.1	0.63	187						C	C		62	2.1	05
	15.9	87.8	0.37	162	1.2	0.43	187						C	C		73	2.6	06
	12.6	111.0	0.37	199	0.9	0.35	187						C	C		71	2.0	07
IEC 71 - 63	10.1	139	0.37	234	0.8	0.30	187						C			67	3.2	08
	8.4	166	0.25	173	1.1	0.27	187						C			61	2.7	09
	6.7	208	0.18	151	1.1	0.20	165						C			59	2.1	10
	4.5	310	0.12	129	1.3	0.15	165						C			51	1.5	11
	3.8	370	0.12	145	1.1	0.14	165						C			48	1.3	12
	3.2	434	0.12	149	0.9	0.11	138						C			42	1.1	13

A Motor Flanges Available
Flange Motore Disponibili

B Supplied with Reduction Bushing
Fornito con Bussola di Riduzione

B Available on Request without reduction bushing
Disponibile a Richiesta senza Bussola di Riduzione

C Motor Flange Holes Position
Posizione Fori Flangia Motore

EN Unit **P63** is supplied with synthetic oil, providing "long life" lubrication. For mounting position V5-V6 please contact us. See table 1 for lubrication and recommended quantity. In table 2 please see possible radial loads and axial loads on the gearbox.

I Il riduttore tipo **P63** viene fornito lubrificato a vita con olio sintetico. Per posizioni V5-V6 contattare il ns. servizio tecnico. Vedi tab.1 per oli e quantità consigliati. In tab.2 sono presenti i carichi radiali e assiali applicabili al riduttore.

D Für die Lebensdauerschmierung ist das Getriebe der Größe **P63** mit synthetischem Öl befüllt. Bei Einbaulage V5 oder V6 bitten wir um Rücksprache. In Tabelle 1 ist die Schmiermenge und das empfohlene Schmiermittel angegeben. In Tabelle 2 sind die zulässigen Radial- und Axialbelastungen des Getriebes aufgeführt.

F Le réducteur de type **P63** est fourni lubrifié à vie avec de l'huile synthétique. Concernant les positions V5.V6, contactez notre service d'assistance technique. Voir tableau 1 concernant les huiles et les quantités conseillées. Les charges radiales et axiales applicables au réducteur sont précisées dans le tableau 2.

E El reductor tamaño **P63** se suministra, lubricado de por vida con aceite sintético. Para las posiciones V5 y V6 contactar con nuestro servicio técnico. Ver tabla 1, para cantidades y aceites recomendados. En la tabla 2, se encuentran las cargas radiales y axiales admitidas por el reductor.

LUBRICATION P63 Oil

For B3-V5-V6 separate lubrication for A (0.40 l) B (0.08 l) , for B6-B7-B8 common lubrication 0.38 l (A + B).



SHELL Omala S4 WE 320

ENI Telium VSF 320

For all details on lubrication and plugs check our website **tab. 1**
Per maggiori dettagli su lubrificazione e tappi olio vedi il nostro sito web

RADIAL AND AXIAL LOADS

Output shaft

Albero di uscita

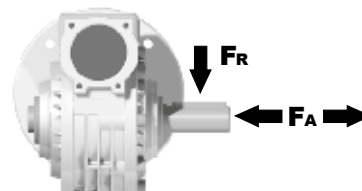

n_2 [min ⁻¹]	FA [N]	FR [N]
75	500	2500
50	600	3000
25	700	3800
15-6	800	4000

Input shaft

albero in entrata

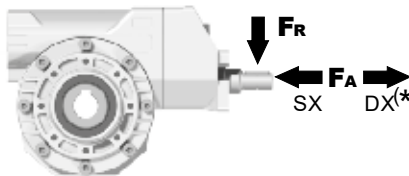

n_1 [min ⁻¹]	FA [N]	FR [N]
1400	61	305

*Strong axial loads in the DX direction are not allowed.
Non sono consentiti forti carichi assiali con direzione DX

tab. 2

PP63**FB**... Basic wormbox
Riduttore base

Gearbox weight	29.9+111	139+434
peso riduttore	7.30 Kg	7.80 Kg

M.flange	Kit code	øF	A
71B5	K063.4.042	160	176.5
80/90B5	K063.4.043	200	178.5
71B14	K063.4.047	105	176.5
80B14	K063.4.046	120	178.5
90B14	K063.4.041	140	178.5
<hr/>			
139+434	63B5	K050.4.041	138 162.5
	71B5	K050.4.042	160 160
	63B14	K050.4.047	90 162.5
	71B14	K050.4.045	105 160

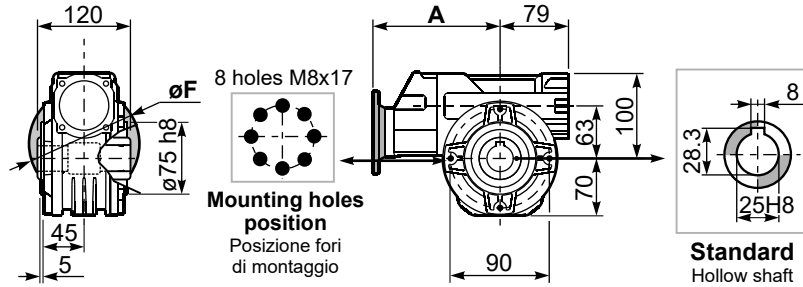

PP63**PA**... Feet
Piedini

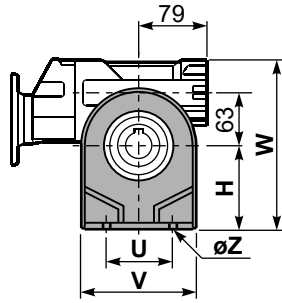
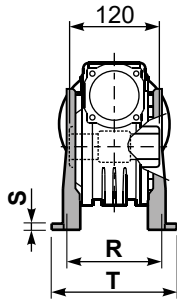

PP63**PB**... Feet
Piedini

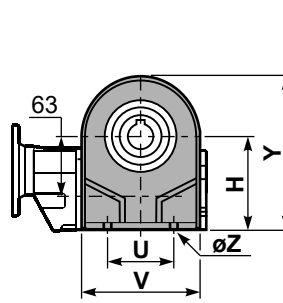

PP63**PV**... Feet
Piedini

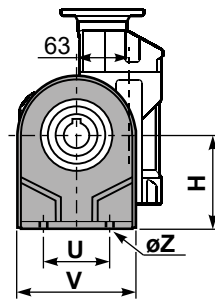

	H	R	S	T	U	V	Y	W	øZ	kit code
type B	100	111	4	144	95	133	170	200	ø10.5	K063.9.022
type S	-	-	-	-	-	-	-	-	-	-

PP63**FC**... Output flange
Flangia uscita

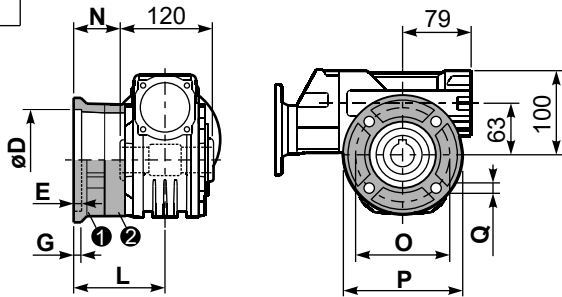

type B	øD	E	G	L	N	O	P	Q	kit code
FC	115 ^{+0.20} / _{+0.15}	7	13	86	26	150	175	11	① K063.9.010 ② -
FL	115 ^{+0.20} / _{+0.15}	7	13	116	56	150	175	11	① K063.9.010 ② K063.0.200
<hr/>									
type S	øD	E	G	L	N	O	P	Q	kit code
F1	130 ^{+0.20} / _{+0.15}	7	13	102	42	165	200	13	① KS070.9.013 ② -
F2	115 ^{+0.20} / _{+0.15}	7	13	116	56	150	175	11	① KS063.9.013 ② -
F3	110 ^{+0.035} / ₀	5	11	82	22	130	160	10	① KS063.9.011 ② -

PP63**BR**... Reaction arm
Braccio di reazione

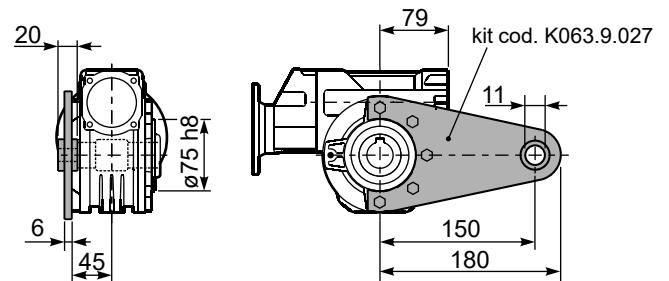

PP63.....**S**... Single Shaft
Albero lento semplice

PP63.....**D**... Double Shaft
Albero lento bisp.

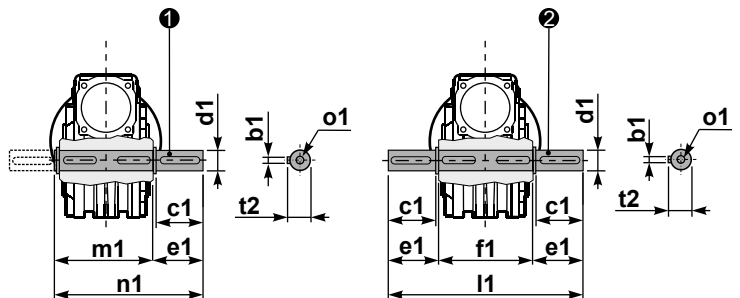

① kit cod. K063.5.028 type B

② kit cod. K063.5.029 type B

RP63**FB**... Input shaft
Albero in entrata

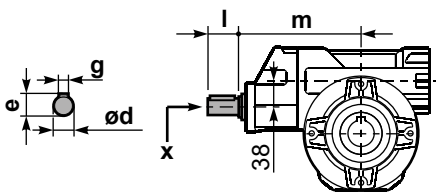

	ød	e	g	l	m	x
29.9+111	19 h6	21.5	6	35	169.4	M6x16
139+434	14 h6	16	5	25	154.2	M5x13

	b1	c1	d1	e1	f1	l1	m1	n1	t2	o1
type B	8	60	25 ^{-0.005} / _{-0.020}	63.2	120	246.4	126.8	190	28	M8x20
type S	-	-	-	-	-	-	-	-	-	-



QUICK SELECTION / Selezione veloce

input speed (n₁) = 1400 min⁻¹

	Output Speed n ₂ [min ⁻¹]	Ratio i	Motor power P _{IM} [kW]	Output torque M _{2M} [Nm]	Service factor f.s.	Nominal power P _{1R} [kW]	Nominal torque M _{2R} [Nm]	Available B5 motor flanges				Available B14 motor flanges				Dynamic efficiency RD	Tooth Module [mm]	Ratios code
								-B	-C	-D	-E	-P	-Q	-R	-T			
								63	71	80	90	63	71	80	90			
IEC 90 - 80 - 71	47	29.9	0.75	113	1.6	1.20	182					C	C		74	2.6	01	
	37	37.7	0.75	141	1.3	0.97	182					C	C		73	2.0	02	
	30	47.1	0.75	169	1.2	0.91	206					C	C		70	3.2	03	
	25	56.6	0.75	185	1.1	0.83	206					C	C		64	2.7	04	
	19.8	70.7	0.55	162	1.3	0.70	206					C	C		61	2.1	05	
	15.9	87.8	0.37	160	1.4	0.51	218					C	C		72	2.6	06	
	12.6	111.0	0.37	196	1.1	0.41	218					C	C		70	2.0	07	
IEC 71 - 63	10.1	139	0.37	231	0.9	0.35	218					C			66	3.2	08	
	8.4	166	0.25	170	1.3	0.32	218					C			60	2.7	09	
	6.7	208	0.25	195	1.0	0.25	194					C			55	2.1	10	
	4.5	310	0.18	194	1.0	0.18	194					C			51	1.5	11	
	3.8	370	0.18	213	0.9	0.16	194					C			47	1.3	12	
	3.2	434	0.18*	143	<0.8	0.11	143					C			42	1.1	13	

A Motor Flanges Available
Flange Motore Disponibili

B Supplied with Reduction Bushing
Fornito con Bussola di Riduzione

B Available on Request without reduction bushing
Disponibile a Richiesta senza Bussola di Riduzione

C Motor Flange Holes Position
Posizione Fori Flangia Motore

* Power higher than the maximum one which can be supported by the gearbox. Select according to the torque M_{2R}
Potenza superiore a quella massima sopportabile dal riduttore. Selezionare in base al momento torcente M_{2R}

EN Unit P6A is supplied with synthetic oil, providing "long life" lubrication. For mounting position V5-V6 please contact us. See table 1 for lubrication and recommended quantity. In table 2 please see possible radial loads and axial loads on the gearbox.

I Il riduttore tipo P6A viene fornito lubrificato a vita con olio sintetico. Per posizioni V5-V6 contattare il ns. servizio tecnico. Vedi tab.1 per oli e quantità consigliati. In tab.2 sono presenti i carichi radiali e assiali applicabili al riduttore.

D Für die Lebensdauerschmierung ist das Getriebe der Größe P6A mit synthetischem Öl befüllt. Bei Einbaulage V5 oder V6 bitten wir um Rücksprache. In Tabelle 1 ist die Schmiermenge und das empfohlene Schmiermittel angegeben. In Tabelle 2 sind die zulässigen Radial- und Axialbelastungen des Getriebes aufgeführt.

F Le réducteur de type P6A est fourni lubrifié à vie avec de l'huile synthétique. Concernant les positions V5.V6, contactez notre service d'assistance technique. Voir tableau 1 concernant les huiles et les quantités conseillées. Les charges radiales et axiales applicables au réducteur sont précisées dans le tableau 2.

E El reductor tamaño P6A se suministra, lubricado de por vida con aceite sintético. Para las posiciones V5 y V6 contactar con nuestro servicio técnico. Ver tabla 1, para cantidades y aceites recomendados. En la tabla 2, se encuentran las cargas radiales y axiales admitidas por el reductor.

LUBRICATION P6A Oil

For B3-V5-V6 separate lubrication for A (0.40 l) B (0.08 l) , for B6-B7-B8 common lubrication 0.38 l (A + B).

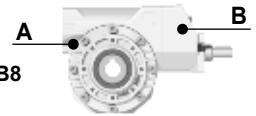

SHELL Omala S4 WE 320

ENI Telium VSF 320

For all details on lubrication and plugs check our website **tab. 1**
Per maggiori dettagli su lubrificazione e tappi olio vedi il nostro sito web

RADIAL AND AXIAL LOADS

Output shaft

Albero di uscita

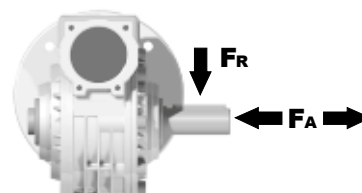

n ₂ [min ⁻¹]	FA [N]	FR [N]
75	500	2500
50	600	3000
25	700	3800
15-6	800	4000

Input shaft

albero in entrata

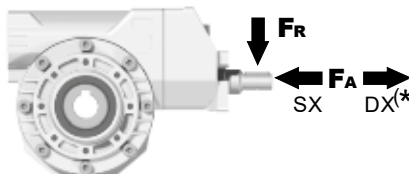

n ₁ [min ⁻¹]	FA [N]	FR [N]
1400	61	305

*Strong axial loads in the DX direction are not allowed.
Non sono consentiti forti carichi assiali con direzione DX

tab. 2

PP6A^{FB}... Basic wormbox
Riduttore base

Gearbox weight peso riduttore	29.9+111	139+434
	7.30 Kg	7.80 Kg

M.flange	Kit code	øF	A
71B5	K063.4.042	160	176.5
80/90B5	K063.4.043	200	178.5
71B14	K063.4.047	105	176.5
80B14	K063.4.046	120	178.5
90B14	K063.4.041	140	178.5
<hr/>			
139+434			
63B5	K050.4.041	138	162.5
71B5	K050.4.042	160	160
63B14	K050.4.047	90	162.5
71B14	K050.4.045	105	160

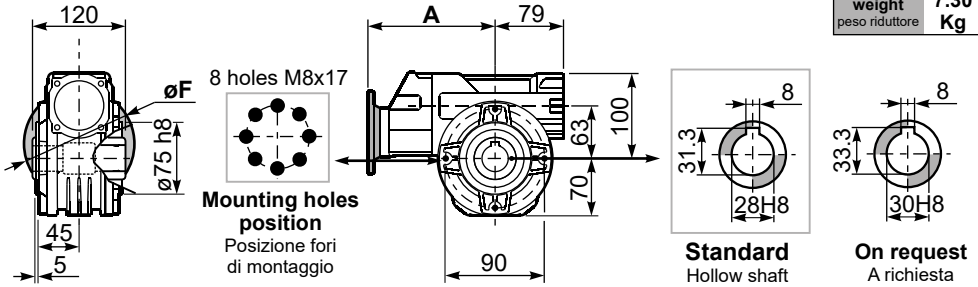

PP6A^{PA}... Feet
Piedini

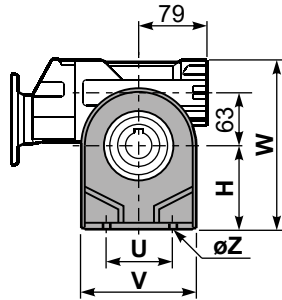
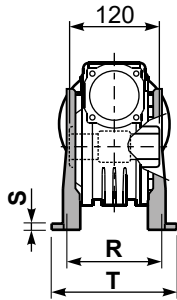

PP6A^{PB}... Feet
Piedini

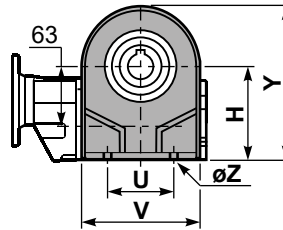

PP6A^{PV}... Feet
Piedini

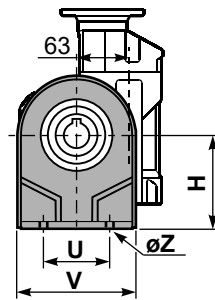

	H	R	S	T	U	V	Y	W	øZ	kit code
type B	115	115	12	142	120	156	185	215	ø11	K070.9.022
type S	-	-	-	-	-	-	-	-	-	-

PP6A^{FC}... Output flange
Flangia uscita

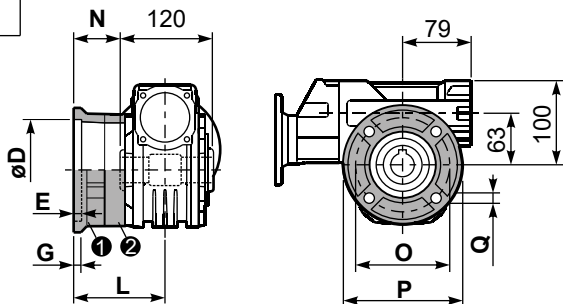

type B	øD	E	G	L	N	O	P	Q	kit code
FC	130 ^{+0.20} / _{+0.15}	7	13	85	25	165	200	13	① K070.9.010 ② -
FL	130 ^{+0.20} / _{+0.15}	7	13	111	51	165	200	13	① K070.9.010 ② K070.0.200
type S	øD	E	G	L	N	O	P	Q	kit code
F1	130 ^{+0.20} / _{+0.15}	7	13	111	51	165	200	13	① KS070.9.014 ② -
F2	115 ^{+0.20} / _{+0.15}	7	13	116	56	150	175	11	① KS063.9.013 ② -
F3	110 ^{+0.035} / ₀	5	13.5	84.5	24.5	130	160	11	① KS070.9.011 ② -

PP6A^{BR}... Reaction arm
Braccio di reazione

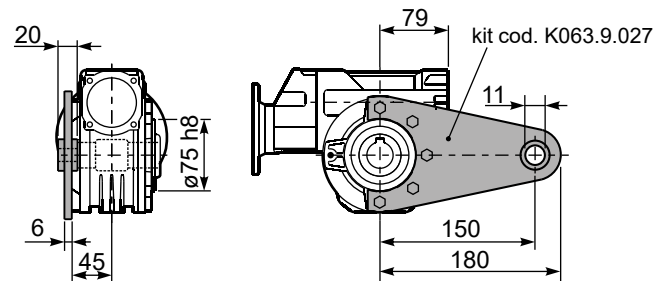

PP6A.....^S... Single Shaft
Albero lento semplice

PP6A.....^D... Double Shaft
Albero lento bisp.

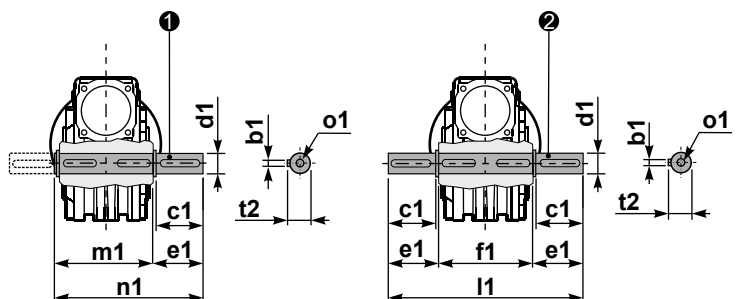

① kit cod. K070.5.028 type B

② kit cod. K070.5.029 type B

R^{P6A}FB... Input shaft
Albero in entrata

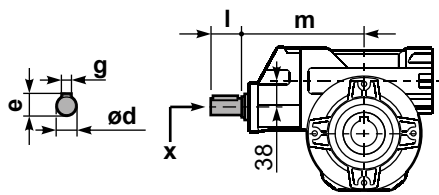

	ød	e	g	l	m	x	
29.9+111	19 h6	21.5	6	35	169.4	M6x16	C40.5.062
139+434	14 h6	16	5	25	154.2	M5x13	C35.5.061

	b1	c1	d1	e1	f1	l1	m1	n1	t2	o1
type B	8	60	28 ^{-0.005} / _{-0.020}	63.5	120	247	127.5	191	31	M8x20
type S	-	-	-	-	-	-	-	-	-	-

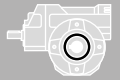

QUICK SELECTION / Selezione veloce

input speed (n_1) = 1400 min⁻¹

Output Speed n_2 [min ⁻¹]	Ratio i	Motor power P_{1M} [kW]	Output torque M_{2M} [Nm]	Service factor f.s.	Nominal power P_{1R} [kW]	Nominal torque M_{2R} [Nm]	Available B5 motor flanges				Available B14 motor flanges			Dynamic efficiency RD	Tooth Module [mm]	Ratios code
							-B	-C	-D	-E	-Q	-R	-T			
							63	71	80	90	71	80	90			
23.5	59.7	1.1	300	1.4	1.5	418					C	C		67	3.5	01
19.4	72.3	1.1	347	1.2	1.3	407					C	C		64	3.1	02
17.1	81.7	1.1	374	1.1	1.2	418					C	C		61	2.7	03
13.3	105	0.75	323	1.2	0.89	385					C	C		60	2.1	04
8.0	176	0.55	415	1.1	0.58	440	B				C	C		63	3.5	05
6.6	213	0.37	322	1.3	0.47	407	B				C	C		60	3.1	06
5.8	240	0.37	321	1.3	0.48	418	B				C	C		53	2.7	07
4.3	328	0.37	438	1.0	0.35	418	B				C	C		53	2.7	08
3.3	422	0.25	374	1.0	0.26	385	B				C	C		52	2.1	09
3.0	466	0.25	358	0.9	0.23	330	B				C	C		45	1.9	10
2.3	605	0.18	297	1.1	0.20	330	B				C	C		40	1.5	11

A) Motor Flanges Available
Flange Motore Disponibili

B) Supplied with Reduction Bushing
Fornito con Bussola di Riduzione

B) Available on Request without reduction bushing
Disponibile a Richiesta senza Bussola di Riduzione

C) Motor Flange Holes Position
Posizione Fori Flangia Motore

EN Unit **P85** is supplied with synthetic oil, providing "long life" lubrication. For mounting position V5-V6 please contact us. See table 1 for lubrication and recommended quantity. In table 2 please see possible radial loads and axial loads on the gearbox.

I Il riduttore tipo **P85** viene fornito lubrificato a vita con olio sintetico. Per posizioni V5-V6 contattare il ns. servizio tecnico. Vedi tab.1 per oli e quantità consigliati. In tab.2 sono presenti i carichi radiali e assiali applicabili al riduttore.

D Für die Lebensdauerschmierung ist das Getriebe der Größe **P85** mit synthetischem Öl befüllt. Bei Einbaulage V5 oder V6 bitten wir um Rücksprache. In Tabelle 1 ist die Schmiermenge und das empfohlene Schmiermittel angegeben. In Tabelle 2 sind die zulässigen Radial- und Axialbelastungen des Getriebes aufgeführt.

F Le réducteur de type **P85** est fourni lubrifié à vie avec de l'huile synthétique. Concernant les positions V5.V6, contactez notre service d'assistance technique. Voir tableau 1 concernant les huiles et les quantités conseillées. Les charges radiales et axiales applicables au réducteur sont précisées dans le tableau 2.

E El reductor tamaño **P85** se suministra, lubricado de por vida con aceite sintético. Para las posiciones V5 y V6 contactar con nuestro servicio técnico. Ver tabla 1, para cantidades y aceites recomendados. En la tabla 2, se encuentran las cargas radiales y axiales admitidas por el reductor.

LUBRICATION P85 Oil

For B3-V5-V6 separate lubrication for A (1.20 l) B (0.14 l) , for B6-B7-B8 common lubrication 0.90 l (A + B).



SHELL Omala S4 WE 320

ENI Telium VSF 320

For all details on lubrication and plugs check our website **tab. 1**
Per maggiori dettagli su lubrificazione e tappi olio vedi il nostro sito web

RADIAL AND AXIAL LOADS

Output shaft

Albero di uscita

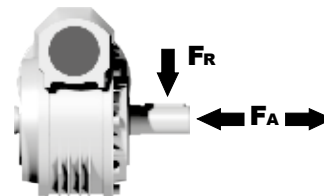

n_2 [min ⁻¹]	FA [N]	FR [N]
75	700	3500
50	800	4000
25	1000	5000
15-6	1160	5800

Input shaft

albero in entrata

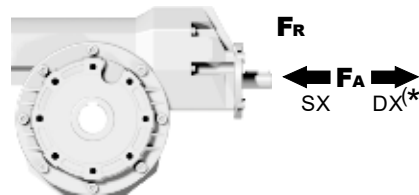

n_1 [min ⁻¹]	FA [N]	FR [N]
1400	108	540

***Strong axial loads in the DX direction are not allowed.**
Non sono consentiti forti carichi assiali con direzione DX

tab. 2

PP85**FB**... Basic wormbox
Riduttore base

Gearbox weight
peso riduttore **19.30 kg**

M. flanges	Kit code	øF	A
63B5	K063.4.041	140	195.2
71B5	K063.4.042	160	193.2
80/90B5	K063.4.043	200	195.2
71B14	K063.4.047	105	193.2
80B14	K063.4.046	120	195.2
90B14	K063.4.041	140	195.2

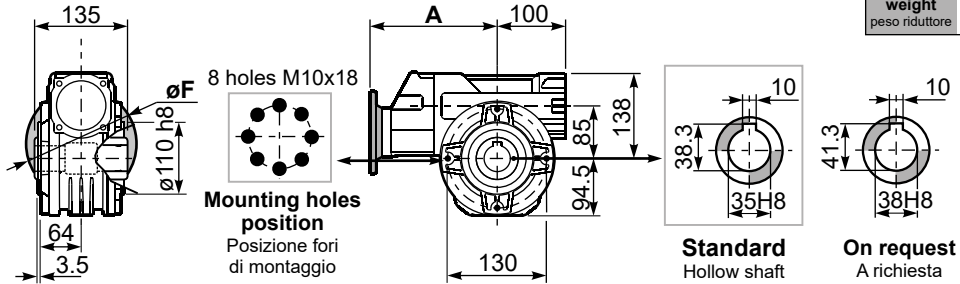

PP85**PA**... Feet
Piedini

PP85**PB**... Feet
Piedini

PP85**PV**... Feet
Piedini

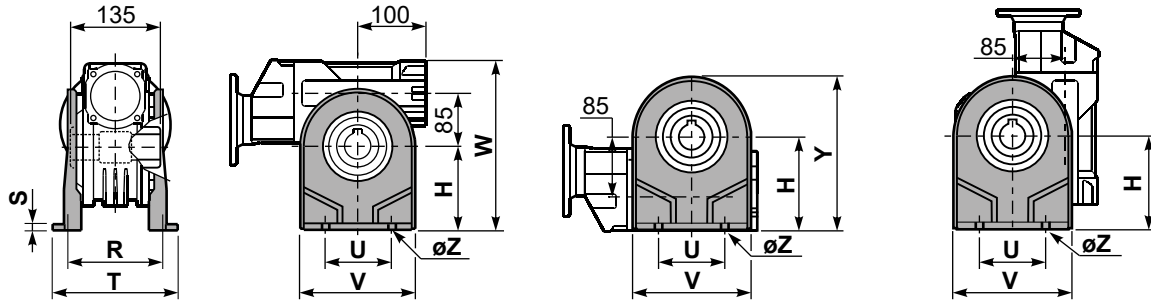

	H	R	S	T	U	V	Y	W	øZ	kit code
type B	142	145	5	182	140	180	236.5	280	ø10.5	K085.9.022
type S	-	-	-	-	-	-	-	-	-	-

PP85**FC**... Output flange
Flangia uscita

PP85**BR**... Reaction arm
Braccio di reazione

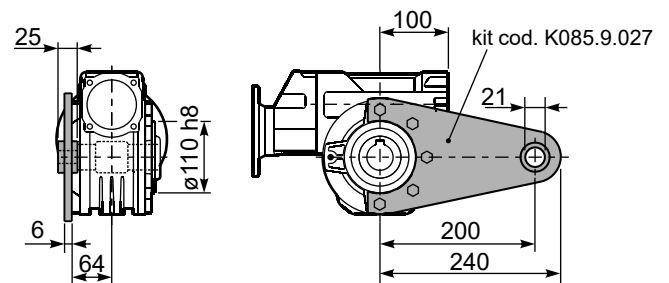
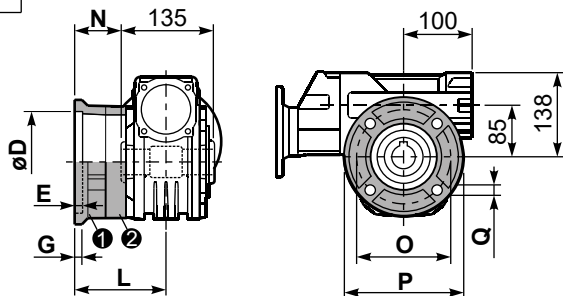

type B	øD	E	G	L	N	O	P	Q	kit code
FC	152 ^{+0.06} / _{+0.00}	5	16	108	40.5	176	205	13	① K085.9.010 ② -
FL	152 ^{+0.06} / _{+0.00}	5	16	148.5	81	176	205	13	① K085.9.010 ② K085.0.201

type S	øD	E	G	L	N	O	P	Q	kit code
F1	130 ^{+0.04} / _{+0.00}	5	13	117.5	50	165	200	11.5	① KS085.9.012 ② -
F2	152 ^{+0.06} / _{+0.00}	5	15	147.5	80	180	205	12.5	① KS085.9.013 ② -
F4	130 ^{+0.04} / _{+0.00}	5	13	106.5	39	165	200	13	① KS085.9.015 ② -

PP85.....**S**... Single Shaft
Albero lento semplice

PP85.....**D**... Double Shaft
Albero lento bisp.

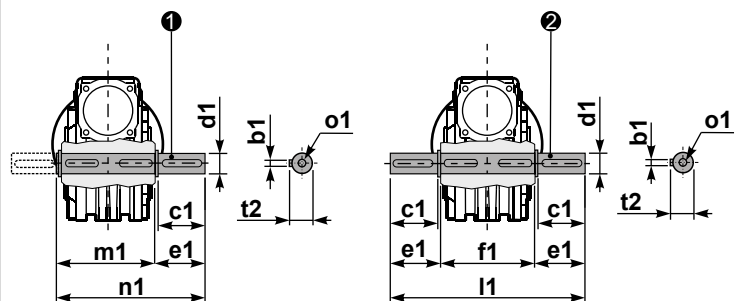

① kit cod. K085.5.028 type B

② kit cod. K085.5.029 type B

RP85**FB**... Input shaft
Albero in entrata

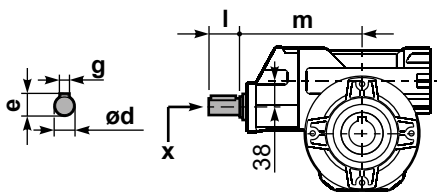

	ød	e	g	l	m	x
type B	19 h6	21.5	6	35	187.5	M6x16
type S	-	-	-	-	-	-

	b1	c1	d1	e1	f1	l1	m1	n1	t2	o1
type B	10	60	35 ^{-0.005} / _{-0.020}	73.5	135	282	141	214.5	38	M10x23
type S	-	-	-	-	-	-	-	-	-	-

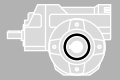

QUICK SELECTION / Selezione veloce

input speed (n_1) = 1400 min⁻¹

Output Speed n_2 [min ⁻¹]	Ratio i	Motor power P_{1M} [kW]	Output torque M_{2M} [Nm]	Service factor f.s.	Nominal power P_{1R} [kW]	Nominal torque M_{2R} [Nm]	Available B5 motor flanges				Available B14 motor flanges			Dynamic efficiency RD	Tooth Module [mm]	Ratios code
							-B	-C	-D	-E	-Q	-R	-T			
							63	71	80	90	71	80	90			
16.8	83.2	1.5	587	1.1	1.7	660					C	C		69	3.5	01
13.9	100.5	1.5	699	0.8	1.3	594					C	C		68	2.9	02
10.6	132	1.1	634	0.9	0.95	550					C	C		64	2.2	03
8.0	176	0.75	666	1.2	0.90	803	B				C	C		74	4.7	04
6.7	208	0.75	766	0.9	0.65	660	B				C	C		72	4.0	05
5.7	245	0.55	634	1.0	0.57	660	B				C	C		69	3.5	06
4.7	296	0.55	755	0.8	0.43	594	B				C	C		68	2.9	07
4.2	334	0.55	865	0.8	0.42	660	B				C	C		69	3.5	08
3.5	403	0.37	692	0.9	0.32	594	B				C	C		68	2.9	09
2.6	529	0.25	577	1.0	0.24	550	B				C	C		64	2.2	10
2.2	624	0.25	628	0.8	0.21	528	B				C	C		59	1.9	11

Motor Flanges Available
Flange Motore Disponibili

B) Supplied with Reduction Bushing
Fornito con Bussola di Riduzione

B) Available on Request without reduction bushing
Disponibile a Richiesta senza Bussola di Riduzione

C) Motor Flange Holes Position
Posizione Fori Flangia Motore

EN Unit **P10** is supplied without lubricant and equipped with a breather, level and drain plugs. User can add mineral oil keeping existing plugs. Should the user wish to fill it with synthetic oil, it is recommended to replace the existing plugs with a closed plug. Primary reduction unit is supplied with closed plugs and lubricated for life with synthetic oil. See table 1 for lubrication and recommended quantity. In table 2 please see possible radial loads and axial loads on the gearbox.

I Il riduttore tipo **P10** è fornito privo di lubrificazione con tappi di sfiato, livello e scarico olio. L'utente può immettere olio minerale mantenendo i tappi esistenti. Se immetterà olio sintetico, dovrà sostituire i tappi esistenti con altri tipo chiuso. La precoppia è fornita con tappi chiusi e lubrificata a vita con olio sintetico. Tab.1 per oli e quantità consigliati. Tab.2 carichi radiali e assiali applicabili al riduttore.

D Das Getriebe der Baugröße **P10** wird ohne Schmiermittel geliefert. Es ist jedoch mit Einfüllschraube, Überdruckventil und Ablassschraube ausgerüstet. Das benötigte mineralische Öl kann über die Einfüllschraube eingefüllt werden. Sollte synthetisches Öl bevorzugt werden, so ist sind das eingebaute Überdruckventil durch eine geschlossenen Schraube zu ersetzen. Die Stirnradvorstufe ist Lebensdauer geschmiert und wird mit synthetischem Öl geliefert. Die Stirnradvorstufe ist komplett geschlossen ohne Füllschrauben. In Tabelle 1 ist die Schmiermenge und das empfohlene Schmiermittel angegeben. In Tabelle 2 sind die zulässigen Radial- und Axialbelastungen des Getriebes aufgeführt.

F Le réducteur de type **P10** est fourni sans lubrification et avec un bouchon de remplissage, de niveau et d'évacuation de l'huile. L'utilisateur peut y verser de l'huile minérale en conservant les bouchons existants. S'il y versera de l'huile synthétique, il devra substituer les bouchons existants avec d'autres bouchons de type fermé. Le précouple est fourni lubrifié à vie avec de l'huile synthétique et avec des bouchons fermés. Voir tableau 1 concernant les huiles et les quantités conseillées. Voir tableau 2 concernant les charges radiales et axiales applicables au réducteur.

E El reductor tamaño **P10** se suministra sin lubricante, provisto de tapones de respiración, nivel y descarga de aceite. El usuario puede utilizar aceite mineral, manteniendo los tapones existentes. Si prefiere utilizar aceite sintético deberá sustituir los tapones existentes por tapones ciegos. La prerreducción se suministra con tapones ciegos, lubricado de por vida con aceite sintético. Ver tabla 1, para cantidades y aceites recomendados. En la tabla 2, se encuentran las cargas radiales y axiales admitidas por el reductor.

B3	B6	B7	B8	V5	V6
1.9/0.14LT	1.35/0.14LT	1.35/0.14LT	2.0/0.14LT	2.0/0.14LT	2.0/0.14LT
SHELL Omala S2 GX 460			ENI Blasias 460		

For all details on lubrication and plugs check our website [www.igus.com](#) **tab. 1**
Per maggiori dettagli su lubrificazione e tappi olio vedi il nostro sito web

RADIAL AND AXIAL LOADS

Output shaft
Albero di uscita

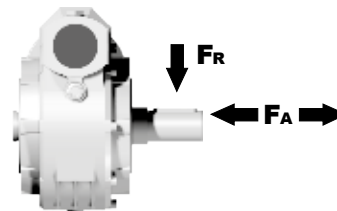

n_2 [min ⁻¹]	FA [N]	FR [N]
75	800	4000
50	920	4600
25	1200	6000
15-6	1400	7000

Input shaft
albero in entrata

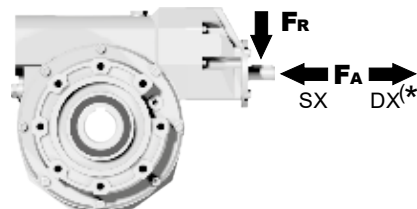

n_1 [min ⁻¹]	FA [N]	FR [N]
1400	150	760

***Strong axial loads in the DX direction are not allowed.**
Non sono consentiti forti carichi assiali con direzione DX

tab. 2

PP10**FB**... Basic wormbox
Riduttore base

Gearbox weight
peso riduttore **41.00 kg**

M. flanges	Kit code	øF	A
63B5	K063.4.041	140	214.7
71B5	K063.4.042	160	212.7
80/90B5	K063.4.043	200	214.7
71B14	K063.4.047	105	212.7
80B14	K063.4.046	120	214.7
90B14	K063.4.041	140	214.7

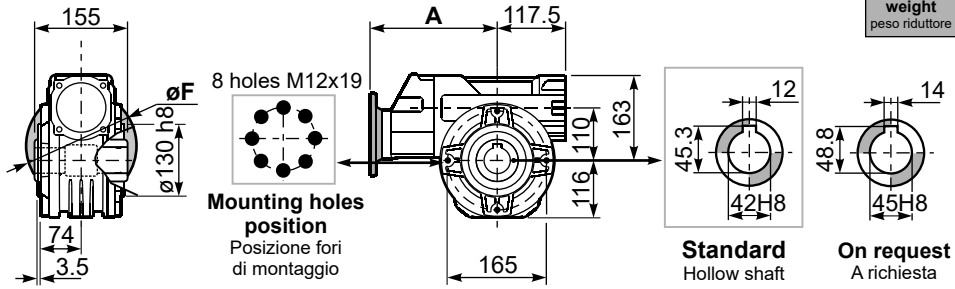

PP10**PA**... Feet
Piedini

PP10**PB**... Feet
Piedini

PP10**PV**... Feet
Piedini

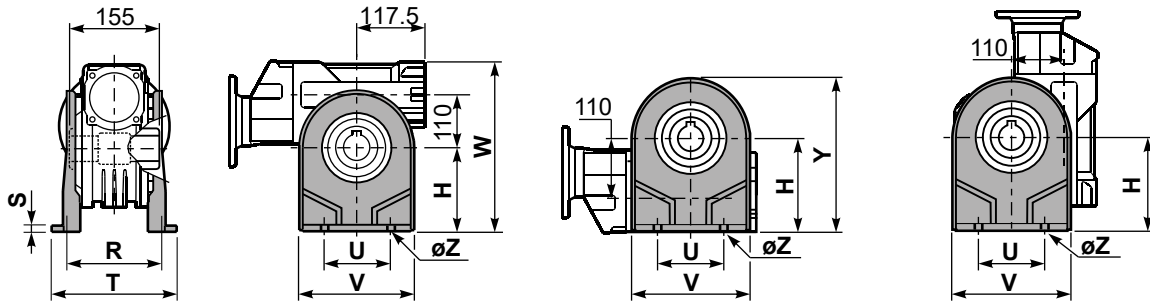

	H	R	S	T	U	V	Y	W	øZ	kit code
type B	170	180	8	224	200	240	286	333	ø13	K110.9.022
type S	-	-	-	-	-	-	-	-	-	-

PP10**FC**... Output flange
Flangia uscita

PP10**BR**... Reaction arm
Braccio di reazione

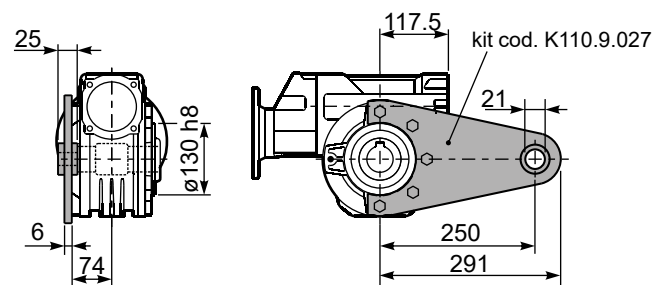
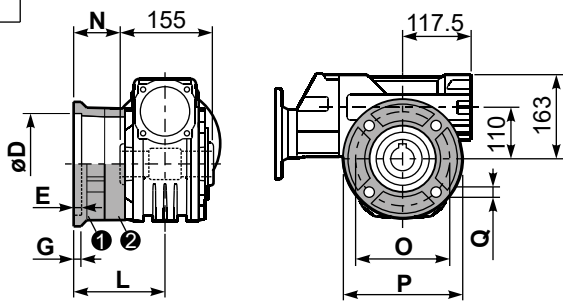

type B	øD	E	G	L	N	O	P	Q	kit code
FC	170 ^{+0.083} / _{+0.043}	11	16.5	131.5	54	230	270	13	① K110.9.010 ② -
FL	170 ^{+0.083} / _{+0.043}	11	16.5	179.5	102	230	270	13	① K110.9.011 ② -

type S	øD	E	G	L	N	O	P	Q	kit code
F1	180 ^{+0.040} / ₀	5	18	150	72.5	215	250	15	① KS110.9.014 ② -
F3	180 ^{+0.040} / ₀	5	18	130	52.5	215	250	15	① KS110.9.013 ② -

PP10.....**S**... Single Shaft
Albero lento semplice

PP10.....**D**... Double Shaft
Albero lento bisp.

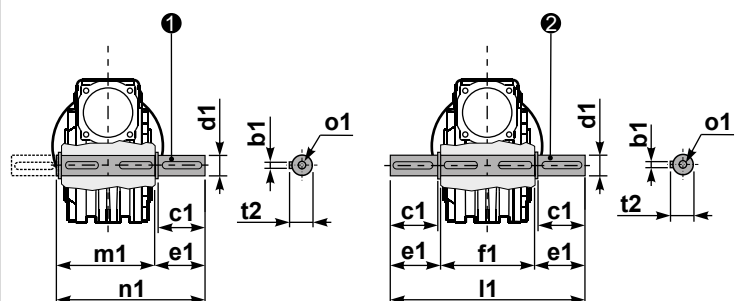

① kit cod. K110.5.028 type B

② kit cod. K110.5.029 type B

RP10**FB**... Input shaft
Albero in entrata

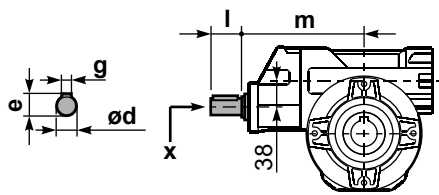

	ød	e	g	l	m	x
type B	19 h6	21.5	6	35	205	M6x16
type S	-	-	-	-	-	-

	b1	c1	d1	e1	f1	l1	m1	n1	t2	o1
type B	12	75	42 ^{-0.005} / _{-0.020}	96.5	155	348	163.5	260	45	M12x32
type S	-	-	-	-	-	-	-	-	-	-

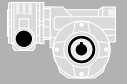

QUICK SELECTION / Selezione veloce

input speed (n_1) = 1400 min⁻¹

Output Speed n_2 [min ⁻¹]	Ratio i	Motor power P_{1M} [kW]	Output torque M_{2M} [Nm]	Service factor f.s.	Nominal power P_{1R} [kW]	Nominal torque M_{2R} [Nm]	Available B5 motor flanges		Available B14 motor flanges		Dynamic efficiency RD	Tooth Module [mm]	 Ratios code
							-A	-B	-O	-P			
							56	63	56	63			
9.3	150	0.06	29	1.2	0.07	35	B		B-C		48	1.44	01
6.7	210	0.06	39	0.9	0.05	35	B		B-C		45	1.44	02
4.7	300	0.06	44	0.8	0.05	35	B		B-C		36	1.44	03
3.1	450	0.06*	35	<0.8	0.03	35	B		B-C		33	1.44	04
2.3	600	0.06*	35	<0.8	0.03	35	B		B-C		30	1.44	05
1.6	900	0.06*	35	<0.8	0.02	35	B		B-C		27	1.44	06
1.2	1200	0.06*	35	<0.8	0.02	35	B		B-C		26	1.44	07
0.8	1830	0.06*	35	<0.8	0.01	35	B		B-C		24	1.44	08
0.6	2400	0.06*	35	<0.8	0.01	35	B		B-C		22	1.44	09

A) Motor Flanges Available
Flange Motore Disponibili

B) Supplied with Reduction Bushing
Fornito con Bussola di Riduzione

B) Available on Request without reduction bushing
Disponibile a Richiesta senza Bussola di Riduzione

C) Motor Flange Holes Position
Posizione Fori Flangia Motore

* Power higher than the maximum one which can be supported by the gearbox. Select according to the torque M_{2R}
Potenza superiore a quella massima sopportabile dal riduttore. Selezionare in base al momento torcente M_{2R}

EN Unit 303 is supplied with synthetic oil, providing "long life" lubrication. For mounting position V5-V6 please contact us. See table 1 for lubrication and recommended quantity. In table 2 please see possible radial loads and axial loads on the gearbox.

I Il riduttore tipo 303 viene fornito lubrificato a vita con olio sintetico. Per posizioni V5-V6 contattare il ns. servizio tecnico. Vedi tab.1 per oli e quantità consigliati. In tab.2 sono presenti i carichi radiali e assiali applicabili al riduttore.

D Für die Lebensdauerschmierung ist das Getriebe der Größe 303 mit synthetischem Öl befüllt. Bei Einbaulage V5 oder V6 bitten wir um Rücksprache. In Tabelle 1 ist die Schmiermenge und das empfohlene Schmiermittel angegeben. In Tabelle 2 sind die zulässigen Radial- und Axialbelastungen des Getriebes aufgeführt.

F Le réducteur de type 303 est fourni lubrifié à vie avec de l'huile synthétique. Concernant les positions V5.V6, contactez notre service d'assistance technique. Voir tableau 1 concernant les huiles et les quantités conseillées. Les charges radiales et axiales applicables au réducteur sont précisées dans le tableau 2.

E El reductor tamaño 303 se suministra, lubricado de por vida con aceite sintético. Para las posiciones V5 y V6 contactar con nuestro servicio técnico. Ver tabla 1, para cantidades y aceites recomendados. En la tabla 2, se encuentran las cargas radiales y axiales admitidas por el reductor.

LUBRICATION 303 Oil 0.03 Lt. 0.03 Lt.

Quantity 0.03/0.03 Lt.

SHELL Omala S4 WE 320	ENI Telium VSF 320
------------------------------	---------------------------

For all details on lubrication and plugs check our website **tab. 1**
Per maggiori dettagli su lubrificazione e tappi olio vedi il nostro sito web

RADIAL AND AXIAL LOADS

Output shaft
Albero di uscita

n_2 [min ⁻¹]	FA [N]	FR [N]
25	300	1800
15	400	2000

Input shaft
albero in entrata

n_1 [min ⁻¹]	FA [N]	FR [N]
1400	20	100

*Strong axial loads in the DX direction are not allowed.
Non sono consentiti forti carichi assiali con direzione DX

tab. 2

P303FB... Basic wormbox
Riduttore base

Gearbox weight
peso riduttore **2.15 kg**

M. flanges	Kit code	øF	A
56B5	K030.4.041	120	61.5
63B5	K030.4.042	140	62.5
56B14	K030.4.046	80	61.5
63B14	K030.4.045	90	62.5

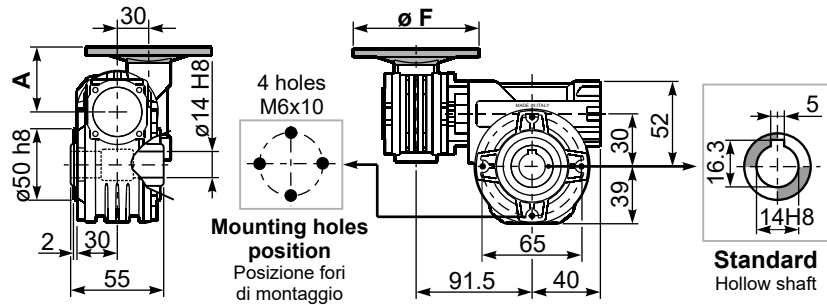

P303PA... Feet
Piedini

P303PB... Feet
Piedini

P303PV... Feet
Piedini

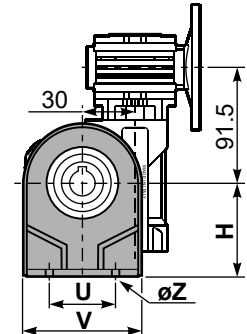
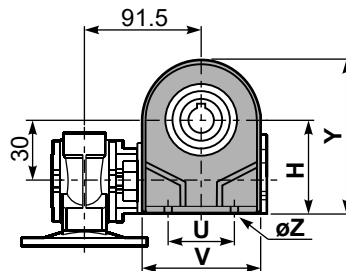
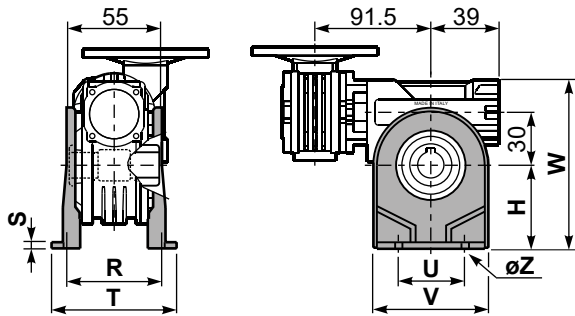

	H	R	S	T	U	V	Y	W	øZ	kit code
type B	55	66	3	87	50	90	94	107	ø6.5	K030.9.022
type S	52	66	3	87	52	90	91	104	ø6.5	KS030.9.023

P303FC... Output flange
Flangia uscita

P303BR... Reaction arm
Braccio di reazione

kit cod. K045.9.027

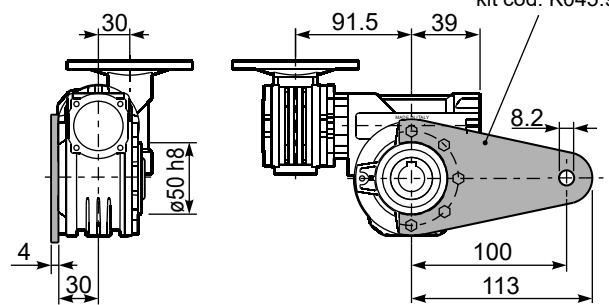
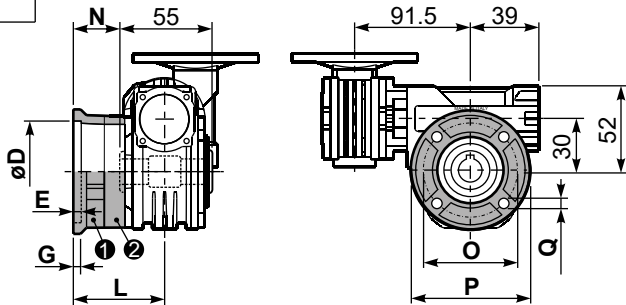

type B	øD	E	G	L	N	O	P	Q	kit code
FC	50 ^{+0.15} / _{+0.05}	6	6	50.5	23	68	80	7	1 K030.9.010 2 -
FL	60 ^{+0.15} / _{+0.05}	6	6	55.5	28	87	110	8.5	1 K045.9.010 2 -
type S	øD	E	G	L	N	O	P	Q	kit code
F1	40 ^{+0.15} / _{+0.10}	3.5	5.5	49	21.5	56	80	6.5	1 KS030.9.012 2 -

P303....S... Single Shaft
Albero lento semplice

P303....D... Double Shaft
Albero lento bisp.

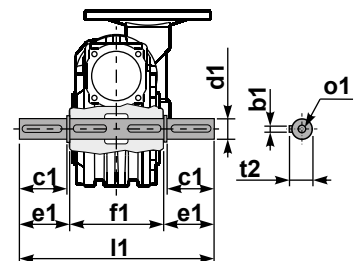
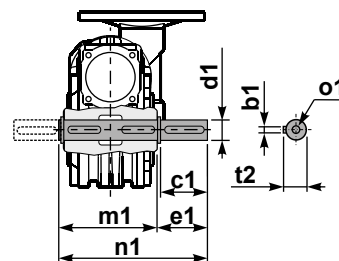

1 kit cod. K030.5.028 type B

2 kit cod. K030.5.029 type B

R303FB... Input shaft
Albero in entrata

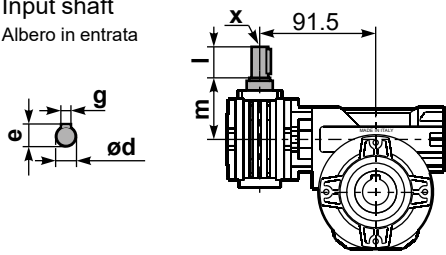

	ød	e	g	l	m	x	kit code
type B	9 h6	10.2	3	20	58	-	K030.5.006 PAM63
type S	-	-	-	-	-	-	-

	b1	c1	d1	e1	f1	l1	m1	n1	t2	o1
type B	5	25	14 ^{-0.005} / _{-0.020}	35.5	55	126	59	94.5	15.8	M5x14
type S	-	-	-	-	-	-	-	-	-	-

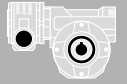

QUICK SELECTION / Selezione veloce

input speed (n_1) = 1400 min⁻¹

Output Speed n_2 [min ⁻¹]	Ratio i	Motor power P_{1M} [kW]	Output torque M_{2M} [Nm]	Service factor f.s.	Nominal power P_{1R} [kW]	Nominal torque M_{2R} [Nm]	Available B5 motor flanges		Available B14 motor flanges		Dynamic efficiency RD	Tooth Module [mm]	 Ratios code
							-A	-B	-O	-P			
							56	63	56	63			
10.0	140	0.12	57	1.2	0.14	69	B		B-C		50	2.2	01
7.0	200	0.12	79	0.9	0.11	69	B		B-C		48	2.2	02
5.0	280	0.06	52	1.3	0.08	69	B		B-C		45	2.4	03
3.3	420	0.06	62	1.1	0.07	69	B		B-C		36	1.6	04
2.5	560	0.06	76	0.9	0.05	69	B		B-C		33	2.5	05
1.9	740	0.06	91	0.8	0.05	69	B		B-C		30	1.8	06
1.5	920	0.06*	69	<0.8	0.04	69	B		B-C		27	1.5	07
1.3	1120	0.06*	69	<0.8	0.03	69	B		B-C		26	2.5	08
0.9	1480	0.06*	69	<0.8	0.03	69	B		B-C		24	1.8	09
0.8	1840	0.06*	69	<0.8	0.02	69	B		B-C		22	1.5	10
0.6	2400	0.06*	69	<0.8	0.02	69	B		B-C		21	1.2	11

Motor Flanges Available
Flange Motore Disponibili

B) Supplied with Reduction Bushing
Fornito con Bussola di Riduzione

B) Available on Request without reduction bushing
Disponibile a Richiesta senza Bussola di Riduzione

C) Motor Flange Holes Position
Posizione Fori Flangia Motore

* Power higher than the maximum one which can be supported by the gearbox. Select according to the torque M_{2R}
Potenza superiore a quella massima sopportabile dal riduttore. Selezionare in base al momento torcente M_{2R}

EN Unit **453** is supplied with synthetic oil, providing "long life" lubrication. For mounting position V5-V6 please contact us. See table 1 for lubrication and recommended quantity. In table 2 please see possible radial loads and axial loads on the gearbox.

I Il riduttore tipo **453** viene fornito lubrificato a vita con olio sintetico. Per posizioni V5-V6 contattare il ns. servizio tecnico. Vedi tab.1 per oli e quantità consigliati. In tab.2 sono presenti i carichi radiali e assiali applicabili al riduttore.

D Für die Lebensdauerschmierung ist das Getriebe der Größe **453** mit synthetischem Öl befüllt. Bei Einbaulage V5 oder V6 bitten wir um Rücksprache. In Tabelle 1 ist die Schmiermenge und das empfohlene Schmiermittel angegeben. In Tabelle 2 sind die zulässigen Radial- und Axialbelastungen des Getriebes aufgeführt.

F Le réducteur de type **453** est fourni lubrifié à vie avec de l'huile synthétique. Concernant les positions V5.V6, contactez notre service d'assistance technique. Voir tableau 1 concernant les huiles et les quantités conseillées. Les charges radiales et axiales applicables au réducteur sont précisées dans le tableau 2.

E El reductor tamaño **453** se suministra, lubricado de por vida con aceite sintético. Para las posiciones V5 y V6 contactar con nuestro servicio técnico. Ver tabla 1, para cantidades y aceites recomendados. En la tabla 2, se encuentran las cargas radiales y axiales admitidas por el reductor.

LUBRICATION 453 Oil 0.09 Lt. 0.03 Lt.

Quantity 0.09/0.03 Lt.

SHELL Omala S4 WE 320

ENI Telium VSF 320

For all details on lubrication and plugs check our website **tab. 1**
Per maggiori dettagli su lubrificazione e tappi olio vedi il nostro sito web

RADIAL AND AXIAL LOADS

Output shaft
Albero di uscita

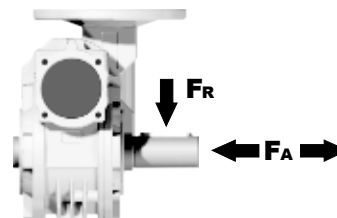

n_2 [min ⁻¹]	FA [N]	FR [N]
25	300	1800
15	400	2000

Input shaft
albero in entrata

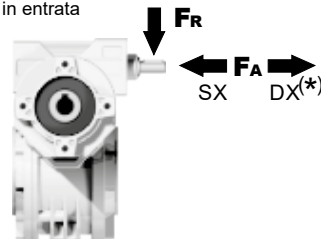

n_1 [min ⁻¹]	FA [N]	FR [N]
1400	20	100

*Strong axial loads in the DX direction are not allowed.
Non sono consentiti forti carichi assiali con direzione DX

tab. 2

3D dimensions on the Web

P453FB... Basic wormbox
Riduttore base

Gearbox weight
peso riduttore **3.60 kg**

M. flanges	Kit code	øF	A
56B5	K030.4.041	120	61.5
63B5	K030.4.042	140	62.5
56B14	K030.4.046	80	61.5
63B14	K030.4.045	90	62.5

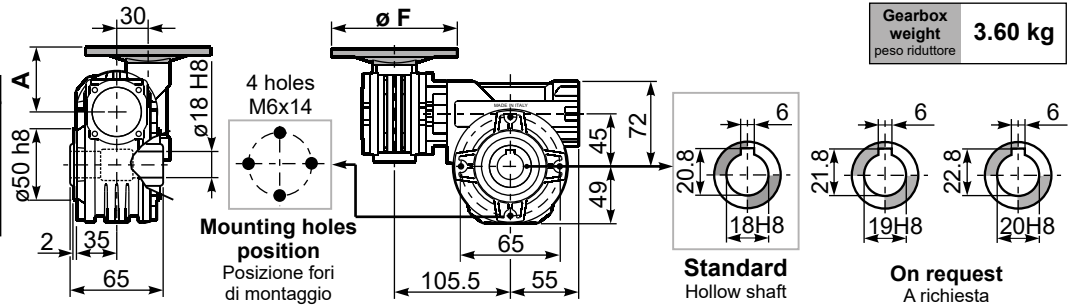

P453PA... Feet
Piedini

P453PB... Feet
Piedini

P453PV... Feet
Piedini

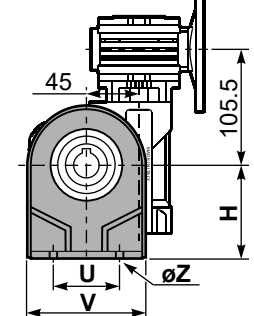
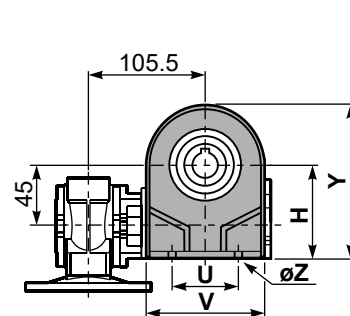
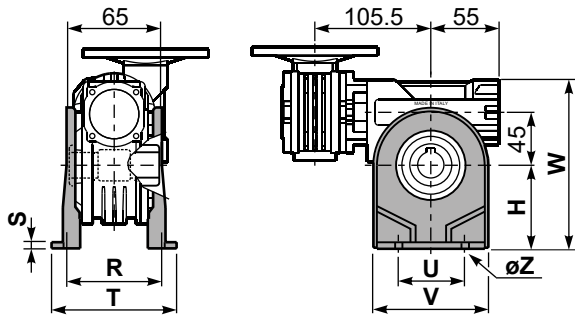

	H	R	S	T	U	V	Y	W	øZ	kit code
type B	72	81	3	100	52	98	121	144	ø10.5	K045.9.022
type S	71	84	8	100	70	90	120	143	ø8	KS045.9.023

P453FC... Output flange
Flangia uscita

P453BR... Reaction arm
Braccio di reazione

kit cod. K045.9.027

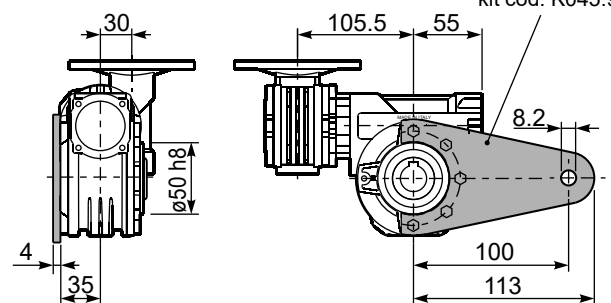
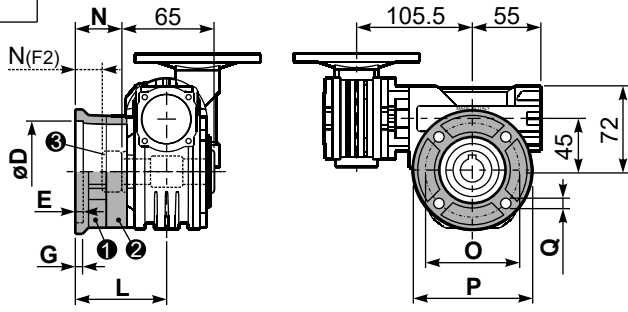

type B	øD	E	G	L	N	O	P	Q	kit code
FC	60 ^{+0.15} / _{+0.05}	9	9	60.5	28	87	110	8.5	① K045.9.010 ② -
FL	60 ^{+0.15} / _{+0.05}	9	9	90.5	58	87	110	8.5	① K045.9.010 ② K045.0.200

type S	øD	E	G	L	N	O	P	Q	kit code
F1	95 ^{+0.20} / _{+0.15}	4	11	73.5	41	115	140	9	① KS045.9.013 ② -
F2	60 ^{+0.15} / _{+0.05}	9	9	60.5	19	87	110	8.5	① KS045.9.010 ② S045.0.204
F3	80 ^{+0.030} / ₀	3	8	51.5	19	100	120	9	① KS045.9.014 ② -

P453.....S... Single Shaft
Albero lento semplice

P453.....D... Double Shaft
Albero lento bisp.

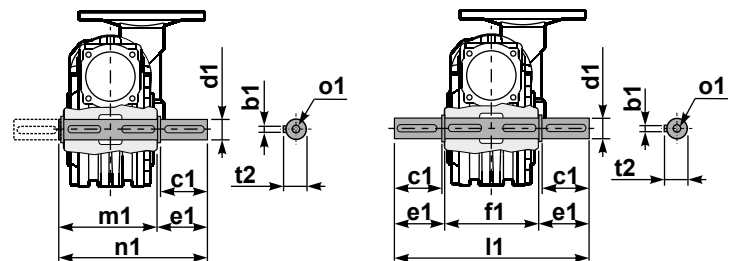

① kit cod. K045.5.028 type B
kit cod. KS045.5.030 type S

② kit cod. K045.5.029 type B

R453FB... Input shaft
Albero in entrata

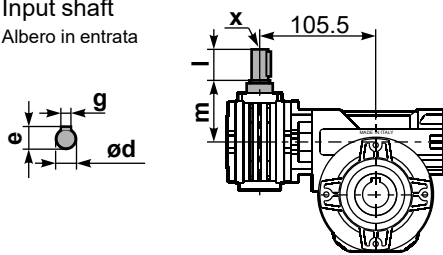

	ød	e	g	l	m	x	kit code
type B	9 h6	10.2	3	20	58	-	① K030.5.006 PAM63 ② -
type S	-	-	-	-	-	-	① - ② -

	b1	c1	d1	e1	f1	l1	m1	n1	t2	o1
type B	6	32	18 ^{-0.005} / _{-0.020}	43	65	151	70	113	20.5	M6x18
type S	6	40	19 ^{-0.005} / _{-0.020}	58.5	-	-	70	128.5	21.5	M8x20

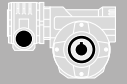

QUICK SELECTION / Selezione veloce

input speed (n_1) = 1400 min⁻¹

Output Speed n_2 [min ⁻¹]	Ratio i	Motor power P_{1M} [kW]	Output torque M_{2M} [Nm]	Service factor f.s.	Nominal power P_{1R} [kW]	Nominal torque M_{2R} [Nm]	Available B5 motor flanges		Available B14 motor flanges		Dynamic efficiency RD	Tooth Module [mm]	 Ratios code
							-A	-B	-O	-P			
							56	63	56	63			
5.6	252	0.12	97	1.1	0.14	109	B		B-C		47	2.1	01
3.9	360	0.12	124	0.9	0.11	109	B		B-C		42	2.1	02
2.6	540	0.09	129	0.8	0.08	109	B		B-C		39	2.1	03
1.9	720	0.06	106	1.0	0.06	109	B		B-C		36	2.1	04
1.6	860	0.06	113	1.0	0.06	109	B		B-C		32	1.8	05
1.2	1200	0.06	133	0.8	0.05	109	B		B-C		27	1.3	06
1.0	1440	0.06*	109	<0.8	0.04	109	B		B-C		26	2.1	07
0.8	1720	0.06*	109	<0.8	0.04	109	B		B-C		25	1.8	08
0.6	2400	0.06*	109	<0.8	0.03	104	B		B-C		21	1.3	09

A) Motor Flanges Available
Flange Motore Disponibili

B) Supplied with Reduction Bushing
Fornito con Bussola di Riduzione

B) Available on Request without reduction bushing
Disponibile a Richiesta senza Bussola di Riduzione

C) Motor Flange Holes Position
Posizione Fori Flangia Motore

* Power higher than the maximum one which can be supported by the gearbox. Select according to the torque M_{2R}
Potenza superiore a quella massima sopportabile dal riduttore. Selezionare in base al momento torcente M_{2R}

EN Unit 503 is supplied with synthetic oil, providing "long life" lubrication. For mounting position V5-V6 please contact us. See table 1 for lubrication and recommended quantity. In table 2 please see possible radial loads and axial loads on the gearbox.

I Il riduttore tipo 503 viene fornito lubrificato a vita con olio sintetico. Per posizioni V5-V6 contattare il ns. servizio tecnico. Vedi tab.1 per oli e quantità consigliati. In tab.2 sono presenti i carichi radiali e assiali applicabili al riduttore.

D Für die Lebensdauerschmierung ist das Getriebe der Größe 503 mit synthetischem Öl befüllt. Bei Einbaulage V5 oder V6 bitten wir um Rücksprache. In Tabelle 1 ist die Schmiermenge und das empfohlene Schmiermittel angegeben. In Tabelle 2 sind die zulässigen Radial- und Axialbelastungen des Getriebes aufgeführt.

F Le réducteur de type 503 est fourni lubrifié à vie avec de l'huile synthétique. Concernant les positions V5.V6, contactez notre service d'assistance technique. Voir tableau 1 concernant les huiles et les quantités conseillées. Les charges radiales et axiales applicables au réducteur sont précisées dans le tableau 2.

E El reductor tamaño 503 se suministra, lubricado de por vida con aceite sintético. Para las posiciones V5 y V6 contactar con nuestro servicio técnico. Ver tabla 1, para cantidades y aceites recomendados. En la tabla 2, se encuentran las cargas radiales y axiales admitidas por el reductor.

LUBRICATION 503 Oil 0.14 Lt. 0.03 Lt.

Quantity 0.14/0.03 Lt.

SHELL Omala S4 WE 320	ENI Telium VSF 320
------------------------------	---------------------------

For all details on lubrication and plugs check our website **tab. 1**
Per maggiori dettagli su lubrificazione e tappi olio vedi il nostro sito web

RADIAL AND AXIAL LOADS

Output shaft
Albero di uscita

n_2 [min ⁻¹]	FA [N]	FR [N]
25	480	2500
15	560	2800

Input shaft
albero in entrata

n_1 [min ⁻¹]	FA [N]	FR [N]
1400	20	100

*Strong axial loads in the DX direction are not allowed.
Non sono consentiti forti carichi assiali con direzione DX

tab. 2

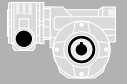

QUICK SELECTION / Selezione veloce

input speed (n_1) = 1400 min⁻¹

Output Speed n_2 [min ⁻¹]	Ratio i	Motor power P_{1M} [kW]	Output torque M_{2M} [Nm]	Service factor f.s.	Nominal power P_{1R} [kW]	Nominal torque M_{2R} [Nm]	Available B5 motor flanges		Available B14 motor flanges		Dynamic efficiency RD	Tooth Module [mm]	Ratios code
							-A	-B	-O	-P			
							56	63	56	63			
5.6	252	0.18	142	1.6	0.29	230	B		B-C		46	2.7	01
3.9	360	0.18	181	1.3	0.23	230	B		B-C		41	2.7	02
2.6	540	0.12	164	1.4	0.17	230	B		B-C		37	2.7	03
1.9	720	0.12	200	1.1	0.14	230	B		B-C		34	2.7	04
1.3	1080	0.12	265	0.9	0.10	230	B		B-C		30	2.7	05
1.0	1440	0.12*	230	<0.8	0.09	230	B		B-C		27	2.7	06
0.5	2745	0.12*	230	<0.8	0.05	230	B		B-C		23	2.1	07

A) Motor Flanges Available
Flange Motore Disponibili

B) Supplied with Reduction Bushing
Fornito con Bussola di Riduzione

B) Available on Request without reduction bushing
Disponibile a Richiesta senza Bussola di Riduzione

C) Motor Flange Holes Position
Posizione Fori Flangia Motore

* Power higher than the maximum one which can be supported by the gearbox. Select according to the torque M_{2R}
Potenza superiore a quella massima sopportabile dal riduttore. Selezionare in base al momento torcente M_{2R}

EN Unit **633** is supplied with synthetic oil, providing "long life" lubrication. For mounting position V5-V6 please contact us. See table 1 for lubrication and recommended quantity. In table 2 please see possible radial loads and axial loads on the gearbox.

I Il riduttore tipo **633** viene fornito lubrificato a vita con olio sintetico. Per posizioni V5-V6 contattare il ns. servizio tecnico. Vedi tab.1 per oli e quantità consigliati. In tab.2 sono presenti i carichi radiali e assiali applicabili al riduttore.

D Für die Lebensdauerschmierung ist das Getriebe der Größe **633** mit synthetischem Öl befüllt. Bei Einbaulage V5 oder V6 bitten wir um Rücksprache. In Tabelle 1 ist die Schmiermenge und das empfohlene Schmiermittel angegeben. In Tabelle 2 sind die zulässigen Radial - und Axialbelastungen des Getriebes aufgeführt.

F Le réducteur de type **633** est fourni lubrifié à vie avec de l'huile synthétique. Concernant les positions V5.V6, contactez notre service d'assistance technique. Voir tableau 1 concernant les huiles et les quantités conseillées. Les charges radiales et axiales applicables au réducteur sont précisées dans le tableau 2.

E El reductor tamaño **633** se suministra, lubricado de por vida con aceite sintético. Para las posiciones V5 y V6 contactar con nuestro servicio técnico. Ver tabla 1, para cantidades y aceites recomendados. En la tabla 2, se encuentran las cargas radiales y axiales admitidas por el reductor.

LUBRICATION 633 Oil 0.40 Lt. Quantity 0.40/0.03 Lt.

SHELL Omala S4 WE 320	ENI Telium VSF 320
------------------------------	---------------------------

For all details on lubrication and plugs check our website **tab. 1**
Per maggiori dettagli su lubrificazione e tappi olio vedi il nostro sito web

RADIAL AND AXIAL LOADS

Output shaft
Albero di uscita

n_2 [min ⁻¹]	FA [N]	FR [N]
25	700	3800
15	800	4000

Input shaft
albero in entrata

n_1 [min ⁻¹]	FA [N]	FR [N]
1400	20	100

*Strong axial loads in the DX direction are not allowed.
Non sono consentiti forti carichi assiali con direzione DX

tab. 2

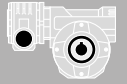

QUICK SELECTION / Selezione veloce

input speed (n_1) = 1400 min⁻¹

Output Speed n_2 [min ⁻¹]	Ratio i	Motor power P_{1M} [kW]	Output torque M_{2M} [Nm]	Service factor f.s.	Nominal power P_{1R} [kW]	Nominal torque M_{2R} [Nm]	Available B5 motor flanges		Available B14 motor flanges			Dynamic efficiency RD	Tooth Module [mm]	 Ratios code
							-B	-C	-O	-P	-Q			
							63	71	56	63	71			
5.6	252	0.25	198	1.3	0.33	265	B		B-C	B-C		46	2.7	01
3.9	360	0.18	186	1.4	0.26	265	B		B-C	B-C		42	2.7	02
2.8	504	0.18	241	1.1	0.20	265	B		B-C	B-C		39	2.7	03
1.9	756	0.12	204	1.3	0.16	265	B		B-C	B-C		33	2.7	04
1.4	1008	0.12	256	1.0	0.12	265	B		B-C	B-C		31	2.7	05
1.1	1332	0.12*	265	<0.8	0.10	265	B		B-C	B-C		30	2.7	06
0.8	1656	0.12*	265	<0.8	0.08	265	B		B-C	B-C		28	2.7	07
0.6	2160	0.12*	265	<0.8	0.07	265	B		B-C	B-C		26	2.7	08
0.6	2520	0.12*	265	<0.8	0.06	265	B		B-C	B-C		25	2.7	09

A) Motor Flanges Available
Flange Motore Disponibili

B) Supplied with Reduction Bushing
Fornito con Bussola di Riduzione

B) Available on Request without reduction bushing
Disponibile a Richiesta senza Bussola di Riduzione

C) Motor Flange Holes Position
Posizione Fori Flangia Motore

* Power higher than the maximum one which can be supported by the gearbox. Select according to the torque M_{2R}
Potenza superiore a quella massima sopportabile dal riduttore. Selezionare in base al momento torcente M_{2R}

EN Unit **634** is supplied with synthetic oil, providing "long life" lubrication. For mounting position V5-V6 please contact us. See table 1 for lubrication and recommended quantity. In table 2 please see possible radial loads and axial loads on the gearbox.

I Il riduttore tipo **634** viene fornito lubrificato a vita con olio sintetico. Per posizioni V5-V6 contattare il ns. servizio tecnico. Vedi tab.1 per oli e quantità consigliati. In tab.2 sono presenti i carichi radiali e assiali applicabili al riduttore.

D Für die Lebensdauerschmierung ist das Getriebe der Größe **634** mit synthetischem Öl befüllt. Bei Einbaulage V5 oder V6 bitten wir um Rücksprache. In Tabelle 1 ist die Schmiermenge und das empfohlene Schmiermittel angegeben. In Tabelle 2 sind die zulässigen Radial- und Axialbelastungen des Getriebes aufgeführt.

F Le réducteur de type **634** est fourni lubrifié à vie avec de l'huile synthétique. Concernant les positions V5.V6, contactez notre service d'assistance technique. Voir tableau 1 concernant les huiles et les quantités conseillées. Les charges radiales et axiales applicables au réducteur sont précisées dans le tableau 2.

E El reductor tamaño **634** se suministra, lubricado de por vida con aceite sintético. Para las posiciones V5 y V6 contactar con nuestro servicio técnico. Ver tabla 1, para cantidades y aceites recomendados. En la tabla 2, se encuentran las cargas radiales y axiales admitidas por el reductor.

LUBRICATION 634 Oil 0.40 Lt.
Quantity 0.40/0.09 Lt.

SHELL Omala S4 WE 320	ENI Telium VSF 320
------------------------------	---------------------------

For all details on lubrication and plugs check our website **tab. 1**
Per maggiori dettagli su lubrificazione e tappi olio vedi il nostro sito web

RADIAL AND AXIAL LOADS

Output shaft
Albero di uscita

n_2 [min ⁻¹]	FA [N]	FR [N]
25	700	3800
15	800	4000

Input shaft
albero in entrata

n_1 [min ⁻¹]	FA [N]	FR [N]
1400	42	210

***Strong axial loads in the DX direction are not allowed.**
Non sono consentiti forti carichi assiali con direzione DX

tab. 2

P634FB... Basic wormbox
Riduttore base

Gearbox weight
peso riduttore **8.90 kg**

M. flanges	Kit code	øF	A
63B5	K050.4.041	138	74
71B5	K050.4.042	160	71.5
56B14	KC40.4.049	80	71.5
63B14	K050.4.047	90	74
71B14	K050.4.045	105	71.5

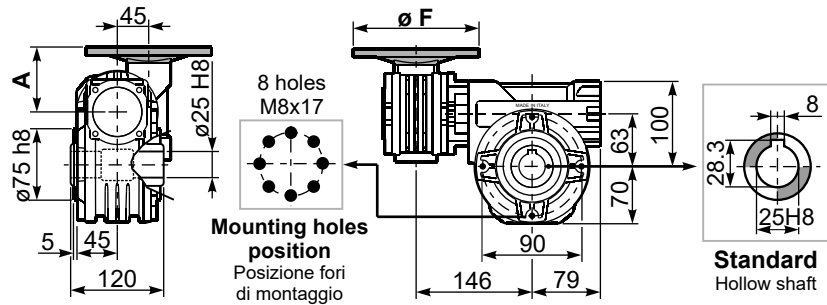

8 holes
M8x17
Mounting holes
position
Posizione fori
di montaggio

Standard
Hollow shaft

P634PA... Feet
Piedini

P634PB... Feet
Piedini

P634PV... Feet
Piedini

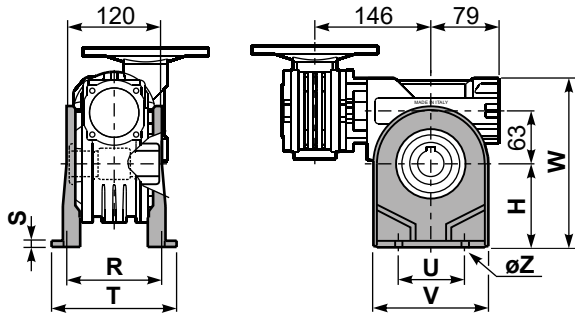

	H	R	S	T	U	V	Y	W	øZ	kit code
type B	100	111	4	144	95	133	170	200	ø10.5	K063.9.022
type S	-	-	-	-	-	-	-	-	-	-

P634FC... Output flange
Flangia uscita

P634BR... Reaction arm
Braccio di reazione

kit cod. K063.9.027

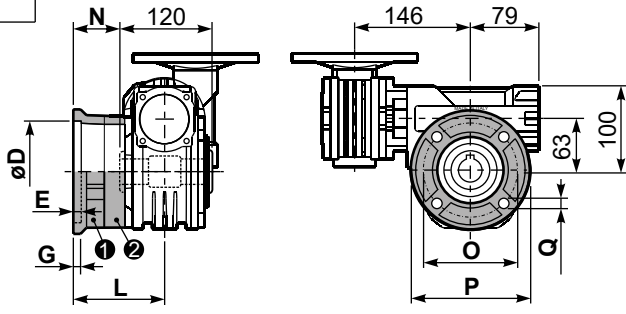

type B	øD	E	G	L	N	O	P	Q	kit code
FC	115 ^{+0.20} / _{+0.15}	7	13	86	26	150	175	11	① K063.9.010 ② -
FL	115 ^{+0.20} / _{+0.15}	7	13	116	56	150	175	11	① K063.9.010 ② K063.0.200
type S	øD	E	G	L	N	O	P	Q	kit code
F1	130 ^{+0.20} / _{+0.15}	7	13	102	42	165	200	13	① KS070.9.013 ② -
F2	115 ^{+0.20} / _{+0.15}	7	13	116	56	150	175	11	① KS063.9.013 ② -
F3	110 ^{+0.035} / ₀	5	11	82	22	130	160	10	① KS063.9.011 ② -

P634.....S... Single Shaft
Albero lento semplice

P634.....D... Double Shaft
Albero lento bisp.

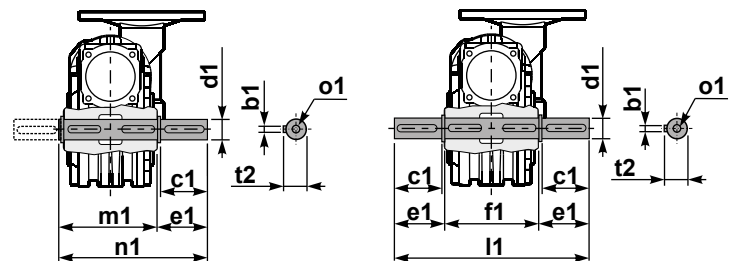

① kit cod. K063.5.028 type B

② kit cod. K063.5.029 type B

R634FB... Input shaft
Albero in entrata

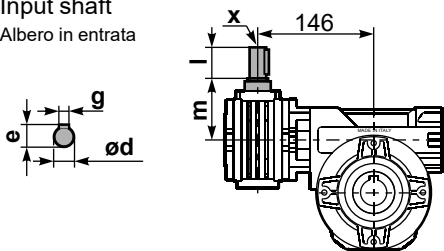

	ød	e	g	l	m	x	kit code
type B	11 h6	12.5	4	30	68	-	① ② K045.5.006 PAM71
type S	-	-	-	-	-	-	① ② -

	b1	c1	d1	e1	f1	l1	m1	n1	t2	o1
type B	8	60	25 ^{-0.005} / _{-0.020}	63.2	120	246.4	126.8	190	28	M8x20
type S	-	-	-	-	-	-	-	-	-	-

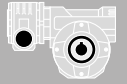

QUICK SELECTION / Selezione veloce

input speed (n_1) = 1400 min⁻¹

Output Speed n_2 [min ⁻¹]	Ratio i	Motor power P_{1M} [kW]	Output torque M_{2M} [Nm]	Service factor f.s.	Nominal power P_{1R} [kW]	Nominal torque M_{2R} [Nm]	Available B5 motor flanges		Available B14 motor flanges		Dynamic efficiency RD	Tooth Module [mm]	Ratios code
							-A	-B	-O	-P			
							56	63	56	63			
5.6	252	0.18	142	2.0	0.37	290	B		B-C		46	2.7	01
3.9	360	0.18	181	1.6	0.29	290	B		B-C		41	2.7	02
2.6	540	0.18	245	1.2	0.21	290	B		B-C		37	2.7	03
1.9	720	0.12	200	1.4	0.17	290	B		B-C		34	2.7	04
1.3	1080	0.12	265	1.1	0.13	290	B		B-C		30	2.7	05
1.0	1440	0.12	318	0.9	0.11	290	B		B-C		27	2.7	06
0.5	2745	0.12*	242	<0.8	0.06	242	B		B-C		23	2.1	07

A) Motor Flanges Available
Flange Motore Disponibili

B) Supplied with Reduction Bushing
Fornito con Bussola di Riduzione

B) Available on Request without reduction bushing
Disponibile a Richiesta senza Bussola di Riduzione

C) Motor Flange Holes Position
Posizione Fori Flangia Motore

* Power higher than the maximum one which can be supported by the gearbox. Select according to the torque M_{2R}
Potenza superiore a quella massima sopportabile dal riduttore. Selezionare in base al momento torcente M_{2R}

EN Unit **6A3** is supplied with synthetic oil, providing "long life" lubrication. For mounting position V5-V6 please contact us. See table 1 for lubrication and recommended quantity. In table 2 please see possible radial loads and axial loads on the gearbox.

I Il riduttore tipo **6A3** viene fornito lubrificato a vita con olio sintetico. Per posizioni V5-V6 contattare il ns. servizio tecnico. Vedi tab.1 per oli e quantità consigliati. In tab.2 sono presenti i carichi radiali e assiali applicabili al riduttore.

D Für die Lebensdauerschmierung ist das Getriebe der Größe **6A3** mit synthetischem Öl befüllt. Bei Einbaulage V5 oder V6 bitten wir um Rücksprache. In Tabelle 1 ist die Schmiermenge und das empfohlene Schmiermittel angegeben. In Tabelle 2 sind die zulässigen Radial - und Axialbelastungen des Getriebes aufgeführt.

F Le réducteur de type **6A3** est fourni lubrifié à vie avec de l'huile synthétique. Concernant les positions V5.V6, contactez notre service d'assistance technique. Voir tableau 1 concernant les huiles et les quantités conseillées. Les charges radiales et axiales applicables au réducteur sont précisées dans le tableau 2.

E El reductor tamaño **6A3** se suministra, lubricado de por vida con aceite sintético. Para las posiciones V5 y V6 contactar con nuestro servicio técnico. Ver tabla 1, para cantidades y aceites recomendados. En la tabla 2, se encuentran las cargas radiales y axiales admitidas por el reductor.

LUBRICATION 6A3 Oil 0.40 Lt. 0.03 Lt.

Quantity 0.40/0.03 Lt.

SHELL Omala S4 WE 320

ENI Telium VSF 320

For all details on lubrication and plugs check our website **tab. 1**
Per maggiori dettagli su lubrificazione e tappi olio vedi il nostro sito web

RADIAL AND AXIAL LOADS

Output shaft
Albero di uscita

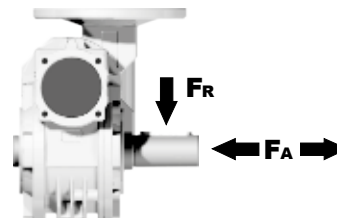

n_2 [min ⁻¹]	FA [N]	FR [N]
25	700	3800
15	800	4000

Input shaft
albero in entrata

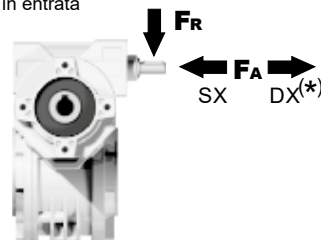

n_1 [min ⁻¹]	FA [N]	FR [N]
1400	20	100

*Strong axial loads in the DX direction are not allowed.
Non sono consentiti forti carichi assiali con direzione DX

tab. 2

P6A3FB... Basic wormbox
Riduttore base

M. flanges	Kit code	øF	A
56B5	K030.4.041	120	61.5
63B5	K030.4.042	140	62.5
56B14	K030.4.046	80	61.5
63B14	K030.4.045	90	62.5

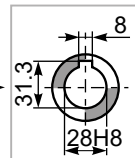
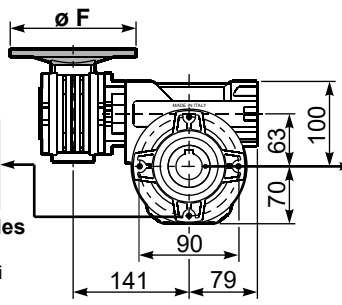
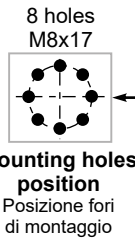
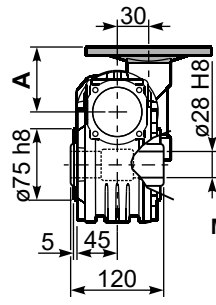

Standard
Hollow shaft

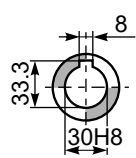

On request
A richiesta

Gearbox weight
peso riduttore **8.90 kg**

P6A3PA... Feet
Piedini

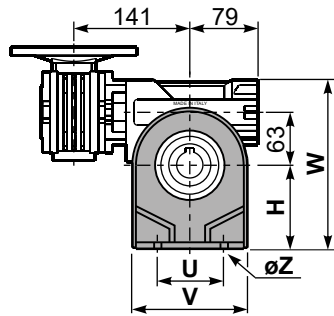
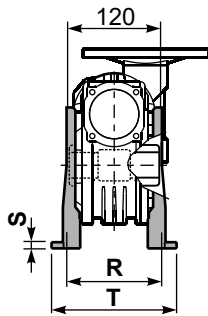

P6A3PB... Feet
Piedini

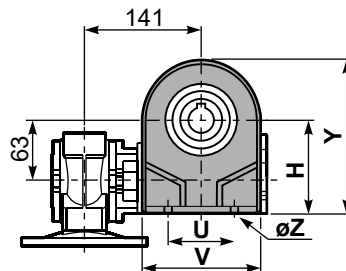

P6A3PV... Feet
Piedini

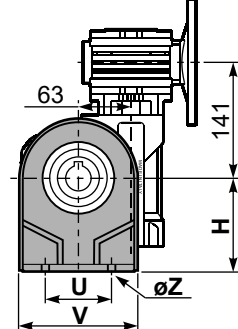

	H	R	S	T	U	V	Y	W	øZ	kit code
type B	115	115	12	142	120	156	185	215	ø11	K070.9.022
type S	-	-	-	-	-	-	-	-	-	-

P6A3FC... Output flange
Flangia uscita

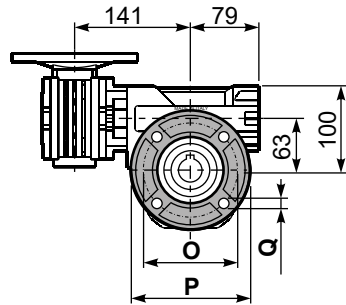
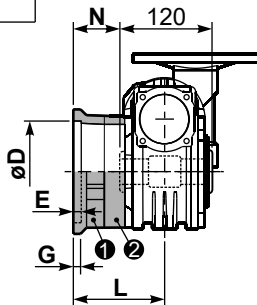

type B	øD	E	G	L	N	O	P	Q	kit code
FC	130 ^{+0.20} / _{+0.15}	7	13	85	25	165	200	13	1 K070.9.010 2 -
FL	130 ^{+0.20} / _{+0.15}	7	13	111	51	165	200	13	1 K070.9.010 2 K070.0.200
type S	øD	E	G	L	N	O	P	Q	kit code
F1	130 ^{+0.20} / _{+0.15}	7	13	111	51	165	200	13	1 KS070.9.014 2 -
F2	115 ^{+0.20} / _{+0.15}	7	13	116	56	150	175	11	1 KS063.9.013 2 -
F3	110 ^{+0.035} / ₀	5	13.5	84.5	24.5	130	160	11	1 KS070.9.011 2 -

P6A3BR... Reaction arm
Braccio di reazione

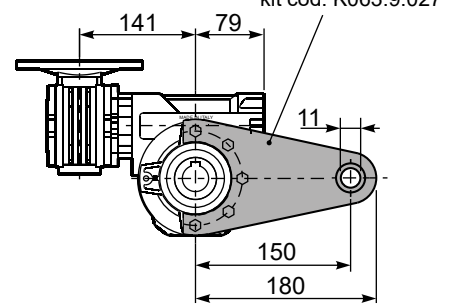
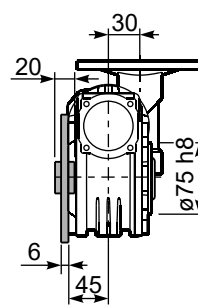

P6A3....S... Single Shaft
Albero lento semplice

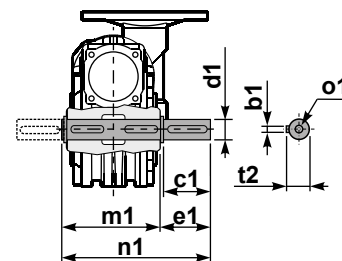

P6A3....D... Double Shaft
Albero lento bisp.

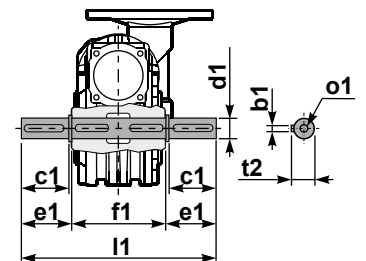

1 kit cod. K070.5.028 type B

2 kit cod. K070.5.029 type B

R6A3FB... Input shaft
Albero in entrata

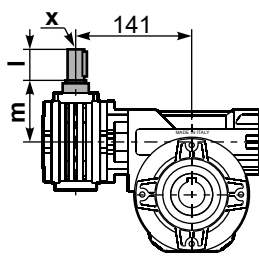
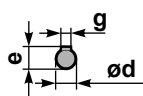

	ød	e	g	l	m	x	kit code
type B	9 h6	10.2	3	20	58	-	1 K030.5.006 PAM63 2 -
type S	-	-	-	-	-	-	1 - 2 -

	b1	c1	d1	e1	f1	l1	m1	n1	t2	o1
type B	8	60	28 ^{-0.005} / _{-0.020}	63.5	120	247	127.5	191	31	M8x20
type S	-	-	-	-	-	-	-	-	-	-

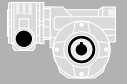

QUICK SELECTION / Selezione veloce

input speed (n_1) = 1400 min⁻¹

Output Speed n_2 [min ⁻¹]	Ratio i	Motor power P_{1M} [kW]	Output torque M_{2M} [Nm]	Service factor f.s.	Nominal power P_{1R} [kW]	Nominal torque M_{2R} [Nm]	Available B5 motor flanges		Available B14 motor flanges			Dynamic efficiency RD	Tooth Module [mm]	 Ratios code
							-B	-C	-O	-P	-Q			
							63	71	56	63	71			
5.6	252	0.25	198	1.5	0.38	304	B		B-C	B-C		46	2.7	01
3.9	360	0.25	258	1.2	0.29	304	B		B-C	B-C		42	2.7	02
2.8	504	0.18	241	1.3	0.23	304	B		B-C	B-C		39	2.7	03
1.9	756	0.12	204	1.5	0.18	304	B		B-C	B-C		33	2.7	04
1.4	1008	0.12	256	1.2	0.14	304	B		B-C	B-C		31	2.7	05
1.1	1332	0.12	327	0.9	0.11	304	B		B-C	B-C		30	2.7	06
0.8	1656	0.12*	304	<0.8	0.10	304	B		B-C	B-C		28	2.7	07
0.6	2160	0.12*	304	<0.8	0.08	304	B		B-C	B-C		26	2.7	08
0.6	2520	0.12*	304	<0.8	0.07	304	B		B-C	B-C		25	2.7	09

A) Motor Flanges Available
Flange Motore Disponibili

B) Supplied with Reduction Bushing
Fornito con Bussola di Riduzione

B) Available on Request without reduction bushing
Disponibile a Richiesta senza Bussola di Riduzione

C) Motor Flange Holes Position
Posizione Fori Flangia Motore

* Power higher than the maximum one which can be supported by the gearbox. Select according to the torque M_{2R}
Potenza superiore a quella massima sopportabile dal riduttore. Selezionare in base al momento torcente M_{2R}

EN Unit **6A4** is supplied with synthetic oil, providing "long life" lubrication. For mounting position V5-V6 please contact us. See table 1 for lubrication and recommended quantity. In table 2 please see possible radial loads and axial loads on the gearbox.

I Il riduttore tipo **6A4** viene fornito lubrificato a vita con olio sintetico. Per posizioni V5-V6 contattare il ns. servizio tecnico. Vedi tab.1 per oli e quantità consigliati. In tab.2 sono presenti i carichi radiali e assiali applicabili al riduttore.

D Für die Lebensdauerschmierung ist das Getriebe der Größe **6A4** mit synthetischem Öl befüllt. Bei Einbaulage V5 oder V6 bitten wir um Rücksprache. In Tabelle 1 ist die Schmiermenge und das empfohlene Schmiermittel angegeben. In Tabelle 2 sind die zulässigen Radial- und Axialbelastungen des Getriebes aufgeführt.

F Le réducteur de type **6A4** est fourni lubrifié à vie avec de l'huile synthétique. Concernant les positions V5.V6, contactez notre service d'assistance technique. Voir tableau 1 concernant les huiles et les quantités conseillées. Les charges radiales et axiales applicables au réducteur sont précisées dans le tableau 2.

E El reductor tamaño **6A4** se suministra, lubricado de por vida con aceite sintético. Para las posiciones V5 y V6 contactar con nuestro servicio técnico. Ver tabla 1, para cantidades y aceites recomendados. En la tabla 2, se encuentran las cargas radiales y axiales admitidas por el reductor.

■ LUBRICATION 6A4 Oil 0.40 Lt. 0.09 Lt.

Quantity 0.40/0.09 Lt.

SHELL Omala S4 WE 320

ENI Telium VSF 320

For all details on lubrication and plugs check our website tab. 1
Per maggiori dettagli su lubrificazione e tappi olio vedi il nostro sito web

■ RADIAL AND AXIAL LOADS

Output shaft
Albero di uscita

n_2 [min ⁻¹]	FA [N]	FR [N]
25	700	3800
15	800	4000

Input shaft
albero in entrata

n_1 [min ⁻¹]	FA [N]	FR [N]
1400	42	210

*Strong axial loads in the DX direction are not allowed.
Non sono consentiti forti carichi assiali con direzione DX

tab. 2

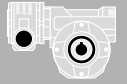

QUICK SELECTION / Selezione veloce

input speed (n_1) = 1400 min⁻¹

Output Speed n_2 [min ⁻¹]	Ratio i	Motor power P_{1M} [kW]	Output torque M_{2M} [Nm]	Service factor f.s.	Nominal power P_{1R} [kW]	Nominal torque M_{2R} [Nm]	Available B5 motor flanges		Available B14 motor flanges			Dynamic efficiency RD	Tooth Module [mm]	Ratios code
							-B	-C	-O	-P	-Q			
							63	71	56	63	71			
10	140	0.37	205	1.8	0.66	368	B		B-C	B-C		58	4.5	01
7.1	196	0.37	257	1.4	0.53	368	B		B-C	B-C		52	4.7	02
5.0	280	0.37	332	1.6	0.58	518	B		B-C	B-C		47	4.7	03
3.6	392	0.37	435	1.2	0.44	518	B		B-C	B-C		44	4.7	04
2.4	588	0.25	371	1.4	0.35	518	B		B-C	B-C		37	4.7	05
1.8	784	0.25	455	1.1	0.28	518	B		B-C	B-C		34	4.7	06
1.4	1036	0.18	420	1.2	0.22	518	B		B-C	B-C		33	4.7	07
1.1	1288	0.18	474	1.1	0.20	518	B		B-C	B-C		30	4.7	08
0.7	1960	0.12	449	1.2	0.14	518	B		B-C	B-C		28	4.7	09
0.5	2856	0.12	584	0.9	0.11	518	B		B-C	B-C		25	4.7	10

Motor Flanges Available
Flange Motore Disponibili

B) Supplied with Reduction Bushing
Fornito con Bussola di Riduzione

Available on Request without reduction bushing
Disponibile a Richiesta senza Bussola di Riduzione

C) Motor Flange Holes Position
Posizione Fori Flangia Motore

EN Unit **854** is supplied with synthetic oil, providing "long life" lubrication. For mounting position V5-V6 please contact us. See table 1 for lubrication and recommended quantity. In table 2 please see possible radial loads and axial loads on the gearbox.

I Il riduttore tipo **854** viene fornito lubrificato a vita con olio sintetico. Per posizioni V5-V6 contattare il ns. servizio tecnico. Vedi tab.1 per oli e quantità consigliati. In tab.2 sono presenti i carichi radiali e assiali applicabili al riduttore.

D Für die Lebensdauerschmierung ist das Getriebe der Größe **854** mit synthetischem Öl befüllt. Bei Einbaulage V5 oder V6 bitten wir um Rücksprache. In Tabelle 1 ist die Schmiermenge und das empfohlene Schmiermittel angegeben. In Tabelle 2 sind die zulässigen Radial- und Axialbelastungen des Getriebes aufgeführt.

F Le réducteur de type **854** est fourni lubrifié à vie avec de l'huile synthétique. Concernant les positions V5.V6, contactez notre service d'assistance technique. Voir tableau 1 concernant les huiles et les quantités conseillées. Les charges radiales et axiales applicables au réducteur sont précisées dans le tableau 2.

E El reductor tamaño **854** se suministra, lubricado de por vida con aceite sintético. Para las posiciones V5 y V6 contactar con nuestro servicio técnico. Ver tabla 1, para cantidades y aceites recomendados. En la tabla 2, se encuentran las cargas radiales y axiales admitidas por el reductor.

LUBRICATION 854 Oil 1.2 Lt. 0.09 Lt.

Quantity 1.2/0.09 Lt.

SHELL Omala S4 WE 320

ENI Telium VSF 320

For all details on lubrication and plugs check our website **tab. 1**
Per maggiori dettagli su lubrificazione e tappi olio vedi il nostro sito web

RADIAL AND AXIAL LOADS

Output shaft
Albero di uscita

n_2 [min ⁻¹]	FA [N]	FR [N]
25	1000	5000
15	1160	5800

Input shaft
albero in entrata

n_1 [min ⁻¹]	FA [N]	FR [N]
1400	42	210

*Strong axial loads in the DX direction are not allowed.
Non sono consentiti forti carichi assiali con direzione DX

tab. 2

P854FB... Basic wormbox
Riduttore base

M. flanges	Kit code	øF	A
63B5	K050.4.041	138	74
71B5	K050.4.042	160	71.5
56B14	KC40.4.049	80	71.5
63B14	K050.4.047	90	74
71B14	K050.4.045	105	71.5

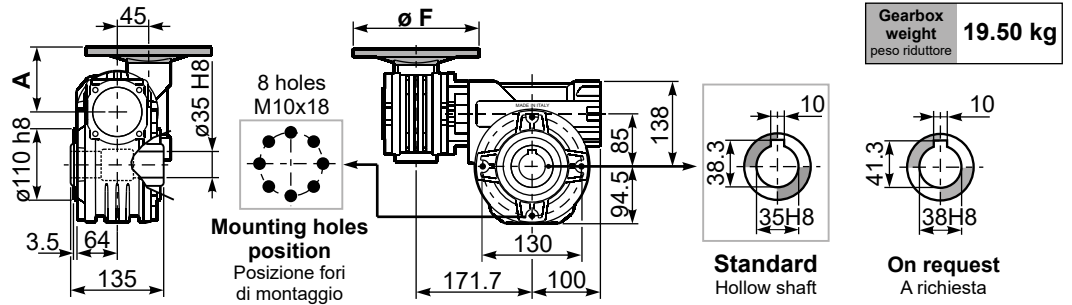

P854PA... Feet
Piedini

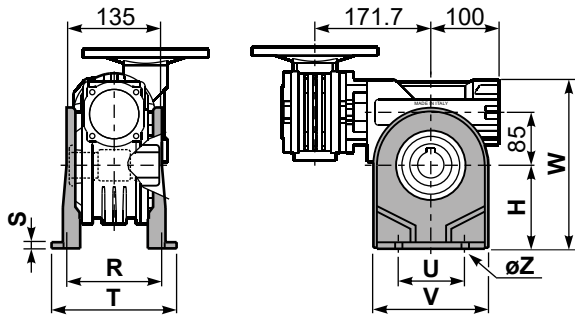

	H	R	S	T	U	V	Y	W	øZ	kit code
type B	142	145	5	182	140	180	236.5	280	ø10.5	K085.9.022
type S	-	-	-	-	-	-	-	-	-	-

P854PB... Feet
Piedini

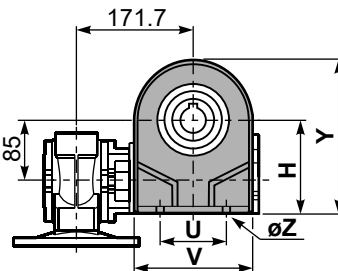

P854PV... Feet
Piedini

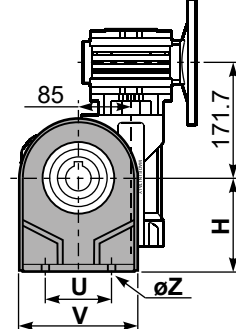

P854FC... Output flange
Flangia uscita

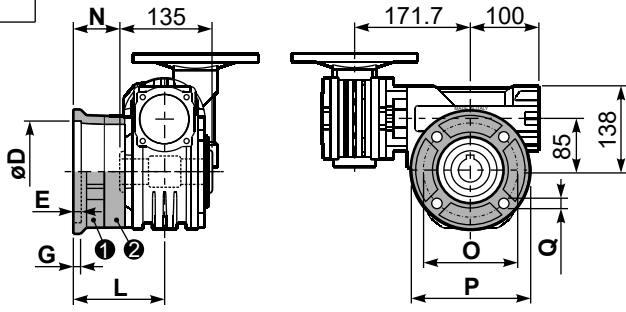

type B	øD	E	G	L	N	O	P	Q	kit code
FC	152 ^{+0.06} / _{+0.00}	5	16	108	40.5	176	205	13	① K085.9.010 ② -
FL	152 ^{+0.06} / _{+0.00}	5	16	148.5	81	176	205	13	① K085.9.010 ② K085.0.201
type S	øD	E	G	L	N	O	P	Q	kit code
F1	130 ^{+0.040} / ₀	5	13	117.5	50	165	200	11.5	① KS085.9.012 ② -
F2	152 ^{+0.06} / ₀	5	15	147.5	80	180	205	12.5	① KS085.9.013 ② -
F4	130 ^{+0.040} / ₀	5	13	106.5	39	165	200	13	① KS085.9.015 ② -

P854BR... Reaction arm
Braccio di reazione

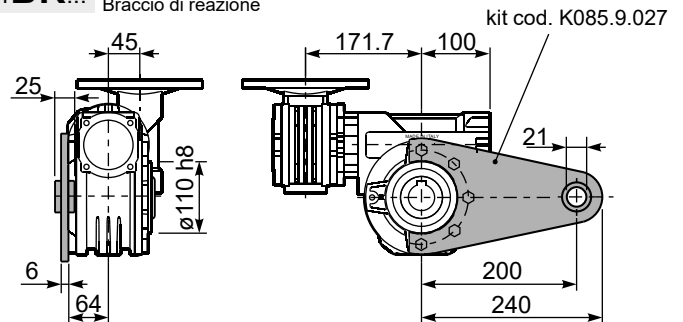

P854.....S... Single Shaft
Albero lento semplice

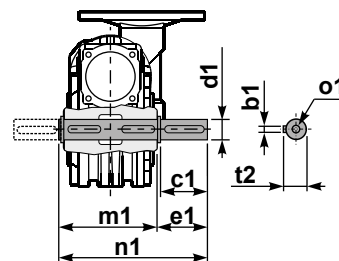

① kit cod. K085.5.028 type B

P854.....D... Double Shaft
Albero lento bisp.

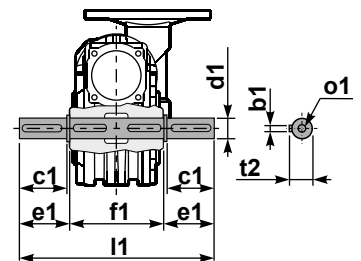

② kit cod. K085.5.029 type B

R854FB... Input shaft
Albero in entrata

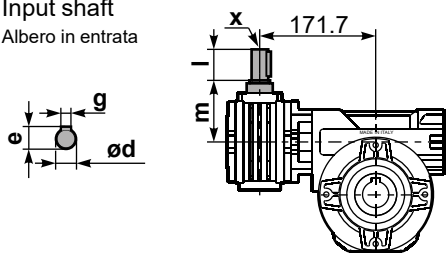

	ød	e	g	l	m	x	kit code
type B	11 h6	12.5	4	30	68	-	① K045.5.006 PAM71 ② -
type S	-	-	-	-	-	-	-

	b1	c1	d1	e1	f1	l1	m1	n1	t2	o1
type B	10	60	35 ^{-0.005} / _{-0.020}	73.5	135	282	141	214.5	38	M10x23
type S	-	-	-	-	-	-	-	-	-	-

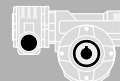

QUICK SELECTION / Selezione veloce

input speed (n_1) = 1400 min⁻¹

Output Speed n_2 [min ⁻¹]	Ratio i	Motor power P_{1M} [kW]	Output torque M_{2M} [Nm]	Service factor f.s.	Nominal power P_{1R} [kW]	Nominal torque M_{2R} [Nm]	Available B5 motor flanges			Available B14 motor flanges				Dynamic efficiency RD	Tooth Module [mm]	Ratios code
							-B	-C	-D	-O	-P	-Q	-R			
							63	71	80	56	63	71	80			
6.7	210	0.75	591	1.5	1.1	863	B	B			B-C	B		55	5.6	01
4.7	300	0.75	752	1.3	0.97	978	B	B			B-C	B		49	5.6	02
3.3	420	0.55	741	1.3	0.73	978	B	B			B-C	B		47	5.6	03
2.6	540	0.55	851	1.1	0.63	978	B	B			B-C	B		42	5.6	04
1.8	780	0.37	748	1.3	0.48	978	B	B			B-C	B		38	5.6	05
1.3	1080	0.37	1009	1.0	0.36	978	B			B-C	B-C			37	5.6	06
1.1	1290	0.25	770	1.3	0.32	978	B			B-C	B-C			35	5.6	07
0.8	1800	0.25	921	1.1	0.27	978	B			B-C	B-C			30	5.6	08
0.7	2040	0.18	751	1.3	0.23	978	B			B-C	B-C			30	5.6	09
0.6	2400	0.18	825	1.2	0.21	978	B			B-C	B-C			28	5.6	10
0.5	3000	0.18	958	1.0	0.18	978	B			B-C	B-C			26	5.6	11

Motor Flanges Available
Flange Motore Disponibili

B) Supplied with Reduction Bushing
Fornito con Bussola di Riduzione

B) Available on Request without reduction bushing
Disponibile a Richiesta senza Bussola di Riduzione



C) Motor Flange Holes Position
Posizione Fori Flangia Motore

EN Unit 115 is supplied without lubricant and equipped with a breather, level and drain plugs. User can add mineral oil keeping existing plugs. Should the user wish to fill it with synthetic oil, it is recommended to replace the existing plugs with a type that are closed. Gearbox 050 is supplied lubricated for life. See tab.1 for oils and recommended quantity. In tab.2 there are radial loads and axial loads applicable to the gearbox.

I Il riduttore tipo 115 è fornito di lubrificazione con tappi di sfiato, livello e scarico olio. L'utente può immettere olio minerale mantenendo i tappi esistenti. Se immetterà olio sintetico, dovrà sostituire i tappi esistenti con altri tipo chiuso. Il riduttore 050 è fornito lubrificato a vita con olio sintetico. Tab.1 per oli e quantità consigliati. Tab.2 carichi radiali e assiali applicabili al riduttore.

D Das Getriebe der Baugröße 115 wird ohne Schmiermittel geliefert. Es ist jedoch mit Einfüllschraube, Überdruckventil und Ablassschraube ausgerüstet. Das benötigte mineralische Öl kann über die Einfüllschraube eingefüllt werden. Sollte synthetisches Öl bevorzugt werden, so ist sind das eingebaute Überdruckventil durch eine geschlossenen Schraube zu ersetzen. Das Getriebe der Baugröße 050 ist lebensdauer geschmiert. In Tabelle 1 ist die Schmiermenge und das empfohlene Schmiermittel angegeben. In Tabelle 2 sind die zulässigen Radial - und Axialbelastungen des Getriebes aufgeführt.

F Le réducteur de type 115 est fourni sans lubrification et avec un bouchon de remplissage, de niveau et d'évacuation de l'huile. L'utilisateur peut y verser de l'huile minérale en conservant les bouchons existants. S'il y versera de l'huile synthétique, il devra substituer les bouchons existants avec d'autres bouchons de type fermé. Le réducteur de type 050 est fourni lubrifié à vie avec de l'huile synthétique. Voir tableau 1 concernant les huiles et les quantités conseillées. Voir tableau 2 concernant les charges radiales et axiales applicables au réducteur.

E El reductor tamaño 115 se suministra sin lubricante, provisto de tapones de respiración, nivel y descarga de aceite. El usuario puede utilizar aceite mineral, manteniendo los tapones existentes. Si prefiere utilizar aceite sintético deberá sustituir los tapones existentes por tapones ciegos. El reductor 050 se suministra lubricado de por vida con aceite sintético. Ver tabla 1, para cantidades y aceites recomendados. En la tabla 2, se encuentran las cargas radiales y axiales admitidas por el reductor.

B3	B6	B7	B8	V5	V6
1.9/0.14 LT	1.35/0.14 LT	1.35/0.14 LT	2.0/0.14 LT	2.0/0.14 LT	2.0/0.14 LT
SHELL Omala S2 GX 460			ENI Blasias 460		

For all details on lubrication and plugs check our website [www.enigearboxes.com](#) tab. 1
Per maggiori dettagli su lubrificazione e tappi olio vedi il nostro sito web

RADIAL AND AXIAL LOADS

Output shaft

Albero di uscita

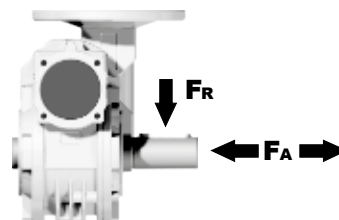

n_2 [min ⁻¹]	FA [N]	FR [N]
25	1200	6000
15	1400	7000

Input shaft

albero in entrata

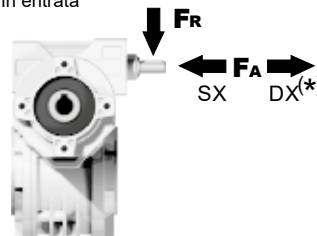

n_1 [min ⁻¹]	FA [N]	FR [N]
1400	76	380

*Strong axial loads in the DX direction are not allowed.
Non sono consentiti forti carichi assiali con direzione DX

tab. 2

P115FB... Basic wormbox
Riduttore base

M. flanges	Kit code	øF	A
63B5	K050.4.041	138	78.5
71B5	K050.4.042	160	76
80B5	K050.4.043	200	76.5
56B14	KC40.4.049	80	76
63B14	K050.4.047	90	78.5
71B14	K050.4.045	105	76
80B14	K050.4.046	120	76.5

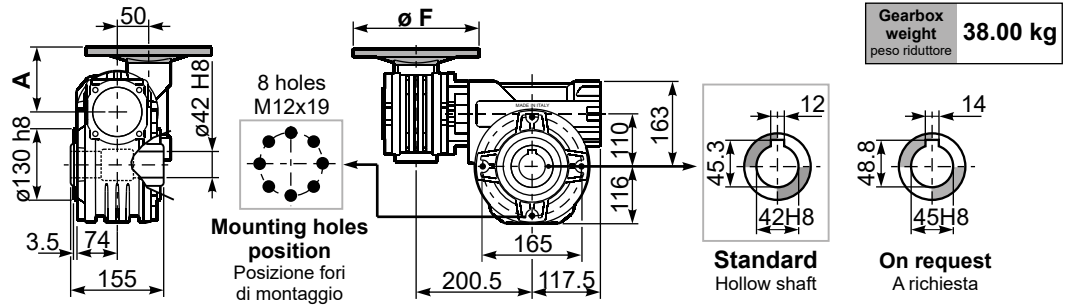

P115PA... Feet
Piedini

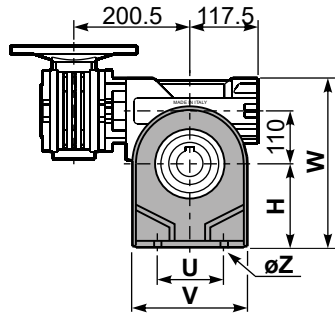
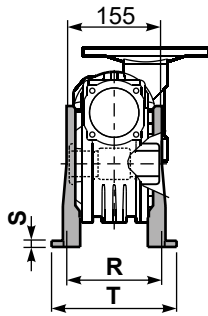

P115PB... Feet
Piedini

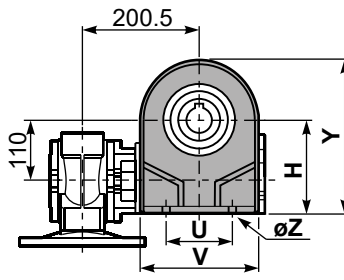

P115PV... Feet
Piedini

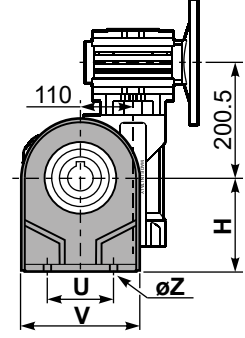

	H	R	S	T	U	V	Y	W	øZ	kit code
type B	170	180	8	224	200	240	286	333	ø13	K110.9.022
type S	-	-	-	-	-	-	-	-	-	-

P115FC... Output flange
Flangia uscita

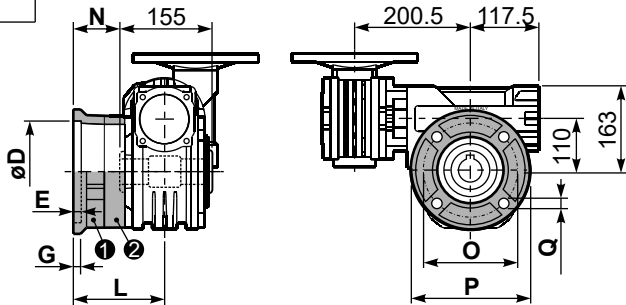

type B	øD	E	G	L	N	O	P	Q	kit code
FC	170 ^{+0.083} / _{+0.043}	11	16.5	131.5	54	230	270	13	① K110.9.010 ② -
FL	170 ^{+0.083} / _{+0.043}	11	16.5	179.5	102	230	270	13	① K110.9.011 ② -
type S	øD	E	G	L	N	O	P	Q	kit code
F1	180 ^{+0.040} / ₀	5	18	150	72.5	215	250	15	① KS110.9.014 ② -
F3	180 ^{+0.040} / ₀	5	18	130	52.5	215	250	15	① KS110.9.013 ② -

P115BR... Reaction arm
Braccio di reazione

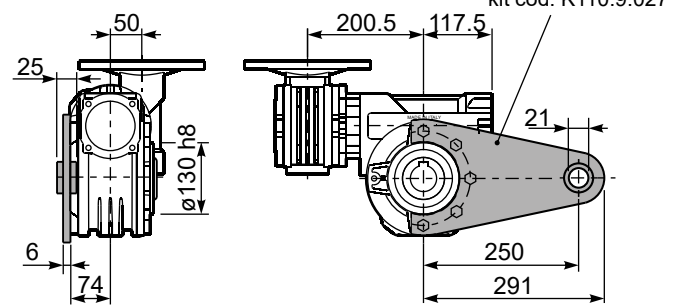

P115....S... Single Shaft
Albero lento semplice

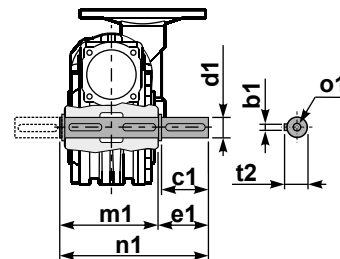

P115....D... Double Shaft
Albero lento bisp.

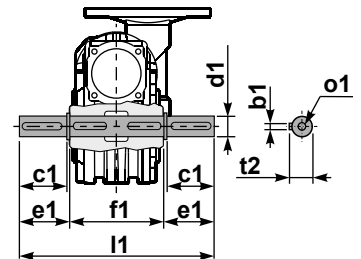

① kit cod. K110.5.028 type B

② kit cod. K110.5.029 type B

R115FB... Input shaft
Albero in entrata

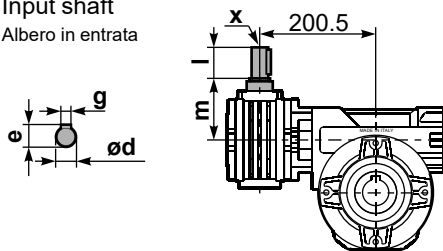

	ød	e	g	l	m	x	kit code
type B	16 h6	18	5	30	74.5	M6x16	① K050.5.006 PAM71 ② K050.5.007 PAM80
type S	14 h6	16	5	30	74.5	M5x10	① KS050.5.008 PAM71 ② KS050.5.009 PAM80

	b1	c1	d1	e1	f1	l1	m1	n1	t2	o1
type B	12	75	42 ^{-0.005} / _{-0.020}	96.5	155	348	163.5	260	45	M12x32
type S	-	-	-	-	-	-	-	-	-	-

M Square worm gearboxes

A modular and compact product

Single-piece aluminum alloy housing

Is vacuum impregnated (MIL-STD 276) for protection and sealing.

No secondary finish required but readily accepts paint. Combines light weight with high tensile strength. Precision machined for alignment of bearings and gearing.

Single piece alloy steel input shaft and worm shaft.

High helix angle worm is case-hardened (Rc 58-60), ground, teeth are profiled and radiused, for noise reduction and enhanced efficiency.

Oversized bearings

Support positively-retained, high speed shaft for higher shock load capacity - ideal for frequent starting and reversing application. Premium, Nitrile® high temperature seals each end.

Flange

Fully modular to IEC and compact integrated motor. NEMA C flange.

Premium, high temperature

Nitrile® output seals

Bronze alloy worm gears.

CuSn12Ni (C91700) Nickel bronze worm gears are centrifugally cast onto an iron hub for maximum strength and superior life. Removable hollow shaft with key for safe torque transmissions.

Over-size bearing

For radial load capability and maximum hollow output shaft diameter.

Standard hollow output shaft mounting

Reduces total drive envelope size, weight and cost. Single and double solid output shaft is available.

Impregnated and machined bearing caps

With exterior machined surfaces enable a variety of mounting accessories. Extra-deep thread engagement provided for greater support strength. Zinc plated hardware.

Painting

Cast iron gearboxes are painted RAL 7046

Vent Free Design.

No breather or vents to leak! Factory lubricated for life with synthetic, semi-fluid gear lubricant with an operating range of -15°C to 130°C.

oil free



vent free



Specific type datasheet on page...

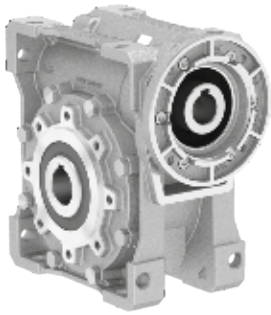

Types / Tipi /
Tipen / Types /
Tipos

On page / A pagina / Auf Seite / À la page / En la página

2-5	2-7	2-9	2-11	2-13	2-15	2-17	2-19	2-21
M30	M45	M50	M63	M75	M85	M11	M13	M15
21Nm	47Nm	88Nm	160Nm	270Nm	364Nm	725Nm	1050Nm	1550Nm

2

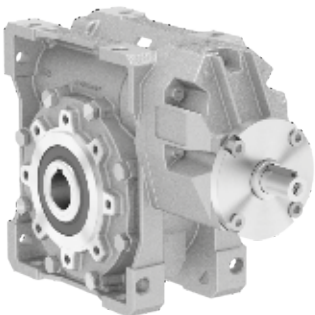

Types / Tipi /
Tipen / Types /
Tipos

On page / A pagina / Auf Seite / À la page / En la página

2-23	2-25	2-27	2-29	2-31	2-33
P4M	P5M	P6M	P7M	P8M	P1M
55Nm	88Nm	187Nm	310Nm	440Nm	803Nm

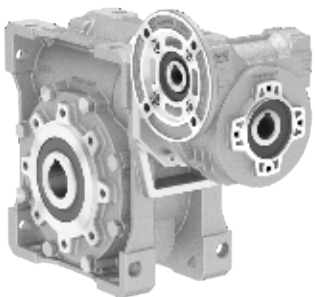

Types / Tipi /
Tipen / Types /
Tipos

On page / A pagina / Auf Seite / À la page / En la página

2-35	2-37	2-39	2-41	2-43	2-45	2-47	2-49
33M	43M	53M	63M	64M	74M	84M	15M
38Nm	72Nm	138Nm	270Nm	290Nm	420Nm	596Nm	1174Nm

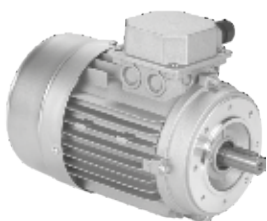

Types / Tipi
Tipen / Types
Tipos

On page / A pagina / Auf Seite / À la page / En la página

M-1										
56A	63A	71A	80A	90S	100LA	112M	132S	160M	180M	
56B	63B	71B	80B	90L	100LB		132M	160L	180L	

Type - Tipo - Typ
Type - Tipo

Size - Grandezza
Größe - Taille
Tamaño

Mounting - Montaggio - Montage Fixation
Fixation - Tipo de montaje

P

M45

FC

Worm gearboxes

Riduttori a vite senza fine
Schneckengetriebe
Reducteurs a vis sans fin
Reductores de corona sin fin

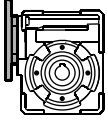

P

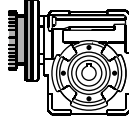

M

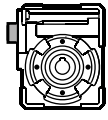

B

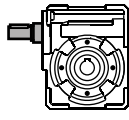

R

**M30
M45
M50
M63
M75
M85
M11
M13
M15**

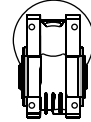

FB

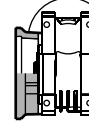

FC

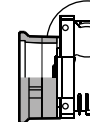

FL

**F1
F2
F3
F4**

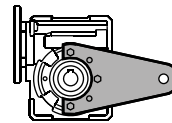

BR

Worm gearboxes with primary reduction

Riduttori a vite senza fine con precoppia
Schneckengetriebe mit Stirradstufe am Eintrieb
Reducteurs a vis sans fin avec pré-réduction
Reductores corona sin fin con prereducora de engrajes

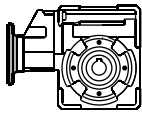

P

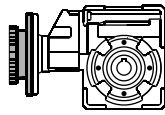

M

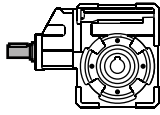

R

**P4M
P5M
P6M
P7M
P8M
P1M**

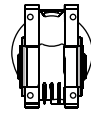

FB

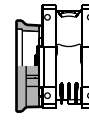

FC

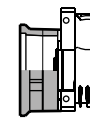

FL

**F1
F2
F3
F4**

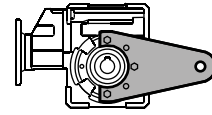

BR

Combined worm gearboxes

Riduttori a vite senza fine combinati
Schneckengetriebekombinationen
Reducteurs a double train de vis sans fin
Reductores combinados corona sin fin

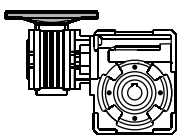

P

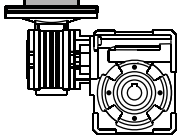

M

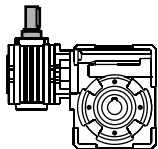

R

**33M
43M
53M
63M
64M
74M
84M
15M**

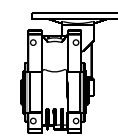

FB

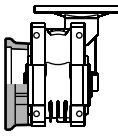

FC

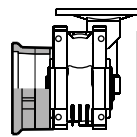

FL

**F1
F2
F3
F4**

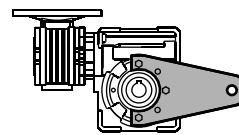







BR

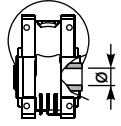
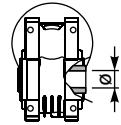
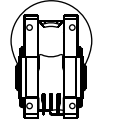
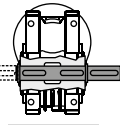
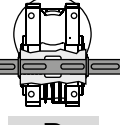
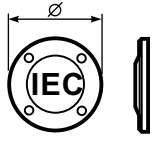
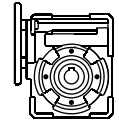
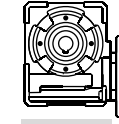
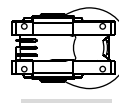
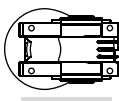
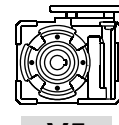
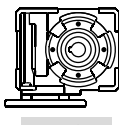
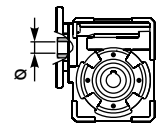
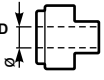
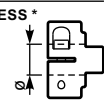

On request we can deliver our products according to the ATEX
A richiesta possiamo fornire i nostri prodotti secondo le normative ATEX
Auf Anfrage können wir unsere Produkte den Richtlinien ATEX entsprechend liefern
Sur demande nos produits peuvent se conformer à la réglementation ATEX
A pedido, se pueden enviar nuestros productos de acuerdo con las normas ATEX.

CODIFICA / HOW TO ORDER / TYPENBEZEICHNUNGEN / CODIFICATION / CODIFICACIÓN

Ratio Rapporto Untersetzung Reduction Relación	Hub Mozzo corona Hohlwelle Arbre creux Nucleo corona	Output shaft Albero lento Abtriebswelle Arbre de sortie Eje salida	Motor size Grandezza motore Motor Grösse Grandeur moteur Tamaño motor	Mounting position Posizione montaggio Einbaulage Position de montage Position de montaje	Input bore Foro entrata Eingangshohlwelle Trou d'entree Eje hueco de entrada	Mountin position Esecuzione montaggio Einbaulage Exécution de montage Posición de montaje	Terminal box position Posizione morsetteria Klemmkastenlage Position boîte a bornes Posición caja de bornes
10	C	∅	-Q	B3	ST	---	
See technical data table Vedi tabella dati tecnici. Technisches Datenblatt beachten Voir tableau données techniques Ver tabla datos técnicos	 STANDARD C M30 ⇨ ∅14 M45 ⇨ ∅18 M50 ⇨ ∅25 M63 ⇨ ∅25 M75 ⇨ ∅28 M85 ⇨ ∅35 M11 ⇨ ∅42 M13 ⇨ ∅45 M15 ⇨ ∅50 I Stainless steel hub Mozzo in acciaio Inox Edelstahlhohlwelle Moyeu en acier Inox Nucleo corona de acero Inox SPECIAL SERIES: SERIE SPECIALE: S M45 ⇨ ∅19 M50 ⇨ ∅24 X Stainless steel hub Mozzo in acciaio Inox Edelstahlhohlwelle Moyeu en acier Inox Nucleo corona de acero Inox  INCH U M45 ⇨ ∅0.750" M50 ⇨ ∅1.000" M63 ⇨ ∅1.125" M85 ⇨ ∅1.500" Z Stainless steel hub Mozzo in acciaio Inox Edelstahlhohlwelle Moyeu en acier Inox Nucleo corona de acero Inox	 ∅  S  D	 -M without flange Senza flangia B5 -A=56 (∅120) -B=63 (∅140) -C=71 (∅160) -D=80 (∅200) -E=90 (∅200) -F=100 (∅250) -G=132 (∅300) -H=160 (∅350) B14 -O=56 (∅80) -P=63 (∅90) -Q=71 (∅105) -R=80 (∅120) -T=90 (∅140) -U=100 (∅160) -V=132 (∅200) Brushless BA=40/63-M5 BB=50/70-M5 BC=60/75-M5 BD=70/90-M6 BE=80/100-M6 BF=95/115-M8 BG=110/145-M8 BH=130/165-M8 -0=Type R -S=Type R S series	 B3  B8  B6  B7  V5  V6	 ST Standard bore * Kit R standard Foro standard * Kit R standard Input bore without Reduction Bushing -O = 9mm -P = 11mm -Q = 14mm -R = 19mm -T = 24mm -U = 28mm -V = 38mm COUPLING STANDARD (IEC)  -A = 9mm -B = 11mm -C = 14mm -D = 19mm -E = 24mm -F = 28mm BRUSHLESS*  -1 = 9mm -2 = 11mm -3 = 14mm -4 = 19mm -5 = 22mm -6 = 24mm Ready for input coupling Predisposto per giunto  -0 Type B Tipo B  -0 Type R Tipo R	Only for combined units See technical data table Solo per i riduttori combinati Vedi tabella dati tecnici. Ausführungen für Getriebekombinationen it Uniquement pour combinés. Voir tableau données techniques Sólo para combinados ver tabla datos técnicos	With Type M specify terminal box position Con tipo M specificare posizione morsetteria  A  B STANDARD  C  D

POTENZA RICHIESTA / REQUIRED POWER / ERFORDERLICHE LEISTUNG / PUISSANCE NECESSAIRE / POTENCIA NECESARIA

Lifting / sollevamento / hubantriebe / levage / elevación	$P [KW] = \frac{M [Kg] \cdot g [9.81] \cdot v [m / s]}{1000}$
Rotation / rotazione / drehung / rotation / rotação	$P [KW] = \frac{M [Nm] \cdot n [rpm]}{9550}$
Linear movement / traslazione / linearbewegung / translation / translación	$P [KW] = \frac{F [N] \cdot v [m / s]}{1000}$

TORQUE / COPPIA / DREHMOMENT / COUPLE / PAR

	$M [Nm] = \frac{9550 \cdot P[KW]}{n [rpm]}$
	$M [lb in] = \frac{63030 \cdot P[HP]}{n [rpm]}$

RADIAL LOADS / CARICHI RADIALI / RADIALE - UND AXIALLASTEN / CHARGES RADIALES / CARGA RADIAL Y AXIAL

- Radial load generated by external transmissions keyed onto input and/or output shafts.
- Forza radiale generata da organi di trasmissione calettati sugli alberi di ingresso e/o uscita.
- Belastungen der Antriebs- bzw. Abtriebswellen durch von aussen eingebrachte Radiallasten.
- Charge radiale générée par la transmissions calés sur les entrées et / ou des arbres de sortie
- Cargas radiales, generada por transmisiones externas, aplicadas sobre los ejes de entrada y/o salida

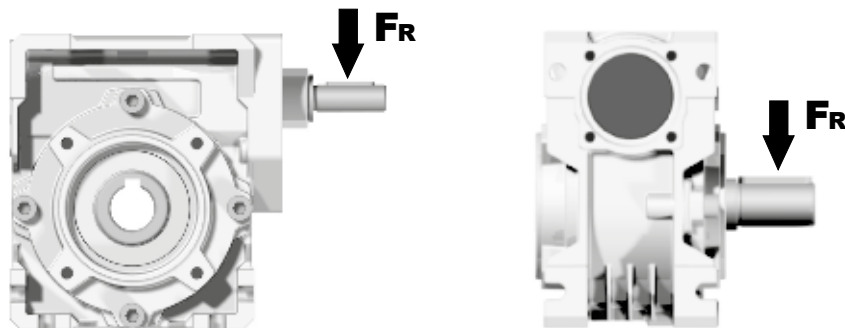

	$F_R [N] = \frac{M [Nm] \cdot 2000}{d [mm]} \cdot f_k$	$F_R [N] = \frac{M [lb in] \cdot 8.9}{d [in]} \cdot f_k$
M	Momento torcente / Output torque / Abtriebsdrehmoment / Couple / Par torsion	
d	Diametro primitivo / Diam. of driving element / Durchmesser der Abtriebseinheit / Diamètre primitif / Diámetro primitivo	
f_k	Coefficiente di trasformazione / Factor / Faktor / Coefficient de transmission / Coeficiente de transmisión 1.15 Ingranaggi / Gearwheels / Zahnrad / Engrenage / Engranaje 1.25 Catena / Chain sprockets / Antriebskette / Chaîne / Cadena 1.75 Cinghia Trapezoidale / Narrow v-belt pulley / Keilriemen / Courroie trap. / Correa trapezoidal 2.50 Cinghia piatta / Flat-belt pulley / Flachzahnriem. / Courroie crantée / Correa plana	

- If your application requires higher radial loads, contact our technical office. Higher load may be possible.
- Nel caso la vostra applicazione richieda carichi radiali superiori consultare il nostro ufficio tecnico, valori maggiori possono essere accettati.
- Wenn Ihre Anwendung höhere Radialbelastungen erfordert, so wenden Sie sich bitte an unser technischen Büro.
- Si votre application demande des charges radiales supérieures, s'adresser à notre bureau technique.
- En el caso en que una aplicación exija una carga radial superior a la especificada en el catálogo, consultar a nuestra oficinas técnica.

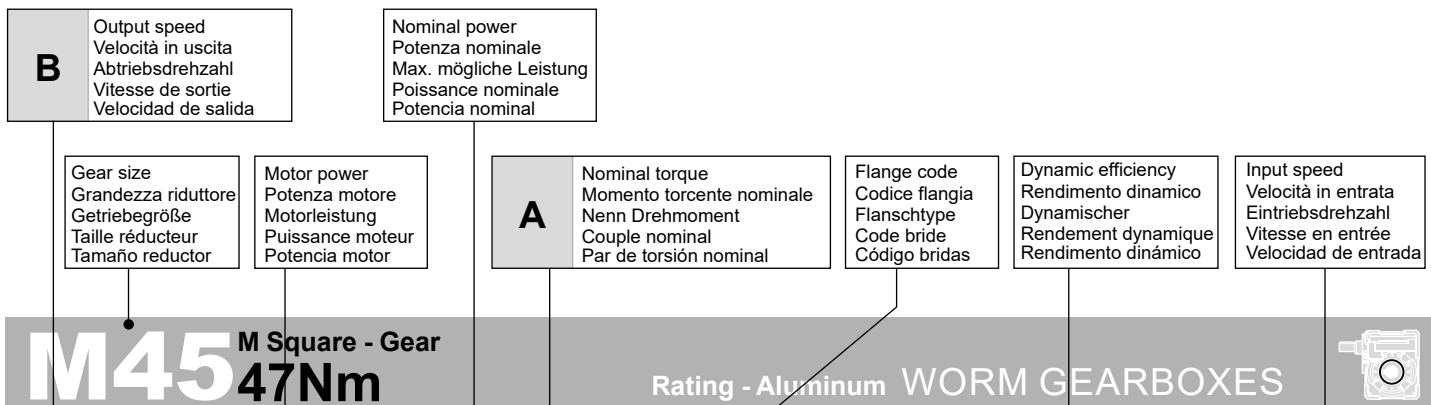

QUICK SELECTION / Selezione veloce

input speed (n₁) = 1400 min⁻¹

Output Speed n ₂ [min ⁻¹]	Ratio i	Motor power P _{1M} [kW]	Output torque M _{2M} [Nm]	Service factor f.s.	Nominal power P _{1R} [kW]	Nominal torque M _{2R} [Nm]	Available B5 motor flanges		Available B14 motor flanges			Dynamic efficiency RD	Tooth Module [mm]	Ratios code
							-B	-C	-O	-P	-Q			
200	7	0.37	14	2.9	1.07	41	B		B-C	B-C		80	2.2	01
140	10	0.37	20	2.2	0.82	44	B		B-C	B-C		79	2.2	02
100	14	0.37	27	1.6	0.60	44	B		B-C	B-C		77	2.4	03



fs		Oper. hours per day Ore di funz. giorn.		
Type of load and starts per hour Tipo di carico e avviamenti per ora		<2 h	2 - 8 h	8 - 16 h
Continuous or intermittent appl. with start / hour Applicazione cont. o interm. con n.ro operazioni/ora	Uniform / Uniforme	0.9	1	1.25
	Moderate / Moderato	1	1.25	1.5
	Heavy / Forte	1.25	1.5	1.75
Intermittent application with start / hour Applicazione intermittente con n.ro operazioni/ora	Uniform / Uniforme	1.25	1.5	1.75
	Moderate / Moderato	1.5	1.75	2
	Heavy / Forte	1.75	2	2.25

D	Motor flange available Flange disponibili Erhältliche Motorflansche Brides disponibles Bridas disponibles	
B)	Mounting with reduction ring Montaggio con boccolla di riduzione Reduzierhülsen Montage avec douille de réduction Montaje con casquillo de reducción	
C)	Motor flangeholes position/terminal box position Posizione fori flangia/basetta motore Bohrungsposition am Motorflansch/-sockel Position trous bride/barrette à bornes moteur Posición agujeros brida / base motor	
B)	Available without reduction bushes Disponibile anche senza boccolla Auch ohne Reduzierbuchse verfügbar Disponible aussi sans douille de réduction Disponible tambien sin casquillo	

A	Select required torque (according to service factor)	Seleziona la coppia desiderata (comprensiva del fattore di servizio)	Max. Drehmoment in Bezug zum Betriebsfaktor	Sélectionner le couple souhaité (comprenant le facteur de service)	Seleccionar el par deseado (incluyendo el factor de servicio)
B	Select output speed	Seleziona la velocità in uscita	Ausgewählte Abtriebsdrehzahl	Sélectionner la vitesse de sortie	Seleccionar la velocidad de salida
C	On the same line of selected geared motor, you can find the gear ratio	Sulla riga corrispondente alla motorizzazione prescelta si può rilevare il rapporto di riduzione	Auf der gleichen Linie wie die ausgewählte Motorleistung steht auch die Getriebeuntersetzung	Sur la ligne correspondante à la motorisation pré-choisie on peut relever le rapport de réduction	En la línea correspondiente al motor preseleccionado es posible encontrar la relación de reducción
D	Select motor flange available (if requested)	Scegli la flangia disponibile (se richiesta)	Erhältliche Motorflansche (auf Anfrage)	Choisir la bride disponible (si elle est demandée)	Seleccionar la brida disponible (sobre pedido)



QUICK SELECTION / Selezione veloce

input speed (n_1) = 1400 min⁻¹

Output Speed n_2 [min ⁻¹]	Ratio i	Motor power P_{1M} [kW]	Output torque M_{2M} [Nm]	Service factor f.s.	Nominal power P_{1R} [kW]	Nominal torque M_{2R} [Nm]	Available B5 motor flanges		Available B14 motor flanges		Dynamic efficiency RD	Tooth Module [mm]	 Ratios code
							-A	-B	-O	-P			
							56	63	56	63			
280	5	0.18	5	3.8	0.68	19	B		B-C		82	1.26	01
200	7	0.18	7	2.8	0.50	19	B		B-C		80	1.44	02
140	10	0.18	10	2.0	0.36	19	B		B-C		78	1.44	03
93	15	0.18	13	1.4	0.25	19	B		B-C		73	1.44	04
70	20	0.18	17	1.1	0.20	19	B		B-C		70	1.09	05
47	30	0.12	15	1.4	0.17	21	B		B-C		62	1.44	06
35	40	0.12	19	1.1	0.13	20	B		B-C		57	1.09	07
23	61	0.09	19	1.1	0.10	20	B		B-C		50	0.72	08
17.5	80	0.06	16	1.0	0.06	16	B		B-C		48	0.56	09
14	100	0.06*	16	0.5	0.03	8	B		B-C		40	0.45	10

A) Motor Flanges Available
Flange Motore Disponibili

B) Supplied with Reduction Bushing
Fornito con Bussola di Riduzione

B) Available on Request without reduction bushing
Disponibile a Richiesta senza Bussola di Riduzione

C) Motor Flange Holes Position
Posizione Fori Flangia Motore

* Power higher than the maximum one which can be supported by the gearbox. Select according to the torque M_{2R}
Potenza superiore a quella massima sopportabile dal riduttore. Selezionare in base al momento torcente M_{2R}

EN Unit **M30** is supplied with synthetic oil, providing "long life" lubrication. For mounting position V5-V6 please contact us. See table 1 for lubrication and recommended quantity. In table 2 please see possible radial loads and axial loads on the gearbox.

I Il riduttore tipo **M30** viene fornito lubrificato a vita con olio sintetico. Per posizioni V5-V6 contattare il ns. servizio tecnico. Vedi tab.1 per oli e quantità consigliati. In tab.2 sono presenti i carichi radiali e assiali applicabili al riduttore.

D Für die Lebensdauerschmierung ist das Getriebe der Größe **M30** mit synthetischem Öl befüllt. Bei Einbaulage V5 oder V6 bitten wir um Rücksprache. In Tabelle 1 ist die Schmiermenge und das empfohlene Schmiermittel angegeben. In Tabelle 2 sind die zulässigen Radial- und Axialbelastungen des Getriebes aufgeführt.

F Le réducteur de type **M30** est fourni lubrifié à vie avec de l'huile synthétique. Concernant les positions V5.V6, contactez notre service d'assistance technique. Voir tableau 1 concernant les huiles et les quantités conseillées. Les charges radiales et axiales applicables au réducteur sont précisées dans le tableau 2.

E El reductor tamaño **M30** se suministra, lubricado de por vida con aceite sintético. Para las posiciones V5 y V6 contactar con nuestro servicio técnico. Ver tabla 1, para cantidades y aceites recomendados. En la tabla 2, se encuentran las cargas radiales y axiales admitidas por el reductor.

LUBRICATION M30 Oil Quantity 0.03Lt.

SHELL Omala S4 WE 320

ENI Telium VSF 320

For all details on lubrication and plugs check our website **tab. 1**
Per maggiori dettagli su lubrificazione e tappi olio vedi il nostro sito web

RADIAL AND AXIAL LOADS

Output shaft

Albero di uscita

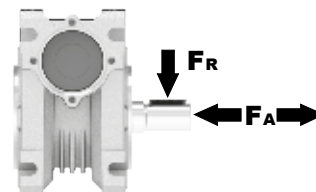

n_2 [min ⁻¹]	FA [N]	FR [N]
200	120	600
150	140	700
100	160	800
75	180	900
50	200	1000
25	250	1250
15	280	1400

Input shaft

albero in entrata

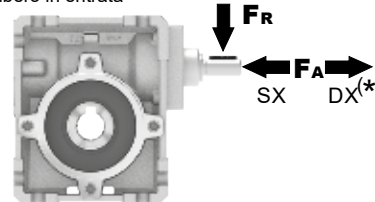

n_1 [min ⁻¹]	FA [N]	FR [N]
1400	20	100

*Strong axial loads in the DX direction are not allowed.
Non sono consentiti forti carichi assiali con direzione DX

tab. 2

PM30**FB**... Basic wormbox
Riduttore base

Gearbox weight
peso riduttore **1.15 kg**

M. flanges	Kit code	øF	A
56B5	K030.4.041	120	61.5
63B5	K030.4.042	140	62.5
56B14	K030.4.046	80	61.5
63B14	K030.4.045	90	62.5

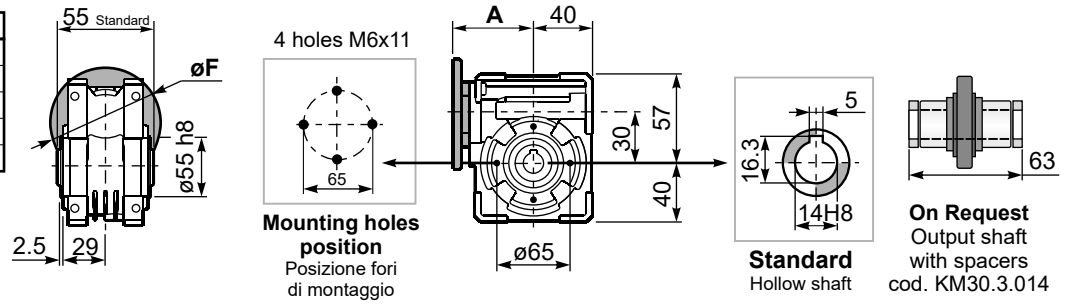

PM30**FC**... Square flange
Flangia quadrata

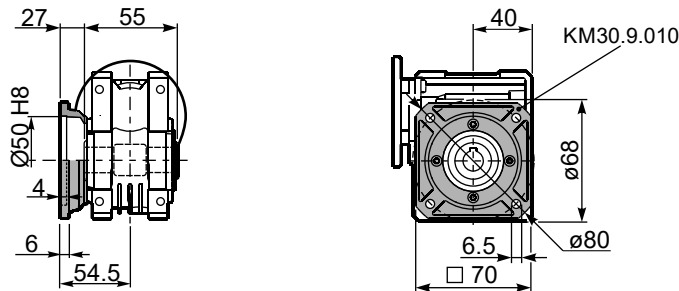

PM30**FB**... Feet
Piedini

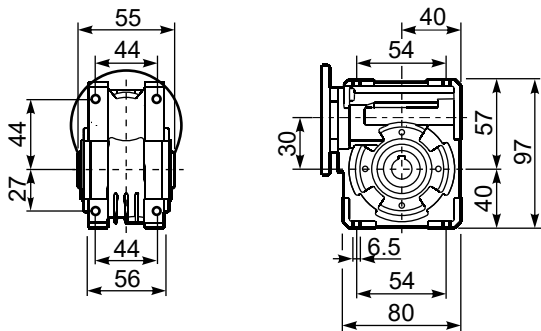

PM30**BR**... Reaction arm
Braccio di reazione

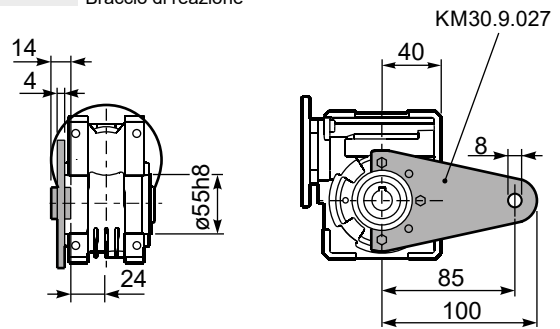

RM30FB... Input shaft
Albero in entrata

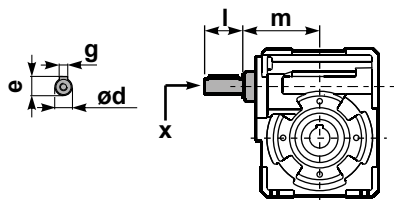

PM30....**S**... Single Shaft
Albero lento semplice

PM30....**D**... Double Shaft
Albero lento bisp.

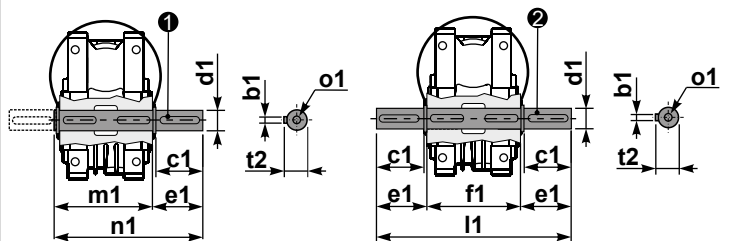

① kit cod. K030.5.028 type B

② kit cod. K030.5.029 type B

	ød	e	g	l	m	x	kit code
type B	9 h6	10.2	3	20	58	-	K030.5.006 PAM63
type S	-	-	-	-	-	-	-

	b1	c1	d1	e1	f1	l1	m1	n1	t2	o1
type B	5	25	14 ^{-0.005} _{-0.020}	35.5	55	126	59	94.5	16	M5x14
type S	-	-	-	-	-	-	-	-	-	-



QUICK SELECTION / Selezione veloce

input speed (n_1) = 1400 min⁻¹

Output Speed n_2 [min ⁻¹]	Ratio i	Motor power P_{1M} [kW]	Output torque M_{2M} [Nm]	Service factor f.s.	Nominal power P_{1R} [kW]	Nominal torque M_{2R} [Nm]	Available B5 motor flanges		Available B14 motor flanges			Dynamic efficiency RD	Tooth Module [mm]	Ratios code
							-B	-C	-O	-P	-Q			
							63	71	56	63	71			
200	7	0.37	14	2.9	1.07	41	B		B-C	B-C		80	2.2	01
140	10	0.37	20	2.2	0.82	44	B		B-C	B-C		79	2.2	02
100	14	0.37	27	1.6	0.60	44	B		B-C	B-C		77	2.4	03
67	21	0.37	36	1.2	0.44	42	B		B-C	B-C		67	1.6	04
50	28	0.37	46	1.0	0.38	47	B		B-C	B-C		65	2.5	05
38	37	0.25	40	1.0	0.26	41	B		B-C	B-C		63	1.8	06
30	46	0.25	46	0.9	0.22	41	B		B-C	B-C		59	1.5	07
23	60	0.18	41	1.0	0.18	41	B		B-C	B-C		56	1.2	08
20	70	0.12	31	1.0	0.12	30	B		B-C	B-C		54	1.0	09
13.7	102	0.09	31	0.9	0.09	29	B		B-C	B-C		49	0.72	10

A Motor Flanges Available
Flange Motore Disponibili

B Supplied with Reduction Bushing
Fornito con Bussola di Riduzione

B Available on Request without reduction bushing
Disponibile a Richiesta senza Bussola di Riduzione

C Motor Flange Holes Position
Posizione Fori Flangia Motore

* Power higher than the maximum one which can be supported by the gearbox. Select according to the torque M_{2R}
Potenza superiore a quella massima sopportabile dal riduttore. Selezionare in base al momento torcente M_{2R}

EN Unit **M45** is supplied with synthetic oil, providing "long life" lubrication. For mounting position V5-V6 please contact us. See table 1 for lubrication and recommended quantity. In table 2 please see possible radial loads and axial loads on the gearbox.

I Il riduttore tipo **M45** viene fornito lubrificato a vita con olio sintetico. Per posizioni V5-V6 contattare il ns. servizio tecnico. Vedi tab.1 per oli e quantità consigliati. In tab.2 sono presenti i carichi radiali e assiali applicabili al riduttore.

D Für die Lebensdauerschmierung ist das Getriebe der Größe **M45** mit synthetischem Öl befüllt. Bei Einbaulage V5 oder V6 bitten wir um Rücksprache. In Tabelle 1 ist die Schmiermenge und das empfohlene Schmiermittel angegeben. In Tabelle 2 sind die zulässigen Radial- und Axialbelastungen des Getriebes aufgeführt.

F Le réducteur de type **M45** est fourni lubrifié à vie avec de l'huile synthétique. Concernant les positions V5.V6, contactez notre service d'assistance technique. Voir tableau 1 concernant les huiles et les quantités conseillées. Les charges radiales et axiales applicables au réducteur sont précisées dans le tableau 2.

E El reductor tamaño **M45** se suministra, lubricado de por vida con aceite sintético. Para las posiciones V5 y V6 contactar con nuestro servicio técnico. Ver tabla 1, para cantidades y aceites recomendados. En la tabla 2, se encuentran las cargas radiales y axiales admitidas por el reductor.

LUBRICATION M45 Oil Quantity 0.09 Lt.

SHELL Omala S4 WE 320 **ENI** Telium VSF 320

For all details on lubrication and plugs check our website **tab. 1**
Per maggiori dettagli su lubrificazione e tappi olio vedi il nostro sito web

RADIAL AND AXIAL LOADS

Output shaft
Albero di uscita

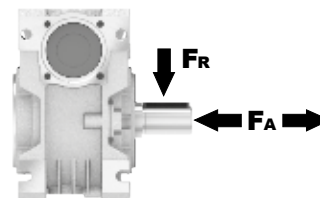

n_2 [min ⁻¹]	FA [N]	FR [N]
200	180	900
150	200	1000
100	220	1100
75	240	1200
50	260	1400
25	300	1800
15	400	2000

Input shaft
albero in entrata

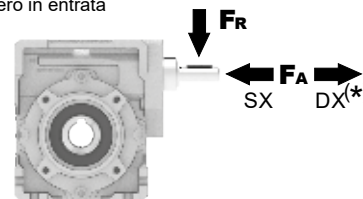

n_1 [min ⁻¹]	FA [N]	FR [N]
1400	42	210

*Strong axial loads in the DX direction are not allowed.
Non sono consentiti forti carichi assiali con direzione DX

tab. 2

PM45FB... Basic wormbox
Riduttore base

M. flanges	Kit code	øF	A
63B5	K050.4.041	138	80
71B5	K050.4.042	160	77.5
56B14	KC40.4.049	80	77.5
63B14	K050.4.047	90	80
71B14	K050.4.045	105	77.5

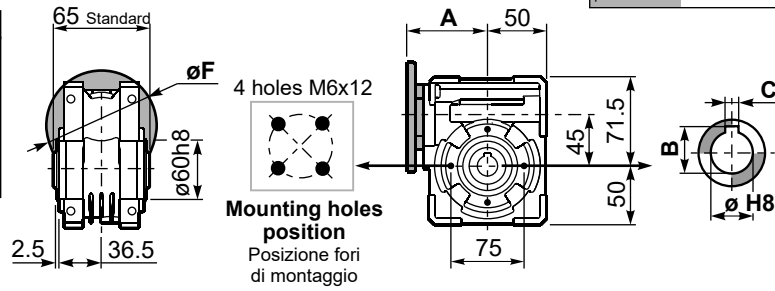

ø H8	B	C	*Spacer code
18 Standard	20.8	6	KM45.3.018
19 on request	21.8	6	KM45.3.019
20 on request	22.8	6	KM45.3.020

*On Request
output shaft with spacers

PM45FC... Square flange
Flangia quadrata

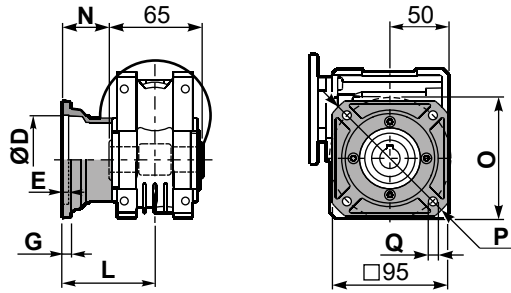

type B	øD	E	G	L	N	O	P	Q	kit code
FC	60 H8	4	7	67	34.5	75	110	9	KM45.9.010
FL	60 H8	4	7	97	64.5	75	110	9	KM45.9.011

PM45F1... Round flange
Flangia rotonda

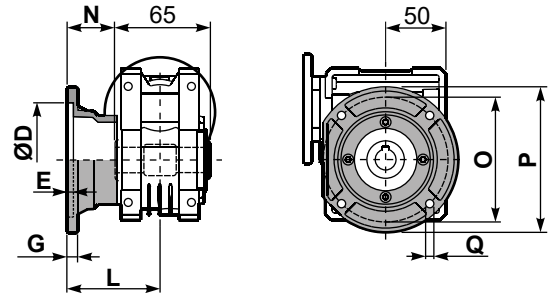

type S	øD	E	G	L	N	O	P	Q	kit code
F1	95H8	5	9	80	47.5	115	140	9.5	KM45.9.012
F2	-	-	-	-	-	-	-	-	-

PM45FB... Feet
Piedini

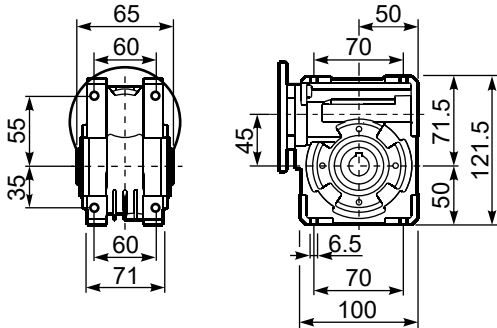

PM45BR... Reaction arm
Braccio di reazione

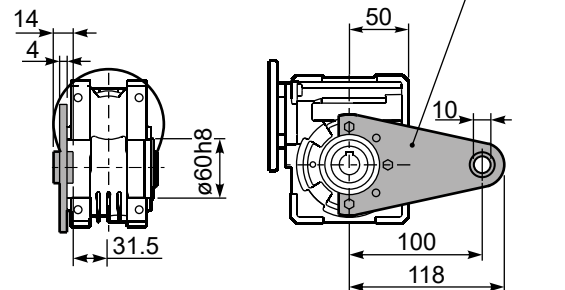

RM45FB... Input shaft
Albero in entrata

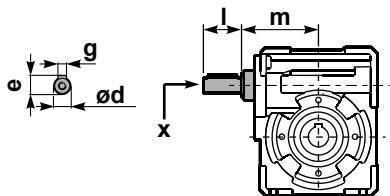

	ød	e	g	l	m	x	kit code
type B	11 h6	12.5	4	30	74	-	① K045.5.006 PAM71
type S	-	-	-	-	-	-	② -

PM45.....S... Single Shaft
Albero lento semplice

PM45.....D... Double Shaft
Albero lento bisp.

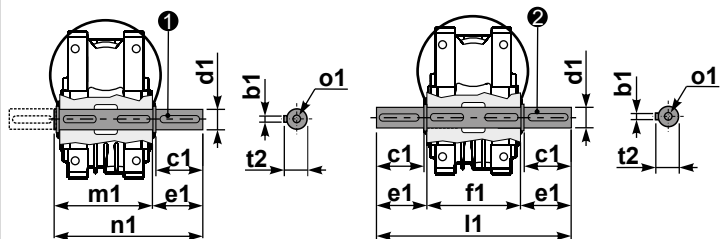

① kit cod. K045.5.028 type B
kit cod. KS045.5.030 type S

② kit cod. K045.5.029 type B

	b1	c1	d1	e1	f1	l1	m1	n1	t2	o1
type B	6	32	18 ^{-0.005} _{-0.020}	43	65	151	70	113	20.5	M6x18
type S	6	40	19 ^{-0.005} _{-0.020}	58.5	-	-	70	128.5	21.5	M8x20



QUICK SELECTION / Selezione veloce

input speed (n_1) = 1400 min⁻¹

Output Speed n_2 [min ⁻¹]	Ratio i	Motor power P_{1M} [kW]	Output torque M_{2M} [Nm]	Service factor f.s.	Nominal power P_{1R} [kW]	Nominal torque M_{2R} [Nm]	Available B5 motor flanges			Available B14 motor flanges				Dynamic efficiency RD	Tooth Module [mm]	Ratios code
							-B	-C	-D	-O	-P	-Q	-R			
							63	71	80	56	63	71	80			
200	7	0.75	29	2.6	1.92	75	B	B			B-C	B		82	2.5	01
140	10	0.75	41	1.9	1.43	78	B	B			B-C	B		80	2.4	02
100	14	0.75	57	1.4	1.05	79	B	B			B-C	B		79	2.6	03
78	18	0.75	69	1.1	0.81	75	B	B			B-C	B		75	2.0	04
54	26	0.55	67	1.1	0.58	71	B	B			B-C	B		69	2.7	05
47	30	0.55	79	1.1	0.61	88	B	B			B-C	B		70	2.5	12
39	36	0.37	63	1.3	0.48	82	B				B-C	B-C		69	2.1	06
33	43	0.37	72	1.1	0.42	82	B				B-C	B-C		66	1.8	07
28	50	0.37	78	1.0	0.36	76	B				B-C	B-C		62	1.5	13
23	60	0.25	59	1.2	0.30	71	B				B-C	B-C		58	1.3	08
21	68	0.25	66	1.0	0.25	66	B				B-C	B-C		57	1.2	09
17.5	80	0.18	53	1.2	0.22	65	B				B-C	B-C		54	1.0	10
14	100	0.12	41	1.3	0.16	55	B				B-C	B-C		50	0.8	11

A Motor Flanges Available
Flange Motore Disponibili

B Supplied with Reduction Bushing
Fornito con Bussola di Riduzione

B Available on Request without reduction bushing
Disponibile a Richiesta senza Bussola di Riduzione

C Motor Flange Holes Position
Posizione Fori Flangia Motore

EN Unit **M50** is supplied with synthetic oil, providing "long life" lubrication. For mounting position V5-V6 please contact us. See table 1 for lubrication and recommended quantity. In table 2 please see possible radial loads and axial loads on the gearbox.

I Il riduttore tipo **M50** viene fornito lubrificato a vita con olio sintetico. Per posizioni V5-V6 contattare il ns. servizio tecnico. Vedi tab.1 per oli e quantità consigliati. In tab.2 sono presenti i carichi radiali e assiali applicabili al riduttore.

D Für die Lebensdauerschmierung ist das Getriebe der Größe **M50** mit synthetischem Öl befüllt. Bei Einbaulage V5 oder V6 bitten wir um Rücksprache. In Tabelle 1 ist die Schmiermenge und das empfohlene Schmiermittel angegeben. In Tabelle 2 sind die zulässigen Radial- und Axialbelastungen des Getriebes aufgeführt.

F Le réducteur de type **M50** est fourni lubrifié à vie avec de l'huile synthétique. Concernant les positions V5.V6, contactez notre service d'assistance technique. Voir tableau 1 concernant les huiles et les quantités conseillées. Les charges radiales et axiales applicables au réducteur sont précisées dans le tableau 2.

E El reductor tamaño **M50** se suministra, lubricado de por vida con aceite sintético. Para las posiciones V5 y V6 contactar con nuestro servicio técnico. Ver tabla 1, para cantidades y aceites recomendados. En la tabla 2, se encuentran las cargas radiales y axiales admitidas por el reductor.

LUBRICATION M50 Oil Quantity 0.14 Lt.

SHELL Omala S4 WE 320

ENI Telium VSF 320

For all details on lubrication and plugs check our website **tab. 1**
Per maggiori dettagli su lubrificazione e tappi olio vedi il nostro sito web

RADIAL AND AXIAL LOADS

Output shaft

Albero di uscita

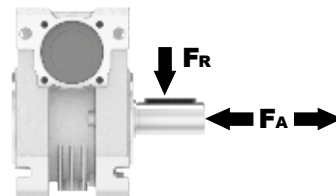

n_2 [min ⁻¹]	FA [N]	FR [N]
200	240	1200
150	280	1400
100	300	1500
75	340	1700
50	380	1900
25	480	2500
15	560	2800

Input shaft

albero in entrata

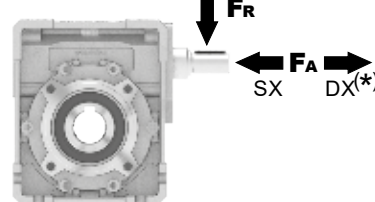

n_1 [min ⁻¹]	FA [N]	FR [N]
1400	76	380

***Strong axial loads in the DX direction are not allowed.**
Non sono consentiti forti carichi assiali con direzione DX

tab. 2

PM50**FB**... Basic wormbox
Riduttore base

Gearbox weight
peso riduttore **3.25 kg**

ø H8	B	C	*Spacer code
25 Standard	28.3	8	KM50.3.025
24 on request	27.3	8	KM50.3.024

M. flanges	Kit code	øF	A
63B5	K050.4.041	138	83.5
71B5	K050.4.042	160	81
80B5	K050.4.043	200	81.5
56B14	KC40.4.049	80	81
63B14	K050.4.047	90	83.5
71B14	K050.4.045	105	81
80B14	K050.4.046	120	81.5

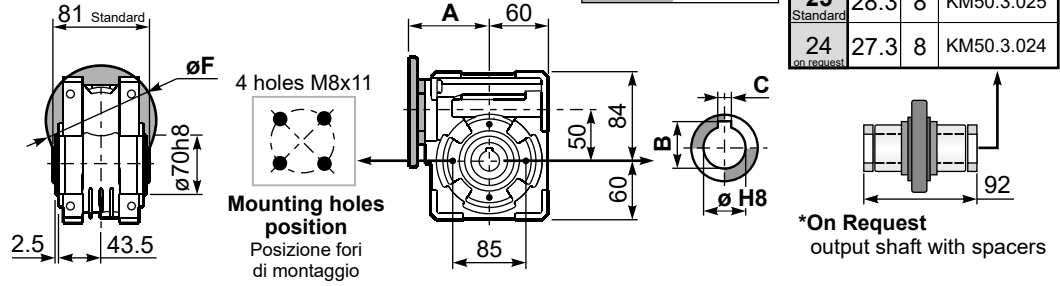

PM50**FC**... Square flange
Flangia quadrata

PM50**F1**... Round flange
Flangia rotonda

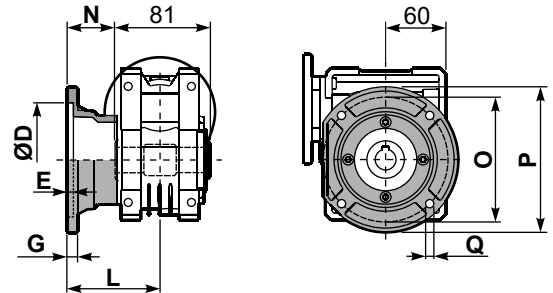
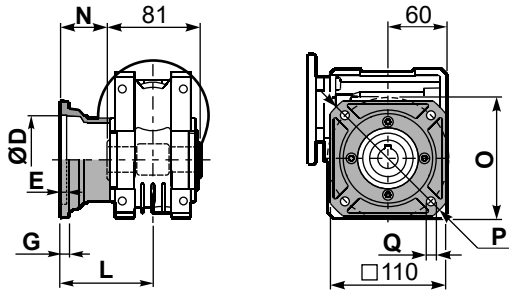

type B	øD	E	G	L	N	O	P	Q	kit code
FC	70 H8	5	9	90	49.5	85	125	11	KM50.9.010
FL	70 H8	5	9	120	79.5	85	125	11	KM50.9.011

type S	øD	E	G	L	N	O	P	Q	kit code
F1	110 H8	5	10	89	48.5	130	160	9.5	KM50.9.012
F2	95 H8	5	14.5	72	31.5	115	140	11	KM50.9.013

PM50**FB**... Feet
Piedini

PM50**BR**... Reaction arm
Braccio di reazione

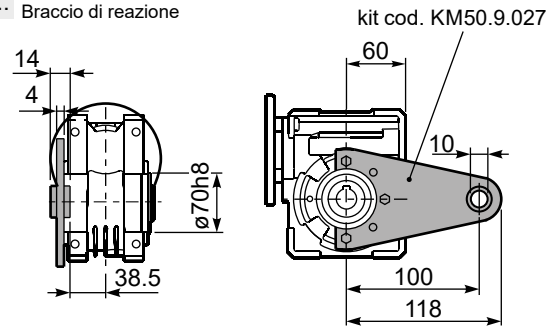
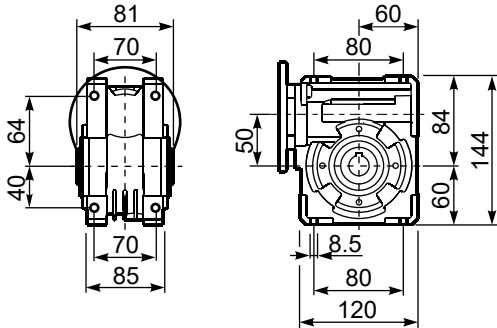

RM50**FB**... Input shaft
Albero in entrata

PM50.....**S**... Single Shaft
Albero lento semplice

PM50.....**D**... Double Shaft
Albero lento bisp.

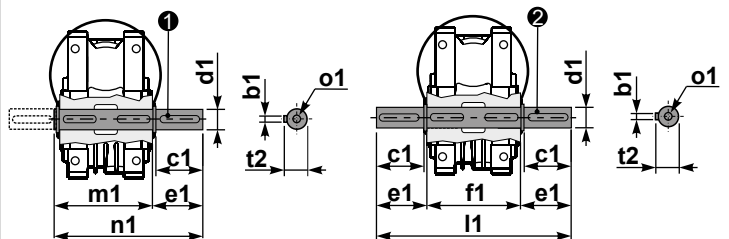
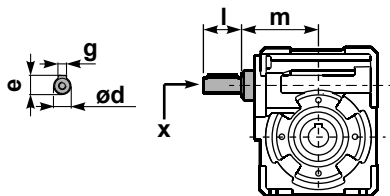

① kit cod. K050.5.028 type B
kit cod. KS050.5.030 type S
② kit cod. K050.5.029 type B

	ød	e	g	l	m	x	kit code
type B	16 h6	18	5	30	79.5	M6x16	① K050.5.006 PAM71 ② K050.5.007 PAM80
type S	14 h6	16	5	30	79.5	M5x10	① KS050.5.008 PAM71 ② KS050.5.009 PAM80

	b1	c1	d1	e1	f1	l1	m1	n1	t2	o1
type B	8	52	25 ^{-0.005} _{-0.020}	59.5	81	200	86.5	146	28	M8x20
type S	8	50	24 ^{-0.005} _{-0.020}	68.8	-	-	86.5	155	27	M8x20



QUICK SELECTION / Selezione veloce

input speed (n_1) = 1400 min⁻¹

Output Speed n_2 [min ⁻¹]	Ratio i	Motor power P_{1M} [kW]	Output torque M_{2M} [Nm]	Service factor f.s.	Nominal power P_{1R} [kW]	Nominal torque M_{2R} [Nm]	Available B5 motor flanges				Available B14 motor flanges			Dynamic efficiency RD	Tooth Module [mm]	Ratios code 	
							-B	-C	-D	-E	-Q	-R	-T				
							63	71	80	90	71	80	90				
200	7	1.8	71	1.8	3.2	128		B	B			B-C	B-C		83	3.1	01
140	10	1.8	99	1.3	2.4	134		B	B			B-C	B-C		81	3.1	02
93	15	1.5	121	1.2	1.8	148		B	B			B-C	B-C		79	3.1	03
74	19	1.5	152	1.0	1.4	145		B	B			B-C	B-C		78	2.6	04
58	24	1.1	135	1.1	1.2	142		B	B			B-C	B-C		75	2.0	05
47	30	1.1	167	1.0	1.06	160		B	B			B-C	B-C		74	3.2	06
39	36	0.75	125	1.2	0.88	147		B	B			B-C	B-C		68	2.7	07
35	40	0.75	135	1.1	0.82	148		B	B			B-C	B-C		66	2.5	13
31	45	0.55	111	1.2	0.67	135	B	B				B-C	C		66	2.1	08
23	60	0.55	140	1.0	0.53	135	B	B				B-C	C		62	1.6	12
21	67	0.55	151	0.8	0.45	124	B	B				B-C	C		60	1.5	09
17.5	80	0.37	115	1.1	0.39	122	B	B				B-C	C		57	1.3	10
14.9	94	0.37	123	1.0	0.36	119	B	B				B-C	C		52	1.1	11

A Motor Flanges Available
Flange Motore Disponibili

B Supplied with Reduction Bushing
Fornito con Bussola di Riduzione

B Available on Request without reduction bushing
Disponibile a Richiesta senza Bussola di Riduzione

C Motor Flange Holes Position
Posizione Fori Flangia Motore

EN Unit **M63** is supplied with synthetic oil, providing "long life" lubrication. For mounting position V5-V6 please contact us. See table 1 for lubrication and recommended quantity. In table 2 please see possible radial loads and axial loads on the gearbox.

I Il riduttore tipo **M63** viene fornito lubrificato a vita con olio sintetico. Per posizioni V5-V6 contattare il ns. servizio tecnico. Vedi tab.1 per oli e quantità consigliati. In tab.2 sono presenti i carichi radiali e assiali applicabili al riduttore.

D Für die Lebensdauerschmierung ist das Getriebe der Größe **M63** mit synthetischem Öl befüllt. Bei Einbaulage V5 oder V6 bitten wir um Rücksprache. In Tabelle 1 ist die Schmiermenge und das empfohlene Schmiermittel angegeben. In Tabelle 2 sind die zulässigen Radial - und Axialbelastungen des Getriebes aufgeführt.

F Le réducteur de type **M63** est fourni lubrifié à vie avec de l'huile synthétique. Concernant les positions V5.V6, contactez notre service d'assistance technique. Voir tableau 1 concernant les huiles et les quantités conseillées. Les charges radiales et axiales applicables au réducteur sont précisées dans le tableau 2.

E El reductor tamaño **M63** se suministra, lubricado de por vida con aceite sintético. Para las posiciones V5 y V6 contactar con nuestro servicio técnico. Ver tabla 1, para cantidades y aceites recomendados. En la tabla 2, se encuentran las cargas radiales y axiales admitidas por el reductor.

LUBRICATION M63 Oil Quantity 0.30 Lt.

SHELL Omala S4 WE 320

ENI Telium VSF 320

For all details on lubrication and plugs check our website **tab. 1**
Per maggiori dettagli su lubrificazione e tappi olio vedi il nostro sito web

RADIAL AND AXIAL LOADS

Output shaft

Albero di uscita

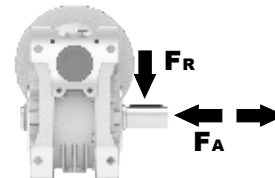

n_2 [min ⁻¹]	F_A [N]	F_R [N]
200	360	1800
150	400	2000
100	460	2300
75	500	2500
50	600	3000
25	700	3800
15	800	4000

Input shaft

albero in entrata

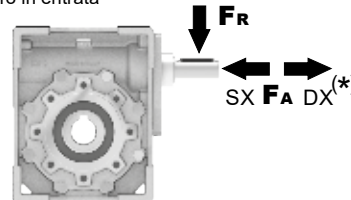

n_1 [min ⁻¹]	F_A [N]	F_R [N]
1400	90	450

***Strong axial loads in the DX direction are not allowed.**
Non sono consentiti forti carichi assiali con direzione DX

tab. 2

PM63**FB**... Basic wormbox
Riduttore base

Gearbox weight
peso riduttore **6.00 kg**

M. flanges	Kit code	øF	A
63B5	K063.4.041	140	100.5
71B5	K063.4.042	160	98.5
80/90B5	K063.4.043	200	100.5
71B14	K063.4.047	105	98.5
80B14	K063.4.046	120	100.5
90B14	K063.4.041	140	100.5

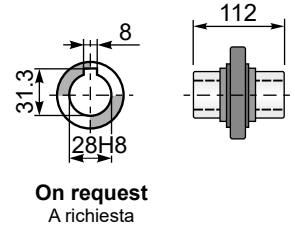
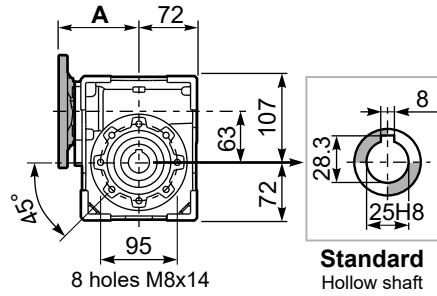
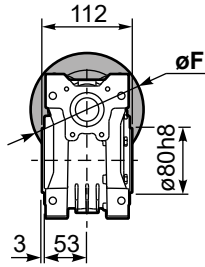

PM63**FC**... Square flange
Flangia quadrata

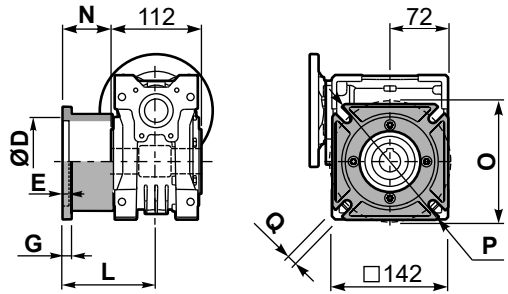

type B	øD	E	G	L	N	O	P	Q	kit code
FC	115 H8	6	10	82	26	150	180	11	KM63.9.010
FL	115 H8	6	10	112	56	150	180	11	KM63.9.011

PM63**F1**... Round flange
Flangia rotonda

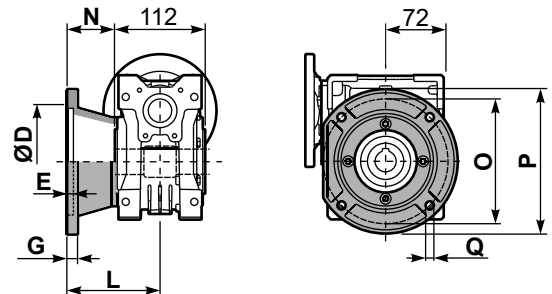

type S	øD	E	G	L	N	O	P	Q	kit code
F1	130 H8	5	10	98	42	165	200	11	KM63.9.012
F2	130 H8	5	10	107	51	165	200	11	KM63.9.013
F3	110 H8	5	16.5	80.5	24.5	130	160	11	KM63.9.014

PM63**FB**... Feet
Piedini

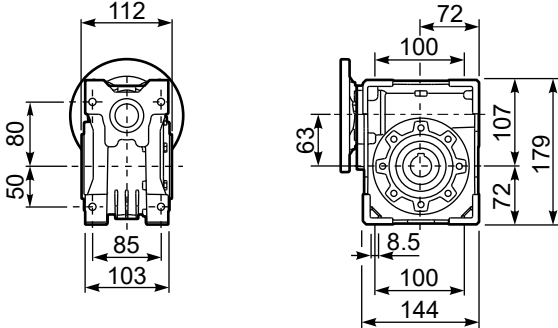

PM63**BR**... Reaction arm
Braccio di reazione

kit cod. KM63.9.027

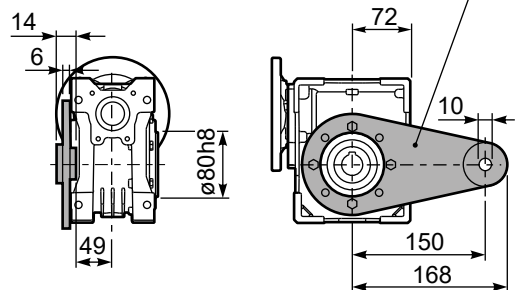

RM63FB... Input shaft
Albero in entrata

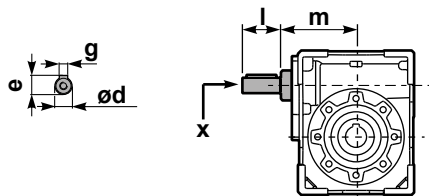

	ød	e	g	l	m	x	kit code
type B	18 h6	20.5	6	45	94	M6x16	① K063.5.006 PAM80 ② K063.5.007 PAM90
type S	19 h6	21.5	6	40	94	M8x20	① KS063.5.008 PAM80 ② KS063.5.009 PAM90

PM63.....**S**... Single Shaft
Albero lento semplice

PM63.....**D**... Double Shaft
Albero lento bisp.

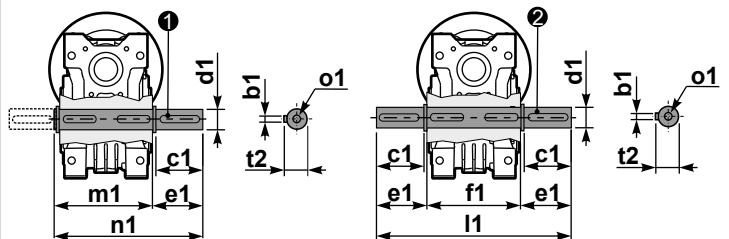

① kit cod. KM63.5.028 type B ② kit cod. KM63.5.029 type B

	b1	c1	d1	e1	f1	l1	m1	n1	t2	o1
type B	8	50	25 h6	53.5	112	219	119.5	173	28	M10x23
type S	-	-	-	-	-	-	-	-	-	-



QUICK SELECTION / Selezione veloce

input speed (n_1) = 1400 min⁻¹

Output Speed n_2 [min ⁻¹]	Ratio i	Motor power P_{1M} [kW]	Output torque M_{2M} [Nm]	Service factor f.s.	Nominal power P_{1R} [kW]	Nominal torque M_{2R} [Nm]	Available B5 motor flanges				Available B14 motor flanges			Dynamic efficiency RD	Tooth Module [mm]	Ratios code	
							-C	-D	-E	-F	-R	-T	-U				
							71	80	90	100	80	90	100				112
200	7	4	172	1.1	4.4	190		B	B			B	B		90	3.75	01
140	10	4	240	1.0	3.8	230		B	B			B	B		88	3.75	02
93	15	3	261	1.0	2.9	250		B	B			B	B		85	3.75	03
70	20	2.2	249	1.0	2.2	250		B	B			B	B		83	3.00	04
56	25	1.5	205	1.2	1.8	250	B	B				B			80	2.41	05
45	31	1.5	244	1.1	1.7	270	B	B				B			77	3.75	06
35	40	1.5	295	0.9	1.3	255	B	B				B			72	3.10	07
28	50	0.75	174	1.3	0.96	223	B								68	2.41	08
23	60	0.75	200	1.1	0.80	213	B								65	2.10	09
17.5	80	0.55	177	1.1	0.61	195	B								59	1.53	10
14.0	100	0.55	206	0.8	0.47	175	B								55	1.23	11

A Motor Flanges Available
Flange Motore Disponibili

B Supplied with Reduction Bushing
Fornito con Bussola di Riduzione

B Available on Request without reduction bushing
Disponibile a Richiesta senza Bussola di Riduzione

C Motor Flange Holes Position
Posizione Fori Flangia Motore

EN Unit M75 is supplied with synthetic oil, providing "long life" lubrication. For mounting position V5-V6 please contact us. See table 1 for lubrication and recommended quantity. In table 2 please see possible radial loads and axial loads on the gearbox.

I Il riduttore tipo M75 viene fornito lubrificato a vita con olio sintetico. Per posizioni V5-V6 contattare il ns. servizio tecnico. Vedi tab.1 per oli e quantità consigliati. In tab.2 sono presenti i carichi radiali e assiali applicabili al riduttore.

D Für die Lebensdauerschmierung ist das Getriebe der Größe M75 mit synthetischem Öl befüllt. Bei Einbaulage V5 oder V6 bitten wir um Rücksprache. In Tabelle 1 ist die Schmiermenge und das empfohlene Schmiermittel angegeben. In Tabelle 2 sind die zulässigen Radial- und Axialbelastungen des Getriebes aufgeführt.

F Le réducteur de type M75 est fourni lubrifié à vie avec de l'huile synthétique. Concernant les positions V5.V6, contactez notre service d'assistance technique. Voir tableau 1 concernant les huiles et les quantités conseillées. Les charges radiales et axiales applicables au réducteur sont précisées dans le tableau 2.

E El reductor tamaño M75 se suministra, lubricado de por vida con aceite sintético. Para las posiciones V5 y V6 contactar con nuestro servicio técnico. Ver tabla 1, para cantidades y aceites recomendados. En la tabla 2, se encuentran las cargas radiales y axiales admitidas por el reductor.

LUBRICATION M75 Oil Quantity 0.40 Lt.

SHELL Omala S4 WE 320

ENI Telium VSF 320

For all details on lubrication and plugs check our website **tab. 1**
Per maggiori dettagli su lubrificazione e tappi olio vedi il nostro sito web

RADIAL AND AXIAL LOADS

Output shaft
Albero di uscita

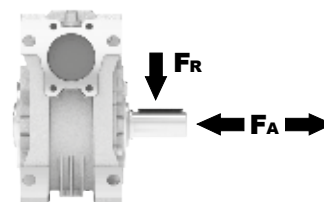

n_2 [min ⁻¹]	FA [N]	FR [N]
200	460	2300
150	520	2600
100	560	2800
75	620	3100
50	720	3600
25	880	4400
15	1000	5000

Input shaft
albero in entrata

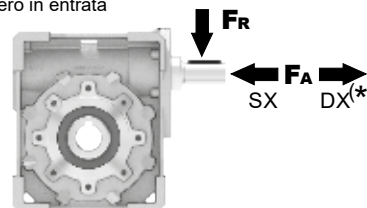

n_1 [min ⁻¹]	FA [N]	FR [N]
1400	125	630

*Strong axial loads in the DX direction are not allowed.
Non sono consentiti forti carichi assiali con direzione DX

tab. 2

PM75**FB**... Basic wormbox
Riduttore base

Gearbox weight
peso riduttore **8.70 kg**

M. flanges	Kit code	øF	A
71B5	K023.4.041	160	114
80/90B5	K023.4.042	200	116
100/112B5	K023.4.043	250	125
80B14	K085.4.046	120	116
90B14	K085.4.045	140	116
100/112B14	K085.4.047	160	125

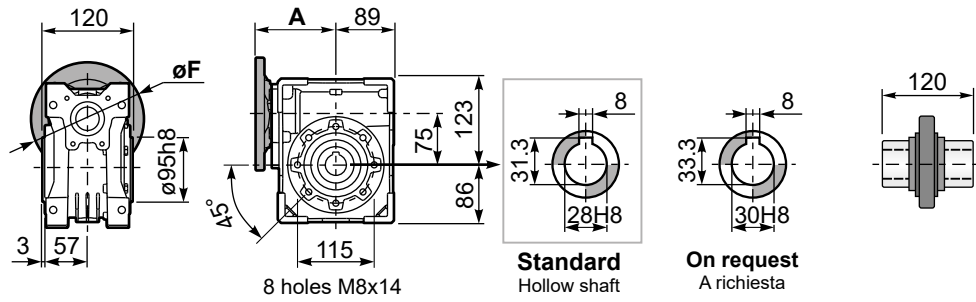

PM75**FC**... Round flange
Flangia rotonda

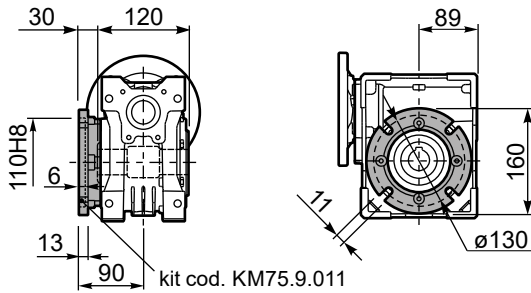

PM75**FL**... Square flange
Flangia quadrata

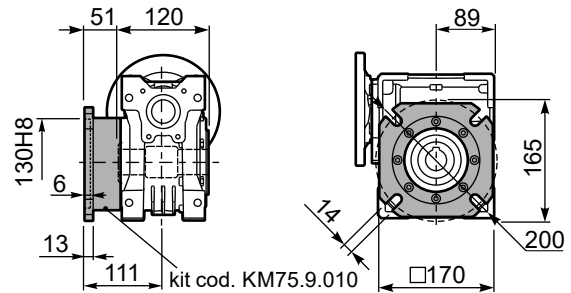

PM75**FB**... Feet
Piedini

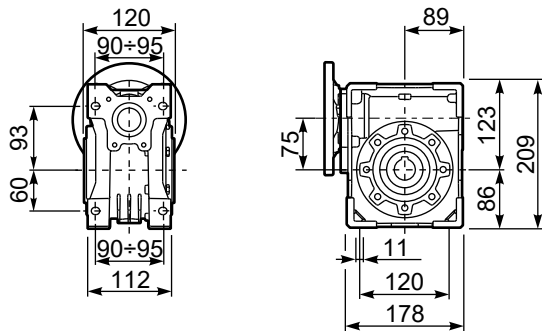

PM75**BR**... Reaction arm
Braccio di reazione

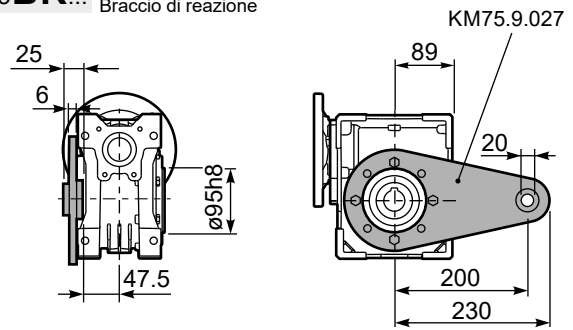

RM75FB... Input shaft
Albero in entrata

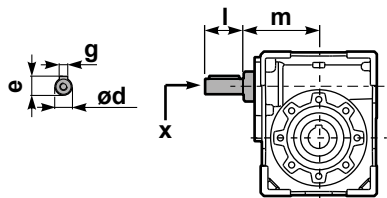

PM75...**S**... Single Shaft
Albero lento semplice

PM75...**D**... Double Shaft
Albero lento bisp.

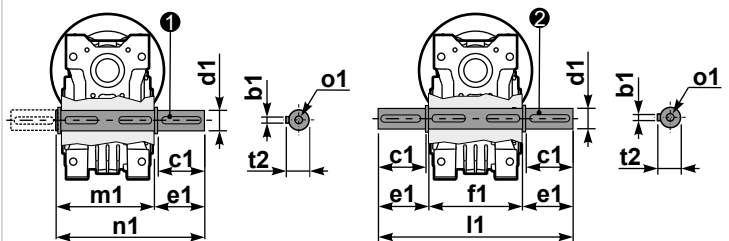

① kit cod. KM75.5.028 Standard

② kit cod. KM75.5.029 Standard

	ød	e	g	l	m	x	kit code
type B	25 h6	27.8	8	50	109.5	M8x20	KQ75.5.006 PAM80 K085.5.007 PAM90 K085.5.008 PAM100

	b1	c1	d1	e1	f1	l1	m1	n1	t2	o1
Standard	8	60	28 h6	63.5	120	247	128.5	192	31	M10
On request	-	-	-	-	-	-	-	-	-	-



QUICK SELECTION / Selezione veloce

input speed (n_1) = 1400 min⁻¹

Output Speed n_2 [min ⁻¹]	Ratio i	Motor power P_{1M} [kW]	Output torque M_{2M} [Nm]	Service factor f.s.	Nominal power P_{1R} [kW]	Nominal torque M_{2R} [Nm]	Available B5 motor flanges				Available B14 motor flanges			Dynamic efficiency RD	Tooth Module [mm]	Ratios code	
							-C	-D	-E	-F	-R	-T	-U				
							71	80	90	100 112	80	90	100 112				
200	7	4.0	168	1.6	6.4	270		B	B			B	B		88	4.23	01
140	10	4.0	218	1.4	5.5	298		B	B			B	B		80	4.2	02
100	14	4.0	298	1.1	4.3	320		B	B			B	B		78	4.5	03
70	20	3.0	323	1.0	2.9	309		B	B			B	B		79	3.4	04
64	22	2.2	258	1.2	2.6	309		B	B			B	B		78	3.1	05
50	28	2.2	315	1.2	2.5	364		B	B	B		B	B		75	4.7	06
37	38	1.5	276	1.3	1.9	353	B	B				B	B		71	3.5	07
30	46	1.5	320	1.1	1.6	342	B	B				B	B		68	3.1	08
27	52	1.1	258	1.2	1.3	303	B	B				B	B		66	2.7	09
21	67	1.1	327	0.9	1.02	303	B	B				B	B		65	2.1	10
18.9	74	0.75	220	1.3	0.96	281	B	B				B	B		58	1.9	11
14.6	96	0.55	191	1.3	0.73	254	B	B				B	B		53	1.5	12

Motor Flanges Available
Flange Motore Disponibili

B) Supplied with Reduction Bushing
Fornito con Bussola di Riduzione

B) Available on Request without reduction bushing
Disponibile a Richiesta senza Bussola di Riduzione

C) Motor Flange Holes Position
Posizione Fori Flangia Motore

EN Unit M85 is supplied with synthetic oil, providing "long life" lubrication. For mounting position V5-V6 please contact us. See table 1 for lubrication and recommended quantity. In table 2 please see possible radial loads and axial loads on the gearbox.

I Il riduttore tipo M85 viene fornito lubrificato a vita con olio sintetico. Per posizioni V5-V6 contattare il ns. servizio tecnico. Vedi tab.1 per oli e quantità consigliati. In tab.2 sono presenti i carichi radiali e assiali applicabili al riduttore.

D Für die Lebensdauerschmierung ist das Getriebe der Größe M85 mit synthetischem Öl befüllt. Bei Einbaulage V5 oder V6 bitten wir um Rücksprache. In Tabelle 1 ist die Schmiermenge und das empfohlene Schmiermittel angegeben. In Tabelle 2 sind die zulässigen Radial- und Axialbelastungen des Getriebes aufgeführt.

F Le réducteur de type M85 est fourni lubrifié à vie avec de l'huile synthétique. Concernant les positions V5.V6, contactez notre service d'assistance technique. Voir tableau 1 concernant les huiles et les quantités conseillées. Les charges radiales et axiales applicables au réducteur sont précisées dans le tableau 2.

E El reductor tamaño M85 se suministra, lubricado de por vida con aceite sintético. Para las posiciones V5 y V6 contactar con nuestro servicio técnico. Ver tabla 1, para cantidades y aceites recomendados. En la tabla 2, se encuentran las cargas radiales y axiales admitidas por el reductor.

LUBRICATION M85 Oil Quantity 1.20 Lt.

SHELL Omala S4 WE 320

ENI Telium VSF 320

For all details on lubrication and plugs check our website **tab. 1**
Per maggiori dettagli su lubrificazione e tappi olio vedi il nostro sito web

RADIAL AND AXIAL LOADS

Output shaft

Albero di uscita

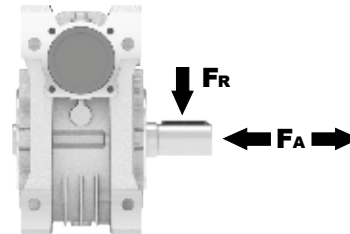

n_2 [min ⁻¹]	FA [N]	FR [N]
200	500	2500
150	580	2900
100	600	3000
75	700	3500
50	800	4000
25	1000	5000
15	1160	5800

Input shaft

albero in entrata

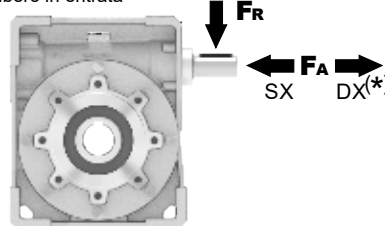

n_1 [min ⁻¹]	FA [N]	FR [N]
1400	130	650

*Strong axial loads in the DX direction are not allowed.
Non sono consentiti forti carichi assiali con direzione DX

tab. 2

PM85**FB**... Basic wormbox
Riduttore base

M. flanges	Kit code	øF	A
71B5	K023.4.041	160	116.5
80/90B5	K023.4.042	200	118.5
100/112B5	K023.4.043	250	127.5
80B14	K085.4.046	120	118.5
90B14	K085.4.045	140	118.5
100/112B14	K085.4.047	160	127.5

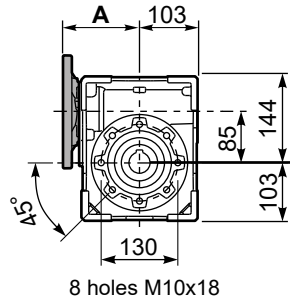
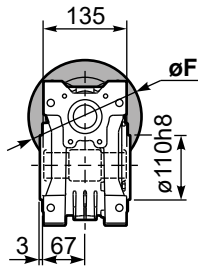

Gearbox weight
peso riduttore **12.1 kg**

ø H8	B	C	*Spacer code
35 Standard	38.3	10	KM85.3.035
38 on request	41.3	10	KM85.3.038

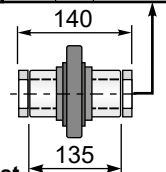

*On Request
output shaft with spacers

PM85**FC**... Output flange
Flangia uscita

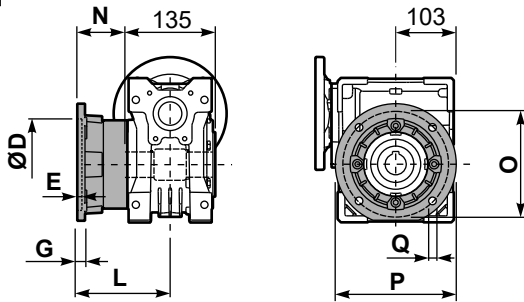

type B	øD	E	G	L	N	O	P	Q	kit code
FC	152 H8	5	16	111	43.5	176	205	13	K085.9.010
FL	180 H8	6	18	122	54.5	215	250	14	KM85.9.011

PM85**F1**... Output flange
Flangia uscita

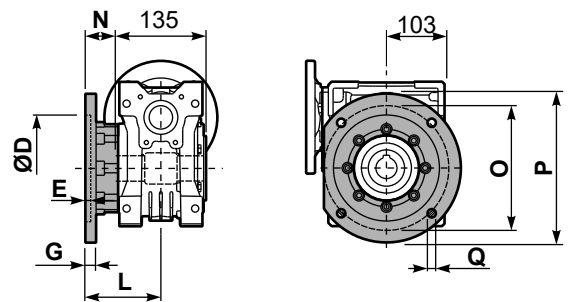

type S	øD	E	G	L	N	O	P	Q	kit code
F1	130 H8	5	13	109.5	42	165	200	13	KS085.9.015
F2	152 H8	5	16	151.5	84	176	205	13	K085.9.010 K085.0.201

PM85**FB**... Feet
Piedini

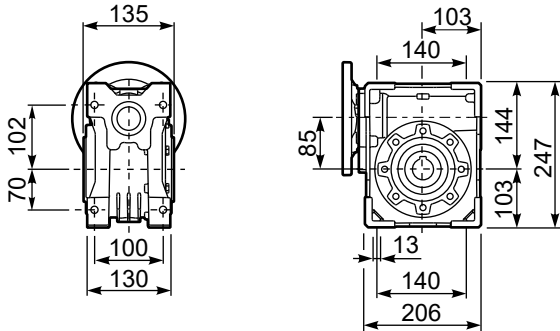

PM85**BR**... Reaction arm
Braccio di reazione

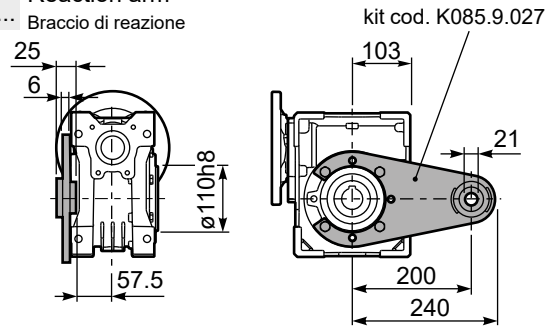

RM85**FB**... Input shaft
Albero in entrata

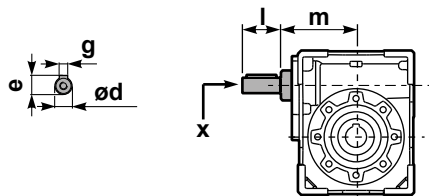

	ød	e	g	l	m	x	kit code
type B	25 h6	28	8	50	112	M8x20	① K085.5.007 PAM90 ② K085.5.008 PAM100
type S	24 h6	27	8	50	112	M8x20	① KS085.5.009 PAM90 ② KS085.5.011 PAM100

PM85...**S**... Single Shaft
Albero lento semplice

PM85...**D**... Double Shaft
Albero lento bisp.

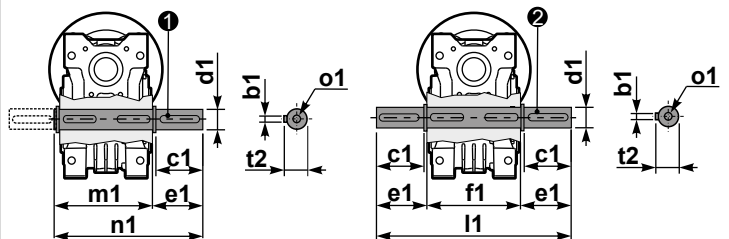

① kit cod. K085.5.028 type B ② kit cod. K085.5.029 type B

	b1	c1	d1	e1	f1	l1	m1	n1	t2	o1
type B	10	60	35 ^{-0.005} _{-0.020}	73.5	135	282	141	214.5	38	M10x23
type S	-	-	-	-	-	-	-	-	-	-



QUICK SELECTION / Selezione veloce

input speed (n_1) = 1400 min⁻¹

Output Speed n_2 [min ⁻¹]	Ratio i	Motor power P_{1M} [kW]	Output torque M_{2M} [Nm]	Service factor f.s.	Nominal power P_{1R} [kW]	Nominal torque M_{2R} [Nm]	Available B5 motor flanges					Available B14 motor flanges				Dynamic efficiency RD	Tooth Module [mm]	Ratios code	
							-C	-D	-E	-F	-G	-R	-T	-U	-V				
							71	80	90	100 112	132	80	90	100 112	132				
200	7	7.5	315	1.7	13.0	546		B	B				B	B			88	5.5	01
140	10	7.5	440	1.4	10.1	595		B	B				B	B			86	5.4	02
88	16	5.5	492	1.3	7.3	650		B	B				B	B			82	5.3	03
70	20	4.0	447	1.4	5.7	640		B	B				B	B			82	4.5	04
61	23	4.0	502	1.3	5.3	670		B	B				B	B			80	3.9	05
47	30	4.0	622	1.2	4.7	725		B	B				B	B			76	5.6	06
37	38	3.0	583	1.2	3.6	698		B	B				B	B			75	4.7	07
31	45	2.2	493	1.3	2.9	650		B	B				B	B			73	4.0	08
26	53	2.2	557	1.2	2.6	660		B	B				B	B			70	3.5	09
22	64	1.5	452	1.4	2.0	612	B	B					B				69	2.9	10
16.7	84	1.1	410	1.3	1.4	515	B	B					B				65	2.2	11
14.1	99	1.1	446	1.1	1.2	483	B	B					B				60	1.9	12

A) Motor Flanges Available
Flange Motore Disponibili

B) Supplied with Reduction Bushing
Fornito con Bussola di Riduzione

B) Available on Request without reduction bushing
Disponibile a Richiesta senza Bussola di Riduzione

C) Motor Flange Holes Position
Posizione Fori Flangia Motore

EN Unit M11 is supplied without lubricant and equipped with a breather, level and drain plugs. User can add mineral oil keeping existing plugs. Should the user wish to fill it with synthetic oil, it is recommended to replace the existing plugs with a closed plug.
See table 1 for lubrication and recommended quantity. In table 2 please see possible radial loads and axial loads on the gearbox.

I Il riduttore tipo M11 è fornito privo di lubrificazione con tappi di sfiato, livello e scarico olio. L'utente può immettere olio minerale mantenendo i tappi esistenti. Se immetterà olio sintetico, dovrà sostituire i tappi esistenti con altri tipo chiuso.
Tab.1 per oli e quantità consigliati.
Tab.2 carichi radiali e assiali applicabili al riduttore.

D Das Getriebe der Baugröße M11 wird ohne Schmiermittel geliefert. Es ist jedoch mit Einfüllschraube, Überdruckventil und Ablassschraube ausgerüstet. Das benötigte mineralische Öl kann über die Einfüllschraube eingefüllt werden. Sollte synthetisches Öl bevorzugt werden, so ist sind das eingebaute Überdruckventil durch eine geschlossenen Schraube zu ersetzen.
In Tabelle 1 ist die Schmiermenge und das empfohlene Schmiermittel angegeben
In Tabelle 2 sind die zulässigen Radial - und Axialbelastungen des Getriebes aufgeführt.

F Le réducteur de type M11 est fourni sans lubrification et avec un bouchon de remplissage, de niveau et d'évacuation de l'huile. L'utilisateur peut y verser de l'huile minérale en conservant les bouchons existants.
S'il y versera de l'huile synthétique, il devra substituer les bouchons existants avec d'autres bouchons de type fermé.
Voir tableau 1 concernant les huiles et les quantités conseillées.
Voir tableau 2 concernant les charges radiales et axiales applicables au réducteur.

E El reductor tamaño M11 se suministra sin lubricante, provisto de tapones de respiración, nivel y descarga de aceite. El usuario puede utilizar aceite mineral, manteniendo los tapones existentes. Si prefiere utilizar aceite sintético deberá sustituir los tapones existentes por tapones ciegos. La prerreducción se suministra con tapones ciegos, lubricado de por vida con aceite sintético.
Ver tabla 1, para cantidades y aceites recomendados.
En la tabla 2, se encuentran las cargas radiales y axiales admitidas por el reductor.

1.90 LT	1.35 LT	1.35 LT	2.00LT	2.00 LT	2.00LT
SHELL Omala S2 GX 460			ENI Blasias 460		

For all details on lubrication and plugs check our website [tab. 1](#)
Per maggiori dettagli su lubrificazione e tappi olio vedi il nostro sito web

*RADIAL AND AXIAL LOADS

Output shaft Albero di uscita		
n_2 [min ⁻¹]	FA [N]	FR [N]
200	600	2900
150	700	3300
100	750	3600
75	800	4000
50	920	4600
25	1200	6000
15	1400	7000

Input shaft albero in entrata		
n_1 [min ⁻¹]	FA [N]	FR [N]
1400	228	1140

*Strong axial loads in the DX direction are not allowed.
Non sono consentiti forti carichi assiali con direzione DX

tab. 2

PM11FB... Basic wormbox
Riduttore base

Gearbox weight
peso riduttore **35.0 kg**

M. flanges	Kit code	øF	A
71B5	K023.4.041	160	136
80/90B5	K023.4.042	200	138
100/112B5	K023.4.043	250	147
132B5	-	300	187
80B14	K085.4.046	120	138
90B14	K085.4.045	140	138
100/112B14	K023.4.041	160	136
132B14	-	200	187

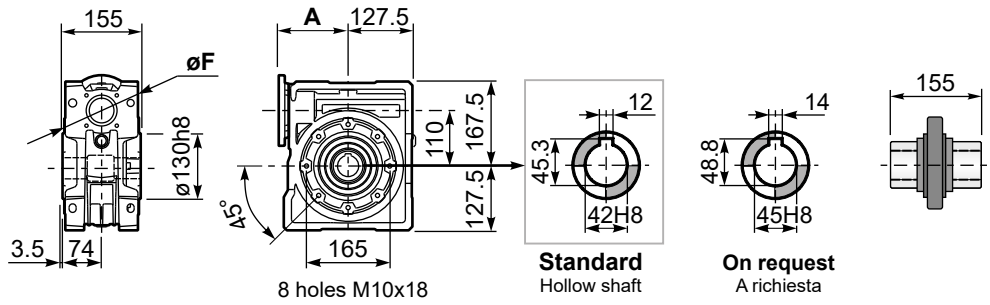

PM11FC... Output flange
Flangia uscita

PM11FL... Output flange
Flangia uscita

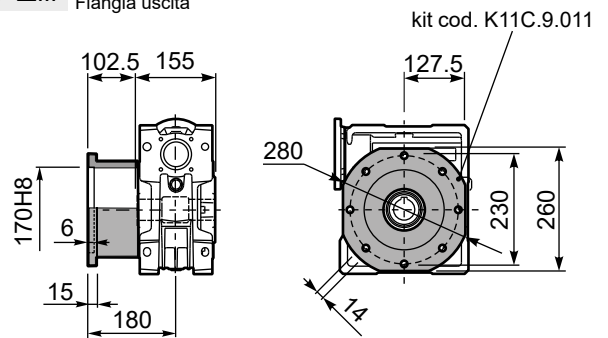
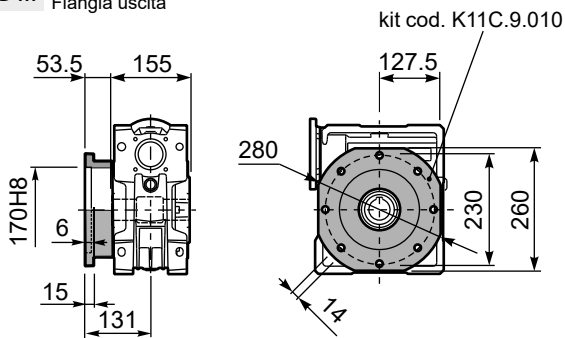

PM11FB... Feet
Piedini

PM11BR... Reaction arm
Braccio di reazione

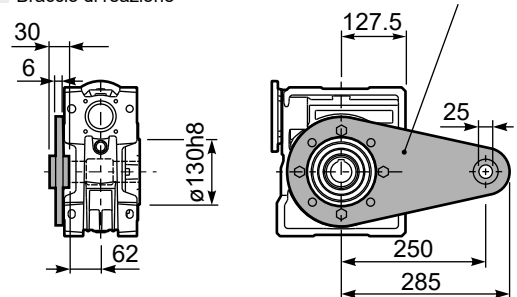
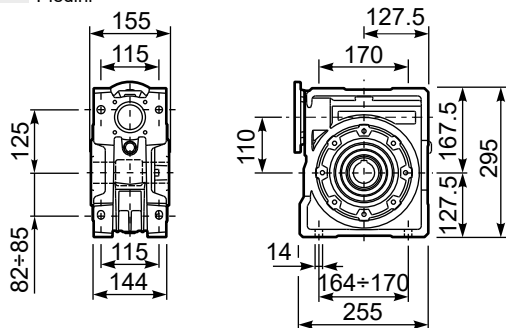

RM11FB... Input shaft
Albero in entrata

PM11.....S... Single Shaft
Albero lento semplice

PM11.....D... Double Shaft
Albero lento bisp.

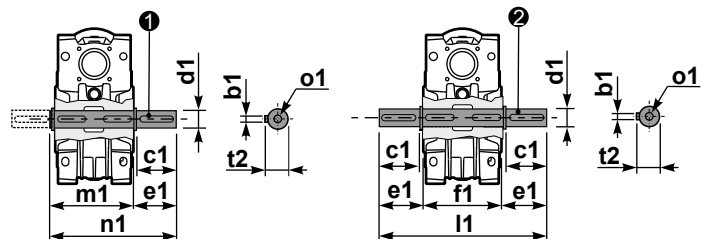
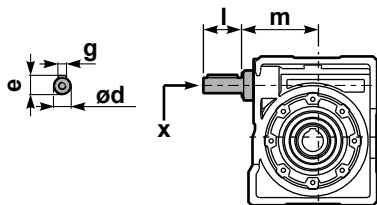

① kit cod. K11C.5.028 type B ② kit cod. K11C.5.029 type B

	ød	e	g	l	m	x	kit code
type B	25 h6	28	8	50	131.5	M8x20	① K085.5.007 PAM90 ② K085.5.008 PAM100
type S	24 h6	27	8	50	131.5	M8x20	① KS085.5.009 PAM90 ② KS085.5.011 PAM100

	b1	c1	d1	e1	f1	l1	m1	n1	t2	o1
type B	12	80	42h6	84.5	155	324	164.5	249	45	M16x28
type S	-	-	-	-	-	-	-	-	-	-



QUICK SELECTION / Selezione veloce

input speed (n_1) = 1400 min⁻¹

Output Speed n_2 [min ⁻¹]	Ratio i	Motor power P_{1M} [kW]	Output torque M_{2M} [Nm]	Service factor f.s.	Nominal power P_{1R} [kW]	Nominal torque M_{2R} [Nm]	Available B5 motor flanges			B14 motor flanges not available				Dynamic efficiency RD	Tooth Module [mm]	Ratios code
							-E	-F	-G	-	-	-	-			
							90	100 112	132	-	-	-	-			
187	7.5	7.5	345	2.1	16.1	741								90	6.11	01
140	10	7.5	455	1.8	13.5	820								89	6.45	02
93	15	7.5	668	1.4	10.3	917								87	6.72	03
70	20	7.5	870	1.0	7.8	905								85	5.24	04
56	25	5.5	788	1.2	6.5	931								84	4.28	05
46.7	30	5.5	900	1.2	6.4	1047								80	6.91	06
35	40	4.0	851	1.2	4.9	1043								78	5.36	07
28	50	4.0	1023	0.9	3.8	972								75	4.35	08
23.3	60	3.0	896	1.0	3.1	928								73	3.65	09
17.5	80	2.2	816	1.0	2.3	853								68	2.76	10
14	100	1.5	655	1.1	1.7	742								64	2.23	11

A Motor Flanges Available
Flange Motore Disponibili

B Supplied with Reduction Bushing
Fornito con Bussola di Riduzione

B Available on Request without reduction bushing
Disponibile a Richiesta senza Bussola di Riduzione

C Motor Flange Holes Position
Posizione Fori Flangia Motore

EN Unit **M13** is supplied without lubricant and equipped with a breather, level and drain plugs. User can add mineral oil keeping existing plugs. Should the user wish to fill it with synthetic oil, it is recommended to replace the existing plugs with a closed plug. See table 1 for lubrication and recommended quantity. In table 2 please see possible radial loads and axial loads on the gearbox.

I Il riduttore tipo **M13** è fornito privo di lubrificazione con tappi di sfiato, livello e scarico olio. L'utente può immettere olio minerale mantenendo i tappi esistenti. Se immetterà olio sintetico, dovrà sostituire i tappi esistenti con altri tipo chiuso. Tab.1 per oli e quantità consigliati. Tab.2 carichi radiali e assiali applicabili al riduttore.

D Das Getriebe der Baugröße **M13** wird ohne Schmiermittel geliefert. Es ist jedoch mit Einfüllschraube, Überdruckventil und Ablassschraube ausgerüstet. Das benötigte mineralische Öl kann über die Einfüllschraube eingefüllt werden. Sollte synthetisches Öl bevorzugt werden, so ist sind das eingebaute Überdruckventil durch eine geschlossenen Schraube zu ersetzen. In Tabelle 1 ist die Schmiermenge und das empfohlene Schmiermittel angegeben. In Tabelle 2 sind die zulässigen Radial - und Axialbelastungen des Getriebes aufgeführt.

F Le réducteur de type **M13** est fourni sans lubrification et avec un bouchon de remplissage, de niveau et d'évacuation de l'huile. L'utilisateur peut y verser de l'huile minérale en conservant les bouchons existants. S'il y versera de l'huile synthétique, il devra substituer les bouchons existants avec d'autres bouchons de type fermé. Voir tableau 1 concernant les huiles et les quantités conseillées. Voir tableau 2 concernant les charges radiales et axiales applicables au réducteur.

E El reductor tamaño **M13** se suministra sin lubricante, provisto de tapones de respiración, nivel y descarga de aceite. El usuario puede utilizar aceite mineral, manteniendo los tapones existentes. Si prefiere utilizar aceite sintético deberá sustituir los tapones existentes por tapones ciegos. La prerreducción se suministra con tapones ciegos, lubricado de por vida con aceite sintético. Ver tabla 1, para cantidades y aceites recomendados. En la tabla 2, se encuentran las cargas radiales y axiales admitidas por el reductor.

B3	B6	B7	B8	V5	V6
4.50 LT	3.50 LT	3.50 LT	3.30LT	4.50 LT	3.30LT
SHELL Omala S2 GX 460			ENI Blasias 460		

For all details on lubrication and plugs check our website **tab. 1**
Per maggiori dettagli su lubrificazione e tappi olio vedi il nostro sito web

RADIAL AND AXIAL LOADS

Output shaft
Albero di uscita

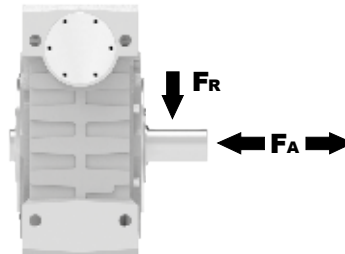

n_2 [min ⁻¹]	FA [N]	FR [N]
200	960	4800
150	1100	5500
100	1240	6200
75	1380	6900
50	1560	7800
25	2000	10000
15	2400	12000

Input shaft
albero in entrata

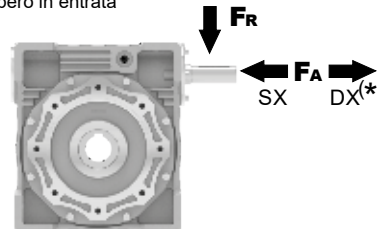

n_1 [min ⁻¹]	FA [N]	FR [N]
1400	300	1500

*Strong axial loads in the DX direction are not allowed.
Non sono consentiti forti carichi assiali con direzione DX

tab. 2

PM13**FB**... Basic wormbox
Riduttore base

Gearbox weight
peso riduttore **48.0 kg**

M. flanges	Kit code	øF	A
90B5	KM13.4.041	200	180
100/112B5	KM13.4.042	250	180
132B5	KM13.4.043	300	180

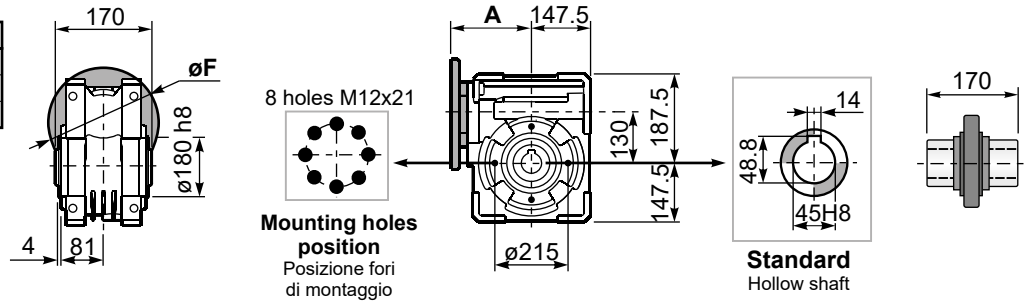

PM13**FC**... Square flange
Flangia quadrata

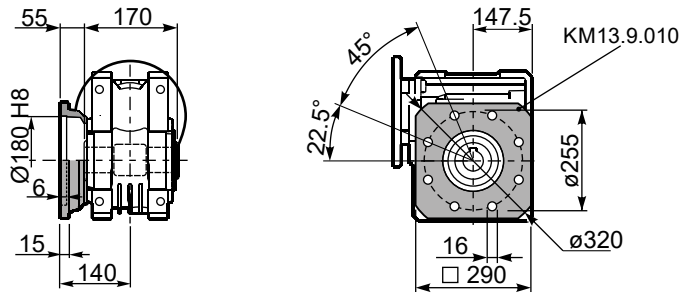

PM13**FB**... Feet
Piedini

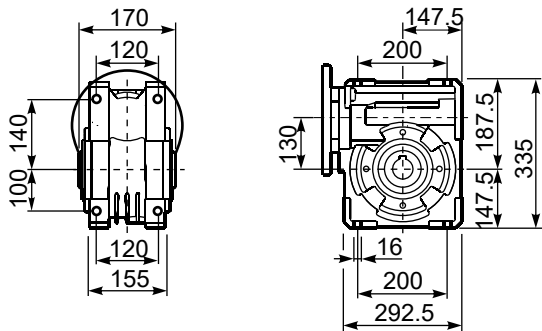

PM13**BR**... Reaction arm
Braccio di reazione

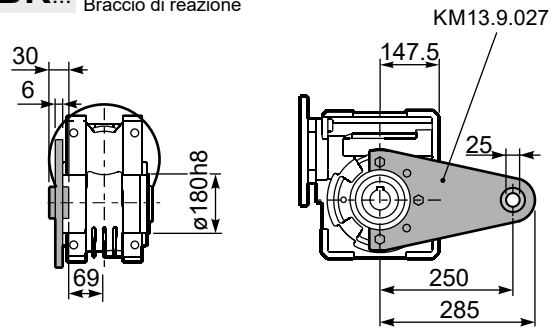

PM13....**S**... Single Shaft
Albero lento semplice

PM13....**D**... Double Shaft
Albero lento bisp.

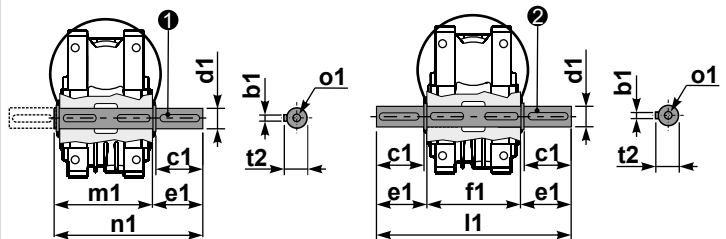

① kit cod. KM13.5.028 type B

② kit cod. KM13.5.029 type B

	b1	c1	d1	e1	f1	l1	m1	n1	t2	o1
type	14	80	45 ^{-0.005} _{-0.020}	85	170	340	180	265	48.5	M16
type	-	-	-	-	-	-	-	-	-	-



QUICK SELECTION / Selezione veloce

input speed (n_1) = 1400 min⁻¹

Output Speed n_2 [min ⁻¹]	Ratio i	Motor power P_{1M} [kW]	Output torque M_{2M} [Nm]	Service factor f.s.	Nominal power P_{1R} [kW]	Nominal torque M_{2R} [Nm]	Available B5 motor flanges			B14 motor flanges not available				Dynamic efficiency RD	Tooth Module [mm]	Ratios code
							-F	-G	-H	-	-	-	-			
							100	132	160	-	-	-	-			
187	7.5	15	698	1.7	25.8	1200								91	5.5	01
140	10	15	921	1.3	20.2	1240								90	6.155	02
93	15	11	990	1.3	13.9	1250								88	5.5	03
70	20	11	1291	1.0	11.1	1300								86	6.155	04
56	25	9	1289	0.9	8.4	1200								84	5	05
46.7	30	7.5	1274	0.9	7.1	1200								83	4.193	06
35	40	7.5	1596	1.0	7.3	1550								78	6.155	07
28	50	5.5	1426	1.0	5.4	1400								76	5	08
23.3	60	4	1195	1.1	4.2	1260								73	4.193	09
17.5	80	3	1113	1.0	3.1	1150								68	3.17	10
14	100	2.2	960	1.0	2.3	1000								64	2.55	11

A) Motor Flanges Available
Flange Motore Disponibili

B) Supplied with Reduction Bushing
Fornito con Bussola di Riduzione

B) Available on Request without reduction bushing
Disponibile a Richiesta senza Bussola di Riduzione

C) Motor Flange Holes Position
Posizione Fori Flangia Motore

EN Unit **M15** is supplied without lubricant and equipped with a breather, level and drain plugs. User can add mineral oil keeping existing plugs. Should the user wish to fill it with synthetic oil, it is recommended to replace the existing plugs with a closed plug. See table 1 for lubrication and recommended quantity. In table 2 please see possible radial loads and axial loads on the gearbox.

I Il riduttore tipo **M15** è fornito privo di lubrificazione con tappi di sfiato, livello e scarico olio. L'utente può immettere olio minerale mantenendo i tappi esistenti. Se immetterà olio sintetico, dovrà sostituire i tappi esistenti con altri tipo chiuso. Tab.1 per oli e quantità consigliati. Tab.2 carichi radiali e assiali applicabili al riduttore.

D Das Getriebe der Baugröße **M15** wird ohne Schmiermittel geliefert. Es ist jedoch mit Einfüllschraube, Überdruckventil und Ablassschraube ausgerüstet. Das benötigte mineralische Öl kann über die Einfüllschraube eingefüllt werden. Sollte synthetisches Öl bevorzugt werden, so ist sind das eingebaute Überdruckventil durch eine geschlossenen Schraube zu ersetzen. In Tabelle 1 ist die Schmiermenge und das empfohlene Schmiermittel angegeben. In Tabelle 2 sind die zulässigen Radial - und Axialbelastungen des Getriebes aufgeführt.

F Le réducteur de type **M15** est fourni sans lubrification et avec un bouchon de remplissage, de niveau et d'évacuation de l'huile. L'utilisateur peut y verser de l'huile minérale en conservant les bouchons existants. S'il y versera de l'huile synthétique, il devra substituer les bouchons existants avec d'autres bouchons de type fermé. Voir tableau 1 concernant les huiles et les quantités conseillées. Voir tableau 2 concernant les charges radiales et axiales applicables au réducteur.

E El reductor tamaño **M15** se suministra sin lubricante, provisto de tapones de respiración, nivel y descarga de aceite. El usuario puede utilizar aceite mineral, manteniendo los tapones existentes. Si prefiere utilizar aceite sintético deberá sustituir los tapones existentes por tapones ciegos. La prerreducción se suministra con tapones ciegos, lubricado de por vida con aceite sintético. Ver tabla 1, para cantidades y aceites recomendados. En la tabla 2, se encuentran las cargas radiales y axiales admitidas por el reductor.

B3	B6	B7	B8	V5	V6
7.00 LT	5.40 LT	5.40 LT	5.10 LT	7.00 LT	5.10 LT
SHELL Omala S2 GX 460			ENI Blasias 460		

For all details on lubrication and plugs check our website **tab. 1**
Per maggiori dettagli su lubrificazione e tappi olio vedi il nostro sito web

RADIAL AND AXIAL LOADS

Output shaft
Albero di uscita

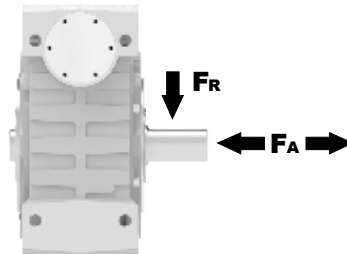

n_2 [min ⁻¹]	FA [N]	FR [N]
200	1300	6500
150	1440	7200
100	1640	8200
75	1800	9000
50	2120	10600
25	2700	13500
15	3300	16500

Input shaft
albero in entrata

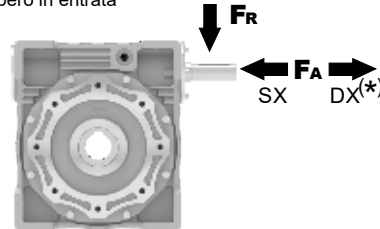

n_1 [min ⁻¹]	FA [N]	FR [N]
1400	400	2000

***Strong axial loads in the DX direction are not allowed.**
Non sono consentiti forti carichi assiali con direzione DX

tab. 2

PM15**FB**... Basic wormbox
Riduttore base

Gearbox weight
peso riduttore **84.0 kg**

M. flanges	Kit code	øF	A
100/112B5	KM15.4.042	250	210
132B5	KM15.4.043	300	210
160B5	KM15.4.044	350	210

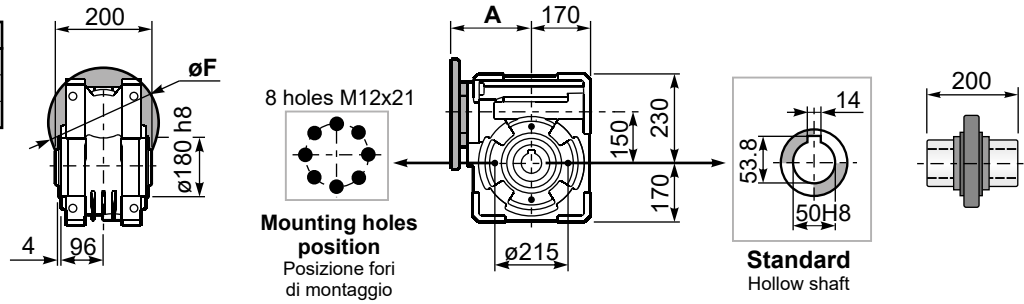

PM15**FC**... Square flange
Flangia quadrata

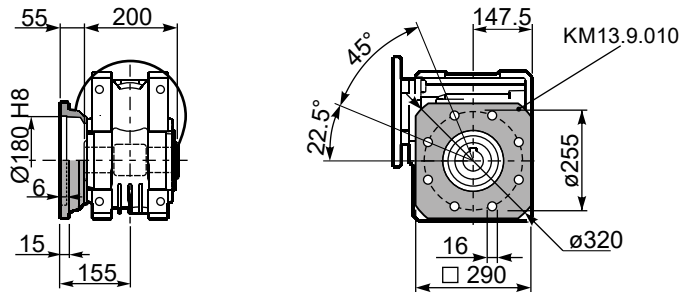

PM15**FB**... Feet
Piedini

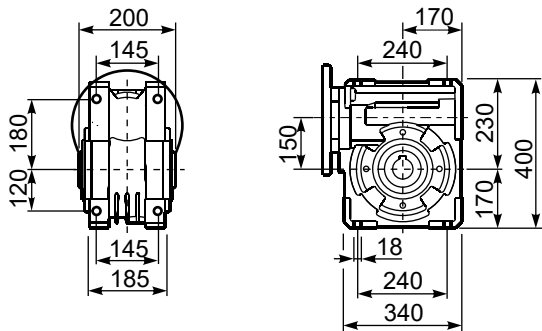

PM15**BR**... Reaction arm
Braccio di reazione

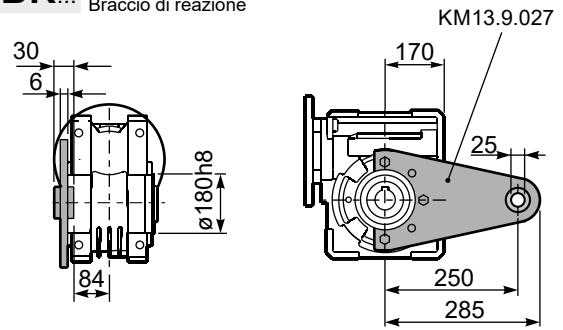

PM15....**S**... Single Shaft
Albero lento semplice

PM15....**D**... Double Shaft
Albero lento bisp.

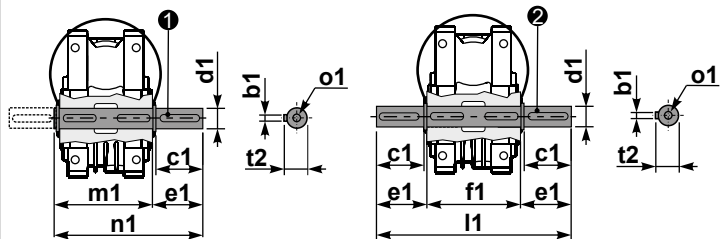

① kit cod. KM15.5.028 type B

② kit cod. KM15.5.029 type B

	b1	c1	d1	e1	f1	l1	m1	n1	t2	o1
type	14	82	50 ^{-0.005} _{-0.020}	87	200	374	210	297	53.5	M16
type	-	-	-	-	-	-	-	-	-	-

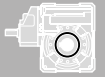

QUICK SELECTION / Selezione veloce

input speed (n_1) = 1400 min⁻¹

Output Speed n_2 [min ⁻¹]	Ratio i	Motor power P_{1M} [kW]	Output torque M_{2M} [Nm]	Service factor f.s.	Nominal power P_{1R} [kW]	Nominal torque M_{2R} [Nm]	Available B5 motor flanges			Available B14 motor flanges		Dynamic efficiency RD	Tooth Module [mm]	Ratios code
							-A	-B	-C	-P	-Q			
							56	63	71	63	71			
47	30.1	0.25	38	1.4	0.36	55				C		74	2.2	01
33	43.0	0.25	53	1.0	0.26	55				C		72	2.2	02
23	60.2	0.25	62	0.9	0.22	55				C		60	2.4	03
15.5	90.3	0.12	42	1.3	0.16	55				C		57	1.6	04
11.6	120	0.12	52	1.1	0.13	55				C		53	2.5	05
8.8	159	0.12	64	0.9	0.10	55				C		49	1.8	06
7.1	198	0.12*	55	<0.8	0.09	55				C		47	1.5	07
5.4	258	0.12*	55	<0.8	0.07	55				C		45	1.2	08
4.7	301	0.12*	39	<0.8	0.05	39				C		40	1.0	09
3.2	439	0.12*	39	<0.8	0.04	39				C		36	0.72	10

A Motor Flanges Available
Flange Motore Disponibili

B Supplied with Reduction Bushing
Fornito con Bussola di Riduzione

B Available on Request without reduction bushing
Disponibile a Richiesta senza Bussola di Riduzione

C Motor Flange Holes Position
Posizione Fori Flangia Motore

* Power higher than the maximum one which can be supported by the gearbox. Select according to the torque M_{2R}
Potenza superiore a quella massima sopportabile dal riduttore. Selezionare in base al momento torcente M_{2R}

EN Unit **P4M** is supplied with synthetic oil, providing "long life" lubrication. For mounting position V5-V6 please contact us. See table 1 for lubrication and recommended quantity. In table 2 please see possible radial loads and axial loads on the gearbox.

I Il riduttore tipo **P4M** viene fornito lubrificato a vita con olio sintetico. Per posizioni V5-V6 contattare il ns. servizio tecnico. Vedi tab.1 per oli e quantità consigliati. In tab.2 sono presenti i carichi radiali e assiali applicabili al riduttore.

D Für die Lebensdauerschmierung ist das Getriebe der Größe **P4M** mit synthetischem Öl befüllt. Bei Einbaulage V5 oder V6 bitten wir um Rücksprache. In Tabelle 1 ist die Schmiermenge und das empfohlene Schmiermittel angegeben. In Tabelle 2 sind die zulässigen Radial- und Axialbelastungen des Getriebes aufgeführt.

F Le réducteur de type **P4M** est fourni lubrifié à vie avec de l'huile synthétique. Concernant les positions V5.V6, contactez notre service d'assistance technique. Voir tableau 1 concernant les huiles et les quantités conseillées. Les charges radiales et axiales applicables au réducteur sont précisées dans le tableau 2.

E El reductor tamaño **P4M** se suministra, lubricado de por vida con aceite sintético. Para las posiciones V5 y V6 contactar con nuestro servicio técnico. Ver tabla 1, para cantidades y aceites recomendados. En la tabla 2, se encuentran las cargas radiales y axiales admitidas por el reductor.

LUBRICATION P4M Oil
Common lubrication 0.17 l (A + B).

SHELL Omala S4 WE 320	ENI Telium VSF 320
------------------------------	---------------------------

For all details on lubrication and plugs check our website **tab. 1**
Per maggiori dettagli su lubrificazione e tappi olio vedi il nostro sito web

RADIAL AND AXIAL LOADS

Output shaft
Albero di uscita

n_2 [min ⁻¹]	FA [N]	FR [N]
75	240	1200
50	260	1400
25	300	1800
15-6	400	2000

Input shaft
albero in entrata

n_1 [min ⁻¹]	FA [N]	FR [N]
1400	44	220

*Strong axial loads in the DX direction are not allowed.
Non sono consentiti forti carichi assiali con direzione DX

tab. 2

PP4MFB... Basic wormbox
Riduttore base

M. flanges	Kit code	øF	A
56B5	K050.4.046	120	143.5
63B5	K050.4.041	138	145.5
71B5	K050.4.042	160	143
63B14	K050.4.047	90	145.5
71B14	K050.4.045	105	143

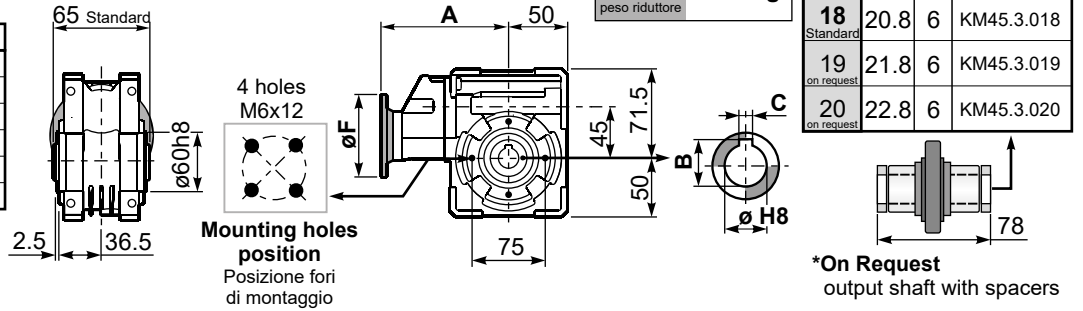

PP4MFC... Square flange
Flangia quadrata

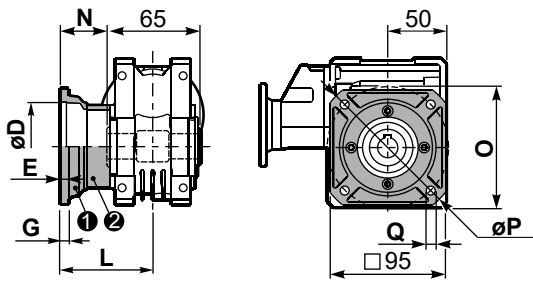

type B	øD	E	G	L	N	O	P	Q	kit code
FC	60 H8	4	7	67	34.5	75	110	9	KM45.9.010
FL	60 H8	4	7	97	64.5	75	110	9	KM45.9.011

PP4MF1... Round flange
Flangia rotonda

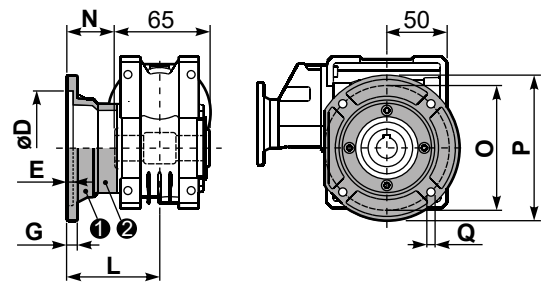

type S	øD	E	G	L	N	O	P	Q	kit code
F1	95H8	5	9	80	47.5	115	140	9.5	KM45.9.012
F2	-	-	-	-	-	-	-	-	-

PP4MFB... Feet
Piedini

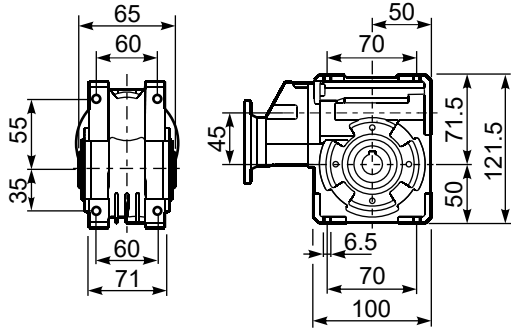

PP4MBR... Reaction arm
Braccio di reazione

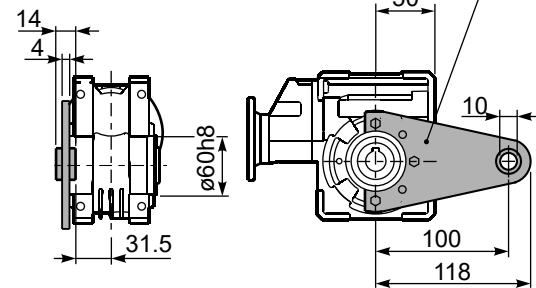

RP4MFB... Input shaft
Albero in entrata

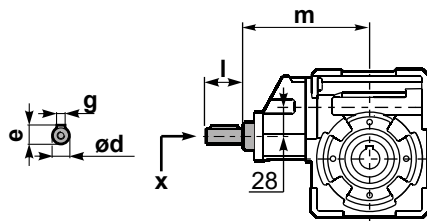

	ød	e	g	l	m	x	
type B	14 h6	16	5	25	141	M5x13	C35.5.061
type S	-	-	-	-	-	-	-

PP4M....S... Single Shaft
Albero lento semplice

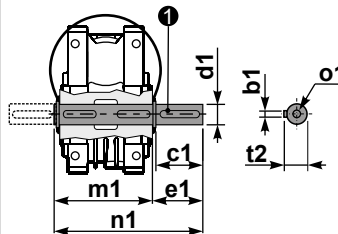

PP4M....D... Double Shaft
Albero lento bisp.

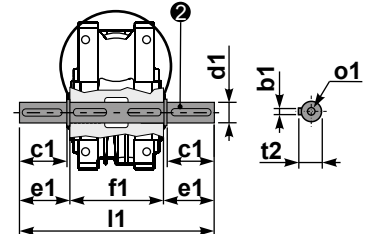

① kit cod. K045.5.028 type B
kit cod. KS045.5.030 type S

② kit cod. K045.5.029 type B

	b1	c1	d1	e1	f1	l1	m1	n1	t2	o1
type B	6	32	18 ^{-0.005} -0.020	43	65	151	70	113	20.5	M6x18
type S	6	40	19 ^{-0.005} -0.020	58.5	-	-	70	128.5	21.5	M8x20

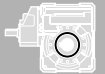

QUICK SELECTION / Selezione veloce

input speed (n_1) = 1400 min⁻¹

Output Speed n_2 [min ⁻¹]	Ratio i	Motor power P_{1M} [kW]	Output torque M_{2M} [Nm]	Service factor f.s.	Nominal power P_{1R} [kW]	Nominal torque M_{2R} [Nm]	Available B5 motor flanges			Available B14 motor flanges		Dynamic efficiency RD	Tooth Module [mm]	Ratios code
							-A	-B	-C	-P	-Q			
							56	63	71	63	71			
47	30.1	0.37	58	1.3	0.49	77				C		76	2.5	01
33	43.0	0.25	55	1.4	0.35	77				C		75	2.4	02
23	60.2	0.25	71	1.1	0.27	77				C		69	2.6	03
18.1	77.4	0.25	81	1.1	0.27	88				C		61	2.0	04
12.5	112	0.18	84	1.1	0.19	88				C		61	2.7	05
9.0	155	0.12	71	1.2	0.15	88				C		56	2.1	06
7.6	185	0.12	74	1.0	0.12	77				C		49	1.8	07
5.4	258	0.12*	77	<0.8	0.09	77				C		47	1.3	08
4.8	292	0.12*	66	<0.8	0.08	66				C		44	1.2	09
4.1	344	0.12*	44	<0.8	0.05	44				C		40	1.0	10
3.3	430	0.12*	44	<0.8	0.04	44				C		36	0.8	11

A Motor Flanges Available
Flange Motore Disponibili

B Supplied with Reduction Bushing
Fornito con Bussola di Riduzione

B Available on Request without reduction bushing
Disponibile a Richiesta senza Bussola di Riduzione

C Motor Flange Holes Position
Posizione Fori Flangia Motore

* Power higher than the maximum one which can be supported by the gearbox. Select according to the torque M_{2R}
Potenza superiore a quella massima sopportabile dal riduttore. Selezionare in base al momento torcente M_{2R}

EN Unit **P5M** is supplied with synthetic oil, providing "long life" lubrication. For mounting position V5-V6 please contact us.
See table 1 for lubrication and recommended quantity. In table 2 please see possible radial loads and axial loads on the gearbox.

I Il riduttore tipo **P5M** viene fornito lubrificato a vita con olio sintetico. Per posizioni V5-V6 contattare il ns. servizio tecnico.
Vedi tab.1 per oli e quantità consigliati. In tab.2 sono presenti i carichi radiali e assiali applicabili al riduttore.

D Für die Lebensdauerschmierung ist das Getriebe der Größe **P5M** mit synthetischem Öl befüllt. Bei Einbaulage V5 oder V6 bitten wir um Rücksprache. In Tabelle 1 ist die Schmiermenge und das empfohlene Schmiermittel angegeben. In Tabelle 2 sind die zulässigen Radial- und Axialbelastungen des Getriebes aufgeführt.

F Le réducteur de type **P5M** est fourni lubrifié à vie avec de l'huile synthétique. Concernant les positions V5.V6, contactez notre service d'assistance technique. Voir tableau 1 concernant les huiles et les quantités conseillées. Les charges radiales et axiales applicables au réducteur sont précisées dans le tableau 2.

E El reductor tamaño **P5M** se suministra, lubricado de por vida con aceite sintético. Para las posiciones V5 y V6 contactar con nuestro servicio técnico. Ver tabla 1, para cantidades y aceites recomendados. En la tabla 2, se encuentran las cargas radiales y axiales admitidas por el reductor.

LUBRICATION P5M Oil **A** **B**
Common lubrication 0.26 l (A + B).

SHELL Omala S4 WE 320	ENI Telium VSF 320
------------------------------	---------------------------

For all details on lubrication and plugs check our website **tab. 1**
Per maggiori dettagli su lubrificazione e tappi olio vedi il nostro sito web

RADIAL AND AXIAL LOADS

Output shaft
Albero di uscita

n_2 [min ⁻¹]	F_A [N]	F_R [N]
75	340	1700
50	380	1900
25	480	2500
15-6	560	2800

Input shaft
albero in entrata

n_1 [min ⁻¹]	F_A [N]	F_R [N]
1400	44	220

***Strong axial loads in the DX direction are not allowed.**
Non sono consentiti forti carichi assiali con direzione DX

tab. 2

PP5MFB... Basic wormbox
Riduttore base

M. flanges	Kit code	øF	A
56B5	K050.4.046	120	147
63B5	K050.4.041	138	149
71B5	K050.4.042	160	146.5
63B14	K050.4.047	90	149
71B14	K050.4.045	105	146.5

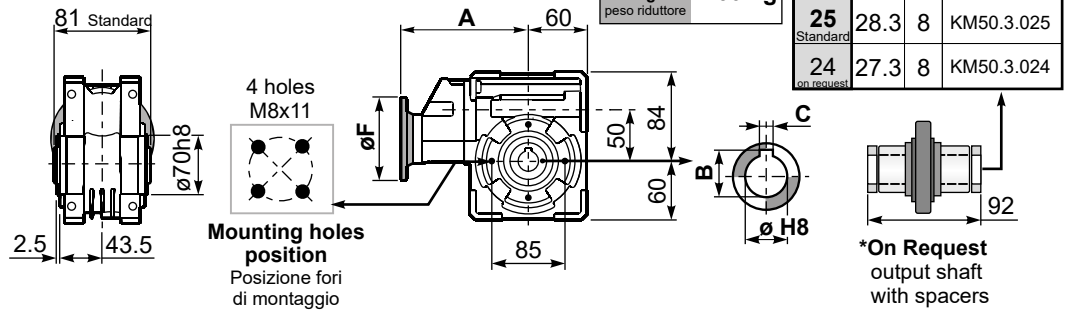

PP5MFC... Square flange
Flangia quadrata

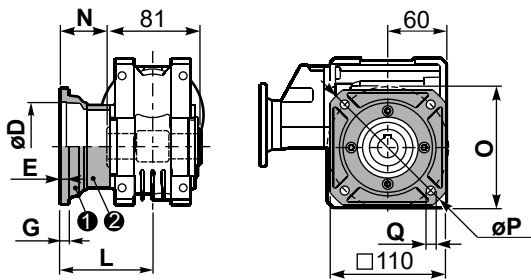

type B	øD	E	G	L	N	O	P	Q	kit code
FC	70 H8	5	9	90	49.5	85	125	11	KM50.9.010
FL	70 H8	5	9	120	79.5	85	125	11	KM50.9.011

PP5MF1... Round flange
Flangia rotonda

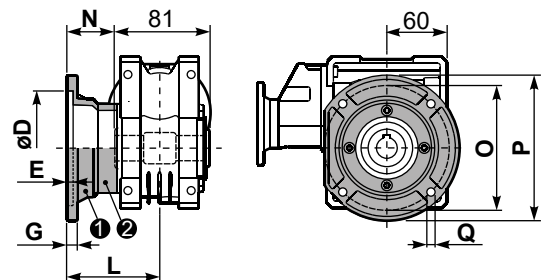

type S	øD	E	G	L	N	O	P	Q	kit code
F1	110 H8	5	10	89	69.5	130	160	9.5	KM50.9.012
F2	95 H8	5	14.5	72	31.5	115	140	11	KM50.9.013

PP5MFB... Feet
Piedini

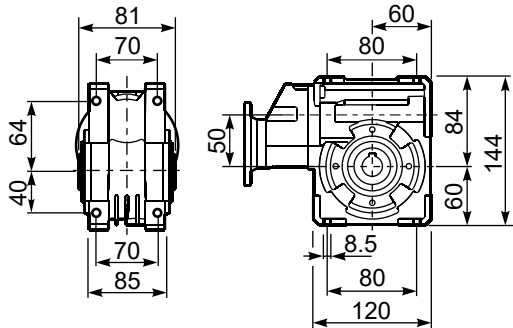

PP5MBR... Reaction arm
Braccio di reazione

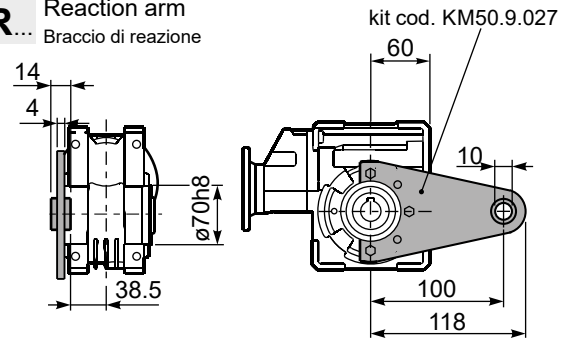

RP5MFB... Input shaft
Albero in entrata

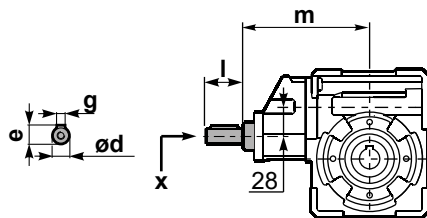

type	ød	e	g	l	m	x	
type B	14 h6	16	5	25	140.5	M5x13	C35.5.061
type S	-	-	-	-	-	-	-

PP5M...S... Single Shaft
Albero lento semplice

PP5M...D... Double Shaft
Albero lento bisp.

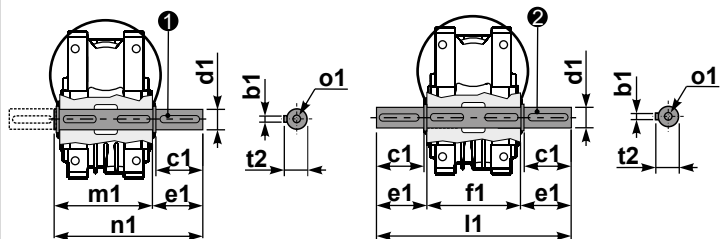

① kit cod. K050.5.028 type B
kit cod. KS050.5.030 type S

② kit cod. K050.5.029 type B

type	b1	c1	d1	e1	f1	l1	m1	n1	t2	o1
type B	8	52	25 ^{-0.005} _{-0.020}	59.5	81	200	86.5	146	28	M8x20
type S	8	50	24 ^{-0.005} _{-0.020}	68.8	-	-	86.5	155	27	M8x20

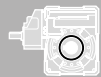

QUICK SELECTION / Selezione veloce

input speed (n_1) = 1400 min⁻¹

	Output Speed n_2 [min ⁻¹]	Ratio i	Motor power P_{1M} [kW]	Output torque M_{2M} [Nm]	Service factor f.s.	Nominal power P_{1R} [kW]	Nominal torque M_{2R} [Nm]	Available B5 motor flanges				Available B14 motor flanges				Dynamic efficiency RD	Tooth Module [mm]	Ratios code
								-B	-C	-D	-E	-P	-Q	-R	-T			
								63	71	80	90	63	71	80	90			
IEC 90 - 80 - 71	47	29.9	0.75	113	1.5	1.1	165					C	C		74	2.6	01	
	37	37.7	0.75	141	1.2	0.88	165					C	C		73	2.0	02	
	30	47.1	0.75	169	1.1	0.83	187					C	C		70	3.2	03	
	25	56.6	0.55	136	1.4	0.76	187					C	C		64	2.7	04	
	19.8	70.7	0.55	164	1.1	0.63	187					C	C		62	2.1	05	
	15.9	87.8	0.37	162	1.2	0.43	187					C	C		73	2.6	06	
	12.6	111.0	0.37	199	0.9	0.35	187					C	C		71	2.0	07	
IEC 71 - 63	10.1	139	0.37	234	0.8	0.30	187					C			67	3.2	08	
	8.4	166	0.25	173	1.1	0.27	187					C			61	2.7	09	
	6.7	208	0.18	151	1.1	0.20	165					C			59	2.1	10	
	4.5	310	0.12	129	1.3	0.15	165					C			51	1.5	11	
	3.8	370	0.12	145	1.1	0.14	165					C			48	1.3	12	
	3.2	434	0.12	149	0.9	0.11	138					C			42	1.1	13	

Motor Flanges Available Flange Motore Disponibili
 B) Supplied with Reduction Bushing Fornito con Bussola di Riduzione
 B) Available on Request without reduction bushing Disponibile a Richiesta senza Bussola di Riduzione
 C) Motor Flange Holes Position Posizione Fori Flangia Motore

EN Unit **P6M** is supplied with synthetic oil, providing "long life" lubrication. For mounting position V5-V6 please contact us. See table 1 for lubrication and recommended quantity. In table 2 please see possible radial loads and axial loads on the gearbox.

I Il riduttore tipo **P6M** viene fornito lubrificato a vita con olio sintetico. Per posizioni V5-V6 contattare il ns. servizio tecnico. Vedi tab.1 per oli e quantità consigliati. In tab.2 sono presenti i carichi radiali e assiali applicabili al riduttore.

D Für die Lebensdauerschmierung ist das Getriebe der Größe **P6M** mit synthetischem Öl befüllt. Bei Einbaulage V5 oder V6 bitten wir um Rücksprache. In Tabelle 1 ist die Schmiermenge und das empfohlene Schmiermittel angegeben. In Tabelle 2 sind die zulässigen Radial- und Axialbelastungen des Getriebes aufgeführt.

F Le réducteur de type **P6M** est fourni lubrifié à vie avec de l'huile synthétique. Concernant les positions V5.V6, contactez notre service d'assistance technique. Voir tableau 1 concernant les huiles et les quantités conseillées. Les charges radiales et axiales applicables au réducteur sont précisées dans le tableau 2.

E El reductor tamaño **P6M** se suministra, lubricado de por vida con aceite sintético. Para las posiciones V5 y V6 contactar con nuestro servicio técnico. Ver tabla 1, para cantidades y aceites recomendados. En la tabla 2, se encuentran las cargas radiales y axiales admitidas por el reductor.

LUBRICATION P6M Oil

For B3-V5-V6 separate lubrication for A (0.30 l) B (0.08 l), for B6-B7-B8 common lubrication 0.35 l (A + B).

SHELL Omala S4 WE 320 **ENI** Telium VSF 320

For all details on lubrication and plugs check our website **tab. 1**
Per maggiori dettagli su lubrificazione e tappi olio vedi il nostro sito web

RADIAL AND AXIAL LOADS

Output shaft
Albero di uscita

n_2 [min ⁻¹]	FA [N]	FR [N]
75	500	2500
50	600	3000
25	700	3800
15-6	800	4000

Input shaft
albero in entrata

n_1 [min ⁻¹]	FA [N]	FR [N]
1400	61	305

***Strong axial loads in the DX direction are not allowed.**
Non sono consentiti forti carichi assiali con direzione DX

tab. 2

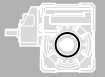

QUICK SELECTION / Selezione veloce

input speed (n₁) = 1400 min⁻¹

Output Speed n ₂ [min ⁻¹]	Ratio i	Motor power P _{1M} [kW]	Output torque M _{2M} [Nm]	Service factor f.s.	Nominal power P _{1R} [kW]	Nominal torque M _{2R} [Nm]	Available B5 motor flanges				Available B14 motor flanges			Dynamic efficiency RD	Tooth Module [mm]	Ratios code
							-B	-C	-D	-E	-Q	-R	-T			
							63	71	80	90	71	80	90			
22	62.9	0.75	248	1.2	0.87	286					C	C		77	3.10	01
18	78.5	0.75	293	1.0	0.73	286					C	C		73	2.41	02
15	94.2	0.75	333	0.9	0.70	310					C	C		69	2.10	03
11	126	0.55	297	1.0	0.55	296	B				C	C		63	1.53	04
9	157	0.37	230	1.1	0.41	252	B				C	C		58	1.23	05
8	185	0.37	257	1.2	0.43	296	B				C	C		55	3.10	06
6	231	0.25	193	1.5	0.38	296	B				C	C		49	2.41	07
5	277	0.25	222	1.3	0.33	296	B				C	C		47	2.10	08
4	378	0.18	200	1.5	0.27	296	B				C	C		43	2.10	09

Motor Flanges Available
Flange Motore Disponibili

B) Supplied with Reduction Bushing
Fornito con Bussola di Riduzione

B) Available on Request without reduction bushing
Disponibile a Richiesta senza Bussola di Riduzione

C) Motor Flange Holes Position
Posizione Fori Flangia Motore

* Power higher than the maximum one which can be supported by the gearbox. Select according to the torque M_{2R}
Potenza superiore a quella massima sopportabile dal riduttore. Selezionare in base al momento torcente M_{2R}

EN Unit P7M is supplied with synthetic oil, providing "long life" lubrication. For mounting position V5-V6 please contact us. See table 1 for lubrication and recommended quantity. In table 2 please see possible radial loads and axial loads on the gearbox.

I Il riduttore tipo P7M viene fornito lubrificato a vita con olio sintetico. Per posizioni V5-V6 contattare il ns. servizio tecnico. Vedi tab.1 per oli e quantità consigliati. In tab.2 sono presenti i carichi radiali e assiali applicabili al riduttore.

D Für die Lebensdauerschmierung ist das Getriebe der Größe P7M mit synthetischem Öl befüllt. Bei Einbaulage V5 oder V6 bitten wir um Rücksprache. In Tabelle 1 ist die Schmiermenge und das empfohlene Schmiermittel angegeben. In Tabelle 2 sind die zulässigen Radial- und Axialbelastungen des Getriebes aufgeführt.

F Le réducteur de type P7M est fourni lubrifié à vie avec de l'huile synthétique. Concernant les positions V5.V6, contactez notre service d'assistance technique. Voir tableau 1 concernant les huiles et les quantités conseillées. Les charges radiales et axiales applicables au réducteur sont précisées dans le tableau 2.

E El reductor tamaño P7M se suministra, lubricado de por vida con aceite sintético. Para las posiciones V5 y V6 contactar con nuestro servicio técnico. Ver tabla 1, para cantidades y aceites recomendados. En la tabla 2, se encuentran las cargas radiales y axiales admitidas por el reductor.

LUBRICATION P7M Oil

For B3-V5-V6 separate lubrication for A (0.40 l) B (0.14 l), for B6-B7-B8 common lubrication 0.65 l (A + B).

SHELL Omala S4 WE 320 **ENI** Telium VSF 320

For all details on lubrication and plugs check our website **tab. 1**
Per maggiori dettagli su lubrificazione e tappi olio vedi il nostro sito web

RADIAL AND AXIAL LOADS

Output shaft
Albero di uscita

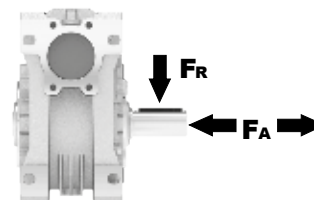

n ₂ [min ⁻¹]	FA [N]	FR [N]
75	620	3100
50	720	3600
25	880	4400
15-6	1000	5000

Input shaft
albero in entrata

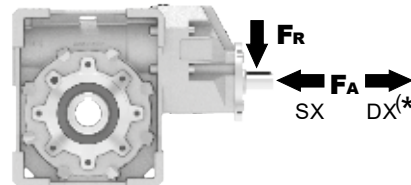

n [min ⁻¹]	FA [N]	FR [N]
1400	108	540

*Strong axial loads in the DX direction are not allowed.
Non sono consentiti forti carichi assiali con direzione DX

tab. 2

PP7M**FB**... Basic wormbox
Riduttore base

Gearbox weight
peso riduttore **9.90 kg**

M. flanges	Kit code	øF	A
63B5	K063.4.041	140	192.7
71B5	K063.4.042	160	190.7
80/90B5	K063.4.043	200	192.7
71B14	K063.4.047	105	190.7
80B14	K063.4.046	120	192.7
90B14	K063.4.041	140	192.7

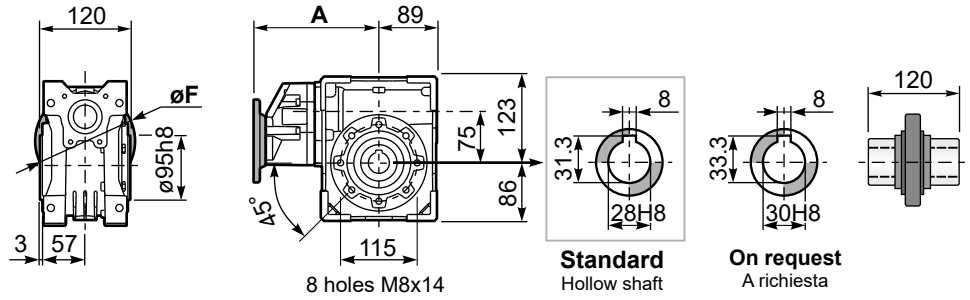

PP7M**FC**... Square flange
Flangia quadrata

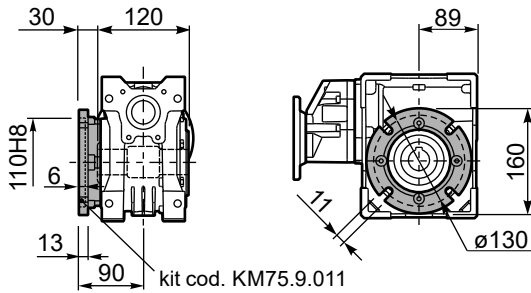

PP7M**FL**... Square flange
Flangia quadrata

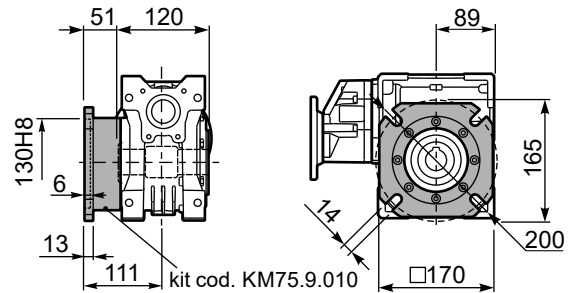

PP7M**FB**... Feet
Piedini

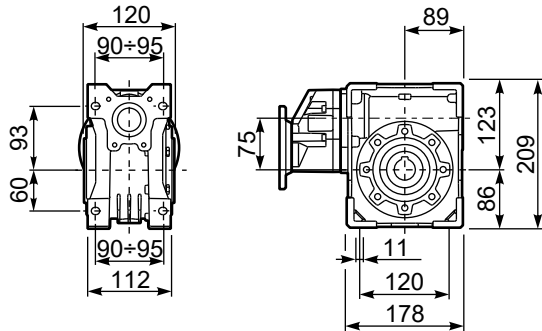

PP7M**BR**... Reaction arm
Braccio di reazione

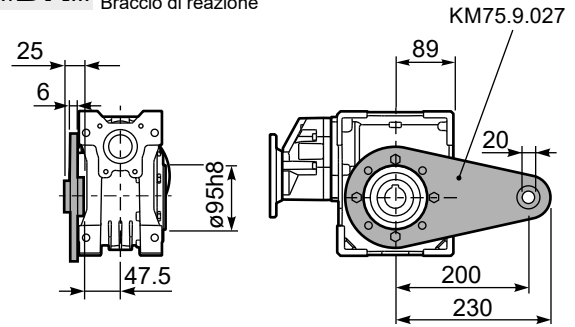

RP7M**F**B... Input shaft
Albero in entrata

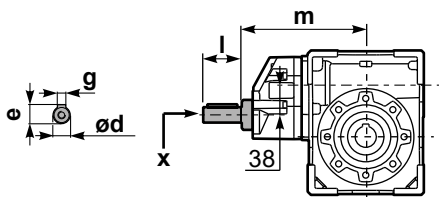

PP7M.....**S**... Single Shaft
Albero lento semplice

PP7M.....**D**... Double Shaft
Albero lento bisp.

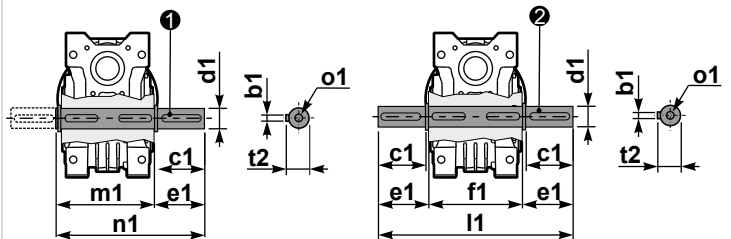

① kit cod. KM75.5.028 Standard

② kit cod. KM75.5.029 Standard

	ød	e	g	l	m	x	kit code
type B	19 h6	21.5	6	35	185.5	M6x16	C40.5.062

	b1	c1	d1	e1	f1	l1	m1	n1	t2	o1
Standard	8	60	28 h6	63.5	120	247	128.5	192	31	M10
On request	-	-	-	-	-	-	-	-	-	-

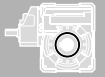

QUICK SELECTION / Selezione veloce

input speed (n_1) = 1400 min⁻¹

Output Speed n_2 [min ⁻¹]	Ratio i	Motor power P_{1M} [kW]	Output torque M_{2M} [Nm]	Service factor f.s.	Nominal power P_{1R} [kW]	Nominal torque M_{2R} [Nm]	Available B5 motor flanges				Available B14 motor flanges			Dynamic efficiency RD	Tooth Module [mm]	Ratios code
							-B	-C	-D	-E	-Q	-R	-T			
							63	71	80	90	71	80	90			
23.5	59.7	1.1	300	1.4	1.5	418					C	C		67	3.5	01
19.4	72.3	1.1	347	1.2	1.3	407					C	C		64	3.1	02
17.1	81.7	1.1	374	1.1	1.2	418					C	C		61	2.7	03
13.3	105	0.75	323	1.2	0.89	385					C	C		60	2.1	04
8.0	176	0.55	415	1.1	0.58	440	B				C	C		63	3.5	05
6.6	213	0.37	322	1.3	0.47	407	B				C	C		60	3.1	06
5.8	240	0.37	321	1.3	0.48	418	B				C	C		53	2.7	07
4.3	328	0.37	438	1.0	0.35	418	B				C	C		53	2.7	08
3.3	422	0.25	374	1.0	0.26	385	B				C	C		52	2.1	09
3.0	466	0.25	358	0.9	0.23	330	B				C	C		45	1.9	10
2.3	605	0.18	297	1.1	0.20	330	B				C	C		40	1.5	11

Motor Flanges Available
Flange Motore Disponibili

B) Supplied with Reduction Bushing
Fornito con Bussola di Riduzione

B) Available on Request without reduction bushing
Disponibile a Richiesta senza Bussola di Riduzione

C) Motor Flange Holes Position
Posizione Fori Flangia Motore

EN Unit **P8M** is supplied with synthetic oil, providing "long life" lubrication. For mounting position V5-V6 please contact us. See table 1 for lubrication and recommended quantity. In table 2 please see possible radial loads and axial loads on the gearbox.

I Il riduttore tipo **P8M** viene fornito lubrificato a vita con olio sintetico. Per posizioni V5-V6 contattare il ns. servizio tecnico. Vedi tab.1 per oli e quantità consigliati. In tab.2 sono presenti i carichi radiali e assiali applicabili al riduttore.

D Für die Lebensdauerschmierung ist das Getriebe der Größe **P8M** mit synthetischem Öl befüllt. Bei Einbaulage V5 oder V6 bitten wir um Rücksprache. In Tabelle 1 ist die Schmiermenge und das empfohlene Schmiermittel angegeben. In Tabelle 2 sind die zulässigen Radial- und Axialbelastungen des Getriebes aufgeführt.

F Le réducteur de type **P8M** est fourni lubrifié à vie avec de l'huile synthétique. Concernant les positions V5.V6, contactez notre service d'assistance technique. Voir tableau 1 concernant les huiles et les quantités conseillées. Les charges radiales et axiales applicables au réducteur sont précisées dans le tableau 2.

E El reductor tamaño **P8M** se suministra, lubricado de por vida con aceite sintético. Para las posiciones V5 y V6 contactar con nuestro servicio técnico. Ver tabla 1, para cantidades y aceites recomendados. En la tabla 2, se encuentran las cargas radiales y axiales admitidas por el reductor.

LUBRICATION P8M Oil

For B3-V5-V6 separate lubrication for A (1.20 l) B (0.14 l) , for B6-B7-B8 common lubrication 1.00 l (A + B).

SHELL Omala S4 WE 320 **ENI** Telium VSF 320

For all details on lubrication and plugs check our website **tab. 1**
Per maggiori dettagli su lubrificazione e tappi olio vedi il nostro sito web

RADIAL AND AXIAL LOADS

Output shaft
Albero di uscita

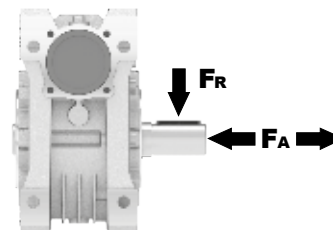

n_2 [min ⁻¹]	FA [N]	FR [N]
75	700	3500
50	800	4000
25	1000	5000
15-6	1160	5800

Input shaft
albero in entrata

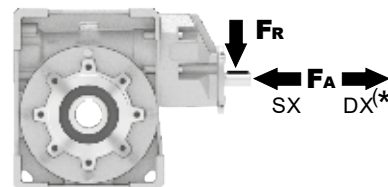

n_1 [min ⁻¹]	FA [N]	FR [N]
1400	108	540

*Strong axial loads in the DX direction are not allowed.
Non sono consentiti forti carichi assiali con direzione DX

tab. 2

PP8MFB... Basic wormbox
Riduttore base

M. flanges	Kit code	øF	A
63B5	K063.4.041	140	195.2
71B5	K063.4.042	160	193.2
80/90B5	K063.4.043	200	195.2
71B14	K063.4.047	105	193.2
80B14	K063.4.046	120	195.2
90B14	K063.4.041	140	195.2

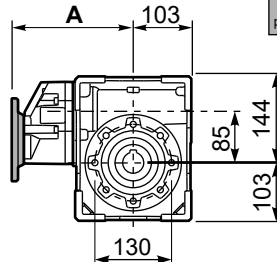
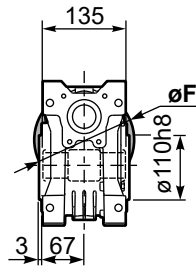

Gearbox weight
peso riduttore **12.3 kg**

ø H8	B	C	*Spacer code
35 Standard	38.3	10	KM85.3.035
38 on request	41.3	10	KM85.3.038

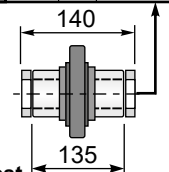
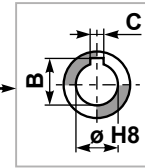

8 holes M10x18

*On Request
output shaft with spacers

PP8MFC... Output flange
Flangia uscita

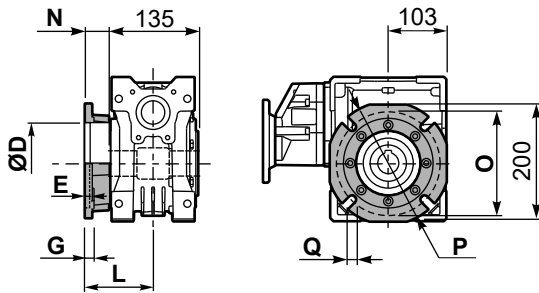

type B	øD	E	G	L	N	O	P	Q	kit code
FC	152 H8	5	16	111	43.5	176	205	13	K085.9.010
FL	180 H8	6	18	122	54.5	215	250	14	KM85.9.011

PP8MF1... Output flange
Flangia uscita

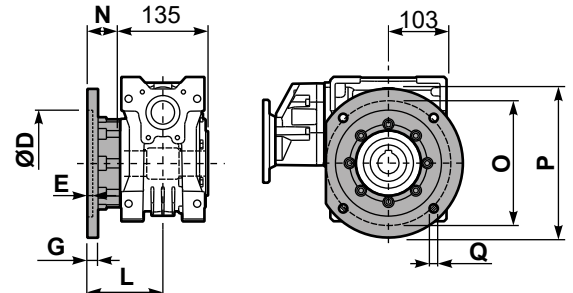

type S	øD	E	G	L	N	O	P	Q	kit code
F1	130 H8	5	13	109.5	42	165	200	13	KS085.9.015
F2	152 H8	5	16	151.5	84	176	205	13	K085.9.010 K085.0.201

PP8MFB... Feet
Piedini

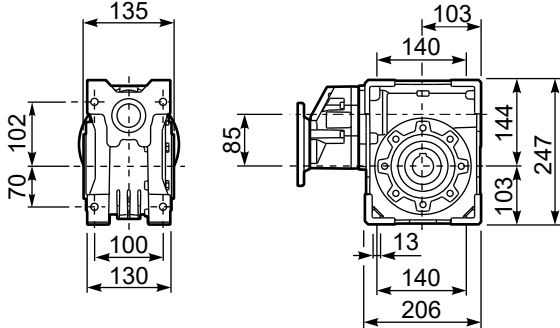

PP8MBR... Reaction arm
Braccio di reazione

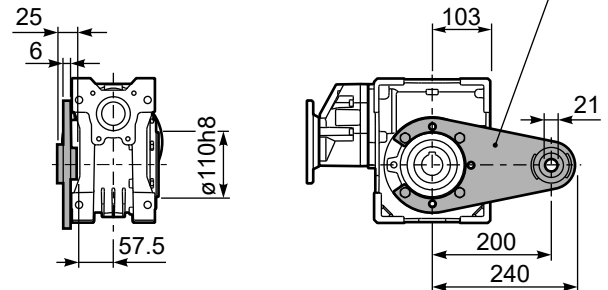

kit cod. K085.9.027

RP8MFB... Input shaft
Albero in entrata

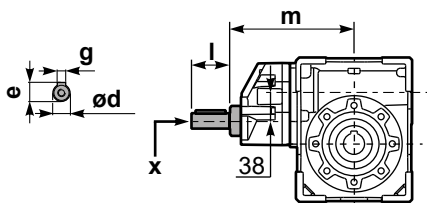

type B	ød	e	g	l	m	x
type B	19 h6	21.5	6	35	186	M6x16
type S	-	-	-	-	-	-

PP8M...S... Single Shaft
Albero lento semplice

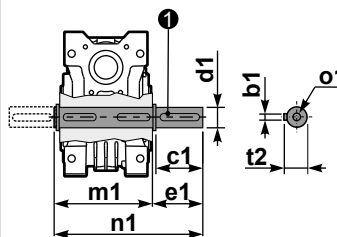

PP8M...D... Double Shaft
Albero lento bisp.

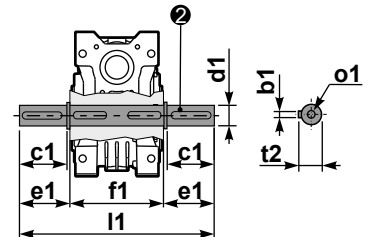

① kit cod. K085.5.028 type B

② kit cod. K085.5.029 type B

type B	b1	c1	d1	e1	f1	l1	m1	n1	t2	o1
type B	10	60	35 ^{-0.005} _{-0.020}	73.5	135	282	141	214.5	38	M10x23
type S	-	-	-	-	-	-	-	-	-	-

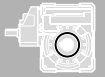

QUICK SELECTION / Selezione veloce

input speed (n_1) = 1400 min⁻¹

Output Speed n_2 [min ⁻¹]	Ratio i	Motor power P_{1M} [kW]	Output torque M_{2M} [Nm]	Service factor f.s.	Nominal power P_{1R} [kW]	Nominal torque M_{2R} [Nm]	Available B5 motor flanges				Available B14 motor flanges			Dynamic efficiency RD	Tooth Module [mm]	Ratios code
							-B	-C	-D	-E	-Q	-R	-T			
							63	71	80	90	71	80	90			
16.8	83.2	1.5	587	1.1	1.7	660					C	C		69	3.5	01
13.9	100.5	1.5	699	0.8	1.3	594					C	C		68	2.9	02
10.6	132	1.1	634	0.9	0.95	550					C	C		64	2.2	03
8.0	176	0.75	666	1.2	0.90	803	B				C	C		74	4.7	04
6.7	208	0.75	766	0.9	0.65	660	B				C	C		72	4.0	05
5.7	245	0.55	634	1.0	0.57	660	B				C	C		69	3.5	06
4.7	296	0.55	755	0.8	0.43	594	B				C	C		68	2.9	07
4.2	334	0.55	865	0.8	0.42	660	B				C	C		69	3.5	08
3.5	403	0.37	692	0.9	0.32	594	B				C	C		68	2.9	09
2.6	529	0.25	577	1.0	0.24	550	B				C	C		64	2.2	10
2.2	624	0.25	628	0.8	0.21	528	B				C	C		59	1.9	11

Motor Flanges Available
Flange Motore Disponibili

B) Supplied with Reduction Bushing
Fornito con Bussola di Riduzione

B) Available on Request without reduction bushing
Disponibile a Richiesta senza Bussola di Riduzione

C) Motor Flange Holes Position
Posizione Fori Flangia Motore

EN Unit **P1M** is supplied without lubricant and equipped with a breather, level and drain plugs. User can add mineral oil keeping existing plugs. Should the user wish to fill it with synthetic oil, it is recommended to replace the existing plugs with a closed plug. Primary reduction unit is supplied with closed plugs and lubricated for life with synthetic oil. See table 1 for lubrication and recommended quantity. In table 2 please see possible radial loads and axial loads on the gearbox.

I Il riduttore tipo **P1M** è fornito privo di lubrificazione con tappi di sfiato, livello e scarico olio. L'utente può immettere olio minerale mantenendo i tappi esistenti. Se immetterà olio sintetico, dovrà sostituire i tappi esistenti con altri tipo chiuso. La precoppia è fornita con tappi chiusi e lubrificata a vita con olio sintetico. Tab.1 per oli e quantità consigliati. Tab.2 carichi radiali e assiali applicabili al riduttore.

D Das Getriebe der Baugröße **P1M** wird ohne Schmiermittel geliefert. Es ist jedoch mit Einfüllschraube, Überdruckventil und Ablassschraube ausgerüstet. Das benötigte mineralische Öl kann über die Einfüllschraube eingefüllt werden. Sollte synthetisches Öl bevorzugt werden, so ist sind das eingebaute Überdruckventil durch eine geschlossenen Schraube zu ersetzen. Die Stirnradvorstufe ist Lebensdauergeschmiert und wird mit synthetischem Öl geliefert. Die Stirnradvorstufe ist komplett geschlossen ohne Füllschrauben. In Tabelle 1 ist die Schmiermenge und das empfohlene Schmiermittel angegeben. In Tabelle 2 sind die zulässigen Radial- und Axialbelastungen des Getriebes aufgeführt.

F Le réducteur de type **P1M** est fourni sans lubrification et avec un bouchon de remplissage, de niveau et d'évacuation de l'huile. L'utilisateur peut verser de l'huile minérale en conservant les bouchons existants. S'il y versera de l'huile synthétique, il devra substituer les bouchons existants avec d'autres bouchons de type fermé. Le pré couple est fourni lubrifié à vie avec de l'huile synthétique et avec des bouchons fermés. Voir tableau 1 concernant les huiles et les quantités conseillées. Voir tableau 2 concernant les charges radiales et axiales applicables au réducteur.

E El reductor tamaño **P1M** se suministra sin lubricante, provisto de tapones de respiración, nivel y descarga de aceite. El usuario puede utilizar aceite mineral, manteniendo los tapones existentes. Si prefiere utilizar aceite sintético deberá sustituir los tapones existentes por tapones ciegos. La prerreducción se suministra con tapones ciegos, lubricado de por vida con aceite sintético. Ver tabla 1, para cantidades y aceites recomendados. En la tabla 2, se encuentran las cargas radiales y axiales admitidas por el reductor.

B3	B6	B7	B8	V5	V6
1.9/0.14LT	1.35/0.14 LT	1.35/0.14 LT	2.0/0.14 LT	2.0/0.14 LT	2.0/0.14 LT
SHELL Omala S2 GX 460			ENI Blasias 460		

For all details on lubrication and plugs check our website **tab. 1**
Per maggiori dettagli su lubrificazione e tappi olio vedi il nostro sito web

RADIAL AND AXIAL LOADS

Output shaft

Albero di uscita

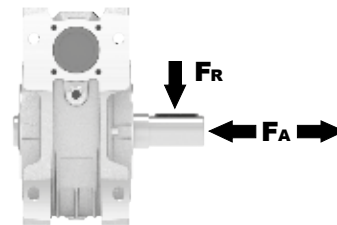

n_2 [min ⁻¹]	FA [N]	FR [N]
75	800	4000
50	920	4600
25	1200	6000
15-6	1400	7000

Input shaft

albero in entrata

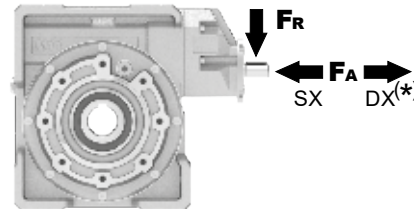

n_1 [min ⁻¹]	FA [N]	FR [N]
1400	150	760

***Strong axial loads in the DX direction are not allowed.**
Non sono consentiti forti carichi assiali con direzione DX

tab. 2

PP1M**FB**... Basic wormbox
Riduttore base

Gearbox weight
peso riduttore **37.3 kg**

M. flanges	Kit code	øF	A
63B5	K063.4.041	140	214.7
71B5	K063.4.042	160	212.7
80/90B5	K063.4.043	200	214.7
71B14	K063.4.047	105	212.7
80B14	K063.4.046	120	214.7
90B14	K063.4.041	140	214.7

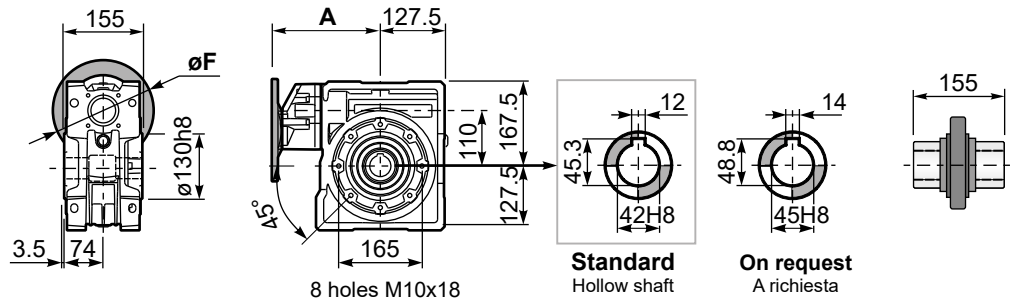

PP1M**FC**... Output flange
Flangia uscita

PP1M**FL**... Output flange
Flangia uscita

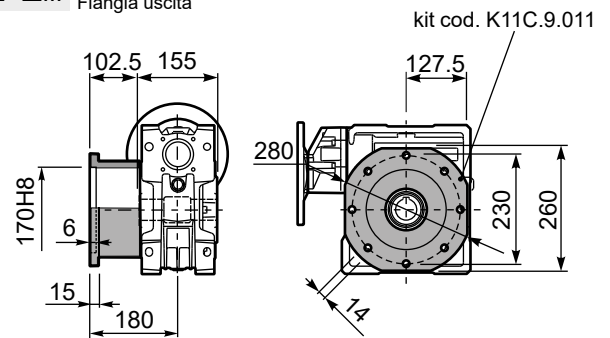
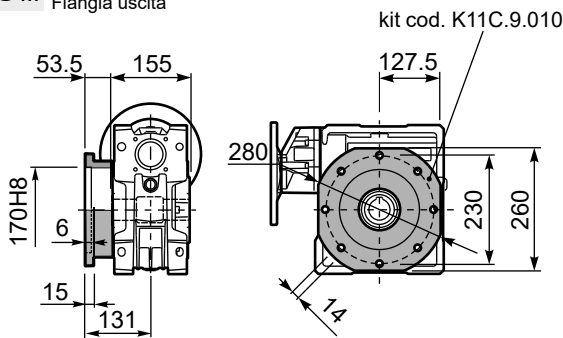

PP1M**FB**... Feet
Piedini

PP1M**BR**... Reaction arm
Braccio di reazione

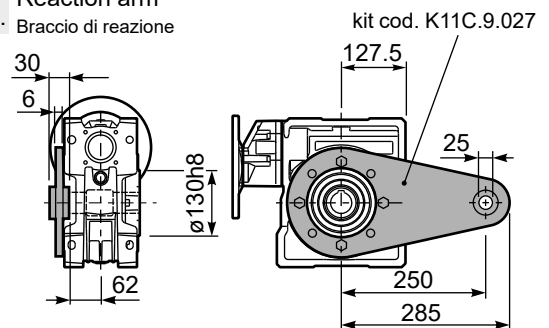
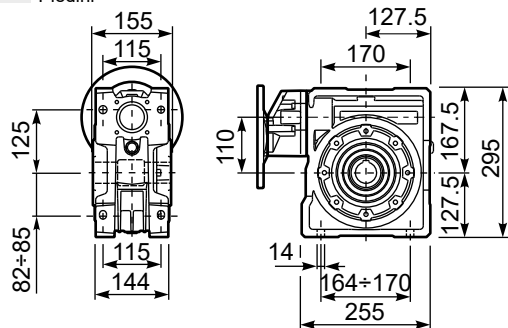

RP1M**FB**... Input shaft
Albero in entrata

PP1M...**S**... Single Shaft
Albero lento semplice

PP1M...**D**... Double Shaft
Albero lento bisp.

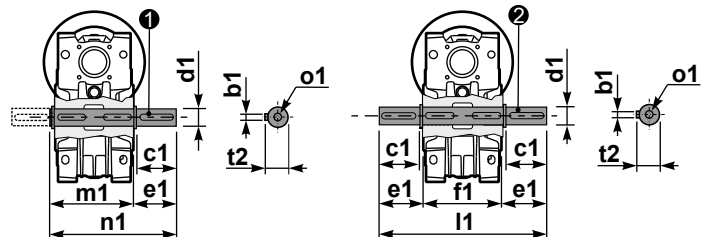
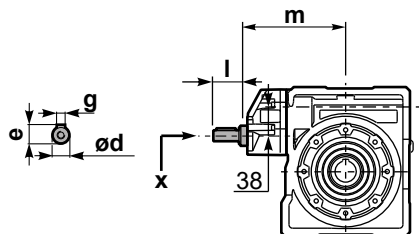

① kit cod. K11C.5.028 type B

② kit cod. K11C.5.029 type B

	ød	e	g	l	m	x	
type B	19 h6	21.5	6	35	205	M6x16	C40.5.062
type S	-	-	-	-	-	-	-

	b1	c1	d1	e1	f1	l1	m1	n1	t2	o1
type B	12	80	42h6	84.5	155	324	164.5	249	45	M16x28
type S	-	-	-	-	-	-	-	-	-	-

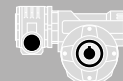

QUICK SELECTION / Selezione veloce

input speed (n_1) = 1400 min⁻¹

Output Speed n_2 [min ⁻¹]	Ratio i	Motor power P_{1M} [kW]	Output torque M_{2M} [Nm]	Service factor f.s.	Nominal power P_{1R} [kW]	Nominal torque M_{2R} [Nm]	Available B5 motor flanges		Available B14 motor flanges		Dynamic efficiency RD	Tooth Module [mm]	Ratios code
							-A	-B	-O	-P			
							56	63	56	63			
9.3	150	0.06	29	1.3	0.08	38	B		B-C		48	1.44	01
6.7	210	0.06	39	1.0	0.06	38	B		B-C		45	1.44	02
4.7	300	0.06	44	0.9	0.05	38	B		B-C		36	1.44	03
3.1	450	0.06*	38	<0.8	0.04	38	B		B-C		33	1.44	04
2.3	600	0.06*	38	<0.8	0.03	38	B		B-C		30	1.44	05
1.6	900	0.06*	38	<0.8	0.02	38	B		B-C		27	1.44	06
1.2	1200	0.06*	38	<0.8	0.02	38	B		B-C		26	1.44	07
0.8	1830	0.06*	38	<0.8	0.01	38	B		B-C		24	1.44	08
0.6	2400	0.06*	38	<0.8	0.01	38	B		B-C		22	1.44	09

A) Motor Flanges Available
Flange Motore Disponibili

B) Supplied with Reduction Bushing
Fornito con Bussola di Riduzione

B) Available on Request without reduction bushing
Disponibile a Richiesta senza Bussola di Riduzione

C) Motor Flange Holes Position
Posizione Fori Flangia Motore

* Power higher than the maximum one which can be supported by the gearbox. Select according to the torque M_{2R}
Potenza superiore a quella massima sopportabile dal riduttore. Selezionare in base al momento torcente M_{2R}

EN Unit **33M** is supplied with synthetic oil, providing "long life" lubrication. For mounting position V5-V6 please contact us. See table 1 for lubrication and recommended quantity. In table 2 please see possible radial loads and axial loads on the gearbox.

I Il riduttore tipo **33M** viene fornito lubrificato a vita con olio sintetico. Per posizioni V5-V6 contattare il ns. servizio tecnico. Vedi tab.1 per oli e quantità consigliati. In tab.2 sono presenti i carichi radiali e assiali applicabili al riduttore.

D Für die Lebensdauerschmierung ist das Getriebe der Größe **33M** mit synthetischem Öl befüllt. Bei Einbaulage V5 oder V6 bitten wir um Rücksprache. In Tabelle 1 ist die Schmiermenge und das empfohlene Schmiermittel angegeben. In Tabelle 2 sind die zulässigen Radial- und Axialbelastungen des Getriebes aufgeführt.

F Le réducteur de type **33M** est fourni lubrifié à vie avec de l'huile synthétique. Concernant les positions V5.V6, contactez notre service d'assistance technique. Voir tableau 1 concernant les huiles et les quantités conseillées. Les charges radiales et axiales applicables au réducteur sont précisées dans le tableau 2.

E El reductor tamaño **33M** se suministra, lubricado de por vida con aceite sintético. Para las posiciones V5 y V6 contactar con nuestro servicio técnico. Ver tabla 1, para cantidades y aceites recomendados. En la tabla 2, se encuentran las cargas radiales y axiales admitidas por el reductor.

LUBRICATION 33M Oil 0.03 Lt.
Quantity 0.03/0.03 Lt.

SHELL Omala S4 WE 320 **ENI** Telium VSF 320

For all details on lubrication and plugs check our website **tab. 1**
Per maggiori dettagli su lubrificazione e tappi olio vedi il nostro sito web

RADIAL AND AXIAL LOADS

Output shaft
Albero di uscita

n_2 [min ⁻¹]	FA [N]	FR [N]
25	300	1800
15	400	2000

Input shaft
albero in entrata

n_1 [min ⁻¹]	FA [N]	FR [N]
1400	20	100

***Strong axial loads in the DX direction are not allowed.**
Non sono consentiti forti carichi assiali con direzione DX

tab. 2

P33MFB... Basic wormbox
Riduttore base

Gearbox weight
peso riduttore **2.25 kg**

M. flanges	Kit code	øF	A
56B5	K030.4.041	120	61.5
63B5	K030.4.042	140	62.5
56B14	K030.4.046	80	61.5
63B14	K030.4.045	90	62.5

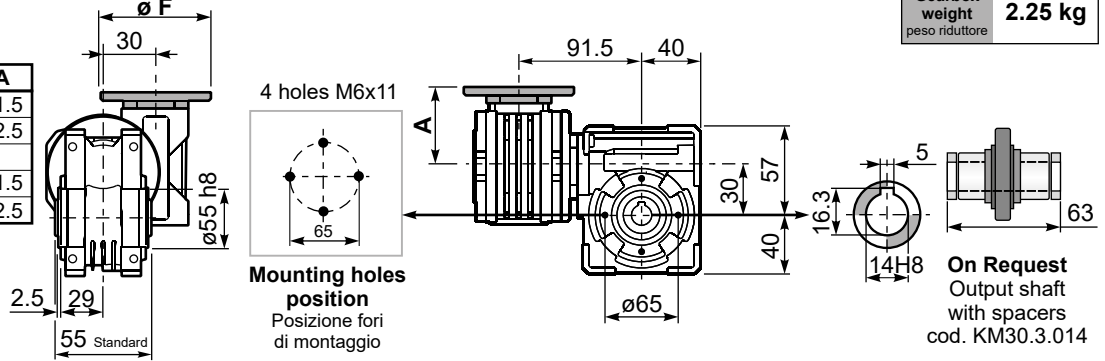

P33MFC... Square flange
Flangia quadrata

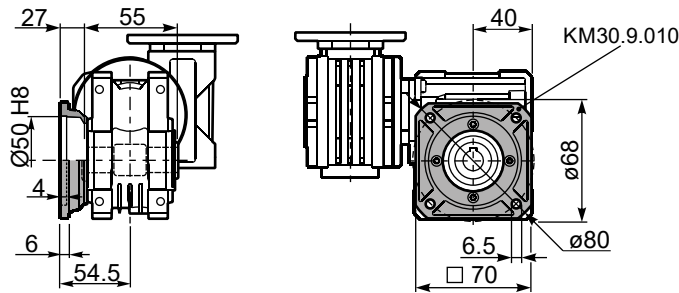

P33MFB... Feet
Piedini

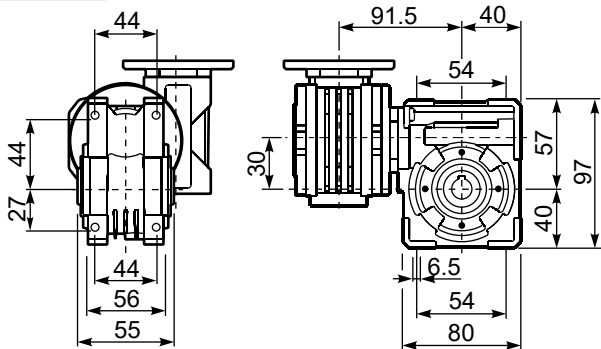

P33MBR... Reaction arm
Braccio di reazione

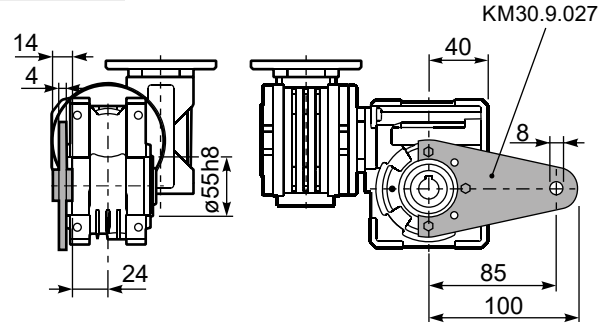

R33MFB... Input shaft
Albero in entrata

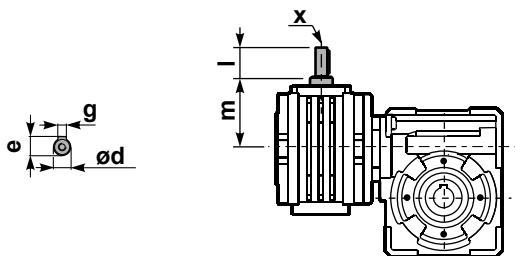

P33M....S... Single Shaft
Albero lento semplice

P33M....D... Double Shaft
Albero lento bisp.

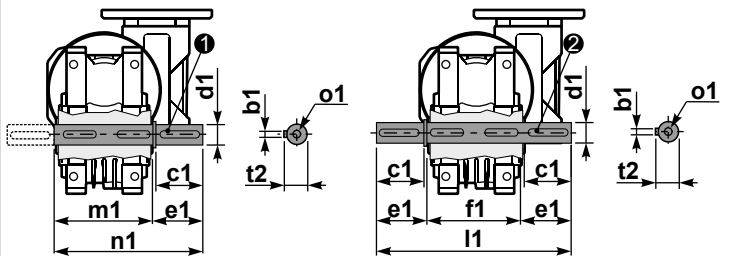

① kit cod. K030.5.028 type B

② kit cod. K030.5.029 type B

	ød	e	g	l	m	x	kit code
type B	9 h6	10.2	3	20	58	-	K030.5.006 PAM63
type S	-	-	-	-	-	-	-

	b1	c1	d1	e1	f1	l1	m1	n1	t2	o1
type B	5	25	14 ^{-0.005} _{-0.020}	35.5	55	126	59	94.5	16	M5x14
type S	-	-	-	-	-	-	-	-	-	-

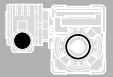

QUICK SELECTION / Selezione veloce

input speed (n_1) = 1400 min⁻¹

Output Speed n_2 [min ⁻¹]	Ratio i	Motor power P_{1M} [kW]	Output torque M_{2M} [Nm]	Service factor f.s.	Nominal power P_{1R} [kW]	Nominal torque M_{2R} [Nm]	Available B5 motor flanges		Available B14 motor flanges		Dynamic efficiency RD	Tooth Module [mm]	Ratios code
							-A	-B	-O	-P			
10.0	140	0.12	57	1.3	0.15	72	B		B-C		50	2.2	01
7.0	200	0.12	79	0.9	0.11	72	B		B-C		48	2.2	02
5.0	280	0.09	77	0.9	0.08	72	B		B-C		45	2.4	03
3.3	420	0.06	62	1.2	0.07	72	B		B-C		36	1.6	04
2.5	560	0.06	76	1.0	0.06	72	B		B-C		33	2.5	05
1.9	740	0.06	91	0.8	0.05	72	B		B-C		30	1.8	06
1.5	920	0.06*	72	<0.8	0.04	72	B		B-C		27	1.5	07
1.3	1120	0.06*	72	<0.8	0.04	72	B		B-C		26	2.5	08
0.9	1480	0.06*	72	<0.8	0.03	72	B		B-C		24	1.8	09
0.8	1840	0.06*	72	<0.8	0.03	72	B		B-C		22	1.5	10
0.6	2400	0.06*	72	<0.8	0.02	72	B		B-C		21	1.2	11

Motor Flanges Available
Flange Motore Disponibili

B) Supplied with Reduction Bushing
Fornito con Bussola di Riduzione

B) Available on Request without reduction bushing
Disponibile a Richiesta senza Bussola di Riduzione

C) Motor Flange Holes Position
Posizione Fori Flangia Motore

* Power higher than the maximum one which can be supported by the gearbox. Select according to the torque M_{2R}
Potenza superiore a quella massima sopportabile dal riduttore. Selezionare in base al momento torcente M_{2R}

EN Unit **43M** is supplied with synthetic oil, providing "long life" lubrication. For mounting position V5-V6 please contact us. See table 1 for lubrication and recommended quantity. In table 2 please see possible radial loads and axial loads on the gearbox.

I Il riduttore tipo **43M** viene fornito lubrificato a vita con olio sintetico. Per posizioni V5-V6 contattare il ns. servizio tecnico. Vedi tab.1 per oli e quantità consigliati. In tab.2 sono presenti i carichi radiali e assiali applicabili al riduttore.

D Für die Lebensdauerschmierung ist das Getriebe der Größe **43M** mit synthetischem Öl befüllt. Bei Einbaulage V5 oder V6 bitten wir um Rücksprache. In Tabelle 1 ist die Schmiermenge und das empfohlene Schmiermittel angegeben. In Tabelle 2 sind die zulässigen Radial- und Axialbelastungen des Getriebes aufgeführt.

F Le réducteur de type **43M** est fourni lubrifié à vie avec de l'huile synthétique. Concernant les positions V5.V6, contactez notre service d'assistance technique. Voir tableau 1 concernant les huiles et les quantités conseillées. Les charges radiales et axiales applicables au réducteur sont précisées dans le tableau 2.

E El reductor tamaño **43M** se suministra, lubricado de por vida con aceite sintético. Para las posiciones V5 y V6 contactar con nuestro servicio técnico. Ver tabla 1, para cantidades y aceites recomendados. En la tabla 2, se encuentran las cargas radiales y axiales admitidas por el reductor.

0.09 Lt.

0.03 Lt.

LUBRICATION 43M Oil
Quantity 0.09/0.03 Lt.

SHELL Omala S4 WE 320	ENI Telium VSF 320
------------------------------	---------------------------

For all details on lubrication and plugs check our website **tab. 1**
Per maggiori dettagli su lubrificazione e tappi olio vedi il nostro sito web

RADIAL AND AXIAL LOADS

Output shaft
Albero di uscita

n_2 [min ⁻¹]	FA [N]	FR [N]
25	300	1800
15	400	2000

Input shaft
albero in entrata

n_1 [min ⁻¹]	FA [N]	FR [N]
1400	20	100

*Strong axial loads in the DX direction are not allowed.
Non sono consentiti forti carichi assiali con direzione DX

tab. 2

P43MFB... Basic wormbox
Riduttore base

M. flanges	Kit code	øF	A
56B5	K030.4.041	120	61.5
63B5	K030.4.042	140	62.5
56B14	K030.4.046	80	61.5
63B14	K030.4.045	90	62.5

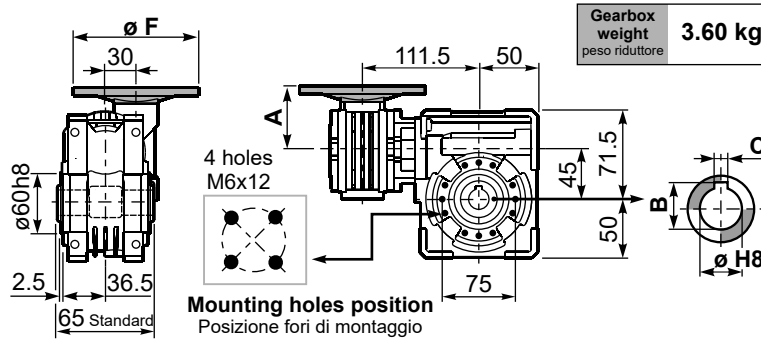

Gearbox weight
peso riduttore **3.60 kg**

ø H8	B	C	*Spacer code
18 Standard	20.8	6	KM45.3.018
19 on request	21.8	6	KM45.3.019
20 on request	22.8	6	KM45.3.020

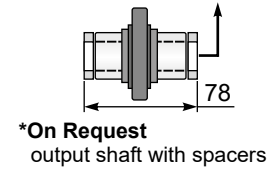

P43MFC... Square flange
Flangia quadrata

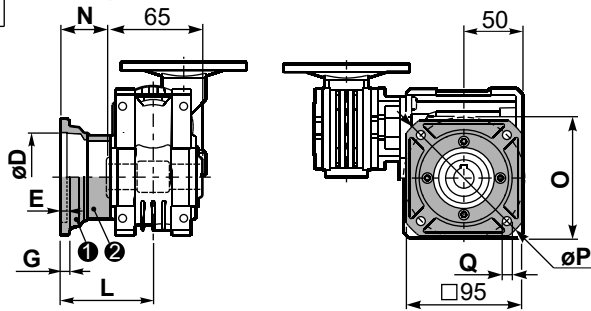

type B	øD	E	G	L	N	O	P	Q	kit code
FC	60 H8	4	7	67	34.5	75	110	9	KM45.9.010
FL	60 H8	4	7	97	64.5	75	110	9	KM45.9.011

P43MF1... Round flange
Flangia rotonda

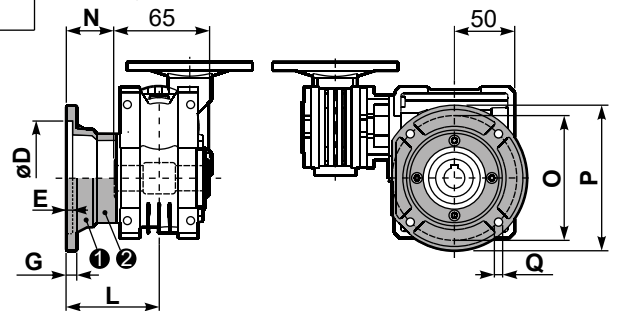

type S	øD	E	G	L	N	O	P	Q	kit code
F1	95H8	5	9	80	47.5	115	140	9.5	KM45.9.012
F2	-	-	-	-	-	-	-	-	-

P43MFB... Feet
Piedini

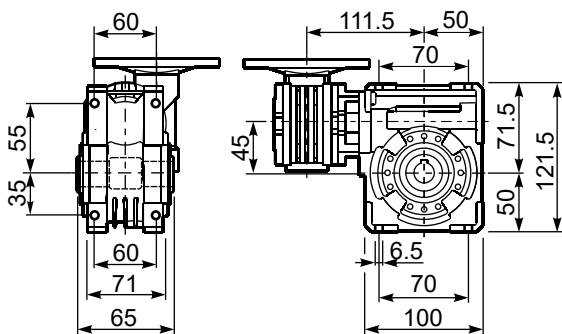

P43MBR... Reaction arm
Braccio di reazione

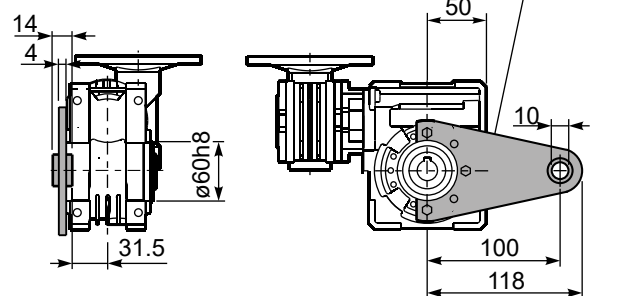

kit cod. KM45.9.027

R43MFB... Input shaft
Albero in entrata

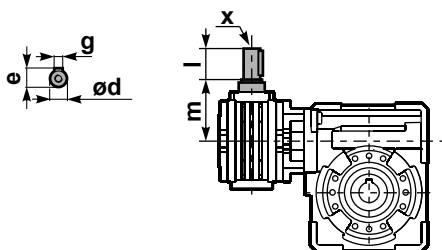

	ød	e	g	l	m	x	kit code
type B	9 h6	10.2	3	20	58	-	K030.5.006 PAM63
type S	-	-	-	-	-	-	-

P43M.....S... Single Shaft
Albero lento semplice

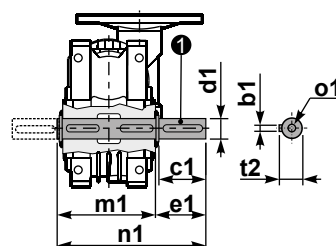

① kit cod. K045.5.028 type B
kit cod. KS045.5.030 type S

P43M.....D... Double Shaft
Albero lento bisp.

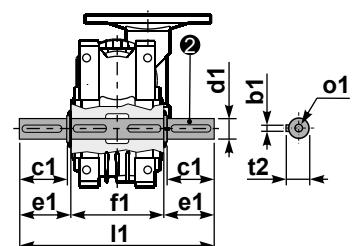

② kit cod. K045.5.029 type B

	b1	c1	d1	e1	f1	l1	m1	n1	t2	o1
type B	6	32	18 ^{-0.005} _{-0.020}	43	65	151	70	113	20.5	M6x18
type S	6	40	19 ^{-0.005} _{-0.020}	58.5	-	-	70	128.5	21.5	M8x20

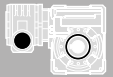

QUICK SELECTION / Selezione veloce

input speed (n_1) = 1400 min⁻¹

Output Speed n_2 [min ⁻¹]	Ratio i	Motor power P_{1M} [kW]	Output torque M_{2M} [Nm]	Service factor f.s.	Nominal power P_{1R} [kW]	Nominal torque M_{2R} [Nm]	Available B5 motor flanges		Available B14 motor flanges		Dynamic efficiency RD	Tooth Module [mm]	Ratios code
							-A	-B	-O	-P			
							56	63	56	63			
5.6	252	0.12	97	1.4	0.17	138	B		B-C		47	2.1	01
3.9	360	0.12	124	1.1	0.13	138	B		B-C		42	2.1	02
2.6	540	0.09	129	1.1	0.10	138	B		B-C		39	2.1	03
1.9	720	0.09	159	0.9	0.08	138	B		B-C		36	2.1	04
1.6	860	0.06	113	1.2	0.07	138	B		B-C		32	1.8	05
1.2	1200	0.06	133	1.0	0.06	138	B		B-C		27	1.3	06
1.0	1440	0.06	153	0.9	0.05	138	B		B-C		26	2.1	07
0.8	1720	0.06	176	0.8	0.05	138	B		B-C		25	1.8	08
0.6	2400	0.06*	132	<0.8	0.04	132	B		B-C		21	1.3	09

A) Motor Flanges Available
Flange Motore Disponibili

B) Supplied with Reduction Bushing
Fornito con Bussola di Riduzione

B) Available on Request without reduction bushing
Disponibile a Richiesta senza Bussola di Riduzione

C) Motor Flange Holes Position
Posizione Fori Flangia Motore

* Power higher than the maximum one which can be supported by the gearbox. Select according to the torque M_{2R}
Potenza superiore a quella massima sopportabile dal riduttore. Selezionare in base al momento torcente M_{2R}

EN Unit **53M** is supplied with synthetic oil, providing "long life" lubrication. For mounting position V5-V6 please contact us.
See table 1 for lubrication and recommended quantity. In table 2 please see possible radial loads and axial loads on the gearbox.

I Il riduttore tipo **53M** viene fornito lubrificato a vita con olio sintetico. Per posizioni V5-V6 contattare il ns. servizio tecnico.
Vedi tab.1 per oli e quantità consigliati. In tab.2 sono presenti i carichi radiali e assiali applicabili al riduttore.

D Für die Lebensdauerschmierung ist das Getriebe der Größe **53M** mit synthetischem Öl befüllt. Bei Einbaulage V5 oder V6 bitten wir um Rücksprache. In Tabelle 1 ist die Schmiermenge und das empfohlene Schmiermittel angegeben. In Tabelle 2 sind die zulässigen Radial- und Axialbelastungen des Getriebes aufgeführt.

F Le réducteur de type **53M** est fourni lubrifié à vie avec de l'huile synthétique. Concernant les positions V5.V6, contactez notre service d'assistance technique. Voir tableau 1 concernant les huiles et les quantités conseillées. Les charges radiales et axiales applicables au réducteur sont précisées dans le tableau 2.

E El reductor tamaño **53M** se suministra, lubricado de por vida con aceite sintético. Para las posiciones V5 y V6 contactar con nuestro servicio técnico. Ver tabla 1, para cantidades y aceites recomendados. En la tabla 2, se encuentran las cargas radiales y axiales admitidas por el reductor.

LUBRICATION 53M Oil
Quantity 0.14/0.03 Lt.

0.14 Lt.

0.03 Lt.

SHELL Omala S4 WE 320	ENI Telium VSF 320
------------------------------	---------------------------

For all details on lubrication and plugs check our website **tab. 1**
Per maggiori dettagli su lubrificazione e tappi olio vedi il nostro sito web

RADIAL AND AXIAL LOADS

Output shaft
Albero di uscita

n_2 [min ⁻¹]	FA [N]	FR [N]
25	480	2500
15	560	2800

Input shaft
albero in entrata

n_1 [min ⁻¹]	FA [N]	FR [N]
1400	20	100

*Strong axial loads in the DX direction are not allowed.
Non sono consentiti forti carichi assiali con direzione DX

tab. 2

P53MFB... Basic wormbox
Riduttore base

M. flanges	Kit code	øF	A
56B5	K030.4.041	120	61.5
63B5	K030.4.042	140	62.5
56B14	K030.4.046	80	61.5
63B14	K030.4.045	90	62.5

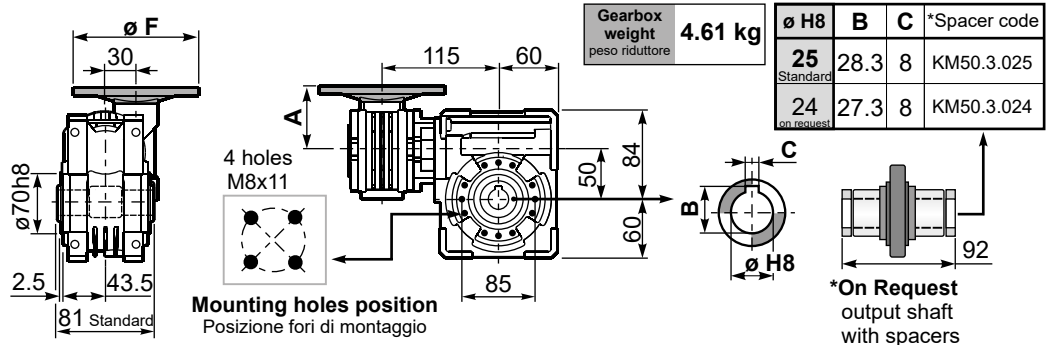

P53MFC... Square flange
Flangia quadrata

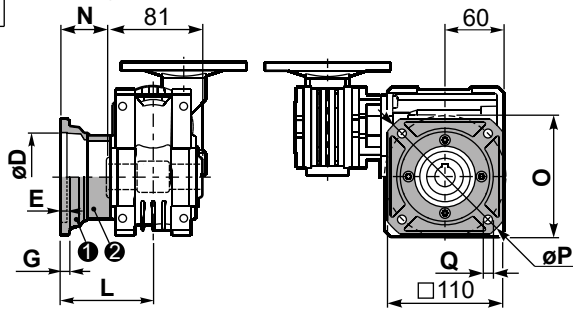

type B	øD	E	G	L	N	O	P	Q	kit code
FC	70 H8	5	9	90	49.5	85	125	11	KM50.9.010
FL	70 H8	5	9	120	79.5	85	125	11	KM50.9.011

P53MF1... Round flange
Flangia rotonda

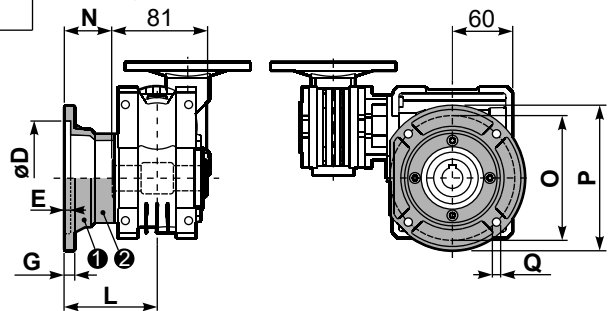

type S	øD	E	G	L	N	O	P	Q	kit code
F1	110 H8	5	10	89	48.5	130	160	9.5	KM50.9.012
F2	95 H8	5	14.5	72	31.5	115	140	11	KM50.9.013

P53MFB... Feet
Piedini

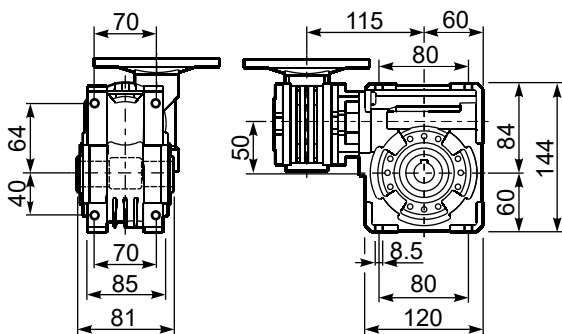

P53MBR... Reaction arm
Braccio di reazione

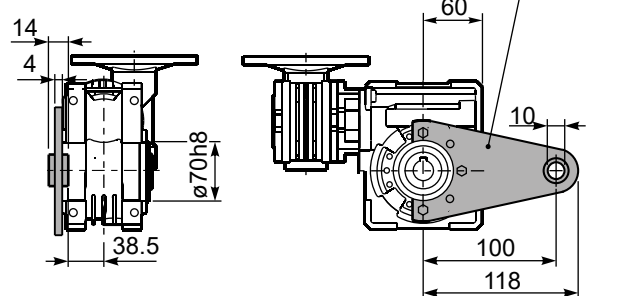

R53MFB... Input shaft
Albero in entrata

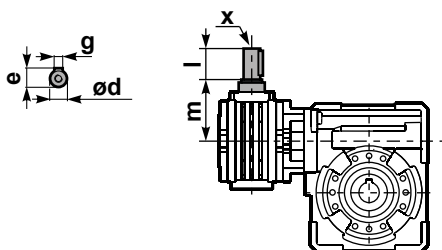

	ød	e	g	l	m	x	kit code
type B	9 h6	10.2	3	20	58	-	K030.5.006 PAM63
type S	-	-	-	-	-	-	-

P53M.....S... Single Shaft
Albero lento semplice

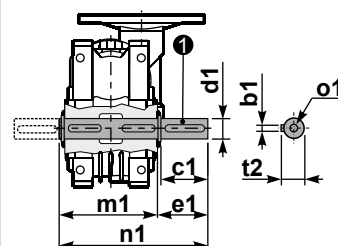

① kit cod. K050.5.028 type B
kit cod. KS050.5.030 type S

P53M.....D... Double Shaft
Albero lento bisp.

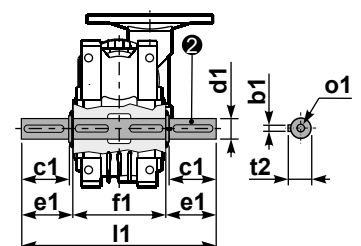

② kit cod. K050.5.029 type B

	b1	c1	d1	e1	f1	l1	m1	n1	t2	o1
type B	8	52	25 ^{-0.005} _{-0.020}	59.5	81	200	86.5	146	28	M8x20
type S	8	50	24 ^{-0.005} _{-0.020}	68.8	-	-	86.5	155	27	M8x20

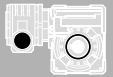

QUICK SELECTION / Selezione veloce

input speed (n_1) = 1400 min⁻¹

Output Speed n_2 [min ⁻¹]	Ratio i	Motor power P_{1M} [kW]	Output torque M_{2M} [Nm]	Service factor f.s.	Nominal power P_{1R} [kW]	Nominal torque M_{2R} [Nm]	Available B5 motor flanges		Available B14 motor flanges		Dynamic efficiency RD	Tooth Module [mm]	Ratios code
							-A	-B	-O	-P			
							56	63	56	63			
5.6	252	0.18	142	1.9	0.34	270	B		B-C		46	2.7	01
3.9	360	0.18	181	1.5	0.27	270	B		B-C		41	2.7	02
2.6	540	0.18	245	1.1	0.20	270	B		B-C		37	2.7	03
1.9	720	0.12	200	1.3	0.16	270	B		B-C		34	2.7	04
1.3	1080	0.12	265	1.0	0.12	270	B		B-C		30	2.7	05
1.0	1440	0.09	239	1.1	0.10	270	B		B-C		27	2.7	06
0.5	2745	0.06	258	1.0	0.06	270	B		B-C		23	2.1	07

A) Motor Flanges Available
Flange Motore Disponibili

B) Supplied with Reduction Bushing
Fornito con Bussola di Riduzione

B) Available on Request without reduction bushing
Disponibile a Richiesta senza Bussola di Riduzione

C) Motor Flange Holes Position
Posizione Fori Flangia Motore

* Power higher than the maximum one which can be supported by the gearbox. Select according to the torque M_{2R}
Potenza superiore a quella massima sopportabile dal riduttore. Selezionare in base al momento torcente M_{2R}

EN Unit **63M** is supplied with synthetic oil, providing "long life" lubrication. For mounting position V5-V6 please contact us. See table 1 for lubrication and recommended quantity. In table 2 please see possible radial loads and axial loads on the gearbox.

I Il riduttore tipo **63M** viene fornito lubrificato a vita con olio sintetico. Per posizioni V5-V6 contattare il ns. servizio tecnico. Vedi tab.1 per oli e quantità consigliati. In tab.2 sono presenti i carichi radiali e assiali applicabili al riduttore.

D Für die Lebensdauerschmierung ist das Getriebe der Größe **63M** mit synthetischem Öl befüllt. Bei Einbaulage V5 oder V6 bitten wir um Rücksprache. In Tabelle 1 ist die Schmiermenge und das empfohlene Schmiermittel angegeben. In Tabelle 2 sind die zulässigen Radial- und Axialbelastungen des Getriebes aufgeführt.

F Le réducteur de type **63M** est fourni lubrifié à vie avec de l'huile synthétique. Concernant les positions V5.V6, contactez notre service d'assistance technique. Voir tableau 1 concernant les huiles et les quantités conseillées. Les charges radiales et axiales applicables au réducteur sont précisées dans le tableau 2.

E El reductor tamaño **63M** se suministra, lubricado de por vida con aceite sintético. Para las posiciones V5 y V6 contactar con nuestro servicio técnico. Ver tabla 1, para cantidades y aceites recomendados. En la tabla 2, se encuentran las cargas radiales y axiales admitidas por el reductor.

0.30 Lt.

LUBRICATION 63M Oil
Quantity 0.30/0.03 Lt.

0.03 Lt.

SHELL Omala S4 WE 320	ENI Telium VSF 320
------------------------------	---------------------------

For all details on lubrication and plugs check our website **tab. 1**
Per maggiori dettagli su lubrificazione e tappi olio vedi il nostro sito web

RADIAL AND AXIAL LOADS

Output shaft
Albero di uscita

n_2 [min ⁻¹]	FA [N]	FR [N]
25	700	3800
15	800	4000

Input shaft
albero in entrata

n_1 [min ⁻¹]	FA [N]	FR [N]
1400	20	100

*Strong axial loads in the DX direction are not allowed.
Non sono consentiti forti carichi assiali con direzione DX

tab. 2

P63MFB... Basic wormbox
Riduttore base

Gearbox weight
peso riduttore **7.25 kg**

M. flanges	Kit code	øF	A
56B5	K030.4.041	120	61.5
63B5	K030.4.042	140	62.5
56B14	K030.4.046	80	61.5
63B14	K030.4.045	90	62.5

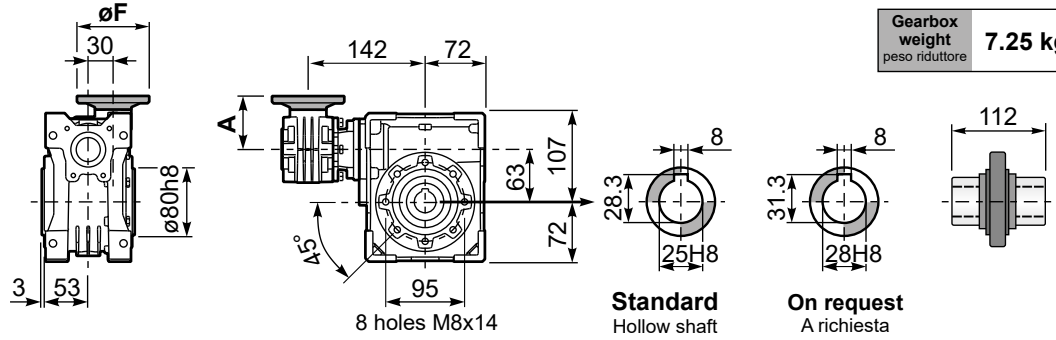

P63MFC... Square flange
Flangia quadrata

P63MF1... Round flange
Flangia rotonda

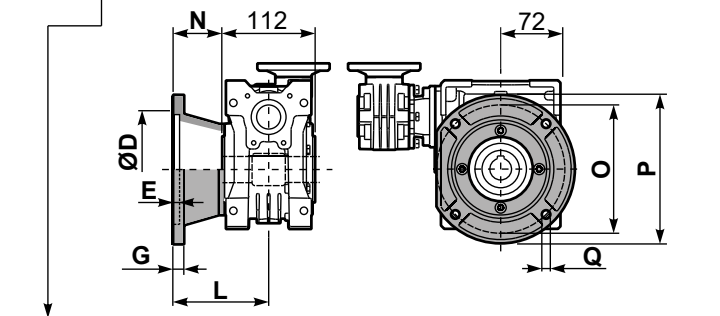
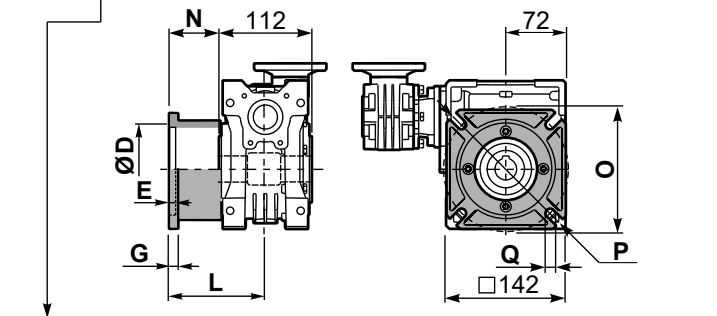

type B	øD	E	G	L	N	O	P	Q	kit code
FC	115 H8	6	10	82	26	150	180	11	KM63.9.010
FL	115 H8	6	10	112	56	150	180	11	KM63.9.011

type S	øD	E	G	L	N	O	P	Q	kit code
F1	130 H8	5	10	98	42	165	200	11	KM63.9.012
F2	130 H8	5	10	107	51	165	200	11	KM63.9.013
F3	110 H8	5	16.5	80.5	24.5	130	160	11	KM63.9.014

P63MFB... Feet
Piedini

P63MBR... Reaction arm
Braccio di reazione

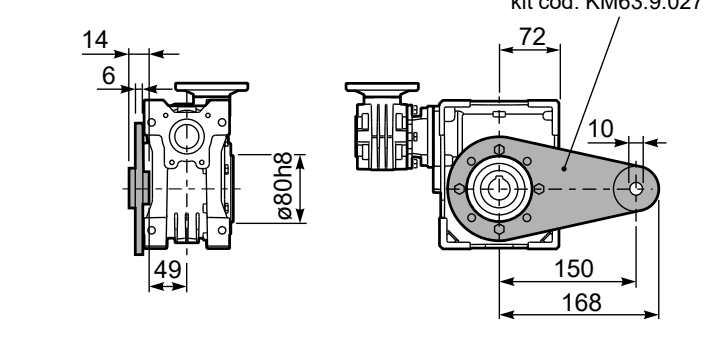
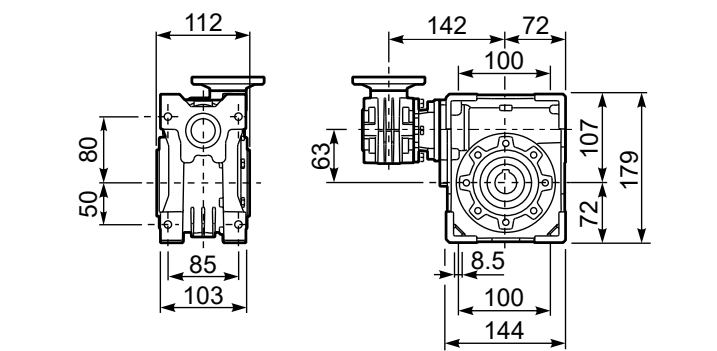

R63MFB... Input shaft
Albero in entrata

P63M....S... Single Shaft
Albero lento semplice

P63M....D... Double Shaft
Albero lento bisp.

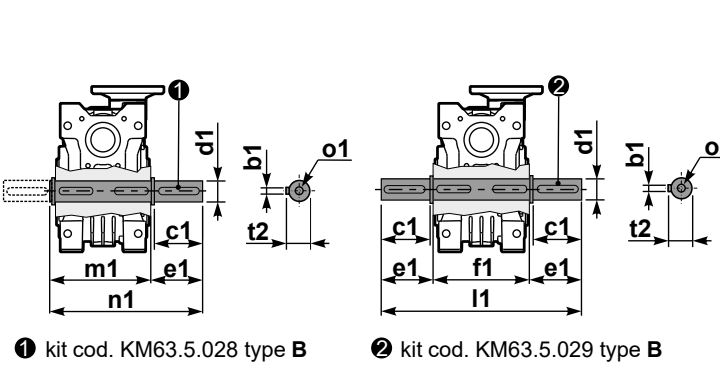
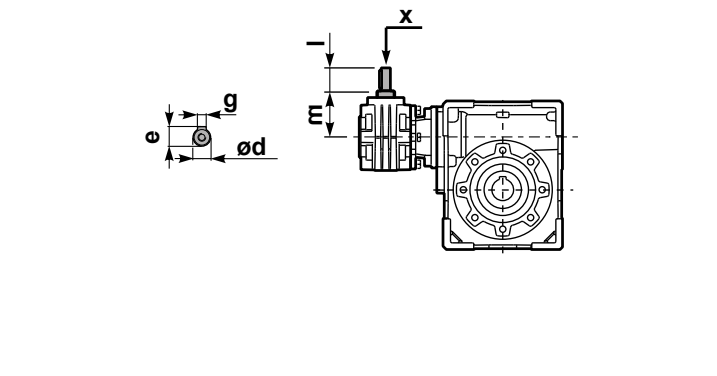

	ød	e	g	l	m	x	kit code
type B	9 h6	10.2	3	20	58	-	K030.5.006 PAM63
type S	-	-	-	-	-	-	-

	b1	c1	d1	e1	f1	l1	m1	n1	t2	o1
type B	8	50	25h6	53.5	112	219	119.5	173	28	M10x23
type S	-	-	-	-	-	-	-	-	-	-

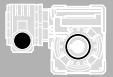

QUICK SELECTION / Selezione veloce

input speed (n_1) = 1400 min⁻¹

Output Speed n_2 [min ⁻¹]	Ratio i	Motor power P_{1M} [kW]	Output torque M_{2M} [Nm]	Service factor f.s.	Nominal power P_{1R} [kW]	Nominal torque M_{2R} [Nm]	Available B5 motor flanges		Available B14 motor flanges			Dynamic efficiency RD	Tooth Module $[mm]$	Ratios code
							-B	-C	-O	-P	-Q			
5.6	252	0.25	198	1.5	0.37	290	B		B-C	B-C		46	2.7	01
3.9	360	0.25	258	1.1	0.28	290	B		B-C	B-C		42	2.7	02
2.8	504	0.18	241	1.2	0.22	290	B		B-C	B-C		39	2.7	03
1.9	756	0.18	306	0.9	0.17	290	B		B-C	B-C		33	2.7	04
1.4	1008	0.12	256	1.1	0.14	290	B		B-C	B-C		31	2.7	05
1.1	1332	0.12	327	0.9	0.11	290	B		B-C	B-C		30	2.7	06
0.8	1656	0.09	285	1.0	0.09	290	B		B-C	B-C		28	2.7	07
0.6	2160	0.06	230	1.3	0.08	290	B		B-C	B-C		26	2.7	08
0.6	2520	0.06	258	1.1	0.07	290	B		B-C	B-C		25	2.7	09

A) Motor Flanges Available
Flange Motore Disponibili

B) Supplied with Reduction Bushing
Fornito con Bussola di Riduzione

B) Available on Request without reduction bushing
Disponibile a Richiesta senza Bussola di Riduzione

C) Motor Flange Holes Position
Posizione Fori Flangia Motore

* Power higher than the maximum one which can be supported by the gearbox. Select according to the torque M_{2R}
Potenza superiore a quella massima sopportabile dal riduttore. Selezionare in base al momento torcente M_{2R}

EN Unit **64M** is supplied with synthetic oil, providing "long life" lubrication. For mounting position V5-V6 please contact us. See table 1 for lubrication and recommended quantity. In table 2 please see possible radial loads and axial loads on the gearbox.

I Il riduttore tipo **64M** viene fornito lubrificato a vita con olio sintetico. Per posizioni V5-V6 contattare il ns. servizio tecnico. Vedi tab.1 per oli e quantità consigliati. In tab.2 sono presenti i carichi radiali e assiali applicabili al riduttore.

D Für die Lebensdauerschmierung ist das Getriebe der Größe **64M** mit synthetischem Öl befüllt. Bei Einbaulage V5 oder V6 bitten wir um Rücksprache. In Tabelle 1 ist die Schmiermenge und das empfohlene Schmiermittel angegeben. In Tabelle 2 sind die zulässigen Radial- und Axialbelastungen des Getriebes aufgeführt.

F Le réducteur de type **64M** est fourni lubrifié à vie avec de l'huile synthétique. Concernant les positions V5.V6, contactez notre service d'assistance technique. Voir tableau 1 concernant les huiles et les quantités conseillées. Les charges radiales et axiales applicables au réducteur sont précisées dans le tableau 2.

E El reductor tamaño **64M** se suministra, lubricado de por vida con aceite sintético. Para las posiciones V5 y V6 contactar con nuestro servicio técnico. Ver tabla 1, para cantidades y aceites recomendados. En la tabla 2, se encuentran las cargas radiales y axiales admitidas por el reductor.

LUBRICATION 64M Oil
Quantity 0.30/0.09 Lt.

0.30 Lt.

0.09 Lt.

SHELL Omala S4 WE 320	ENI Telium VSF 320
------------------------------	---------------------------

For all details on lubrication and plugs check our website **tab. 1**
Per maggiori dettagli su lubrificazione e tappi olio vedi il nostro sito web

RADIAL AND AXIAL LOADS

Output shaft
Albero di uscita

n_2 [min ⁻¹]	FA [N]	FR [N]
25	700	3800
15	800	4000

Input shaft
albero in entrata

n_1 [min ⁻¹]	FA [N]	FR [N]
1400	42	210

*Strong axial loads in the DX direction are not allowed.
Non sono consentiti forti carichi assiali con direzione DX

tab. 2

P64MFB... Basic wormbox
Riduttore base

Gearbox weight
peso riduttore **7.25 kg**

M. flanges	Kit code	øF	A
63B5	K050.4.041	138	74
71B5	K050.4.042	160	71.5
56B14	KC40.4.049	80	71.5
63B14	K050.4.047	90	74
71B14	K050.4.045	105	71.5

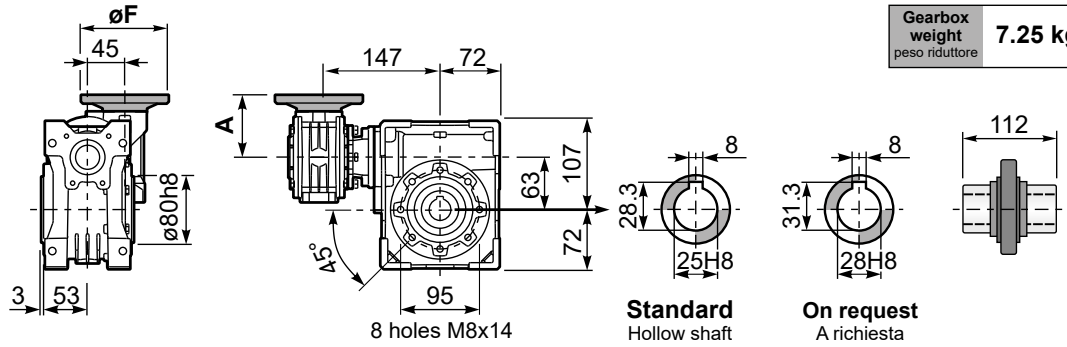

P64MFC... Square flange
Flangia quadrata

P64MF1... Round flange
Flangia rotonda

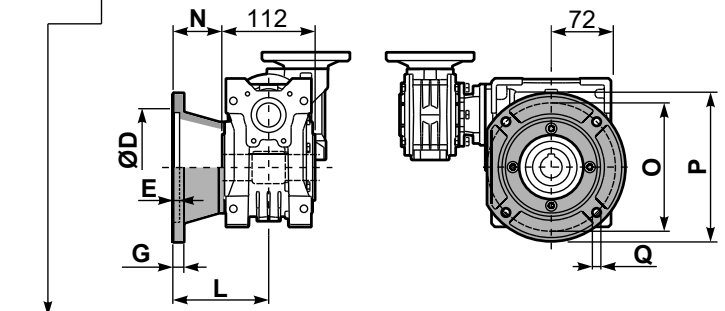
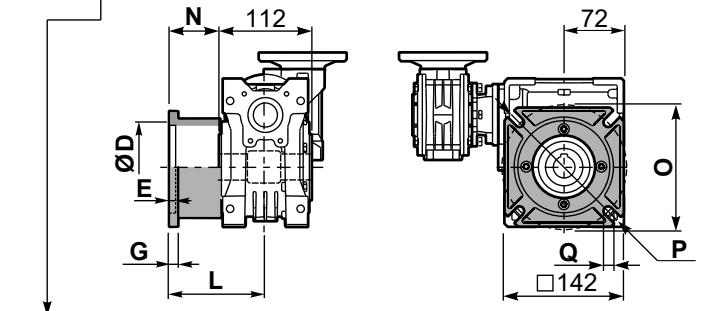

type B	øD	E	G	L	N	O	P	Q	kit code
FC	115 H8	6	10	82	26	150	180	11	KM63.9.010
FL	115 H8	6	10	112	56	150	180	11	KM63.9.011

type S	øD	E	G	L	N	O	P	Q	kit code
F1	130 H8	5	10	98	42	165	200	11	KM63.9.012
F2	130 H8	5	10	107	51	165	200	11	KM63.9.013
F3	110 H8	5	16.5	80.5	24.5	130	160	11	KM63.9.014

P64MFB... Feet
Piedini

P64MBR... Reaction arm
Braccio di reazione

kit cod. KM63.9.027

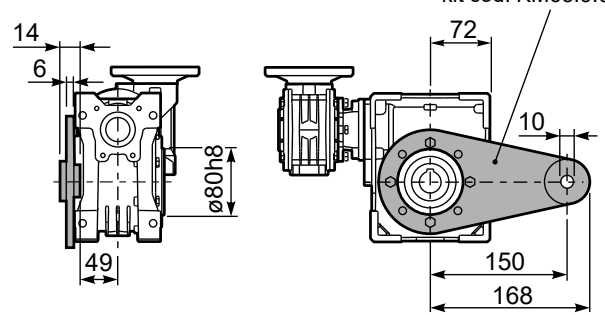
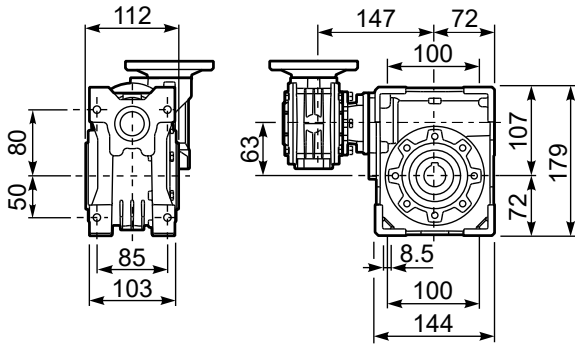

R64MFB... Input shaft
Albero in entrata

P64M.....S... Single Shaft
Albero lento semplice

P64M.....D... Double Shaft
Albero lento bisp.

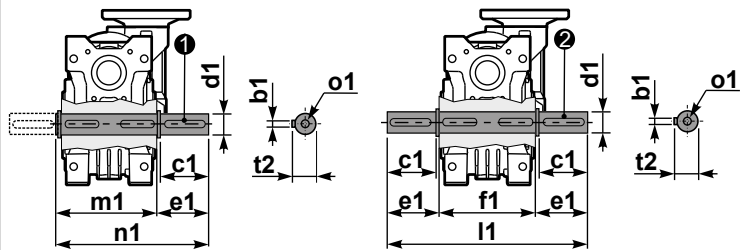
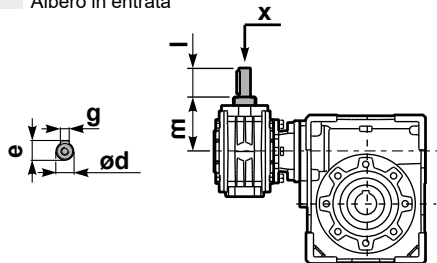

① kit cod. KM63.5.028 type B ② kit cod. KM63.5.029 type B

	ød	e	g	l	m	x	kit code
type B	11 h6	12.5	4	30	68	-	K045.5.006 PAM71
type S	-	-	-	-	-	-	-

	b1	c1	d1	e1	f1	l1	m1	n1	t2	o1
type B	8	50	25h6	53.5	112	219	119.5	173	28	M10x23
type S	-	-	-	-	-	-	-	-	-	-

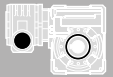

QUICK SELECTION / Selezione veloce

input speed (n_1) = 1400 min⁻¹

Output Speed n_2 [min ⁻¹]	Ratio i	Motor power P_{1M} [kW]	Output torque M_{2M} [Nm]	Service factor f.s.	Nominal power P_{1R} [kW]	Nominal torque M_{2R} [Nm]	Available B5 motor flanges		Available B14 motor flanges			Dynamic efficiency RD	Tooth Module $[mm]$	Ratios code
							-B	-C	-O	-P	-Q			
5	280	0.37	403	1.0	0.39	420	B		B-C	B-C		57	3.10	01
3.5	400	0.25	314	1.3	0.33	420	B		B-C	B-C		46	3.10	02
2.5	560	0.25	420	1.0	0.25	420	B		B-C	B-C		44	3.10	03
1.7	840	0.18	423	1.0	0.18	420	B		B-C	B-C		41	3.10	04
1.3	1120	0.12	339	1.2	0.15	420	B		B-C	B-C		37	3.10	05
0.9	1480	0.09	336	1.2	0.11	420	B		B-C	B-C		37	3.10	06
0.8	1840	0.09	373	1.1	0.10	420	B		B-C	B-C		33	3.10	07
0.6	2400	0.09	413	1.0	0.09	420	B		B-C	B-C		28	3.10	08
0.5	2800	0.06	298	1.4	0.08	420	B		B-C	B-C		26	3.10	09
0.3	4080	0.06	250	1.4	0.09	359	B		B-C	B-C		15	3.10	10

A Motor Flanges Available
Flange Motore Disponibili

B Supplied with Reduction Bushing
Fornito con Bussola di Riduzione

B Available on Request without reduction bushing
Disponibile a Richiesta senza Bussola di Riduzione

C Motor Flange Holes Position
Posizione Fori Flangia Motore

EN Unit **74M** is supplied with synthetic oil, providing "long life" lubrication. For mounting position V5-V6 please contact us. See table 1 for lubrication and recommended quantity. In table 2 please see possible radial loads and axial loads on the gearbox.

I Il riduttore tipo **74M** viene fornito lubrificato a vita con olio sintetico. Per posizioni V5-V6 contattare il ns. servizio tecnico. Vedi tab.1 per oli e quantità consigliati. In tab.2 sono presenti i carichi radiali e assiali applicabili al riduttore.

D Für die Lebensdauerschmierung ist das Getriebe der Größe **74M** mit synthetischem Öl befüllt. Bei Einbaulage V5 oder V6 bitten wir um Rücksprache. In Tabelle 1 ist die Schmiermenge und das empfohlene Schmiermittel angegeben. In Tabelle 2 sind die zulässigen Radial- und Axialbelastungen des Getriebes aufgeführt.

F Le réducteur de type **74M** est fourni lubrifié à vie avec de l'huile synthétique. Concernant les positions V5.V6, contactez notre service d'assistance technique. Voir tableau 1 concernant les huiles et les quantités conseillées. Les charges radiales et axiales applicables au réducteur sont précisées dans le tableau 2.

E El reductor tamaño **74M** se suministra, lubricado de por vida con aceite sintético. Para las posiciones V5 y V6 contactar con nuestro servicio técnico. Ver tabla 1, para cantidades y aceites recomendados. En la tabla 2, se encuentran las cargas radiales y axiales admitidas por el reductor.

0.40 Lt.

■ LUBRICATION 74M Oil
Quantity 0.40/0.09 Lt.

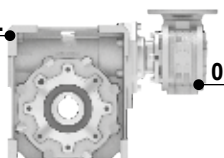

SHELL Omala S4 WE 320

ENI Telium VSF 320

For all details on lubrication and plugs check our website **tab. 1**
Per maggiori dettagli su lubrificazione e tappi olio vedi il nostro sito web

■ RADIAL AND AXIAL LOADS

Output shaft
Albero di uscita

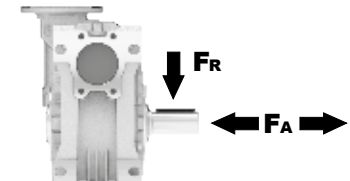

n_2 [min ⁻¹]	FA [N]	FR [N]
25	880	4400
15	1000	5000

Input shaft
albero in entrata

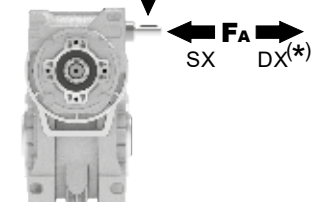

n_1 [min ⁻¹]	FA [N]	FR [N]
1400	42	210

***Strong axial loads in the DX direction are not allowed.**
Non sono consentiti forti carichi assiali con direzione DX

tab. 2

P74MFB... Basic wormbox
Riduttore base

Gearbox weight
peso riduttore **11.4 kg**

M. flanges	Kit code	øF	A
63B5	K050.4.041	138	74
71B5	K050.4.042	160	71.5
56B14	KC40.4.049	80	71.5
63B14	K050.4.047	90	74
71B14	K050.4.045	105	71.5

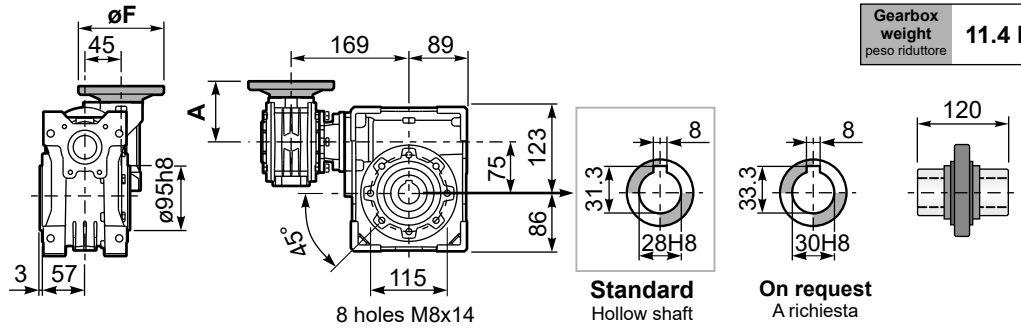

P74MFC... Round flange
Flangia rotonda

P74MFL... Square flange
Flangia quadrata

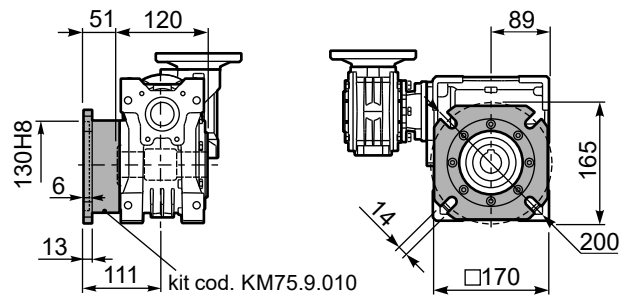
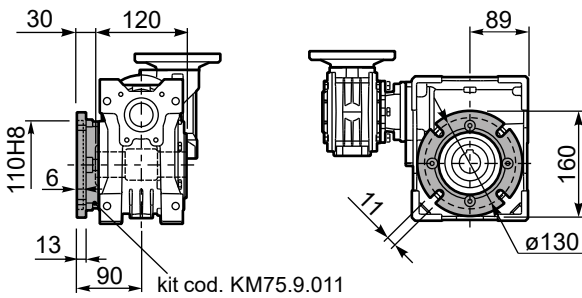

P74MFB... Feet
Piedini

P74MBR... Reaction arm
Braccio di reazione

kit cod. KM75.9.027

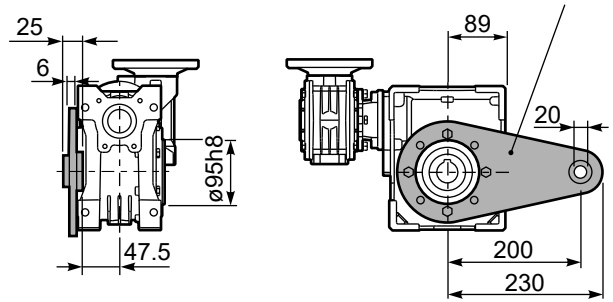
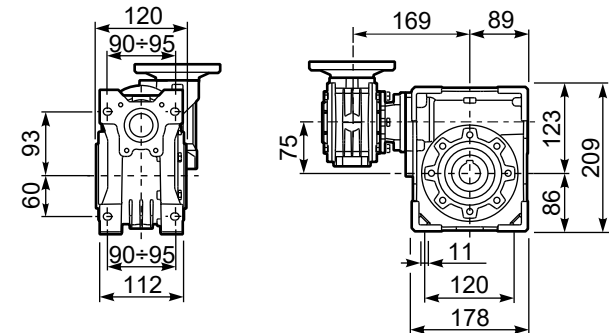

R74MFB... Input shaft
Albero in entrata

P74M...S... Single Shaft
Albero lento semplice

P74M...D... Double Shaft
Albero lento bisp.

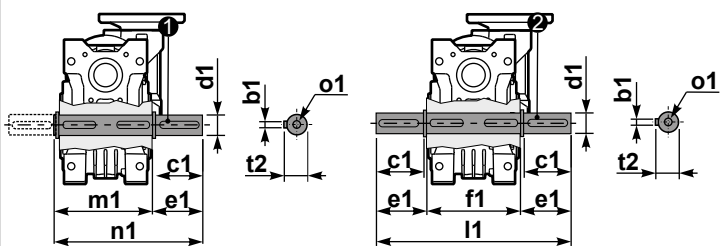
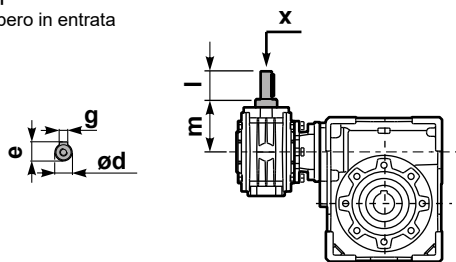

① kit cod. KM75.5.028 Standard ② kit cod. KM75.5.029 Standard

	ød	e	g	l	m	x	kit code
type B	11 h6	12.5	4	30	68	-	K045.5.006 PAM71

	b1	c1	d1	e1	f1	l1	m1	n1	t2	o1
Standard	8	60	28 h6	63.5	120	247	128.5	192	31	M10
On request	-	-	-	-	-	-	-	-	-	-

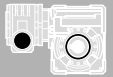

QUICK SELECTION / Selezione veloce

input speed (n_1) = 1400 min⁻¹

Output Speed n_2 [min ⁻¹]	Ratio i	Motor power P_{1M} [kW]	Output torque M_{2M} [Nm]	Service factor f.s.	Nominal power P_{1R} [kW]	Nominal torque M_{2R} [Nm]	Available B5 motor flanges		Available B14 motor flanges			Dynamic efficiency RD	Tooth Module $[mm]$	Ratios code
							-B	-C	-O	-P	-Q			
							63	71	56	63	71			
10	140	0.37	205	2.1	0.76	423	B		B-C	B-C		58	4.5	01
7.1	196	0.37	257	1.6	0.61	423	B		B-C	B-C		52	4.7	02
5.0	280	0.37	332	1.8	0.66	596	B		B-C	B-C		47	4.7	03
3.6	392	0.37	435	1.4	0.51	596	B		B-C	B-C		44	4.7	04
2.4	588	0.37	549	1.1	0.40	596	B		B-C	B-C		37	4.7	05
1.8	784	0.25	455	1.3	0.33	596	B		B-C	B-C		34	4.7	06
1.4	1036	0.25	583	1.0	0.26	596	B		B-C	B-C		33	4.7	07
1.1	1288	0.18	474	1.2	0.22	580	B		B-C	B-C		30	4.7	08
0.7	1960	0.12	449	1.2	0.14	518	B		B-C	B-C		28	4.7	09
0.5	2856	0.12	584	0.9	0.11	518	B		B-C	B-C		25	4.7	10

A) Motor Flanges Available
Flange Motore Disponibili

B) Supplied with Reduction Bushing
Fornito con Bussola di Riduzione

Available on Request without reduction bushing
Disponibile a Richiesta senza Bussola di Riduzione

C) Motor Flange Holes Position
Posizione Fori Flangia Motore

EN Unit **84M** is supplied with synthetic oil, providing "long life" lubrication. For mounting position V5-V6 please contact us. See table 1 for lubrication and recommended quantity. In table 2 please see possible radial loads and axial loads on the gearbox.

I Il riduttore tipo **84M** viene fornito lubrificato a vita con olio sintetico. Per posizioni V5-V6 contattare il ns. servizio tecnico. Vedi tab.1 per oli e quantità consigliati. In tab.2 sono presenti i carichi radiali e assiali applicabili al riduttore.

D Für die Lebensdauerschmierung ist das Getriebe der Größe **84M** mit synthetischem Öl befüllt. Bei Einbaulage V5 oder V6 bitten wir um Rücksprache. In Tabelle 1 ist die Schmiermenge und das empfohlene Schmiermittel angegeben. In Tabelle 2 sind die zulässigen Radial - und Axialbelastungen des Getriebes aufgeführt.

F Le réducteur de type **84M** est fourni lubrifié à vie avec de l'huile synthétique. Concernant les positions V5.V6, contactez notre service d'assistance technique. Voir tableau 1 concernant les huiles et les quantités conseillées. Les charges radiales et axiales applicables au réducteur sont précisées dans le tableau 2.

E El reductor tamaño **84M** se suministra, lubricado de por vida con aceite sintético. Para las posiciones V5 y V6 contactar con nuestro servicio técnico. Ver tabla 1, para cantidades y aceites recomendados. En la tabla 2, se encuentran las cargas radiales y axiales admitidas por el reductor.

LUBRICATION 84M Oil
Quantity 1.20/0.09 Lt.

SHELL Omala S4 WE 320	ENI Telium VSF 320
------------------------------	---------------------------

For all details on lubrication and plugs check our website **tab. 1**
Per maggiori dettagli su lubrificazione e tappi olio vedi il nostro sito web

RADIAL AND AXIAL LOADS

Output shaft

Albero di uscita

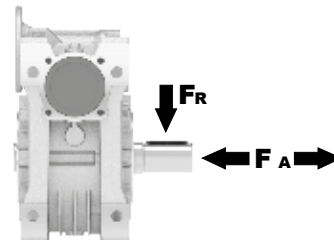

n [min ⁻¹]	FA [N]	FR [N]
25	1000	5000
15	1160	5800

Input shaft

albero in entrata

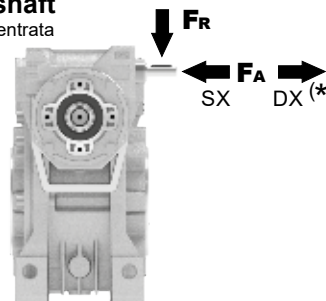

n [min ⁻¹]	FA [N]	FR [N]
1400	42	210

***Strong axial loads in the DX direction are not allowed.**
Non sono consentiti forti carichi assiali con direzione DX

tab. 2

P84MFB... Basic wormbox
Riduttore base

M. flanges	Kit code	øF	A
63B5	K050.4.041	138	74
71B5	K050.4.042	160	71.5
56B14	KC40.4.049	80	71.5
63B14	K050.4.047	90	74
71B14	K050.4.045	105	71.5

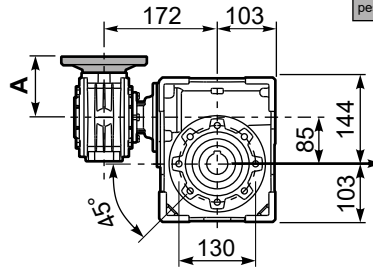
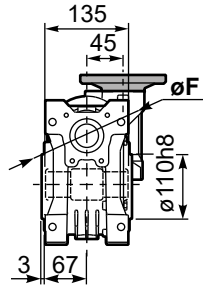

Gearbox weight
peso riduttore **16.2 kg**

ø H8	B	C	*Spacer code
35 Standard	38.3	10	KM85.3.035
38 on request	41.3	10	KM85.3.038

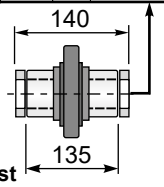
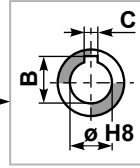

***On Request**
output shaft with spacers

8 holes M10x18

P84MFC... Output flange
Flangia uscita

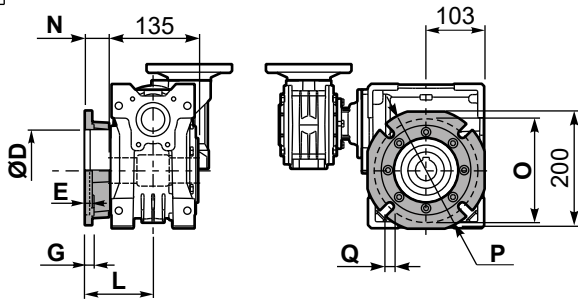

type B	øD	E	G	L	N	O	P	Q	kit code
FC	152 H8	5	16	111	43.5	176	205	13	K085.9.010
FL	180 H8	6	18	122	54.5	215	250	14	KM85.9.011

P84MF1... Output flange
Flangia uscita

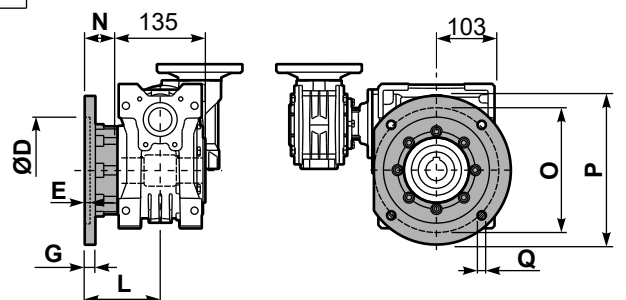

type S	øD	E	G	L	N	O	P	Q	kit code
F1	130 H8	5	13	109.5	42	165	200	13	KS085.9.015
F2	152 H8	5	16	151.5	84	176	205	13	K085.9.010 K085.0.201

P84MFB... Feet
Piedini

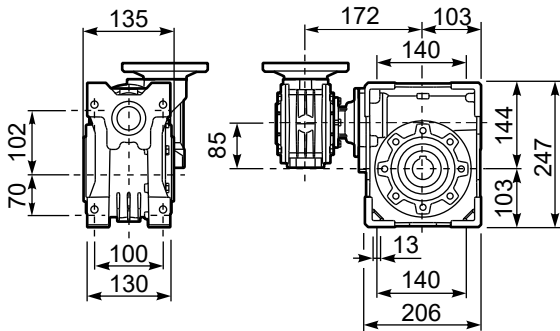

P84MBR... Reaction arm
Braccio di reazione

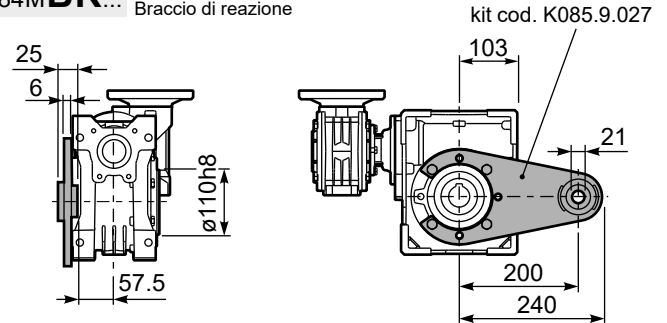

R84MFB... Input shaft
Albero in entrata

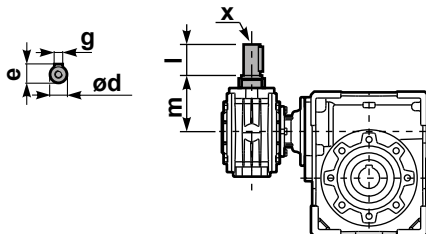

type	ød	e	g	l	m	x	kit code
type B	11 h6	12.5	4	30	68	-	① K045.5.006 PAM71
type S	-	-	-	-	-	-	② -

P84M.....S... Single Shaft
Albero lento semplice

P84M.....D... Double Shaft
Albero lento bisp.

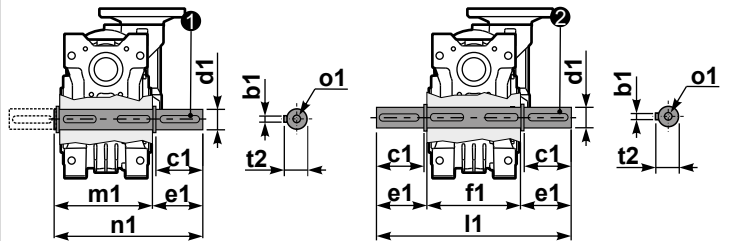

① kit cod. K085.5.028 type B ② kit cod. K085.5.029 type B

type	b1	c1	d1	e1	f1	l1	m1	n1	t2	o1
type B	10	60	35 ^{-0.005} _{-0.020}	73.5	135	282	141	214.5	38	M10x23
type S	-	-	-	-	-	-	-	-	-	-

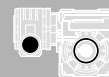

QUICK SELECTION / Selezione veloce

input speed (n_1) = 1400 min⁻¹

Output Speed n_2 [min ⁻¹]	Ratio i	Motor power P_{1M} [kW]	Output torque M_{2M} [Nm]	Service factor f.s.	Nominal power P_{1R} [kW]	Nominal torque M_{2R} [Nm]	Available B5 motor flanges			Available B14 motor flanges				Dynamic efficiency RD	Tooth Module [mm]	 Ratios code
							-B	-C	-D	-O	-P	-Q	-R			
							63	71	80	56	63	71	80			
6.7	210	0.75	591	1.8	1.3	1036	B	B			B-C	B		55	5.6	01
4.7	300	0.75	752	1.6	1.2	1174	B	B			B-C	B		49	5.6	02
3.3	420	0.75	1010	1.2	0.87	1174	B	B			B-C	B		47	5.6	03
2.6	540	0.55	851	1.4	0.76	1174	B	B			B-C	B		42	5.6	04
1.8	780	0.55	1112	1.1	0.58	1174	B	B			B-C	B		38	5.6	05
1.3	1080	0.37	1009	1.2	0.43	1174	B			B-C	B-C			37	5.6	06
1.1	1290	0.37	1140	1.0	0.38	1174	B			B-C	B-C			35	5.6	07
0.8	1800	0.25	921	1.3	0.32	1174	B			B-C	B-C			30	5.6	08
0.7	2040	0.25	1044	1.1	0.28	1174	B			B-C	B-C			30	5.6	09
0.6	2400	0.25	1228	1.0	0.26	1174	B			B-C	B-C			28	5.6	10
0.5	3000	0.18	958	1.0	0.18	978	B			B-C	B-C			26	5.6	11

Motor Flanges Available
Flange Motore Disponibili

B) Supplied with Reduction Bushing
Fornito con Bussola di Riduzione

B) Available on Request without reduction bushing
Disponibile a Richiesta senza Bussola di Riduzione

C) Motor Flange Holes Position
Posizione Fori Flangia Motore

EN Unit **15M** is supplied without lubricant and equipped with a breather, level and drain plugs. User can add mineral oil keeping existing plugs. Should the user wish to fill it with synthetic oil, it is recommended to replace the existing plugs with a type that are closed. Gearbox **050** is supplied lubricated for life. See tab.1 for oils and recommended quantity. In tab.2 there are radial loads and axial loads applicable to the gearbox.

I Il riduttore tipo **15M** è fornito privo di lubrificazione con tappi di sfiato, livello e scarico olio. L'utente può immettere olio minerale mantenendo i tappi esistenti. Se immetterà olio sintetico, dovrà sostituire i tappi esistenti con altri tipo chiuso. Il riduttore **050** è fornito lubrificato a vita con olio sintetico. Tab.1 per oli e quantità consigliati. Tab.2 carichi radiali e assiali applicabili al riduttore.

D Das Getriebe der Baugröße **15M** wird ohne Schmiermittel geliefert. Es ist jedoch mit Einfüllschraube, Überdruckventil und Ablassschraube ausgerüstet. Das benötigte mineralische Öl kann über die Einfüllschraube eingefüllt werden. Sollte synthetisches Öl bevorzugt werden, so ist sind das eingebaute Überdruckventil durch eine geschlossenen Schraube zu ersetzen. Das Getriebe der Baugröße **050** ist lebensdauer geschmiert. In Tabelle 1 ist die Schmiermenge und das empfohlene Schmiermittel angegeben. In Tabelle 2 sind die zulässigen Radial - und Axialbelastungen des Getriebes aufgeführt.

F Le réducteur de type **15M** est fourni sans lubrification et avec un bouchon de remplissage, de niveau et d'évacuation de l'huile. L'utilisateur peut verser de l'huile minérale en conservant les bouchons existants. S'il y versera de l'huile synthétique, il devra substituer les bouchons existants avec d'autres bouchons de type fermé. Le réducteur de type **050** est fourni lubrifié à vie avec de l'huile synthétique. Voir tableau 1 concernant les huiles et les quantités conseillées. Voir tableau 2 concernant les charges radiales et axiales applicables au réducteur.

E El reductor tamaño **15M** se suministra sin lubricante, provisto de tapones de respiración, nivel y descarga de aceite. El usuario puede utilizar aceite mineral, manteniendo los tapones existentes. Si prefiere utilizar aceite sintético deberá sustituir los tapones existentes por tapones ciegos. El reductor **050** se suministra lubricado de por vida con aceite sintético. Ver tabla 1, para cantidades y aceites recomendados. En la tabla 2, se encuentran las cargas radiales y axiales admitidas por el reductor.

B3	B6	B7	B8	V5	V6
1.9/0.14LT	1.35/0.14 LT	1.35/0.14 LT	2.0/0.14 LT	2.0/0.14 LT	2.0/0.14 LT
SHELL Omala S2 GX 460			ENI Blasias 460		

For all details on lubrication and plugs check our website **tab. 1**
Per maggiori dettagli su lubrificazione e tappi olio vedi il nostro sito web

RADIAL AND AXIAL LOADS

Output shaft
Albero di uscita

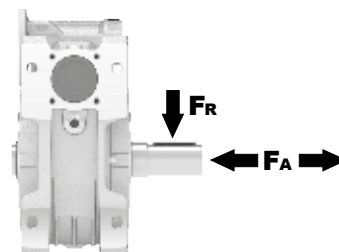

n_2 [min ⁻¹]	FA [N]	FR [N]
25	1200	6000
15	1400	7000

Input shaft
albero in entrata

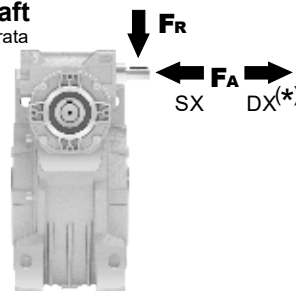

n_1 [min ⁻¹]	FA [N]	FR [N]
1400	76	380

*Strong axial loads in the DX direction are not allowed.
Non sono consentiti forti carichi assiali con direzione DX

tab. 2

P15MFB... Basic wormbox
Riduttore base

Gearbox weight
peso riduttore **38.8 kg**

M. flanges	Kit code	øF	A
63B5	K050.4.041	138	78.5
71B5	K050.4.042	160	76
80B5	K050.4.043	200	76.5
56B14	KC40.4.049	80	76
63B14	K050.4.047	90	78.5
71B14	K050.4.045	105	76
80B14	K050.4.046	120	76.5

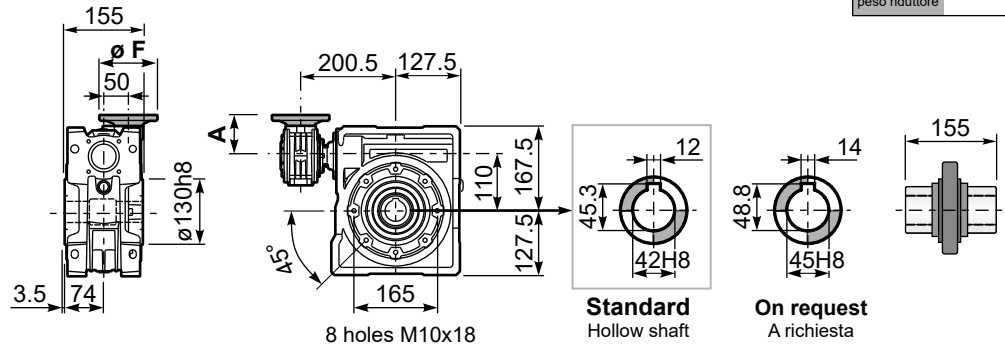

P15MFC... Output flange
Flangia uscita

P15MFL... Output flange
Flangia uscita

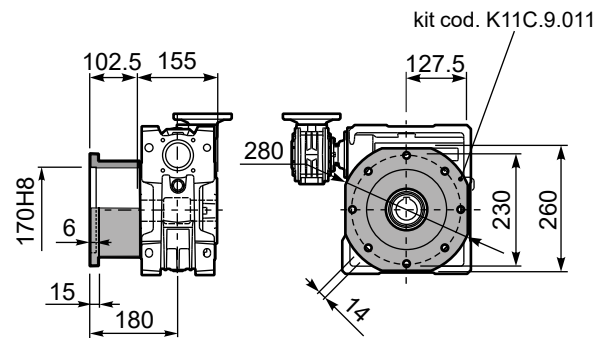
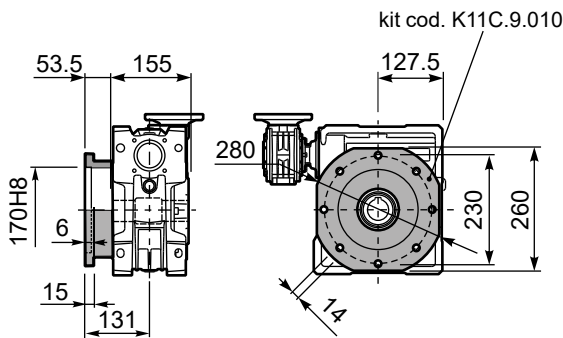

P15MFB... Feet
Piedini

P15MBR... Reaction arm
Braccio di reazione

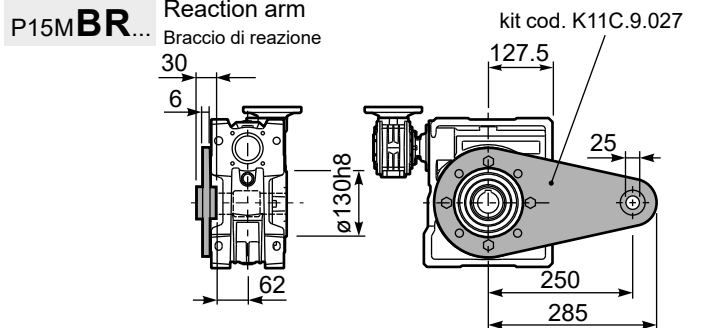
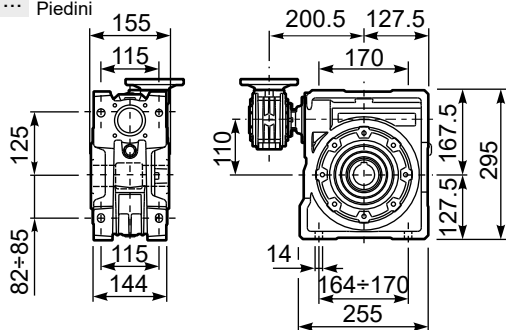

R15MFB... Input shaft
Albero in entrata

P15M.....S... Single Shaft
Albero lento semplice

P15M.....D... Double Shaft
Albero lento bisp.

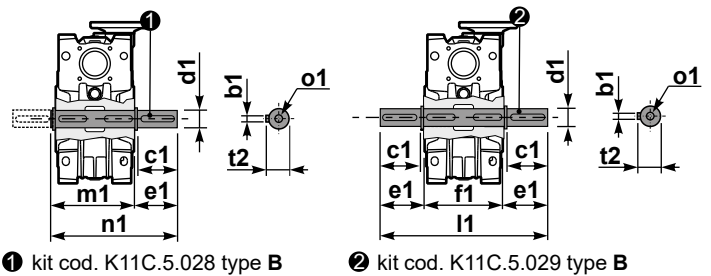
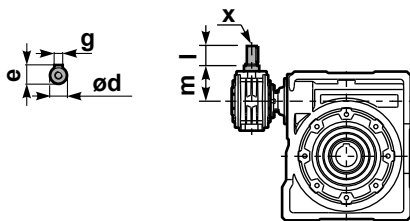

	ød	e	g	l	m	x	kit code
type B	16 h6	18	5	30	79.5	M6x16	1 K050.5.006 PAM71 2 K050.5.007 PAM80
type S	14 h6	16	5	30	79.5	M5x10	1 KS050.5.008 PAM71 2 KS050.5.009 PAM80

	b1	c1	d1	e1	f1	l1	m1	n1	t2	o1
type B	12	80	42h6	84.5	155	324	164.5	249	45	M16x28
type S	-	-	-	-	-	-	-	-	-	-

Q Square worm gearboxes

A modular and compact product

Single-piece aluminum alloy housing

Is vacuum impregnated (MIL-STD 276) for protection and sealing.

No secondary finish required but readily accepts paint. Combines light weight with high tensile strength. Precision machined for alignment of bearings and gearing.

Single piece alloy steel input shaft and worm shaft.

High helix angle worm is case-hardened (Rc 58-60), ground, teeth are profiled and radiused, for noise reduction and enhanced efficiency.

Oversized bearings

Support positively-retained, high speed shaft for higher shock load capacity - ideal for frequent starting and reversing application. Premium, Nitrile® high temperature seals each end.

Flange

Fully modular to IEC and compact integrated motor. NEMA C flange.

Premium, high temperature

Nitrile® output seals

Bronze alloy worm gears.

CuSn12Ni (C91700) Nickel bronze worm gears are centrifugally cast onto an iron hub for maximum strength and superior life. Removable hollow shaft with key for safe torque transmissions.

Oversize bearing

For radial load capability and maximum hollow output shaft diameter.

Standard hollow output shaft mounting

Reduces total drive envelope size, weight and cost. Single and double solid output shaft is available.

Impregnated and machined bearing caps

With exterior machined surfaces enable a variety of mounting accessories. Extra-deep thread engagement provided for greater support strength. Zinc plated hardware.

Painting

Cast iron gearboxes are painted RAL 7046

Vent Free Design.

No breather or vents to leak! Factory lubricated for life with synthetic, semi-fluid gear lubricant with an operating range of -15°C to 130°C.

oil free



vent free



Specific type datasheet on page...

On page / A pagina / Auf Seite / À la page / En la página

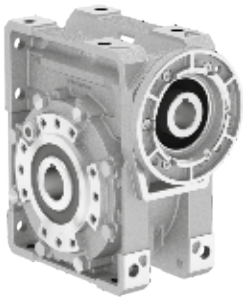

Types / Tipi /
Tipen / Types /
Tipos →

3-5	3-7	3-9	3-11
Q63 147Nm	Q75 270Nm	Q85 347Nm	Q11 651Nm

On page / A pagina / Auf Seite / À la page / En la página

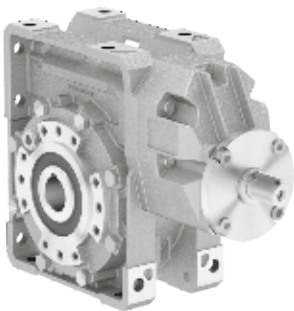

Types / Tipi /
Tipen / Types /
Tipos →

3-13	3-15	3-17	3-19
P6Q 187Nm	P7Q 310Nm	P8Q 440Nm	P1Q 803Nm

On page / A pagina / Auf Seite / À la page / En la página

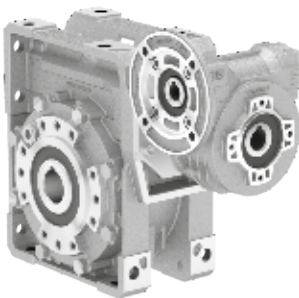

Types / Tipi /
Tipen / Types /
Tipos →

3-21	3-23	3-25	3-27	3-29
63Q 230Nm	64Q 265Nm	74Q 359Nm	84Q 518Nm	15Q 978Nm

On page / A pagina / Auf Seite / À la page / En la página

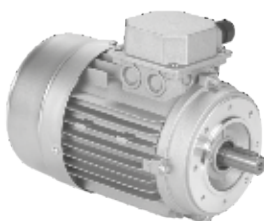

Types / Tipi
Tipen / Types
Tipos →

M-1										
56A 56B	63A 63B	71A 71B	80A 80B	90S 90L	100LA 100LB	112M	132S 132M	160M 160L	180M 180L	

Type - Tipo - Typ
Type - Tipo

Size - Grandezza
Größe - Taille
Tamaño

Mounting - Montaggio - Montage Fixation
Fixation - Tipo de montaje

P

Q63

FC

Worm gearboxes
Riduttori a vite senza fine
Schneckengetriebe
Reducteurs a vis sans fin
Reductores de corona sin fin

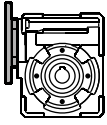

P

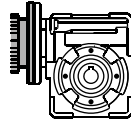

M

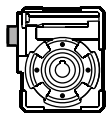

B

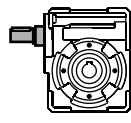

R

Q63
Q75
Q85
Q11

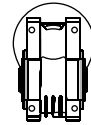

FB

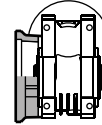

FC

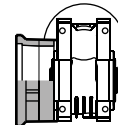

FL

F1
F2
F3
F4

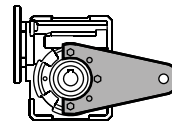

BR

Worm gearboxes with primary reduction
Riduttori a vite senza fine con precoppia
Schneckengetriebe mit Stirradstufe am Eintrieb
Reducteurs a vis sans fin avec pré-réduction
Reductores corona sin fin con prereductora de engrajes

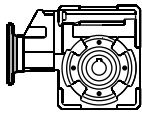

P

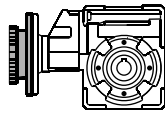

M

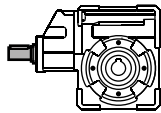

R

P6Q
P7Q
P8Q
P1Q

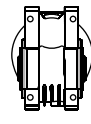

FB

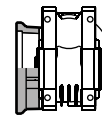

FC

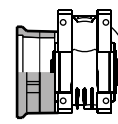

FL

F1
F2
F3
F4

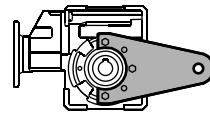

BR

Combined worm gearboxes
Riduttori a vite senza fine combinati
Schneckengetriebekombinationen
Reducteurs a double train de vis sans fin
Reductores combinados corona sin fin

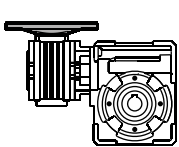

P

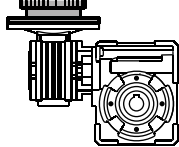

M

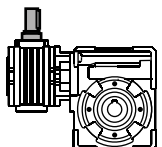

R

63Q
64Q
74Q
84Q
15Q

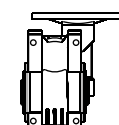

FB

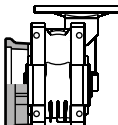

FC

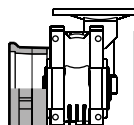

FL

F1
F2
F3
F4

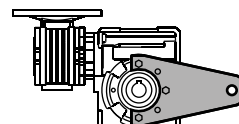



BR

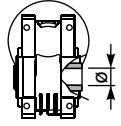
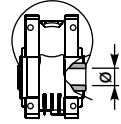
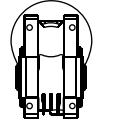
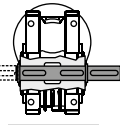
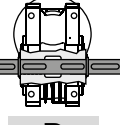
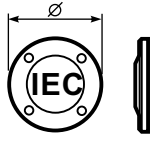
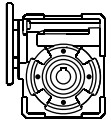
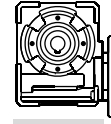
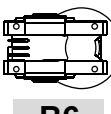
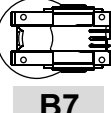
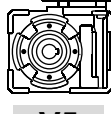
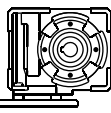
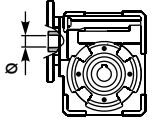
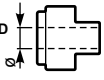
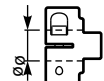
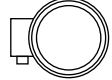
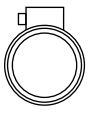
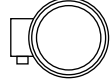
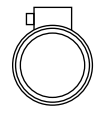

On request we can deliver our products according to the ATEX
A richiesta possiamo fornire i nostri prodotti secondo le normative ATEX
Auf Anfrage können wir unsere Produkte den Richtlinien ATEX entsprechend liefern
Sur demande nos produits peuvent se conformer à la réglementation ATEX
A pedido, se pueden enviar nuestros productos de acuerdo con las normas ATEX.

CODIFICA / HOW TO ORDER / TYPENBEZEICHNUNGEN / CODIFICATION / CODIFICACIÓN

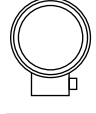
Ratio Rapporto Untersetzung Reduction Relación	Hub Mozzo corona Hohlwelle Arbre creux Nucleo corona	Output shaft Albero lento Abtriebswelle Arbre de sortie Eje salida	Motor size Grandezza motore Motor Grösse Grandeur moteur Tamaño motor	Mounting position Posizione montaggio Einbaulage Position de montage Posición de montaje	Input bore Foro entrata Eingangshohlwelle Trou d'entree Eje hueco de entrada	Mountin position Esecuzione montaggio Einbaulage Exécution de montage Posición de montaje	Terminal box position Posizione morsettera Klemmkastenlage Position boîte a bornes Posición caja de bornes
10	C	∅	-Q	B3	ST	---	
See technical data table Vedi tabella dati tecnici. Technisches Datenblatt beachten Voir tableau données techniques Ver tabla datos técnicos	 STANDARD C Q63 ⇨ ∅25 Q75 ⇨ ∅30 Q85 ⇨ ∅35 Q11 ⇨ ∅42 I Stainless steel hub Mozzo in acciaio Inox Edelstahlhohlwelle Moyeu en acier Inox Nucleo corona de acero Inox  INCH U Q63 ⇨ ∅1.125" Q85 ⇨ ∅1.500" Z Stainless steel hub Mozzo in acciaio Inox Edelstahlhohlwelle Moyeu en acier Inox Nucleo corona de acero Inox	 ∅  S  D	 -M without flange Senza flangia B5 -A=56 (∅120) -B=63 (∅140) -C=71 (∅160) -D=80 (∅200) -E=90 (∅200) -F=100 (∅250) -G=132 (∅300) -H=160 (∅350) B14 -O=56 (∅80) -P=63 (∅90) -Q=71 (∅105) -R=80 (∅120) -T=90 (∅140) -U=100 (∅160) -V=132 (∅200) Brushless BB=50/70-M5 BC=60/75-M5 BD=70/90-M6 BE=80/100-M6 BF=95/115-M8 BG=110/145-M8 BH=130/165-M8 -0=Type R -S=Type R S series	 B3  B8  B6  B7  V5  V6	 ST Standard bore * Kit R standard Foro standard * Kit R standard Input bore without Reduction Bushing -O = 9mm -P = 11mm -Q = 14mm -R = 19mm -T = 24mm -U = 28mm -V = 38mm COUPLING STANDARD (IEC)  -A = 9mm -B = 11mm -C = 14mm -D = 19mm -E = 24mm -F = 28mm BRUSHLESS *  -3 = 14mm -4 = 19mm -5 = 22mm -6 = 24mm Ready for input coupling Predisposto per giunto  -0 Type B Tipo B  -0 Type R Tipo R	Only for combined units See technical data table Solo per i riduttori combinati Vedi tabella dati tecnici. Ausführungen für Getriebekombinationen it Uniquement pour combinés. Voir tableau données techniques Sólo para combinados ver tabla datos técnicos	With Type M specify terminal box position Con tipo M specificare posizione morsettera  A  B STANDARD  C  D

* With reduction bushing where applicable
 Con bussola di riduzione dove prevista

POTENZA RICHIESTA / REQUIRED POWER / ERFORDERLICHE LEISTUNG / PUISSANCE NECESSAIRE / POTENCIA NECESARIA

Lifting / sollevamento / hubantriebe / levage / elevación	$P [KW] = \frac{M [Kg] \cdot g [9.81] \cdot v [m / s]}{1000}$
Rotation / rotazione / drehung / rotation / rotação	$P [KW] = \frac{M [Nm] \cdot n [rpm]}{9550}$
Linear movement / traslazione / linearbewegung / translation / translación	$P [KW] = \frac{F [N] \cdot v [m / s]}{1000}$

3

TORQUE / COPPIA / DREHMOMENT / COUPLE / PAR

	$M [Nm] = \frac{9550 \cdot P[KW]}{n [rpm]}$
	$M [lb in] = \frac{63030 \cdot P[HP]}{n [rpm]}$

RADIAL LOADS / CARICHI RADIALI / RADIALE - UND AXIALLASTEN / CHARGES RADIALES / CARGA RADIAL Y AXIAL

- Radial load generated by external transmissions keyed onto input and/or output shafts.
- Forza radiale generata da organi di trasmissione calettati sugli alberi di ingresso e/o uscita.
- Belastungen der Antriebs- bzw. Abtriebswellen durch von aussen eingebrachte Radiallasten.
- Charge radiale générée par la transmissions calés sur les entrées et / ou des arbres de sortie
- Cargas radiales, generada por transmisiones externas, aplicadas sobre los ejes de entrada y/o salida

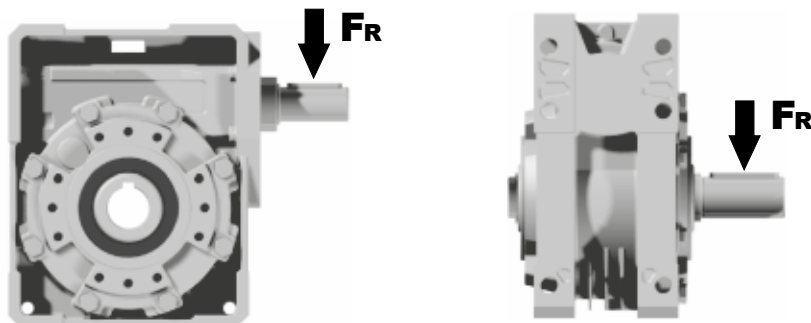

	$F_R [N] = \frac{M [Nm] \cdot 2000}{d [mm]} \cdot f_k$	$F_R [N] = \frac{M [lb in] \cdot 8.9}{d [in]} \cdot f_k$
M	Momento torcente / Output torque / Abtriebsdrehmoment / Couple / Par torsion	
d	Diametro primitivo / Diam. of driving element / Durchmesser der Abtriebseinheit / Diamètre primitif / Diámetro primitivo	
f_k	Coefficiente di trasformazione / Factor / Faktor / Coefficient de transmission / Coeficiente de transmisión 1.15 Ingranaggi / Gearwheels / Zahnrad / Engrenage / Engranaje 1.25 Catena / Chain sprockets / Antriebskette / Chaîne / Cadena 1.75 Cinghia Trapezoidale / Narrow v-belt pulley / Keilriemen / Courroie trap. / Correa trapezoidal 2.50 Cinghia piatta / Flat-belt pulley / Flachzahnriem. / Courroie crantée / Correa plana	

- If your application requires higher radial loads, contact our technical office. Higher load may be possible.
- Nel caso la vostra applicazione richieda carichi radiali superiori consultare il nostro ufficio tecnico, valori maggiori possono essere accettati.
- Wenn Ihre Anwendung höhere Radialbelastungen erfordert, so wenden Sie sich bitte an unser technischen Büro.
- Si votre application demande des charges radiales supérieures, s'adresser à notre bureau technique.
- En el caso en que una aplicación exija una carga radial superior a la especificada en el catálogo, consultar a nuestra oficinas técnica.

How to select a gearbox / Come selezionare un riduttore / Wie wählt man ein Getriebe
Comment sélectionner un réducteur / Cómo seleccionar un reductor

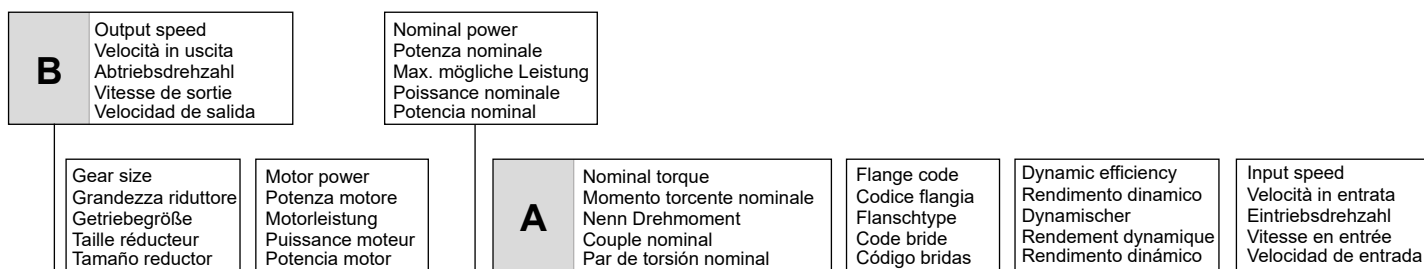

Q63 Q Square - Gear
147Nm

Rating - Aluminum WORM GEARBOXES



QUICK SELECTION / Selezione veloce

Output Speed n_2 [min ⁻¹]	Ratio i	Motor power P_{1M} [kW]	Output torque M_{2M} [Nm]	Service factor f.s.	Nominal power P_{1R} [kW]	Nominal torque M_{2R} [Nm]	Available B5 motor flanges				Available B14 motor flanges			Dynamic efficiency RD	Tooth Module [mm]	Ratios code	
							-B	-C	-D	-E	-Q	-R	-T				
							63	71	80	90	71	80	90				
200	7	1.8	71	1.8	3.2	125		B	B			B-C	B-C		83	3.1	01
140	10	1.8	99	1.4	2.4	134		B	B			B-C	B-C		81	3.1	02
93	15	1.5	121	1.1	1.7	138		B	B			B-C	B-C		79	3.1	03

C Ratio
Rapporto
Untersetzung
Rapport de réduction
Relación

Transmitted torque
Momento torcente trasmesso
Mögliche Drehmomente
Couple de sortie
Par transmitido

Service factor
Fattore di servizio
Betriebsfaktor
Facteur de service
Factor de servicio

Nominal module
Modulo nominale
Nenn modul
Module nominale
Módulo nominal

Notes
Note
Anmerkungen
Note
Notas

Type of load and starts per hour Tipo di carico e avviamenti per ora		Oper. hours per day Ore di funz. giorn.		
		<2 h	2 - 8 h	8 - 16 h
Continuous or intermittent appl. with start / hour Applicazione cont. o interm. con n.ro operazioni/ora	Uniform / Uniforme	0.9	1	1.25
	Moderate / Moderato	1	1.25	1.5
	Heavy / Forte	1.25	1.5	1.75
Intermittent application with start / hour Applicazione intermittente con n.ro operazioni/ora	Uniform / Uniforme	1.25	1.5	1.75
	Moderate / Moderato	1.5	1.75	2
	Heavy / Forte	1.75	2	2.25

D	Motor flange available Flange disponibili Erhältliche Motorflansche Brides disponibles Bridas disponibles
B)	Mounting with reduction ring Montaggio con boccolla di riduzione Reduzierhülsen Montage avec douille de réduction Montaje con casquillo de reducción
C)	Motor flangeholes position/terminal box position Posizione fori flangia/basetta motore Bohrungsposition am Motorflansch/-sockel Position trous bride/barrette à bornes moteur Posición agujeros brida / base motor
B)	Available without reduction bushes Disponibile anche senza boccolla Auch ohne Reduzierbuchse verfügbar Disponible aussi sans douille de réduction Disponible también sin casquillo

A	Select required torque (according to service factor)	Seleziona la coppia desiderata (comprensiva del fattore di servizio)	Max. Drehmoment in Bezug zum Betriebsfaktor	Sélectionner le couple souhaité (comprenant le facteur de service)	Seleccionar el par deseado (incluyendo el factor de servicio)
B	Select output speed	Seleziona la velocità in uscita	Ausgewählte Abtriebsdrehzahl	Sélectionner la vitesse de sortie	Seleccionar la velocidad de salida
C	On the same line of selected geared motor, you can find the gear ratio	Sulla riga corrispondente alla motorizzazione prescelta si può rilevare il rapporto di riduzione	Auf der gleichen Linie wie die ausgewählte Motorleistung steht auch die Getriebeuntersetzung	Sur la ligne correspondante à la motorisation pré-choisie on peut relever le rapport de réduction	En la línea correspondiente al motor preseleccionado es posible encontrar la relación de reducción
D	Select motor flange available (if requested)	Scegli la flangia disponibile (se richiesta)	Erhältliche Motorflansche (auf Anfrage)	Choisir la bride disponible (si elle est demandée)	Seleccionar la brida disponible (sobre pedido)



QUICK SELECTION / Selezione veloce

input speed (n_1) = 1400 min⁻¹

Output Speed n_2 [min ⁻¹]	Ratio i	Motor power P_{1M} [kW]	Output torque M_{2M} [Nm]	Service factor f.s.	Nominal power P_{1R} [kW]	Nominal torque M_{2R} [Nm]	Available B5 motor flanges				Available B14 motor flanges			Dynamic efficiency RD	Tooth Module [mm]	Ratios code 	
							-B	-C	-D	-E	-Q	-R	-T				
							63	71	80	90	71	80	90				
200	7	1.8	71	1.8	3.2	125		B	B			B-C	B-C		83	3.1	01
140	10	1.8	99	1.4	2.4	134		B	B			B-C	B-C		81	3.1	02
93	15	1.5	121	1.1	1.7	138		B	B			B-C	B-C		79	3.1	03
74	19	1.1	111	1.2	1.4	138		B	B			B-C	B-C		78	2.6	04
58	24	1.1	135	1.0	1.2	142		B	B			B-C	B-C		75	2.0	05
47	30	1.1	167	0.9	0.96	146		B	B			B-C	B-C		74	3.2	06
39	36	0.75	125	1.2	0.88	147		B	B			B-C	B-C		68	2.7	07
35	40	0.75	135	1.0	0.78	140		B	B			B-C	B-C		66	2.5	13
31	45	0.55	111	1.2	0.67	135	B	B				B-C	C		66	2.1	08
23	60	0.55	140	0.9	0.51	130	B	B				B-C	C		62	1.6	12
21	67	0.55	151	0.8	0.45	124	B	B				B-C	C		60	1.5	09
17.5	80	0.37	115	1.0	0.38	119	B	B				B-C	C		57	1.3	10
14.9	94	0.37	123	1.0	0.36	119	B	B				B-C	C		52	1.1	11

A Motor Flanges Available
Flange Motore Disponibili

B Supplied with Reduction Bushing
Fornito con Bussola di Riduzione

B Available on Request without reduction bushing
Disponibile a Richiesta senza Bussola di Riduzione

C Motor Flange Holes Position
Posizione Fori Flangia Motore

EN Unit **Q63** is supplied with synthetic oil, providing "long life" lubrication. For mounting position V5-V6 please contact us. See table 1 for lubrication and recommended quantity. In table 2 please see possible radial loads and axial loads on the gearbox.

I Il riduttore tipo **Q63** viene fornito lubrificato a vita con olio sintetico. Per posizioni V5-V6 contattare il ns. servizio tecnico. Vedi tab.1 per oli e quantità consigliati. In tab.2 sono presenti i carichi radiali e assiali applicabili al riduttore.

D Für die Lebensdauerschmierung ist das Getriebe der Größe **Q63** mit synthetischem Öl befüllt. Bei Einbaulage V5 oder V6 bitten wir um Rücksprache. In Tabelle 1 ist die Schmiermenge und das empfohlene Schmiermittel angegeben. In Tabelle 2 sind die zulässigen Radial - und Axialbelastungen des Getriebes aufgeführt.

F Le réducteur de type **Q63** est fourni lubrifié à vie avec de l'huile synthétique. Concernant les positions V5.V6, contactez notre service d'assistance technique. Voir tableau 1 concernant les huiles et les quantités conseillées. Les charges radiales et axiales applicables au réducteur sont précisées dans le tableau 2.

E El reductor tamaño **Q63** se suministra, lubricado de por vida con aceite sintético. Para las posiciones V5 y V6 contactar con nuestro servicio técnico. Ver tabla 1, para cantidades y aceites recomendados. En la tabla 2, se encuentran las cargas radiales y axiales admitidas por el reductor.

LUBRICATION Q63 Oil Quantity 0.30 Lt.

SHELL Omala S4 WE 320

ENI Telium VSF 320

For all details on lubrication and plugs check our website **tab. 1**
Per maggiori dettagli su lubrificazione e tappi olio vedi il nostro sito web

RADIAL AND AXIAL LOADS

Output shaft

Albero di uscita

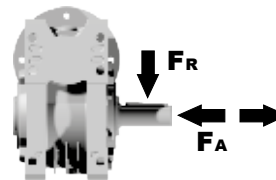

n_2 [min ⁻¹]	F_A [N]	F_R [N]
200	360	1800
150	400	2000
100	460	2300
75	500	2500
50	600	3000
25	700	3800
15	800	4000

Input shaft

albero in entrata

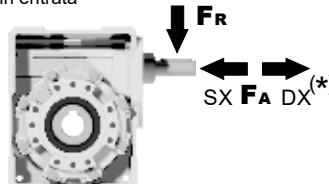

n_1 [min ⁻¹]	F_A [N]	F_R [N]
1400	90	450

***Strong axial loads in the DX direction are not allowed.**
Non sono consentiti forti carichi assiali con direzione DX

tab. 2

3D dimensions on the Web

PQ63**FB**... Basic wormbox
Riduttore base

Gearbox weight
peso riduttore **6.00 kg**

M. flanges	Kit code	øF	A
63B5	K063.4.041	140	99.5
71B5	K063.4.042	160	97.5
80/90B5	K063.4.043	200	99.5
71B14	K063.4.047	105	97.5
80B14	K063.4.046	120	99.5
90B14	K063.4.041	140	99.5

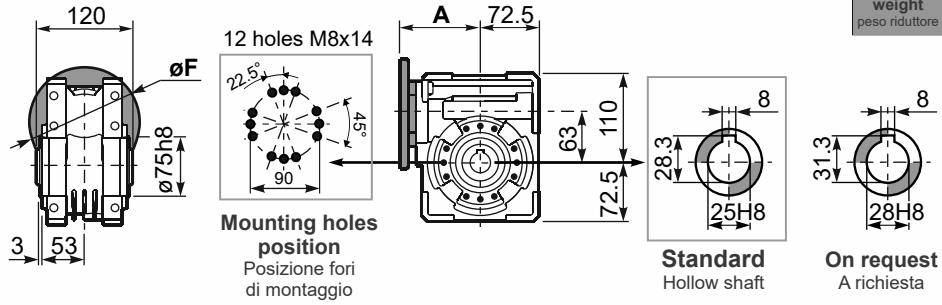

PQ63**FC**... Square flange
Flangia quadrata

PQ63**F1**... Round flange
Flangia rotonda

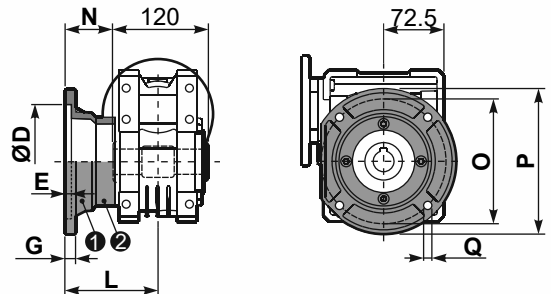
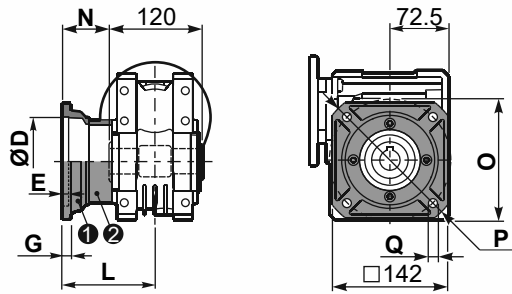

type B	øD	E	G	L	N	O	P	Q	kit code
FC	115 ^{+0.20} / _{+0.15}	6	12	86	26	150	180	11	1 KQ63.9.010 2 -
FL	115 ^{+0.20} / _{+0.15}	6	12	116	56	150	180	11	1 KQ63.9.010 2 K063.0.200

type S	øD	E	G	L	N	O	P	Q	kit code
F1	130 ^{+0.20} / _{+0.15}	7	13	110	50	165	200	13	1 KS070.9.013 2 -
F2	115 ^{+0.20} / _{+0.15}	7	13	124	64	150	175	11	1 KS063.9.013 2 -
F3	110 ^{+0.035} / ₀	5	11	90	30	130	160	10	1 KS063.9.011 2 -

PQ63**FB**... Feet
Piedini

PQ63**BR**... Reaction arm
Braccio di reazione

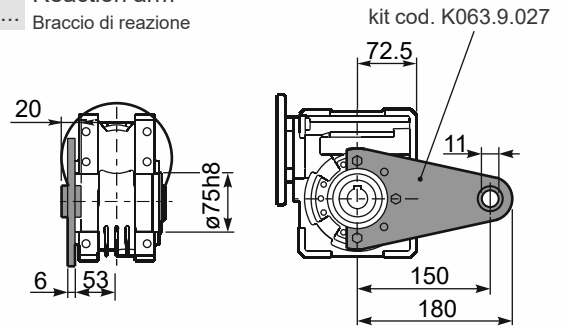
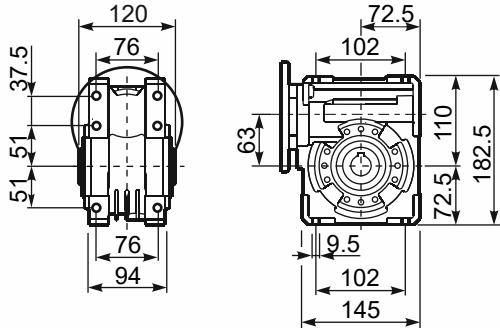

RQ63**FB**... Input shaft
Albero in entrata

PQ63.....**S**... Single Shaft
Albero lento semplice

PQ63.....**D**... Double Shaft
Albero lento bisp.

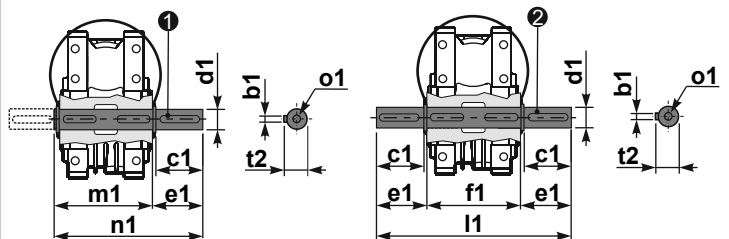
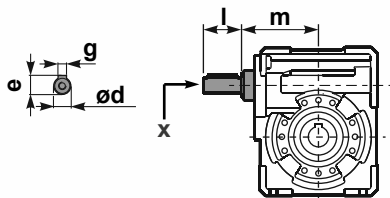

1 kit cod. K063.5.028 type B

2 kit cod. K063.5.029 type B

	ød	e	g	l	m	x	kit code
type B	18 h6	20.5	6	45	93	M6x16	1 K063.5.006 PAM80 2 K063.5.007 PAM90
type S	19 h6	21.5	6	40	93	M8x20	1 KS063.5.008 PAM80 2 KS063.5.009 PAM90

	b1	c1	d1	e1	f1	l1	m1	n1	t2	o1
type B	8	60	25 ^{-0.005} / _{-0.020}	63.2	120	246.4	126.8	190	28	M8x20
type S	-	-	-	-	-	-	-	-	-	-



QUICK SELECTION / Selezione veloce

input speed (n_1) = 1400 min⁻¹

Output Speed n_2 [min ⁻¹]	Ratio i	Motor power P_{1M} [kW]	Output torque M_{2M} [Nm]	Service factor f.s.	Nominal power P_{1R} [kW]	Nominal torque M_{2R} [Nm]	Available B5 motor flanges				Available B14 motor flanges			Dynamic efficiency RD	Tooth Module [mm]	Ratios code	
							-C	-D	-E	-F	-R	-T	-U				
							71	80	90	100 112	80	90	100 112				
200	7	4	172	1.1	4.4	190		B	B			B	B		90	3.75	01
140	10	4	240	1.0	3.8	230		B	B			B	B		88	3.75	02
93	15	3	261	1.0	2.9	250		B	B			B	B		85	3.75	03
70	20	2.2	249	1.0	2.2	250		B	B			B	B		83	3.00	04
56	25	1.5	205	1.2	1.8	250	B	B				B			80	2.41	05
45	31	1.5	244	1.1	1.7	270	B	B				B			77	3.75	06
35	40	1.5	295	0.9	1.3	255	B	B				B			72	3.10	07
28	50	0.75	174	1.3	0.95	220	B								68	2.41	08
23	60	0.75	200	1.0	0.75	200	B								65	2.10	09
17.5	80	0.55	177	1.0	0.56	180	B								59	1.53	10
14.0	100	0.55*	206	0.7	0.40	150	B								55	1.23	11

A Motor Flanges Available
Flange Motore Disponibili

B Supplied with Reduction Bushing
Fornito con Bussola di Riduzione

B Available on Request without reduction bushing
Disponibile a Richiesta senza Bussola di Riduzione

C Motor Flange Holes Position
Posizione Fori Flangia Motore

EN Unit Q75 is supplied with synthetic oil, providing "long life" lubrication. For mounting position V5-V6 please contact us. See table 1 for lubrication and recommended quantity. In table 2 please see possible radial loads and axial loads on the gearbox.

I Il riduttore tipo Q75 viene fornito lubrificato a vita con olio sintetico. Per posizioni V5-V6 contattare il ns. servizio tecnico. Vedi tab.1 per oli e quantità consigliati. In tab.2 sono presenti i carichi radiali e assiali applicabili al riduttore.

D Für die Lebensdauerschmierung ist das Getriebe der Größe Q75 mit synthetischem Öl befüllt. Bei Einbaulage V5 oder V6 bitten wir um Rücksprache. In Tabelle 1 ist die Schmiermenge und das empfohlene Schmiermittel angegeben. In Tabelle 2 sind die zulässigen Radial- und Axialbelastungen des Getriebes aufgeführt.

F Le réducteur de type Q75 est fourni lubrifié à vie avec de l'huile synthétique. Concernant les positions V5.V6, contactez notre service d'assistance technique. Voir tableau 1 concernant les huiles et les quantités conseillées. Les charges radiales et axiales applicables au réducteur sont précisées dans le tableau 2.

E El reductor tamaño Q75 se suministra, lubricado de por vida con aceite sintético. Para las posiciones V5 y V6 contactar con nuestro servicio técnico. Ver tabla 1, para cantidades y aceites recomendados. En la tabla 2, se encuentran las cargas radiales y axiales admitidas por el reductor.

LUBRICATION Q75 Oil Quantity 0.40 Lt.

SHELL Omala S4 WE 320

ENI Telium VSF 320

For all details on lubrication and plugs check our website **tab. 1**
Per maggiori dettagli su lubrificazione e tappi olio vedi il nostro sito web

RADIAL AND AXIAL LOADS

Output shaft
Albero di uscita

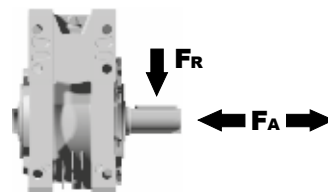

n_2 [min ⁻¹]	FA [N]	FR [N]
200	460	2300
150	520	2600
100	560	2800
75	620	3100
50	720	3600
25	880	4400
15	1000	5000

Input shaft
albero in entrata

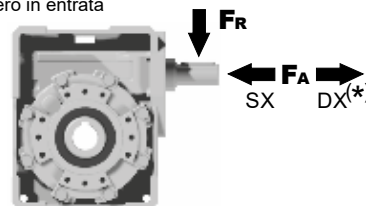

n_1 [min ⁻¹]	FA [N]	FR [N]
1400	125	630

***Strong axial loads in the DX direction are not allowed.**
Non sono consentiti forti carichi assiali con direzione DX

tab. 2

PQ75**FB**... Basic wormbox
Riduttore base

Gearbox weight
peso riduttore **8.70 kg**

M. flanges	Kit code	øF	A
71B5	K023.4.041	160	114
80/90B5	K023.4.042	200	116
100/112B5	K023.4.043	250	125
80B14	K085.4.046	120	116
90B14	K085.4.045	140	116
100/112B14	K085.4.047	160	125

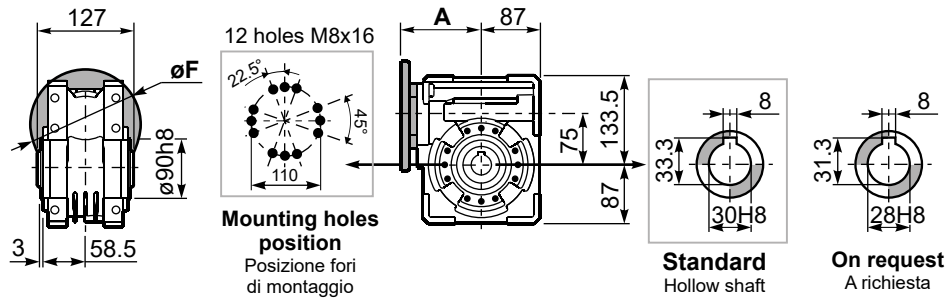

PQ75**FC**... Square flange
Flangia quadrata

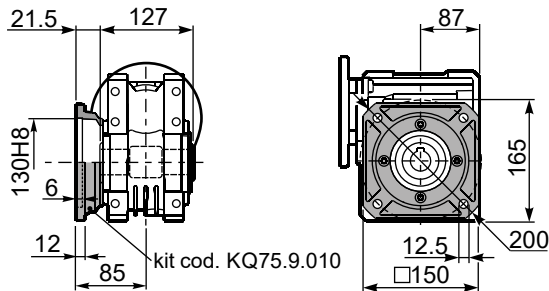

PQ75**FL**... Square flange
Flangia quadrata

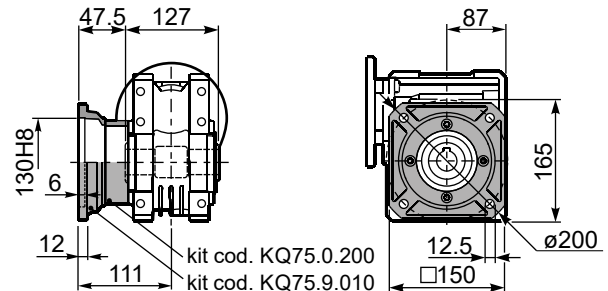

PQ75**FB**... Feet
Piedini

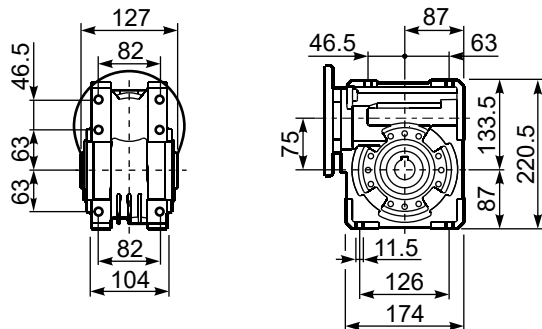

PQ75**BR**... Reaction arm
Braccio di reazione

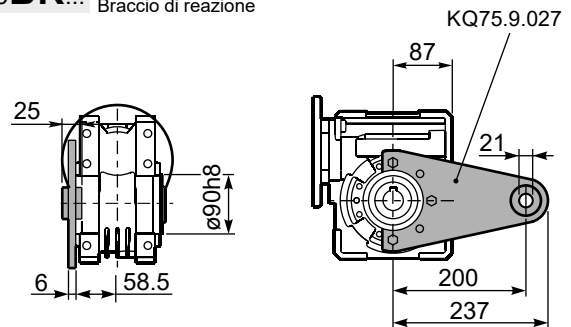

RQ75**FB**... Input shaft
Albero in entrata

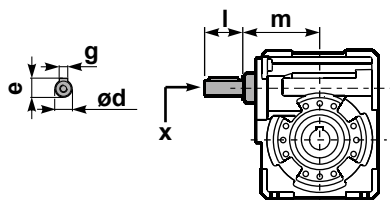

PQ75....**S**... Single Shaft
Albero lento semplice

PQ75....**D**... Double Shaft
Albero lento bisp.

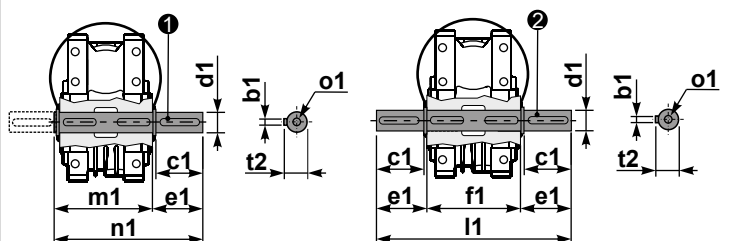

① kit cod. KQ75.5.028 Standard ② kit cod. KQ75.5.029 Standard
kit cod. KQ75.5.026 On request

	ød	e	g	l	m	x	kit code
type B	25 h6	27.8	8	50	109.5	M8x20	KQ75.5.006 PAM80 K085.5.007 PAM90 K085.5.008 PAM100

	b1	c1	d1	e1	f1	l1	m1	n1	t2	o1
Standard	8	60	30 ^{-0.005} _{-0.020}	65	127	255	134	199	33	M8x20
On request	8	60	28 ^{-0.005} _{-0.020}	65	-	-	134	199	31	M8x20



QUICK SELECTION / Selezione veloce

input speed (n_1) = 1400 min⁻¹

Output Speed n_2 [min ⁻¹]	Ratio i	Motor power P_{1M} [kW]	Output torque M_{2M} [Nm]	Service factor f.s.	Nominal power P_{1R} [kW]	Nominal torque M_{2R} [Nm]	Available B5 motor flanges				Available B14 motor flanges			Dynamic efficiency RD	Tooth Module [mm]	Ratios code	
							-C	-D	-E	-F	-R	-T	-U				
							71	80	90	100 112	80	90	100 112				
200	7	4.0	168	1.5	6.1	257		B	B			B	B		88	4.23	01
140	10	4.0	218	1.3	5.2	284		B	B			B	B		80	4.2	02
100	14	3.0	223	1.4	4.1	305		B	B			B	B		78	4.5	03
70	20	2.2	237	1.2	2.7	294		B	B			B	B		79	3.4	04
64	22	2.2	258	1.1	2.5	294		B	B			B	B		78	3.1	05
50	28	2.2	315	1.1	2.4	347		B	B	B		B	B		75	4.7	06
37	38	1.5	276	1.2	1.8	336	B	B				B	B		71	3.5	07
30	46	1.5	320	1.0	1.5	326	B	B				B	B		68	3.1	08
27	52	1.1	258	1.1	1.2	289	B	B				B	B		66	2.7	09
21	67	1.1	327	0.9	0.97	289	B	B				B	B		65	2.1	10
18.9	74	0.75	220	1.2	0.91	268	B	B				B	B		58	1.9	11
14.6	96	0.55	191	1.3	0.70	242	B	B				B	B		53	1.5	12

Motor Flanges Available
Flange Motore Disponibili

B) Supplied with Reduction Bushing
Fornito con Bussola di Riduzione

B) Available on Request without reduction bushing
Disponibile a Richiesta senza Bussola di Riduzione

C) Motor Flange Holes Position
Posizione Fori Flangia Motore

EN Unit Q85 is supplied with synthetic oil, providing "long life" lubrication. For mounting position V5-V6 please contact us. See table 1 for lubrication and recommended quantity. In table 2 please see possible radial loads and axial loads on the gearbox.

I Il riduttore tipo Q85 viene fornito lubrificato a vita con olio sintetico. Per posizioni V5-V6 contattare il ns. servizio tecnico. Vedi tab.1 per oli e quantità consigliati. In tab.2 sono presenti i carichi radiali e assiali applicabili al riduttore.

D Für die Lebensdauerschmierung ist das Getriebe der Größe Q85 mit synthetischem Öl befüllt. Bei Einbaulage V5 oder V6 bitten wir um Rücksprache. In Tabelle 1 ist die Schmiermenge und das empfohlene Schmiermittel angegeben. In Tabelle 2 sind die zulässigen Radial- und Axialbelastungen des Getriebes aufgeführt.

F Le réducteur de type Q85 est fourni lubrifié à vie avec de l'huile synthétique. Concernant les positions V5.V6, contactez notre service d'assistance technique. Voir tableau 1 concernant les huiles et les quantités conseillées. Les charges radiales et axiales applicables au réducteur sont précisées dans le tableau 2.

E El reductor tamaño Q85 se suministra, lubricado de por vida con aceite sintético. Para las posiciones V5 y V6 contactar con nuestro servicio técnico. Ver tabla 1, para cantidades y aceites recomendados. En la tabla 2, se encuentran las cargas radiales y axiales admitidas por el reductor.

LUBRICATION Q85 Oil Quantity 1.20 Lt.

SHELL Omala S4 WE 320

ENI Telium VSF 320

For all details on lubrication and plugs check our website **tab. 1**
Per maggiori dettagli su lubrificazione e tappi olio vedi il nostro sito web

RADIAL AND AXIAL LOADS

Output shaft

Albero di uscita

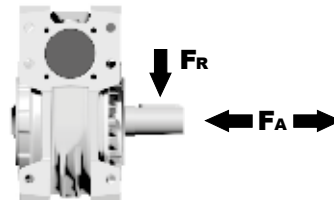

n_2 [min ⁻¹]	FA [N]	FR [N]
200	500	2500
150	580	2900
100	600	3000
75	700	3500
50	800	4000
25	1000	5000
15	1160	5800

Input shaft

albero in entrata

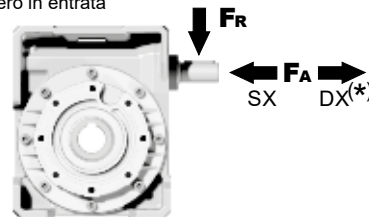

n_1 [min ⁻¹]	FA [N]	FR [N]
1400	130	650

*Strong axial loads in the DX direction are not allowed.
Non sono consentiti forti carichi assiali con direzione DX

tab. 2

PQ85**FB**... Basic wormbox
Riduttore base

Gearbox weight
peso riduttore **12.1 kg**

M. flanges	Kit code	øF	A
71B5	K023.4.041	160	116.5
80/90B5	K023.4.042	200	118.5
100/112B5	K023.4.043	250	127.5
80B14	K085.4.046	120	118.5
90B14	K085.4.045	140	118.5
100/112B14	K085.4.047	160	127.5

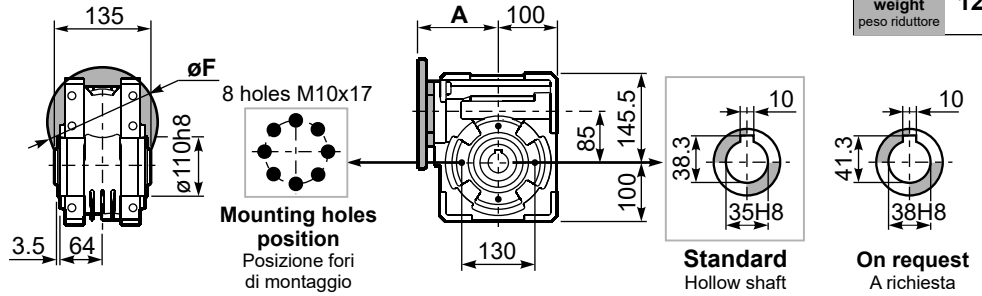

PQ85**FC**... Output flange
Flangia uscita

PQ85**F1**... Output flange
Flangia uscita

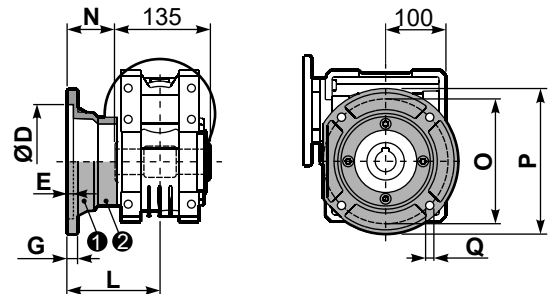
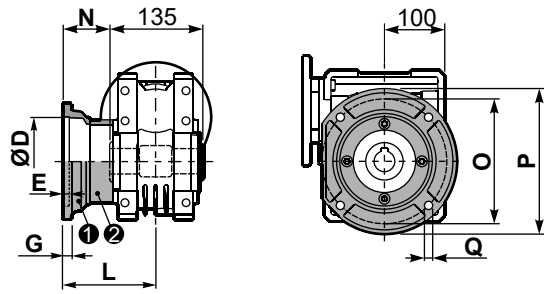

type B	øD	E	G	L	N	O	P	Q	kit code
FC	152 ^{+0.06} / _{+0.00}	5	16	108	40.5	176	205	13	① K085.9.010 ② -
FL	152 ^{+0.06} / _{+0.00}	5	16	148.5	81	176	205	13	① K085.9.010 ② K085.0.201

type S	øD	E	G	L	N	O	P	Q	kit code
F1	130 H7	5	13	117.5	50	165	200	11.5	① KS085.9.012 ② -
F2	152 ^{+0.06} / _{+0.00}	5	15	147.5	80	180	205	12.5	① KS085.9.013 ② -
F4	130 H7	5	13	106.5	39	165	200	13	① KS085.9.015 ② -

PQ85**FB**... Feet
Piedini

PQ85**BR**... Reaction arm
Braccio di reazione

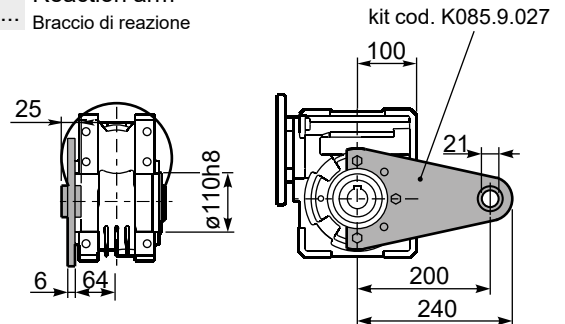
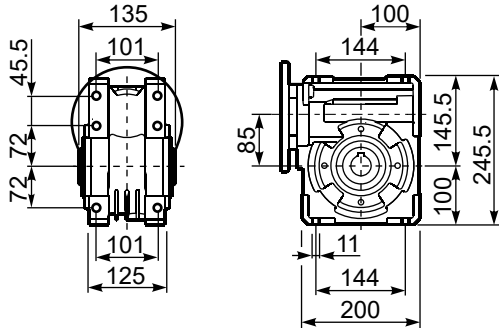

RQ85**FB**... Input shaft
Albero in entrata

PQ85.....**S**... Single Shaft
Albero lento semplice

PQ85.....**D**... Double Shaft
Albero lento bisp.

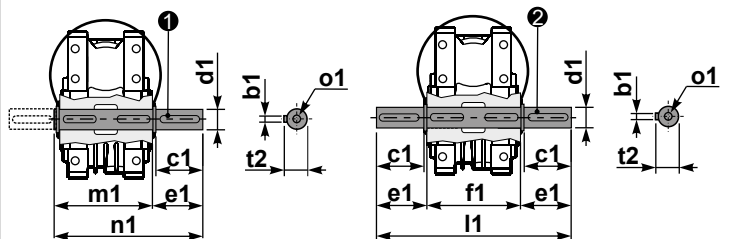
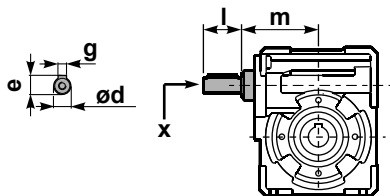

① kit cod. K085.5.028 type B ② kit cod. K085.5.029 type B

	ød	e	g	l	m	x	kit code
type B	25 h6	28	8	50	112	M8x20	① K085.5.007 PAM90 ② K085.5.008 PAM100
type S	24 h6	27	8	50	112	M8x20	① KS085.5.009 PAM90 ② KS085.5.011 PAM100

	b1	c1	d1	e1	f1	l1	m1	n1	t2	o1
type B	10	60	35 ^{-0.005} / _{-0.020}	73.5	135	282	141	214.5	38	M10x23
type S	-	-	-	-	-	-	-	-	-	-



QUICK SELECTION / Selezione veloce

input speed (n_1) = 1400 min⁻¹

Output Speed n_2 [min ⁻¹]	Ratio i	Motor power P_{1M} [kW]	Output torque M_{2M} [Nm]	Service factor f.s.	Nominal power P_{1R} [kW]	Nominal torque M_{2R} [Nm]	Available B5 motor flanges					Available B14 motor flanges				Dynamic efficiency RD	Tooth Module [mm]	Ratios code	
							-C	-D	-E	-F	-G	-R	-T	-U	-V				
							71	80	90	100 112	132	80	90	100 112	132				
200	7	7.5	315	1.5	11.5	483		B	B				B	B			88	5.5	01
140	10	7.5	440	1.2	9.0	525		B	B				B	B			86	5.4	02
88	16	5.5	492	1.1	6.0	536		B	B				B	B			82	5.3	03
70	20	4.0	447	1.2	4.9	546		B	B				B	B			82	4.5	04
61	23	3.0	377	1.4	4.1	515		B	B				B	B			80	3.9	05
47	30	3.0	467	1.4	4.2	651		B	B				B	B			76	5.6	06
37	38	3.0	583	1.1	3.3	641		B	B				B	B			75	4.7	07
31	45	2.2	493	1.2	2.7	599		B	B				B	B			73	4.0	08
26	53	2.2	557	1.1	2.5	620		B	B				B	B			70	3.5	09
22	64	1.5	452	1.2	1.8	536	B	B					B				69	2.9	10
16.7	84	1.1	410	1.2	1.3	494	B	B					B				65	2.2	11
14.1	99	1.1	446	1.1	1.2	483	B	B					B				60	1.9	12

A Motor Flanges Available
Flange Motore Disponibili

B Supplied with Reduction Bushing
Fornito con Bussola di Riduzione

B Available on Request without reduction bushing
Disponibile a Richiesta senza Bussola di Riduzione

C Motor Flange Holes Position
Posizione Fori Flangia Motore

EN Unit Q11 is supplied without lubricant and equipped with a breather, level and drain plugs. User can add mineral oil keeping existing plugs. Should the user wish to fill it with synthetic oil, it is recommended to replace the existing plugs with a closed plug.
See table 1 for lubrication and recommended quantity. In table 2 please see possible radial loads and axial loads on the gearbox.

I Il riduttore tipo Q11 è fornito privo di lubrificazione con tappi di sfiato, livello e scarico olio. L'utente può immettere olio minerale mantenendo i tappi esistenti. Se immetterà olio sintetico, dovrà sostituire i tappi esistenti con altri tipo chiuso.
Tab.1 per oli e quantità consigliati.
Tab.2 carichi radiali e assiali applicabili al riduttore.

D Das Getriebe der Baugröße Q11 wird ohne Schmiermittel geliefert. Es ist jedoch mit Einfüllschraube, Überdruckventil und Ablassschraube ausgerüstet. Das benötigte mineralische Öl kann über die Einfüllschraube eingefüllt werden. Sollte synthetisches Öl bevorzugt werden, so ist sind das eingebaute Überdruckventil durch eine geschlossenen Schraube zu ersetzen.
In Tabelle 1 ist die Schmiermenge und das empfohlene Schmiermittel angegeben
In Tabelle 2 sind die zulässigen Radial - und Axialbelastungen des Getriebes aufgeführt.

F Le réducteur de type Q11 est fourni sans lubrification et avec un bouchon de remplissage, de niveau et d'évacuation de l'huile. L'utilisateur peut y verser de l'huile minérale en conservant les bouchons existants.
S'il y versera de l'huile synthétique, il devra substituer les bouchons existants avec d'autres bouchons de type fermé.
Voir tableau 1 concernant les huiles et les quantités conseillées.
Voir tableau 2 concernant les charges radiales et axiales applicables au réducteur.

E El reductor tamaño Q11 se suministra sin lubricante, provisto de tapones de respiración, nivel y descarga de aceite. El usuario puede utilizar aceite mineral, manteniendo los tapones existentes. Si prefiere utilizar aceite sintético deberá sustituir los tapones existentes por tapones ciegos. La prerreducción se suministra con tapones ciegos, lubricado de por vida con aceite sintético.
Ver tabla 1, para cantidades y aceites recomendados.
En la tabla 2, se encuentran las cargas radiales y axiales admitidas por el reductor.

B3	B6	B7	B8	V5	V6
1.90 LT	1.35 LT	1.35 LT	2.00LT	2.00 LT	2.00LT
SHELL Omala S2 GX 460			ENI Blasias 460		

For all details on lubrication and plugs check our website [www.enigearboxes.com](#) **tab. 1**
Per maggiori dettagli su lubrificazione e tappi olio vedi il nostro sito web

RADIAL AND AXIAL LOADS

Output shaft
Albero di uscita

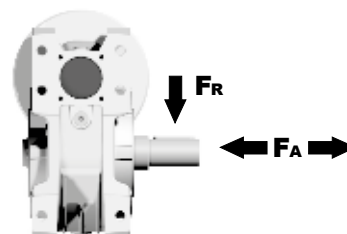

n_2 [min ⁻¹]	FA [N]	FR [N]
200	600	2900
150	700	3300
100	750	3600
75	800	4000
50	920	4600
25	1200	6000
15	1400	7000

Input shaft
albero in entrata

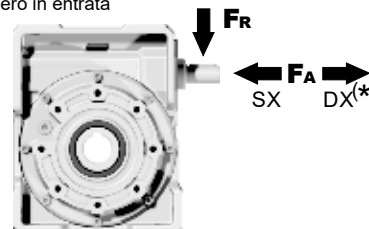

n_1 [min ⁻¹]	FA [N]	FR [N]
1400	228	1140

*Strong axial loads in the DX direction are not allowed.
Non sono consentiti forti carichi assiali con direzione DX

tab. 2

PQ11FB... Basic wormbox
Riduttore base

Gearbox weight
peso riduttore **35.0 kg**

M. flanges	Kit code	øF	A
71B5	K023.4.041	160	136
80/90B5	K023.4.042	200	138
100/112B5	K023.4.043	250	147
132B5	-	300	187
80B14	K085.4.046	120	138
90B14	K085.4.045	140	138
100/112B14	K023.4.041	160	136
132B14	-	200	187

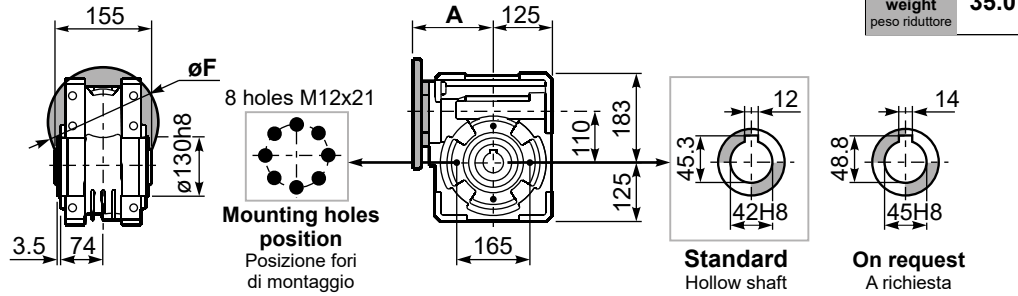

PQ11FC... Output flange
Flangia uscita

PQ11F1... Output flange
Flangia uscita

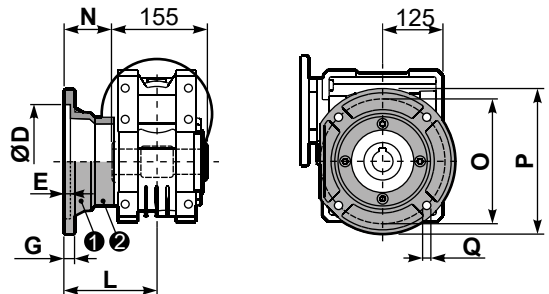
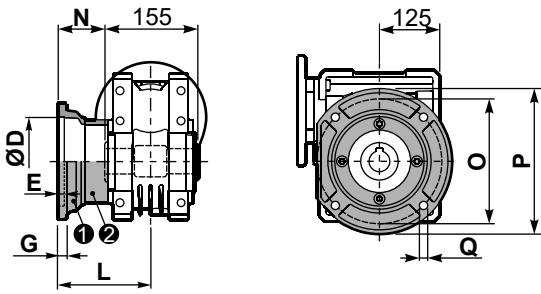

type B	øD	E	G	L	N	O	P	Q	kit code
FC	170 ^{+0.083} / _{+0.043}	11	16.5	131.5	54	230	270	13	① K110.9.010 ② -
FL	170 ^{+0.083} / _{+0.043}	11	16.5	179.5	102	230	270	13	① K110.9.011 ② -

type S	øD	E	G	L	N	O	P	Q	kit code
F1	180 ^{+0.040} / ₀	5	18	150	72.5	215	250	15	① KS110.9.014 ② -
F3	180 ^{+0.040} / ₀	5	18	130	52.5	215	250	15	① KS110.9.013 ② -

PQ11FB... Feet
Piedini

PQ11BR... Reaction arm
Braccio di reazione

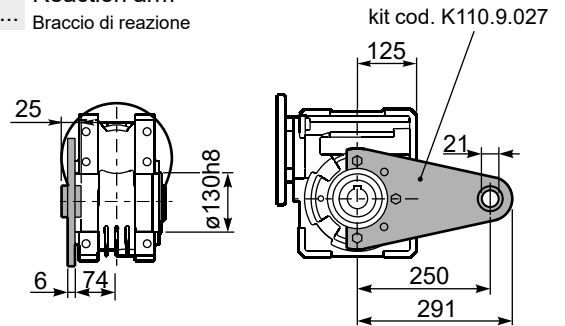
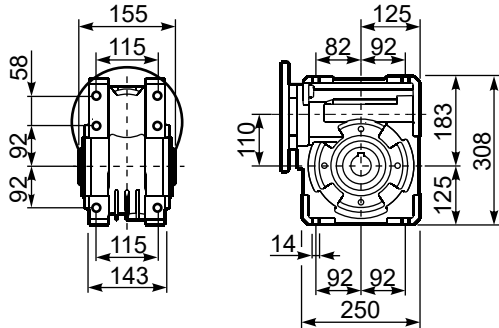

RQ11FB... Input shaft
Albero in entrata

PQ11.....S... Single Shaft
Albero lento semplice

PQ11.....D... Double Shaft
Albero lento bisp.

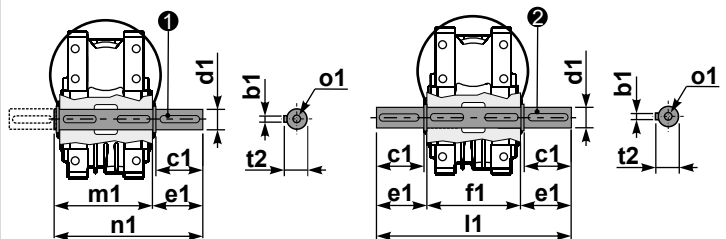
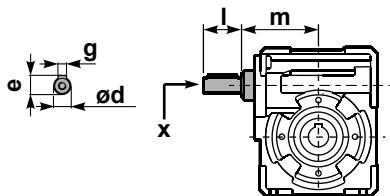

① kit cod. K110.5.028 type B ② kit cod. K110.5.029 type B

	ød	e	g	l	m	x	kit code
type B	25 h6	28	8	50	131.5	M8x20	① K085.5.007 PAM90 ② K085.5.008 PAM100
type S	24 h6	27	8	50	131.5	M8x20	① KS085.5.009 PAM90 ② KS085.5.011 PAM100

	b1	c1	d1	e1	f1	l1	m1	n1	t2	o1
type B	12	75	42 ^{-0.005} / _{-0.020}	96.5	155	348	163.5	260	45	M12x32
type S	-	-	-	-	-	-	-	-	-	-

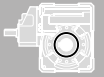

QUICK SELECTION / Selezione veloce

input speed (n_1) = 1400 min⁻¹

	Output Speed n_2 [min ⁻¹]	Ratio i	Motor power P_{1M} [kW]	Output torque M_{2M} [Nm]	Service factor f.s.	Nominal power P_{1R} [kW]	Nominal torque M_{2R} [Nm]	Available B5 motor flanges				Available B14 motor flanges				Dynamic efficiency RD	Tooth Module [mm]	Ratios code
								-B	-C	-D	-E	-P	-Q	-R	-T			
								63	71	80	90	63	71	80	90			
IEC 90 - 80 - 71	47	29.9	0.75	113	1.5	1.1	165						C	C		74	2.6	01
	37	37.7	0.75	141	1.2	0.88	165						C	C		73	2.0	02
	30	47.1	0.75	169	1.1	0.83	187						C	C		70	3.2	03
	25	56.6	0.55	136	1.4	0.76	187						C	C		64	2.7	04
	19.8	70.7	0.55	164	1.1	0.63	187						C	C		62	2.1	05
	15.9	87.8	0.37	162	1.2	0.43	187						C	C		73	2.6	06
	12.6	111.0	0.37	199	0.9	0.35	187						C	C		71	2.0	07
IEC 71 - 63	10.1	139	0.37	234	0.8	0.30	187						C			67	3.2	08
	8.4	166	0.25	173	1.1	0.27	187						C			61	2.7	09
	6.7	208	0.18	151	1.1	0.20	165						C			59	2.1	10
	4.5	310	0.12	129	1.3	0.15	165						C			51	1.5	11
	3.8	370	0.12	145	1.1	0.14	165						C			48	1.3	12
	3.2	434	0.12	149	0.9	0.11	138						C			42	1.1	13

A Motor Flanges Available
Flange Motore Disponibili

B Supplied with Reduction Bushing
Fornito con Bussola di Riduzione

B Available on Request without reduction bushing
Disponibile a Richiesta senza Bussola di Riduzione

C Motor Flange Holes Position
Posizione Fori Flangia Motore

EN Unit P6Q is supplied with synthetic oil, providing "long life" lubrication. For mounting position V5-V6 please contact us. See table 1 for lubrication and recommended quantity. In table 2 please see possible radial loads and axial loads on the gearbox.

I Il riduttore tipo P6Q viene fornito lubrificato a vita con olio sintetico. Per posizioni V5-V6 contattare il ns. servizio tecnico. Vedi tab.1 per oli e quantità consigliati. In tab.2 sono presenti i carichi radiali e assiali applicabili al riduttore.

D Für die Lebensdauerschmierung ist das Getriebe der Größe P6Q mit synthetischem Öl befüllt. Bei Einbaulage V5 oder V6 bitten wir um Rücksprache. In Tabelle 1 ist die Schmiermenge und das empfohlene Schmiermittel angegeben. In Tabelle 2 sind die zulässigen Radial- und Axialbelastungen des Getriebes aufgeführt.

F Le réducteur de type P6Q est fourni lubrifié à vie avec de l'huile synthétique. Concernant les positions V5.V6, contactez notre service d'assistance technique. Voir tableau 1 concernant les huiles et les quantités conseillées. Les charges radiales et axiales applicables au réducteur sont précisées dans le tableau 2.

E El reductor tamaño P6Q se suministra, lubricado de por vida con aceite sintético. Para las posiciones V5 y V6 contactar con nuestro servicio técnico. Ver tabla 1, para cantidades y aceites recomendados. En la tabla 2, se encuentran las cargas radiales y axiales admitidas por el reductor.

LUBRICATION P6Q Oil
For B3-V5-V6 separate lubrication for A (0.30 l) B (0.08 l), for B6-B7-B8 common lubrication 0.35 l (A + B).

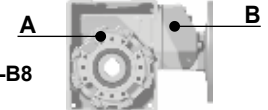

SHELL Omala S4 WE 320

ENI Telium VSF 320

For all details on lubrication and plugs check our website
Per maggiori dettagli su lubrificazione e tappi olio vedi il nostro sito web **tab. 1**

RADIAL AND AXIAL LOADS

Output shaft
Albero di uscita

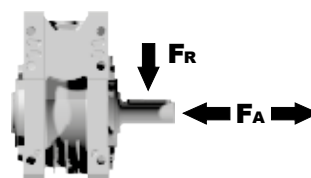

n_2 [min ⁻¹]	FA [N]	FR [N]
75	500	2500
50	600	3000
25	700	3800
15-6	800	4000

Input shaft
albero in entrata

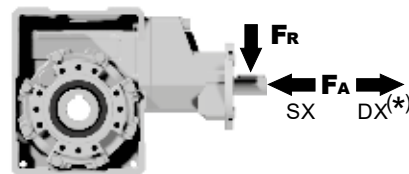

n_1 [min ⁻¹]	FA [N]	FR [N]
1400	61	305

*Strong axial loads in the DX direction are not allowed.
Non sono consentiti forti carichi assiali con direzione DX

tab. 2

PP6QFB... Basic wormbox
Riduttore base

Gearbox weight	29.9+111	139+434
peso riduttore	7.05	6.60
	Kg	Kg

M.flange	Kit code	øF	A
71B5	K063.4.042	160	176.5
80/90B5	K063.4.043	200	178.5
71B14	K063.4.047	105	176.5
80B14	K063.4.046	120	178.5
90B14	K063.4.041	140	178.5
139+434			
63B5	K050.4.041	138	162.5
71B5	K050.4.042	160	160
63B14	K050.4.047	90	162.5
71B14	K050.4.045	105	160

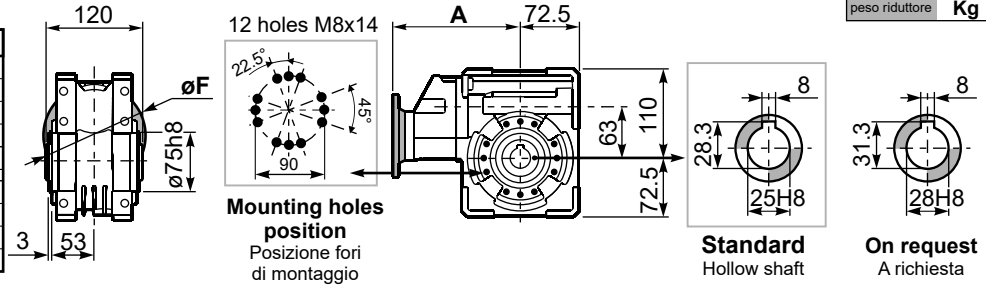

PP6QFC... Output flange
Flangia uscita

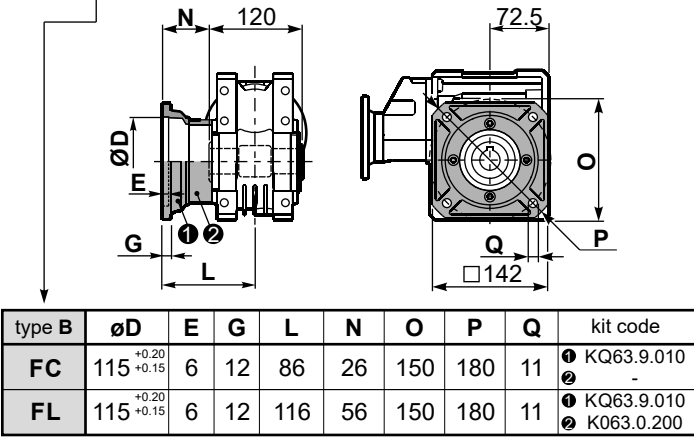

PP6QF1... Output flange
Flangia uscita

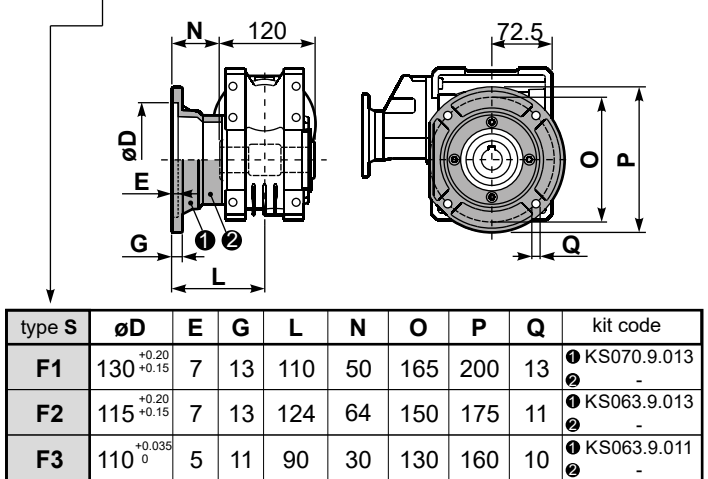

PP6QFB... Feet
Piedini

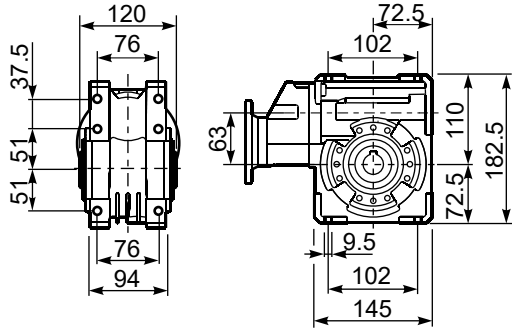

PP6QBR... Reaction arm
Braccio di reazione

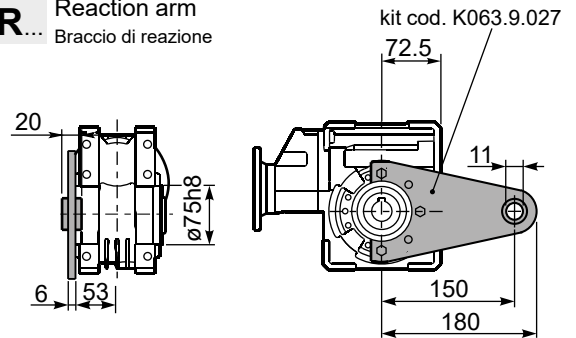

RP6QFB... Input shaft
Albero in entrata

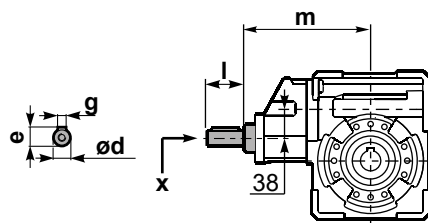

	ød	e	g	l	m	x	
29.9+111	19 h6	21.5	6	35	169	M6x16	C40.5.062
139+434	14 h6	16	5	25	154	M5x13	C35.5.061

PP6Q...S... Single Shaft
Albero lento semplice

PP6Q...D... Double Shaft
Albero lento bisp.

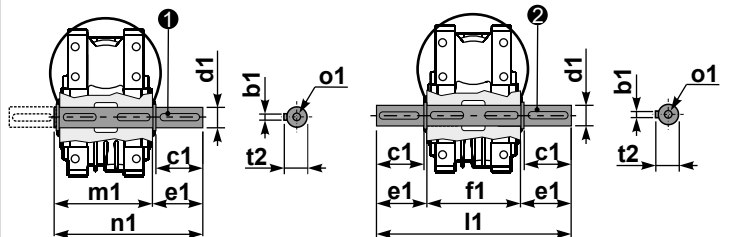

① kit cod. K063.5.028 type B ② kit cod. K063.5.029 type B

	b1	c1	d1	e1	f1	l1	m1	n1	t2	o1
type B	8	60	25 ^{-0.005} / _{-0.020}	63.2	120	246.4	126.8	190	28	M8x20
type S	-	-	-	-	-	-	-	-	-	-

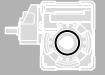

QUICK SELECTION / Selezione veloce

input speed (n₁) = 1400 min⁻¹

Output Speed n ₂ [min ⁻¹]	Ratio i	Motor power P _{1M} [kW]	Output torque M _{2M} [Nm]	Service factor f.s.	Nominal power P _{1R} [kW]	Nominal torque M _{2R} [Nm]	Available B5 motor flanges				Available B14 motor flanges			Dynamic efficiency RD	Tooth Module [mm]	Ratios code
							-B	-C	-D	-E	-Q	-R	-T			
							63	71	80	90	71	80	90			
22	62.9	0.75	248	1.2	0.87	286					C	C		77	3.10	01
18	78.5	0.75	293	1.0	0.73	286					C	C		73	2.41	02
15	94.2	0.75	333	0.9	0.70	310					C	C		69	2.10	03
11	126	0.55	297	1.0	0.55	296	B				C	C		63	1.53	04
9	157	0.37	230	1.1	0.41	252	B				C	C		58	1.23	05
8	185	0.37	257	1.2	0.43	296	B				C	C		55	3.10	06
6	231	0.25	193	1.5	0.38	296	B				C	C		49	2.41	07
5	277	0.25	222	1.3	0.33	296	B				C	C		47	2.10	08
4	378	0.18	200	1.5	0.27	296	B				C	C		43	2.10	09

A Motor Flanges Available
Flange Motore Disponibili

B Supplied with Reduction Bushing
Fornito con Bussola di Riduzione

B Available on Request without reduction bushing
Disponibile a Richiesta senza Bussola di Riduzione

C Motor Flange Holes Position
Posizione Fori Flangia Motore

* Power higher than the maximum one which can be supported by the gearbox. Select according to the torque M_{2R}
Potenza superiore a quella massima sopportabile dal riduttore. Selezionare in base al momento torcente M_{2R}

EN Unit P7Q is supplied with synthetic oil, providing "long life" lubrication. For mounting position V5-V6 please contact us. See table 1 for lubrication and recommended quantity. In table 2 please see possible radial loads and axial loads on the gearbox.

I Il riduttore tipo P7Q viene fornito lubrificato a vita con olio sintetico. Per posizioni V5-V6 contattare il ns. servizio tecnico. Vedi tab.1 per oli e quantità consigliati. In tab.2 sono presenti i carichi radiali e assiali applicabili al riduttore.

D Für die Lebensdauerschmierung ist das Getriebe der Größe P7Q mit synthetischem Öl befüllt. Bei Einbaulage V5 oder V6 bitten wir um Rücksprache. In Tabelle 1 ist die Schmiermenge und das empfohlene Schmiermittel angegeben. In Tabelle 2 sind die zulässigen Radial- und Axialbelastungen des Getriebes aufgeführt.

F Le réducteur de type P7Q est fourni lubrifié à vie avec de l'huile synthétique. Concernant les positions V5.V6, contactez notre service d'assistance technique. Voir tableau 1 concernant les huiles et les quantités conseillées. Les charges radiales et axiales applicables au réducteur sont précisées dans le tableau 2.

E El reductor tamaño P7Q se suministra, lubricado de por vida con aceite sintético. Para las posiciones V5 y V6 contactar con nuestro servicio técnico. Ver tabla 1, para cantidades y aceites recomendados. En la tabla 2, se encuentran las cargas radiales y axiales admitidas por el reductor.

LUBRICATION P7Q Oil

For B3-V5-V6 separate lubrication for A (0.40 l) B (0.14 l), for B6-B7-B8 common lubrication 0.65 l (A + B).

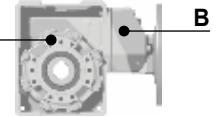

SHELL Omala S4 WE 320

ENI Telium VSF 320

For all details on lubrication and plugs check our website

Per maggiori dettagli su lubrificazione e tappi olio vedi il nostro sito web

tab. 1

RADIAL AND AXIAL LOADS

Output shaft

Albero di uscita

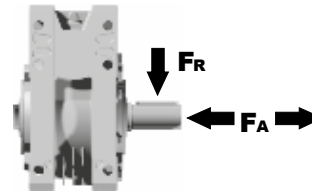

n ₂ [min ⁻¹]	FA [N]	FR [N]
75	620	3100
50	720	3600
25	880	4400
15-6	1000	5000

Input shaft

albero in entrata

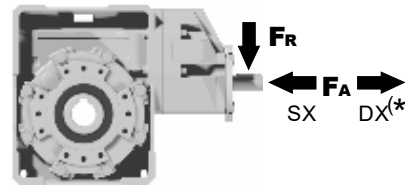

n [min ⁻¹]	FA [N]	FR [N]
1400	108	540

*Strong axial loads in the DX direction are not allowed.

Non sono consentiti forti carichi assiali con direzione DX

tab. 2

PP7Q**FB**... Basic wormbox
Riduttore base

Gearbox weight
peso riduttore **9.90 kg**

M. flanges	Kit code	øF	A
63B5	K063.4.041	140	192.7
71B5	K063.4.042	160	190.7
80/90B5	K063.4.043	200	192.7
71B14	K063.4.047	105	190.7
80B14	K063.4.046	120	192.7
90B14	K063.4.041	140	192.7

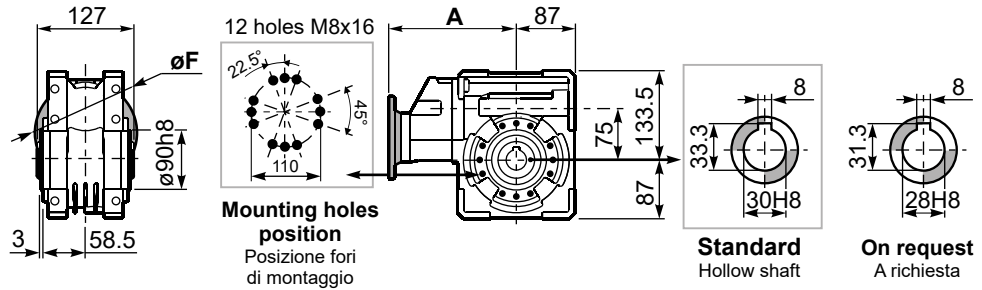

PP7Q**FC**... Square flange
Flangia quadrata

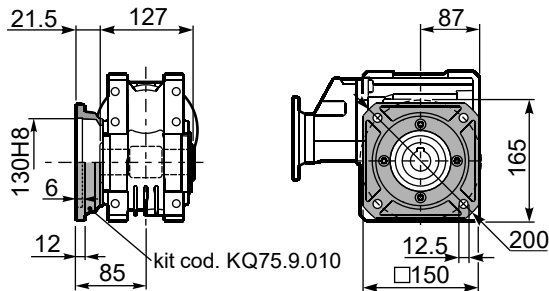

PP7Q**FL**... Square flange
Flangia quadrata

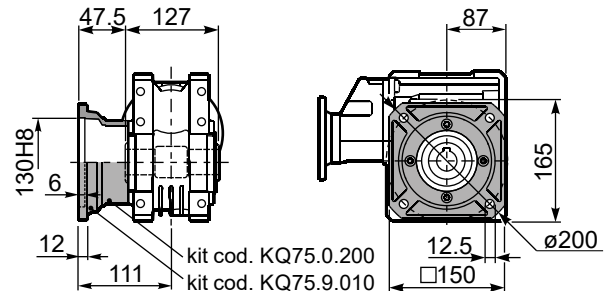

PP7Q**FB**... Feet
Piedini

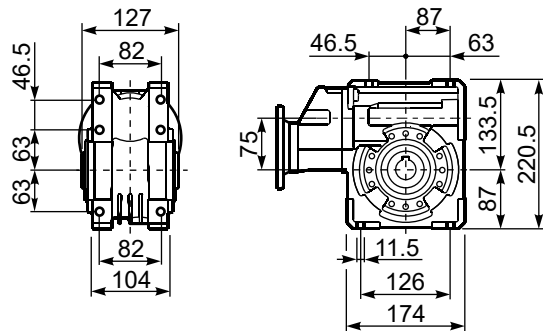

PP7Q**BR**... Reaction arm
Braccio di reazione

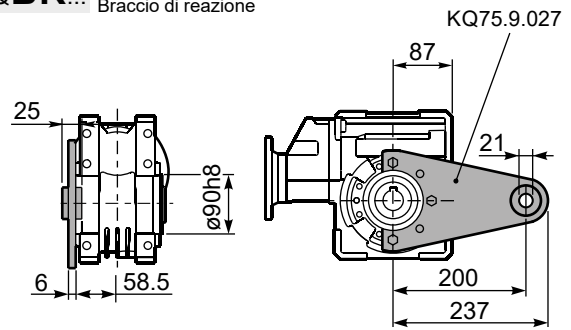

RP7Q**FB**... Input shaft
Albero in entrata

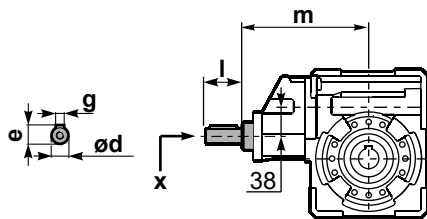

PP7Q.....**S**... Single Shaft
Albero lento semplice

PP7Q.....**D**... Double Shaft
Albero lento bisp.

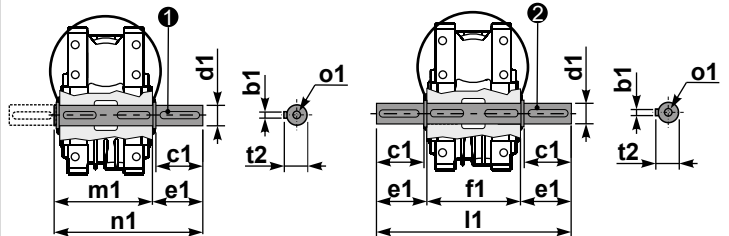

① kit cod. KQ75.5.028 Standard
kit cod. KQ75.5.026 On request

② kit cod. KQ75.5.029 Standard

	ød	e	g	l	m	x	
type B	19 h6	21.5	6	35	185.5	M6x16	C40.5.062
type S	-	-	-	-	-	-	

	b1	c1	d1	e1	f1	l1	m1	n1	t2	o1
Standard	8	60	30 ^{-0.005} _{-0.020}	65	127	255	134	199	33	M8x20
On request	8	50	28 ^{-0.005} _{-0.020}	65	-	-	134	199	31	M8x20

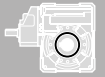

QUICK SELECTION / Selezione veloce

input speed (n_1) = 1400 min⁻¹

Output Speed n_2 [min ⁻¹]	Ratio i	Motor power P_{1M} [kW]	Output torque M_{2M} [Nm]	Service factor f.s.	Nominal power P_{1R} [kW]	Nominal torque M_{2R} [Nm]	Available B5 motor flanges				Available B14 motor flanges			Dynamic efficiency RD	Tooth Module [mm]	Ratios code
							-B	-C	-D	-E	-Q	-R	-T			
							63	71	80	90	71	80	90			
23.5	59.7	1.1	300	1.4	1.5	418					C	C		67	3.5	01
19.4	72.3	1.1	347	1.2	1.3	407					C	C		64	3.1	02
17.1	81.7	1.1	374	1.1	1.2	418					C	C		61	2.7	03
13.3	105	0.75	323	1.2	0.89	385					C	C		60	2.1	04
8.0	176	0.55	415	1.1	0.58	440	B				C	C		63	3.5	05
6.6	213	0.37	322	1.3	0.47	407	B				C	C		60	3.1	06
5.8	240	0.37	321	1.3	0.48	418	B				C	C		53	2.7	07
4.3	328	0.37	438	1.0	0.35	418	B				C	C		53	2.7	08
3.3	422	0.25	374	1.0	0.26	385	B				C	C		52	2.1	09
3.0	466	0.25	358	0.9	0.23	330	B				C	C		45	1.9	10
2.3	605	0.18	297	1.1	0.20	330	B				C	C		40	1.5	11

A Motor Flanges Available
Flange Motore Disponibili

B Supplied with Reduction Bushing
Fornito con Bussola di Riduzione

B Available on Request without reduction bushing
Disponibile a Richiesta senza Bussola di Riduzione

C Motor Flange Holes Position
Posizione Fori Flangia Motore

EN Unit **P8Q** is supplied with synthetic oil, providing "long life" lubrication. For mounting position V5-V6 please contact us. See table 1 for lubrication and recommended quantity. In table 2 please see possible radial loads and axial loads on the gearbox.

I Il riduttore tipo **P8Q** viene fornito lubrificato a vita con olio sintetico. Per posizioni V5-V6 contattare il ns. servizio tecnico. Vedi tab.1 per oli e quantità consigliati. In tab.2 sono presenti i carichi radiali e assiali applicabili al riduttore.

D Für die Lebensdauerschmierung ist das Getriebe der Größe **P8Q** mit synthetischem Öl befüllt. Bei Einbaulage V5 oder V6 bitten wir um Rücksprache. In Tabelle 1 ist die Schmiermenge und das empfohlene Schmiermittel angegeben. In Tabelle 2 sind die zulässigen Radial- und Axialbelastungen des Getriebes aufgeführt.

F Le réducteur de type **P8Q** est fourni lubrifié à vie avec de l'huile synthétique. Concernant les positions V5.V6, contactez notre service d'assistance technique. Voir tableau 1 concernant les huiles et les quantités conseillées. Les charges radiales et axiales applicables au réducteur sont précisées dans le tableau 2.

E El reductor tamaño **P8Q** se suministra, lubricado de por vida con aceite sintético. Para las posiciones V5 y V6 contactar con nuestro servicio técnico. Ver tabla 1, para cantidades y aceites recomendados. En la tabla 2, se encuentran las cargas radiales y axiales admitidas por el reductor.

LUBRICATION P8Q Oil

For B3-V5-V6 separate lubrication for A (1.20 l) B (0.14 l) , for B6-B7-B8 common lubrication 1.00 l (A + B).

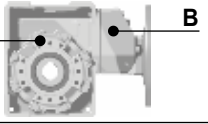

SHELL Omala S4 WE 320 **ENI** Telium VSF 320

For all details on lubrication and plugs check our website **tab. 1**
Per maggiori dettagli su lubrificazione e tappi olio vedi il nostro sito web

RADIAL AND AXIAL LOADS

Output shaft
Albero di uscita

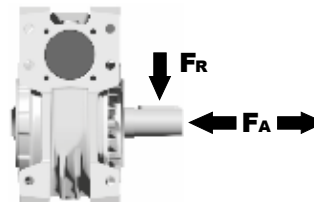

n_2 [min ⁻¹]	FA [N]	FR [N]
75	700	3500
50	800	4000
25	1000	5000
15-6	1160	5800

Input shaft
albero in entrata

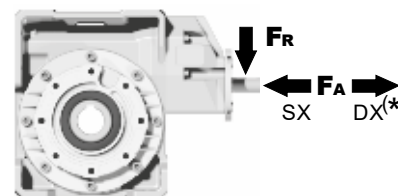

n_1 [min ⁻¹]	FA [N]	FR [N]
1400	108	540

*Strong axial loads in the DX direction are not allowed.
Non sono consentiti forti carichi assiali con direzione DX

tab. 2

PP8Q**FB**... Basic wormbox
Riduttore base

Gearbox weight
peso riduttore **12.3 kg**

M. flanges	Kit code	øF	A
63B5	K063.4.041	140	195.2
71B5	K063.4.042	160	193.2
80/90B5	K063.4.043	200	195.2
71B14	K063.4.047	105	193.2
80B14	K063.4.046	120	195.2
90B14	K063.4.041	140	195.2

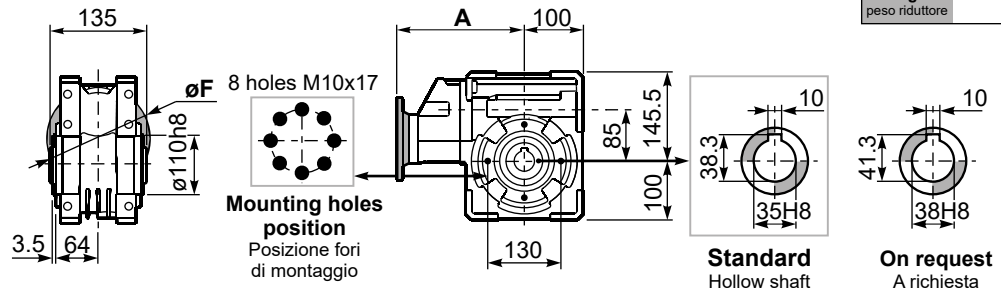

PP8Q**FC**... Output flange
Flangia uscita

PP8Q**F1**... Output flange
Flangia uscita

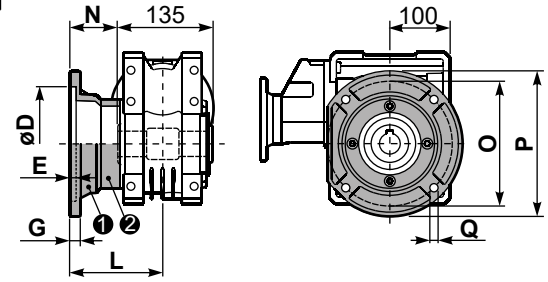
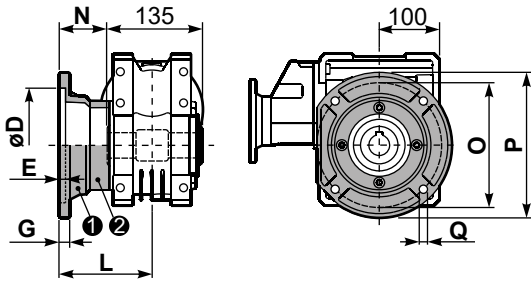

type B	øD	E	G	L	N	O	P	Q	kit code
FC	152 ^{+0.06} / _{+0.00}	5	16	108	40.5	176	205	13	1 K085.9.010 2 -
FL	152 ^{+0.06} / _{+0.00}	5	16	148.5	81	176	205	13	1 K085.9.010 2 K085.0.201

type S	øD	E	G	L	N	O	P	Q	kit code
F1	130 ^{+0.04} / _{+0.00}	5	13	117.5	50	165	200	11.5	1 KS085.9.012 2 -
F2	152 ^{+0.06} / _{+0.00}	5	15	147.5	80	180	205	12.5	1 KS085.9.013 2 -
F4	130 ^{+0.04} / _{+0.00}	5	13	106.5	39	165	200	13	1 KS085.9.015 2 -

PP8Q**FB**... Feet
Piedini

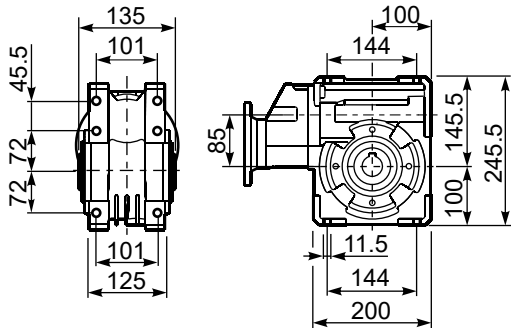

PP8Q**BR**... Reaction arm
Braccio di reazione

kit cod. K085.9.027

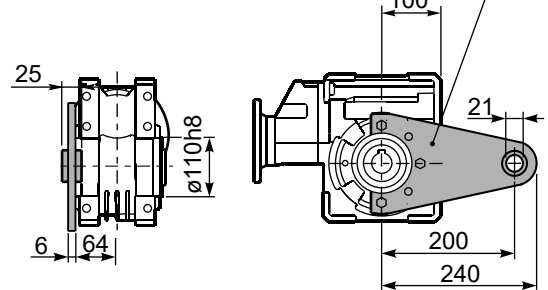

RP8Q**FB**... Input shaft
Albero in entrata

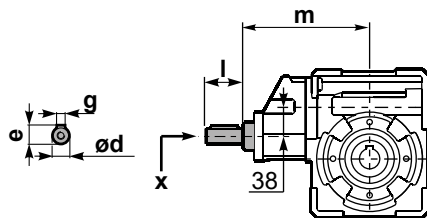

PP8Q...**S**... Single Shaft
Albero lento semplice

PP8Q...**D**... Double Shaft
Albero lento bisp.

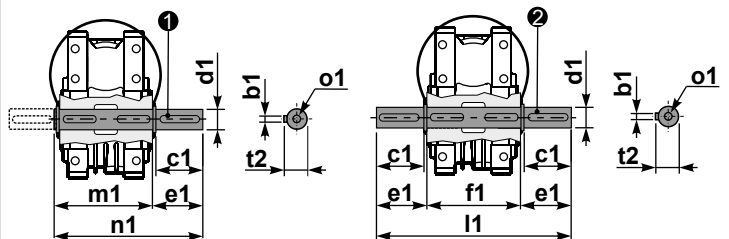

1 kit cod. K085.5.028 type B

2 kit cod. K085.5.029 type B

	ød	e	g	l	m	x	
type B	19 h6	21.5	6	35	186	M6x16	C40.5.062
type S	-	-	-	-	-	-	-

	b1	c1	d1	e1	f1	l1	m1	n1	t2	o1
type B	10	60	35 ^{-0.005} / _{-0.020}	73.5	135	282	141	214.5	38	M10x23
type S	-	-	-	-	-	-	-	-	-	-

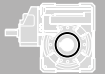

QUICK SELECTION / Selezione veloce

input speed (n_1) = 1400 min⁻¹

Output Speed n_2 [min ⁻¹]	Ratio i	Motor power P_{1M} [kW]	Output torque M_{2M} [Nm]	Service factor f.s.	Nominal power P_{1R} [kW]	Nominal torque M_{2R} [Nm]	Available B5 motor flanges				Available B14 motor flanges			Dynamic efficiency RD	Tooth Module [mm]	Ratios code
							-B	-C	-D	-E	-Q	-R	-T			
							63	71	80	90	71	80	90			
16.8	83.2	1.5	587	1.1	1.7	660					C	C		69	3.5	01
13.9	100.5	1.5	699	0.8	1.3	594					C	C		68	2.9	02
10.6	132	1.1	634	0.9	0.95	550					C	C		64	2.2	03
8.0	176	0.75	666	1.2	0.90	803	B				C	C		74	4.7	04
6.7	208	0.75	766	0.9	0.65	660	B				C	C		72	4.0	05
5.7	245	0.55	634	1.0	0.57	660	B				C	C		69	3.5	06
4.7	296	0.55	755	0.8	0.43	594	B				C	C		68	2.9	07
4.2	334	0.55	865	0.8	0.42	660	B				C	C		69	3.5	08
3.5	403	0.37	692	0.9	0.32	594	B				C	C		68	2.9	09
2.6	529	0.25	577	1.0	0.24	550	B				C	C		64	2.2	10
2.2	624	0.25	628	0.8	0.21	528	B				C	C		59	1.9	11

Motor Flanges Available
Flange Motore Disponibili

B) Supplied with Reduction Bushing
Fornito con Bussola di Riduzione

B) Available on Request without reduction bushing
Disponibile a Richiesta senza Bussola di Riduzione

C) Motor Flange Holes Position
Posizione Fori Flangia Motore

EN Unit **P1Q** is supplied without lubricant and equipped with a breather, level and drain plugs. User can add mineral oil keeping existing plugs. Should the user wish to fill it with synthetic oil, it is recommended to replace the existing plugs with a closed plug. Primary reduction unit is supplied with closed plugs and lubricated for life with synthetic oil. See table 1 for lubrication and recommended quantity. In table 2 please see possible radial loads and axial loads on the gearbox.

I Il riduttore tipo **P1Q** è fornito privo di lubrificazione con tappi di sfiato, livello e scarico olio. L'utente può immettere olio minerale mantenendo i tappi esistenti. Se immetterà olio sintetico, dovrà sostituire i tappi esistenti con altri tipo chiuso. La precoppia è fornita con tappi chiusi e lubrificata a vita con olio sintetico. Tab.1 per oli e quantità consigliati. Tab.2 carichi radiali e assiali applicabili al riduttore.

D Das Getriebe der Baugröße **P1Q** wird ohne Schmiermittel geliefert. Es ist jedoch mit Einfüllschraube, Überdruckventil und Ablassschraube ausgerüstet. Das benötigte mineralische Öl kann über die Einfüllschraube eingefüllt werden. Sollte synthetisches Öl bevorzugt werden, so ist sind das eingebaute Überdruckventil durch eine geschlossenen Schraube zu ersetzen. Die Stirnradvorstufe ist Lebensdauer geschmiert und wird mit synthetischem Öl geliefert. Die Stirnradvorstufe ist komplett geschlossen ohne Füllschrauben. In Tabelle 1 ist die Schmiermenge und das empfohlene Schmiermittel angegeben. In Tabelle 2 sind die zulässigen Radial- und Axialbelastungen des Getriebes aufgeführt.

F Le réducteur de type **P1Q** est fourni sans lubrification et avec un bouchon de remplissage, de niveau et d'évacuation de l'huile. L'utilisateur peut y verser de l'huile minérale en conservant les bouchons existants. S'il y versera de l'huile synthétique, il devra substituer les bouchons existants avec d'autres bouchons de type fermé. Le pré couple est fourni lubrifié à vie avec de l'huile synthétique et avec des bouchons fermés. Voir tableau 1 concernant les huiles et les quantités conseillées. Voir tableau 2 concernant les charges radiales et axiales applicables au réducteur.

E El reductor tamaño **P1Q** se suministra sin lubricante, provisto de tapones de respiración, nivel y descarga de aceite. El usuario puede utilizar aceite mineral, manteniendo los tapones existentes. Si prefiere utilizar aceite sintético deberá sustituir los tapones existentes por tapones ciegos. La prerreducción se suministra con tapones ciegos, lubricado de por vida con aceite sintético. Ver tabla 1, para cantidades y aceites recomendados. En la tabla 2, se encuentran las cargas radiales y axiales admitidas por el reductor.

B3	B6	B7	B8	V5	V6
1.9/0.14LT	1.35/0.14 LT	1.35/0.14 LT	2.0/0.14 LT	2.0/0.14 LT	2.0/0.14 LT
SHELL Omala S2 GX 460			ENI Blasias 460		

For all details on lubrication and plugs check our website **tab. 1**
Per maggiori dettagli su lubrificazione e tappi olio vedi il nostro sito web

RADIAL AND AXIAL LOADS

Output shaft

Albero di uscita

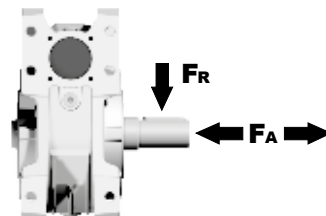

n_2 [min ⁻¹]	FA [N]	FR [N]
75	800	4000
50	920	4600
25	1200	6000
15-6	1400	7000

Input shaft

albero in entrata

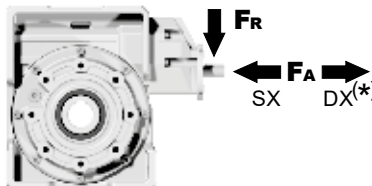

n_1 [min ⁻¹]	FA [N]	FR [N]
1400	150	760

***Strong axial loads in the DX direction are not allowed.**
Non sono consentiti forti carichi assiali con direzione DX

tab. 2

PP1Q**FB**... Basic wormbox
Riduttore base

Gearbox weight
peso riduttore **37.3 kg**

M. flanges	Kit code	øF	A
63B5	K063.4.041	140	214.7
71B5	K063.4.042	160	212.7
80/90B5	K063.4.043	200	214.7
71B14	K063.4.047	105	212.7
80B14	K063.4.046	120	214.7
90B14	K063.4.041	140	214.7

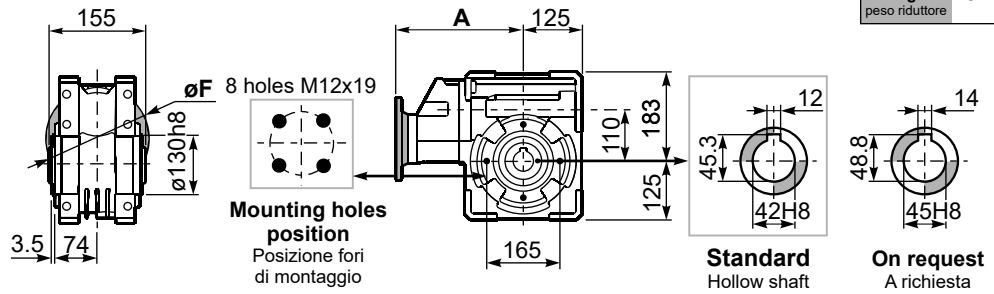

PP1Q**FC**... Output flange
Flangia uscita

PP1Q**F1**... Output flange
Flangia uscita

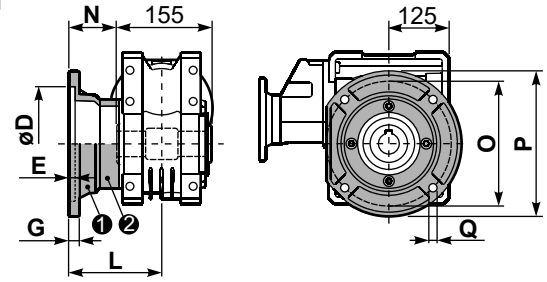
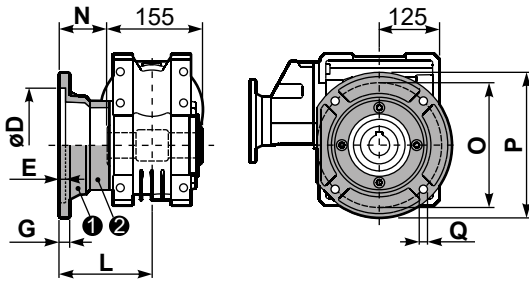

type B	øD	E	G	L	N	O	P	Q	kit code
FC	170 ^{+0.083} / _{-0.043}	11	16.5	131.5	54	230	270	13	1 K110.9.010 2 -
FL	170 ^{+0.083} / _{-0.043}	11	16.5	179.5	102	230	270	13	1 K110.9.011 2 -

type S	øD	E	G	L	N	O	P	Q	kit code
F1	180 ^{+0.040} / ₀	5	18	150	72.5	215	250	15	1 KS110.9.014 2 -
F3	180 ^{+0.040} / ₀	5	18	130	52.5	215	250	15	1 KS110.9.013 2 -

PP1Q**FB**... Feet
Piedini

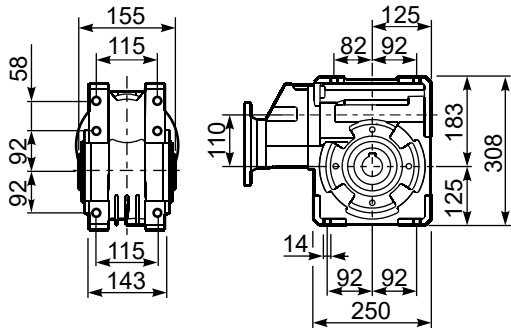

PP1Q**BR**... Reaction arm
Braccio di reazione

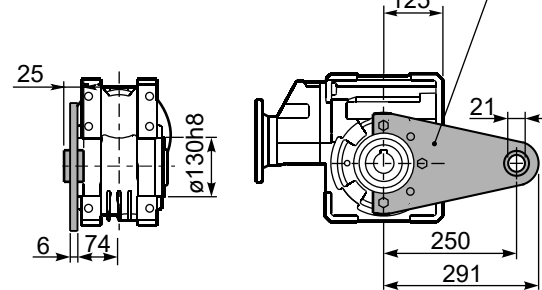

RP1Q**FB**... Input shaft
Albero in entrata

PP1Q...**S**... Single Shaft
Albero lento semplice

PP1Q...**D**... Double Shaft
Albero lento bisp.

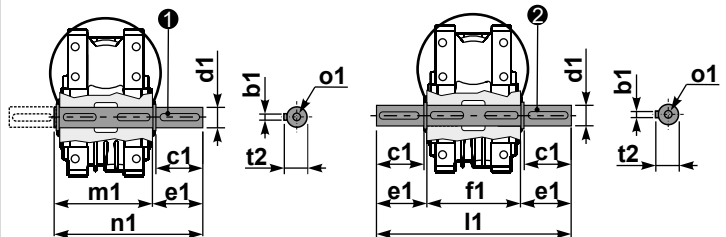
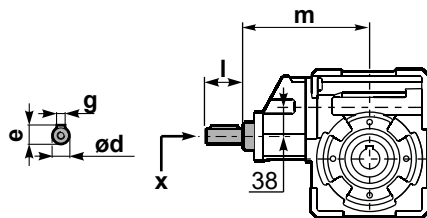

	ød	e	g	l	m	x	
type B	19 h6	21.5	6	35	205	M6x16	C40.5.062
type S	-	-	-	-	-	-	-

	b1	c1	d1	e1	f1	l1	m1	n1	t2	o1
type B	12	75	42 ^{-0.005} / _{-0.020}	96.5	155	348	163.5	260	45	M12x32
type S	-	-	-	-	-	-	-	-	-	-

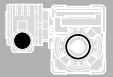

QUICK SELECTION / Selezione veloce

input speed (n_1) = 1400 min⁻¹

Output Speed n_2 [min ⁻¹]	Ratio i	Motor power P_{1M} [kW]	Output torque M_{2M} [Nm]	Service factor f.s.	Nominal power P_{1R} [kW]	Nominal torque M_{2R} [Nm]	Available B5 motor flanges		Available B14 motor flanges		Dynamic efficiency RD	Tooth Module [mm]	 Ratios code
							-A	-B	-O	-P			
							56	63	56	63			
5.6	252	0.18	142	1.6	0.29	230	B		B-C		46	2.7	01
3.9	360	0.18	181	1.3	0.23	230	B		B-C		41	2.7	02
2.6	540	0.12	164	1.4	0.17	230	B		B-C		37	2.7	03
1.9	720	0.12	200	1.1	0.14	230	B		B-C		34	2.7	04
1.3	1080	0.12	265	0.9	0.10	230	B		B-C		30	2.7	05
1.0	1440	0.12*	230	<0.8	0.09	230	B		B-C		27	2.7	06
0.5	2745	0.12*	230	<0.8	0.05	230	B		B-C		23	2.1	07

A) Motor Flanges Available
Flange Motore Disponibili

B) Supplied with Reduction Bushing
Fornito con Bussola di Riduzione

B) Available on Request without reduction bushing
Disponibile a Richiesta senza Bussola di Riduzione

C) Motor Flange Holes Position
Posizione Fori Flangia Motore

* Power higher than the maximum one which can be supported by the gearbox. Select according to the torque M_{2R}
Potenza superiore a quella massima sopportabile dal riduttore. Selezionare in base al momento torcente M_{2R}

EN Unit **63Q** is supplied with synthetic oil, providing "long life" lubrication. For mounting position V5-V6 please contact us. See table 1 for lubrication and recommended quantity. In table 2 please see possible radial loads and axial loads on the gearbox.

I Il riduttore tipo **63Q** viene fornito lubrificato a vita con olio sintetico. Per posizioni V5-V6 contattare il ns. servizio tecnico. Vedi tab.1 per oli e quantità consigliati. In tab.2 sono presenti i carichi radiali e assiali applicabili al riduttore.

D Für die Lebensdauerschmierung ist das Getriebe der Größe **63Q** mit synthetischem Öl befüllt. Bei Einbaulage V5 oder V6 bitten wir um Rücksprache. In Tabelle 1 ist die Schmiermenge und das empfohlene Schmiermittel angegeben. In Tabelle 2 sind die zulässigen Radial- und Axialbelastungen des Getriebes aufgeführt.

F Le réducteur de type **63Q** est fourni lubrifié à vie avec de l'huile synthétique. Concernant les positions V5.V6, contactez notre service d'assistance technique. Voir tableau 1 concernant les huiles et les quantités conseillées. Les charges radiales et axiales applicables au réducteur sont précisées dans le tableau 2.

E El reductor tamaño **63Q** se suministra, lubricado de por vida con aceite sintético. Para las posiciones V5 y V6 contactar con nuestro servicio técnico. Ver tabla 1, para cantidades y aceites recomendados. En la tabla 2, se encuentran las cargas radiales y axiales admitidas por el reductor.

0.30 Lt.

LUBRICATION 63Q Oil
Quantity 0.30/0.03 Lt.

0.03 Lt.

SHELL Omala S4 WE 320	ENI Telium VSF 320
------------------------------	---------------------------

For all details on lubrication and plugs check our website **tab. 1**
Per maggiori dettagli su lubrificazione e tappi olio vedi il nostro sito web

RADIAL AND AXIAL LOADS

Output shaft
Albero di uscita

Input shaft
albero in entrata

n_2 [min ⁻¹]	FA [N]	FR [N]
25	700	3800
15	800	4000

n_1 [min ⁻¹]	FA [N]	FR [N]
1400	20	100

*Strong axial loads in the DX direction are not allowed.
Non sono consentiti forti carichi assiali con direzione DX

tab. 2

P63QFB... Basic wormbox
Riduttore base

Gearbox weight
peso riduttore **7.25 kg**

M. flanges	Kit code	øF	A
56B5	K030.4.041	120	61.5
63B5	K030.4.042	140	62.5
56B14	K030.4.046	80	61.5
63B14	K030.4.045	90	62.5

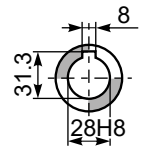
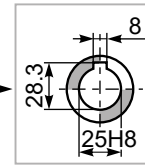
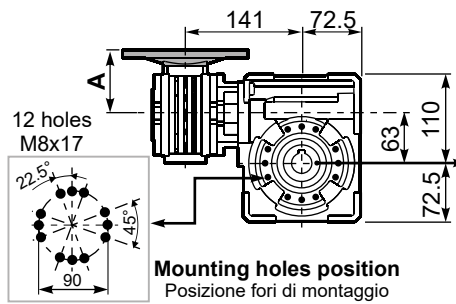
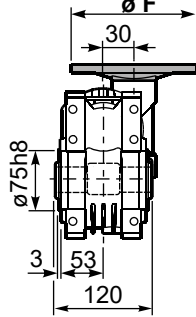

Mounting holes position
Posizione fori di montaggio

Standard
Hollow shaft

On Request
A richiesta

P63QFC... Square flange
Flangia quadrata

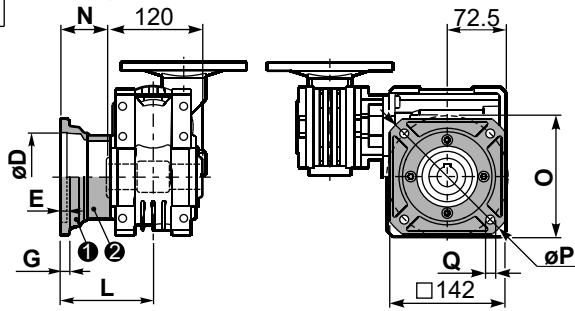

P63QF1... Round flange
Flangia rotonda

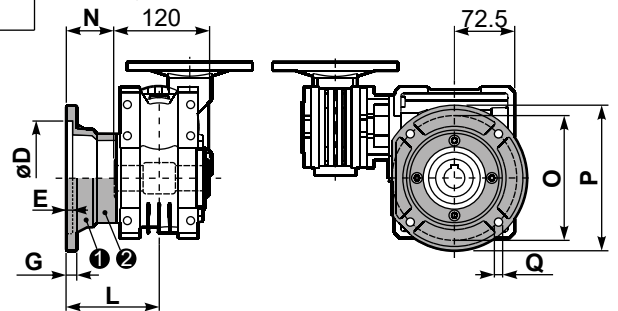

type B	øD	E	G	L	N	O	P	Q	kit code
FC	115 ^{+0.20} / _{+0.15}	6	12	86	26	150	180	11	① KQ63.9.010 ② -
FL	115 ^{+0.20} / _{+0.15}	6	12	116	56	150	180	11	① KQ63.9.010 ② K063.0.200

type S	øD	E	G	L	N	O	P	Q	kit code
F1	130 ^{+0.20} / _{+0.15}	7	13	110	50	165	200	13	① KS070.9.013 ② -
F2	115 ^{+0.20} / _{+0.15}	7	13	124	64	150	175	11	① KS063.9.013 ② -
F3	110 ^{+0.035} / ₀	5	11	90	30	130	160	10	① KS063.9.011 ② -

P63QFB... Feet
Piedini

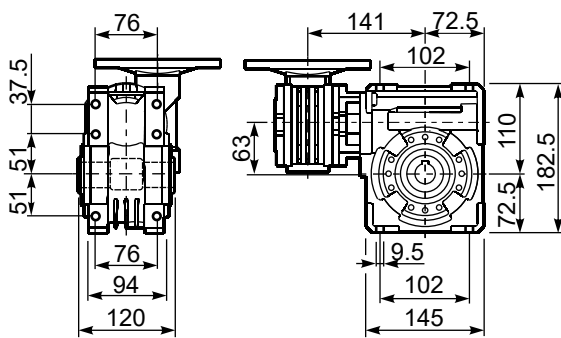

P63QBR... Reaction arm
Braccio di reazione

kit cod. K063.9.027

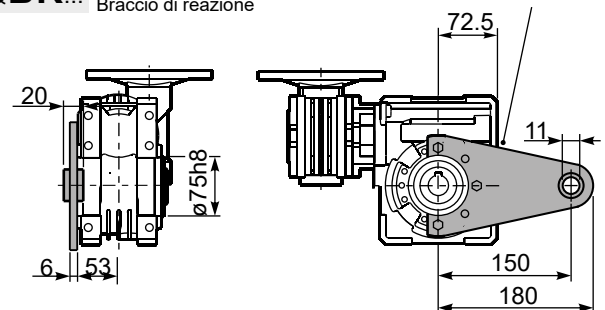

R63QFB... Input shaft
Albero in entrata

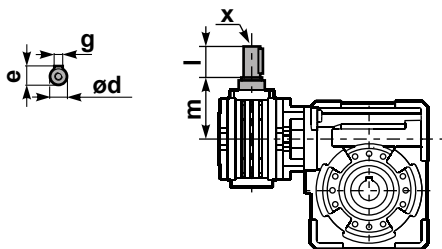

P63Q.....S... Single Shaft
Albero lento semplice

P63Q.....D... Double Shaft
Albero lento bisp.

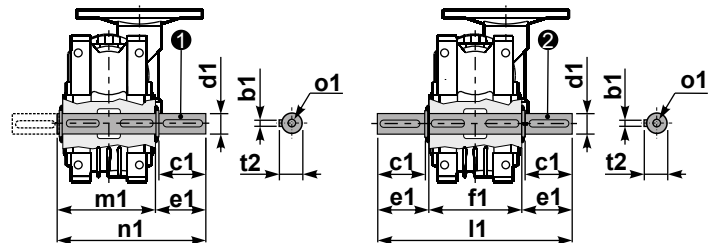

① kit cod. K063.5.028 type B

② kit cod. K063.5.029 type B

	ød	e	g	l	m	x	kit code
type B	9 h6	10.2	3	20	58	-	① K030.5.006 PAM63 ② -
type S	-	-	-	-	-	-	① - ② -

	b1	c1	d1	e1	f1	l1	m1	n1	t2	o1
type B	8	60	25 ^{-0.005} / _{-0.020}	63.2	120	246.4	126.8	190	28	M8x20
type S	-	-	-	-	-	-	-	-	-	-

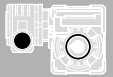

QUICK SELECTION / Selezione veloce

input speed (n₁) = 1400 min⁻¹

Output Speed n ₂ [min ⁻¹]	Ratio i	Motor power P _{1M} [kW]	Output torque M _{2M} [Nm]	Service factor f.s.	Nominal power P _{1R} [kW]	Nominal torque M _{2R} [Nm]	Available B5 motor flanges		Available B14 motor flanges			Dynamic efficiency RD	Tooth Module [mm]	Ratios code
							-B	-C	-O	-P	-Q			
5.6	252	0.25	198	1.3	0.33	265	B		B-C	B-C		46	2.7	01
3.9	360	0.18	186	1.4	0.26	265	B		B-C	B-C		42	2.7	02
2.8	504	0.18	241	1.1	0.20	265	B		B-C	B-C		39	2.7	03
1.9	756	0.12	204	1.3	0.16	265	B		B-C	B-C		33	2.7	04
1.4	1008	0.12	256	1.0	0.12	265	B		B-C	B-C		31	2.7	05
1.1	1332	0.12*	265	<0.8	0.10	265	B		B-C	B-C		30	2.7	06
0.8	1656	0.12*	265	<0.8	0.08	265	B		B-C	B-C		28	2.7	07
0.6	2160	0.12*	265	<0.8	0.07	265	B		B-C	B-C		26	2.7	08
0.6	2520	0.12*	265	<0.8	0.06	265	B		B-C	B-C		25	2.7	09

A) Motor Flanges Available
Flange Motore Disponibili

B) Supplied with Reduction Bushing
Fornito con Bussola di Riduzione

B) Available on Request without reduction bushing
Disponibile a Richiesta senza Bussola di Riduzione

C) Motor Flange Holes Position
Posizione Fori Flangia Motore

* Power higher than the maximum one which can be supported by the gearbox. Select according to the torque M_{2R}
Potenza superiore a quella massima sopportabile dal riduttore. Selezionare in base al momento torcente M_{2R}

EN Unit **64Q** is supplied with synthetic oil, providing "long life" lubrication. For mounting position V5-V6 please contact us. See table 1 for lubrication and recommended quantity. In table 2 please see possible radial loads and axial loads on the gearbox.

I Il riduttore tipo **64Q** viene fornito lubrificato a vita con olio sintetico. Per posizioni V5-V6 contattare il ns. servizio tecnico. Vedi tab.1 per oli e quantità consigliati. In tab.2 sono presenti i carichi radiali e assiali applicabili al riduttore.

D Für die Lebensdauerschmierung ist das Getriebe der Größe **64Q** mit synthetischem Öl befüllt. Bei Einbaulage V5 oder V6 bitten wir um Rücksprache. In Tabelle 1 ist die Schmiermenge und das empfohlene Schmiermittel angegeben. In Tabelle 2 sind die zulässigen Radial- und Axialbelastungen des Getriebes aufgeführt.

F Le réducteur de type **64Q** est fourni lubrifié à vie avec de l'huile synthétique. Concernant les positions V5.V6, contactez notre service d'assistance technique. Voir tableau 1 concernant les huiles et les quantités conseillées. Les charges radiales et axiales applicables au réducteur sont précisées dans le tableau 2.

E El reductor tamaño **64Q** se suministra, lubricado de por vida con aceite sintético. Para las posiciones V5 y V6 contactar con nuestro servicio técnico. Ver tabla 1, para cantidades y aceites recomendados. En la tabla 2, se encuentran las cargas radiales y axiales admitidas por el reductor.

LUBRICATION 64Q Oil
Quantity 0.30/0.09 Lt.

SHELL Omala S4 WE 320

ENI Telium VSF 320

For all details on lubrication and plugs check our website **tab. 1**
Per maggiori dettagli su lubrificazione e tappi olio vedi il nostro sito web

RADIAL AND AXIAL LOADS

Output shaft

Albero di uscita

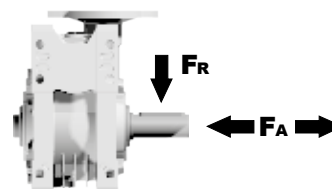

n ₂ [min ⁻¹]	FA [N]	FR [N]
25	700	3800
15	800	4000

Input shaft

albero in entrata

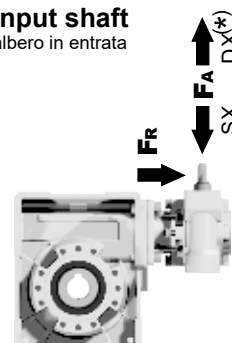

n ₁ [min ⁻¹]	FA [N]	FR [N]
1400	42	210

*Strong axial loads in the DX direction are not allowed.
Non sono consentiti forti carichi assiali con direzione DX

tab. 2

P64QFB... Basic wormbox
Riduttore base

Gearbox weight
peso riduttore **7.25 kg**

M. flanges	Kit code	øF	A
63B5	K050.4.041	138	74
71B5	K050.4.042	160	71.5
56B14	KC40.4.049	80	71.5
63B14	K050.4.047	90	74
71B14	K050.4.045	105	71.5

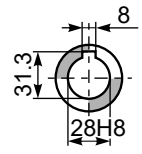
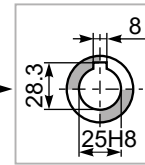
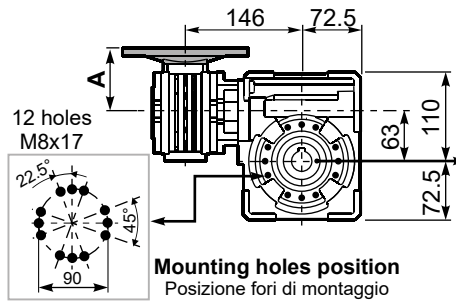
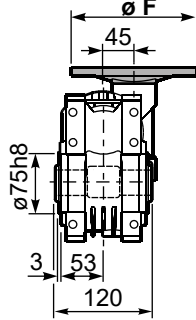

Mounting holes position
Posizione fori di montaggio

Standard
Hollow shaft

On Request
A richiesta

P64QFC... Square flange
Flangia quadrata

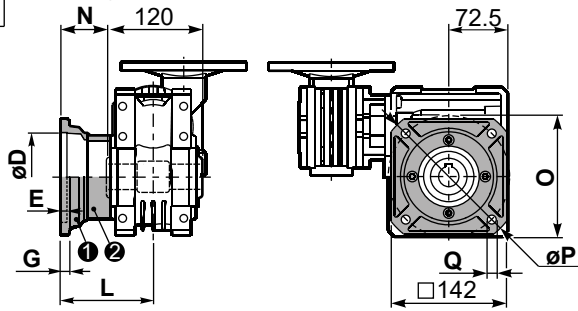

P64QF1... Round flange
Flangia rotonda

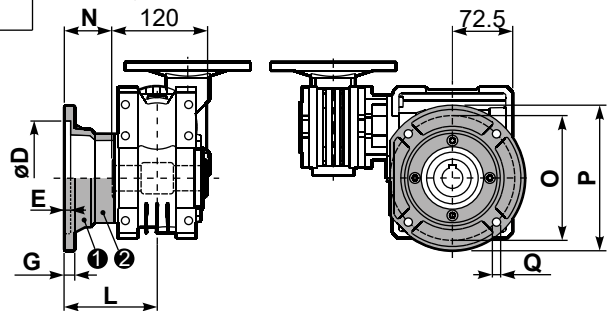

type B	øD	E	G	L	N	O	P	Q	kit code
FC	115 ^{+0.20} / _{+0.15}	6	12	86	26	150	180	11	① KQ63.9.010 ② -
FL	115 ^{+0.20} / _{+0.15}	6	12	116	56	150	180	11	① KQ63.9.010 ② K063.0.200

type S	øD	E	G	L	N	O	P	Q	kit code
F1	130 ^{+0.20} / _{+0.15}	7	13	110	50	165	200	13	① KS070.9.013 ② -
F2	115 ^{+0.20} / _{+0.15}	7	13	124	64	150	175	11	① KS063.9.013 ② -
F3	110 ^{+0.035} / ₀	5	11	90	30	130	160	10	① KS063.9.011 ② -

P64QFB... Feet
Piedi

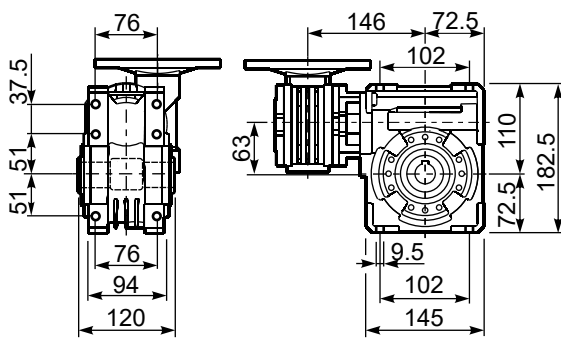

P64QBR... Reaction arm
Braccio di reazione

kit cod. K063.9.027

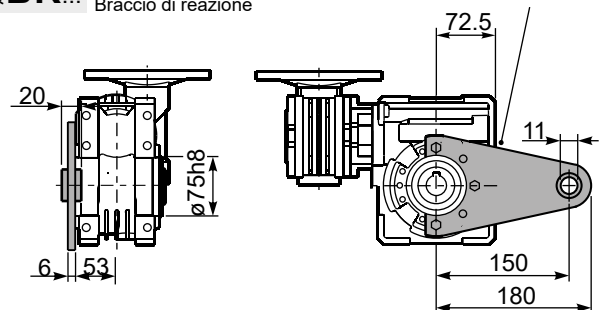

R64QFB... Input shaft
Albero in entrata

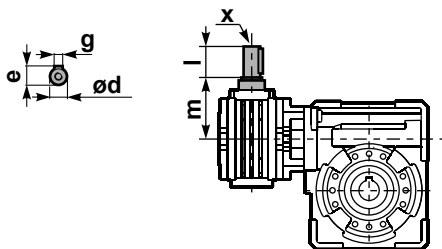

P64Q....S... Single Shaft
Albero lento semplice

P64Q....D... Double Shaft
Albero lento bisp.

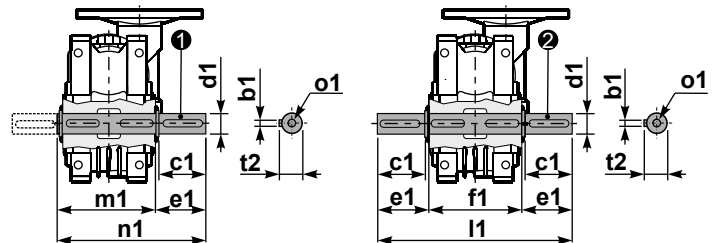

① kit cod. K063.5.028 type B

② kit cod. K063.5.029 type B

	ød	e	g	l	m	x	kit code
type B	11 h6	12.5	4	30	68	-	① K045.5.006 PAM71 ② -
type S	-	-	-	-	-	-	① - ② -

	b1	c1	d1	e1	f1	l1	m1	n1	t2	o1
type B	8	60	25 ^{-0.005} / _{-0.020}	63.2	120	246.4	126.8	190	28	M8x20
type S	-	-	-	-	-	-	-	-	-	-

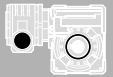

QUICK SELECTION / Selezione veloce

input speed (n_1) = 1400 min⁻¹

Output Speed n_2 [min ⁻¹]	Ratio i	Motor power P_{1M} [kW]	Output torque M_{2M} [Nm]	Service factor f.s.	Nominal power P_{1R} [kW]	Nominal torque M_{2R} [Nm]	Available B5 motor flanges		Available B14 motor flanges			Dynamic efficiency RD	Tooth Module [mm]	Ratios code
							-B	-C	-O	-P	-Q			
5	280	0.37	403	0.9	0.33	359	B		B-C	B-C		57	3.10	01
3.5	400	0.25	314	1.1	0.29	359	B		B-C	B-C		46	3.10	02
2.5	560	0.25	420	0.9	0.21	359	B		B-C	B-C		44	3.10	03
1.7	840	0.18	423	0.8	0.15	359	B		B-C	B-C		41	3.10	04
1.3	1120	0.12	339	1.1	0.13	359	B		B-C	B-C		37	3.10	05
0.9	1480	0.09	336	1.1	0.10	359	B		B-C	B-C		37	3.10	06
0.8	1840	0.09	373	1.0	0.09	359	B		B-C	B-C		33	3.10	07
0.6	2400	0.06	275	1.3	0.08	359	B		B-C	B-C		28	3.10	08
0.5	2800	0.06	298	1.2	0.07	359	B		B-C	B-C		26	3.10	09
0.3	4080	0.06	250	1.4	0.09	359	B		B-C	B-C		15	3.10	10

A Motor Flanges Available
Flange Motore Disponibili

B Supplied with Reduction Bushing
Fornito con Bussola di Riduzione

B Available on Request without reduction bushing
Disponibile a Richiesta senza Bussola di Riduzione

C Motor Flange Holes Position
Posizione Fori Flangia Motore

EN Unit 74Q is supplied with synthetic oil, providing "long life" lubrication. For mounting position V5-V6 please contact us. See table 1 for lubrication and recommended quantity. In table 2 please see possible radial loads and axial loads on the gearbox.

I Il riduttore tipo 74Q viene fornito lubrificato a vita con olio sintetico. Per posizioni V5-V6 contattare il ns. servizio tecnico. Vedi tab.1 per oli e quantità consigliati. In tab.2 sono presenti i carichi radiali e assiali applicabili al riduttore.

D Für die Lebensdauerschmierung ist das Getriebe der Größe 74Q mit synthetischem Öl befüllt. Bei Einbaulage V5 oder V6 bitten wir um Rücksprache. In Tabelle 1 ist die Schmiermenge und das empfohlene Schmiermittel angegeben. In Tabelle 2 sind die zulässigen Radial- und Axialbelastungen des Getriebes aufgeführt.

F Le réducteur de type 74Q est fourni lubrifié à vie avec de l'huile synthétique. Concernant les positions V5.V6, contactez notre service d'assistance technique. Voir tableau 1 concernant les huiles et les quantités conseillées. Les charges radiales et axiales applicables au réducteur sont précisées dans le tableau 2.

E El reductor tamaño 74Q se suministra, lubricado de por vida con aceite sintético. Para las posiciones V5 y V6 contactar con nuestro servicio técnico. Ver tabla 1, para cantidades y aceites recomendados. En la tabla 2, se encuentran las cargas radiales y axiales admitidas por el reductor.

LUBRICATION 74Q Oil
Quantity 0.40/0.09 Lt.

0.40 Lt. 0.09 Lt.

SHELL Omala S4 WE 320

ENI Telium VSF 320

For all details on lubrication and plugs check our website **tab. 1**
Per maggiori dettagli su lubrificazione e tappi olio vedi il nostro sito web

RADIAL AND AXIAL LOADS

Output shaft
Albero di uscita

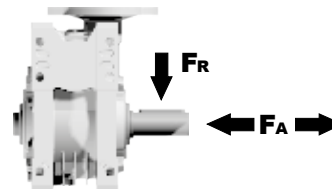

n_2 [min ⁻¹]	FA [N]	FR [N]
25	880	4400
15	1000	5000

Input shaft
albero in entrata

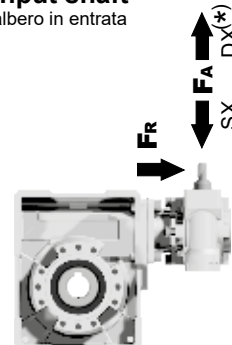

n_1 [min ⁻¹]	FA [N]	FR [N]
1400	42	210

*Strong axial loads in the DX direction are not allowed.
Non sono consentiti forti carichi assiali con direzione DX

tab. 2

P74QFB... Basic wormbox
Riduttore base

Gearbox weight
peso riduttore **11.4 kg**

M. flanges	Kit code	øF	A
63B5	K050.4.041	138	74
71B5	K050.4.042	160	71.5
56B14	KC40.4.049	80	71.5
63B14	K050.4.047	90	74
71B14	K050.4.045	105	71.5

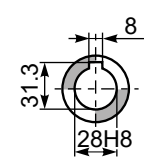
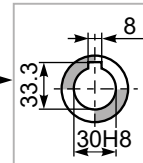
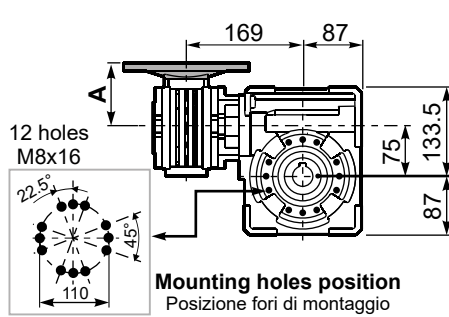
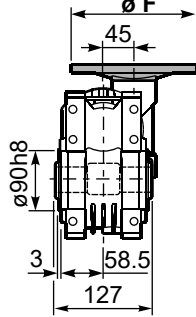

Mounting holes position
Posizione fori di montaggio

Standard
Hollow shaft

On request
A richiesta

P74QFC... Square flange
Flangia quadrata

P74QFL... Square flange
Flangia quadrata

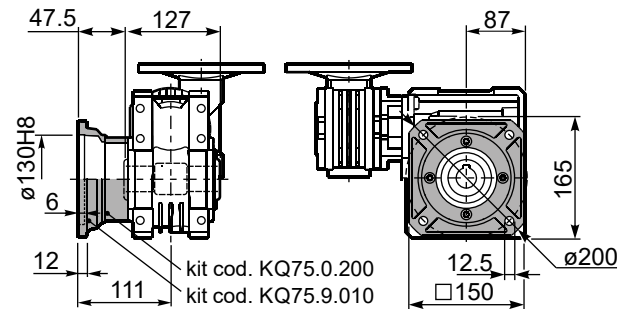
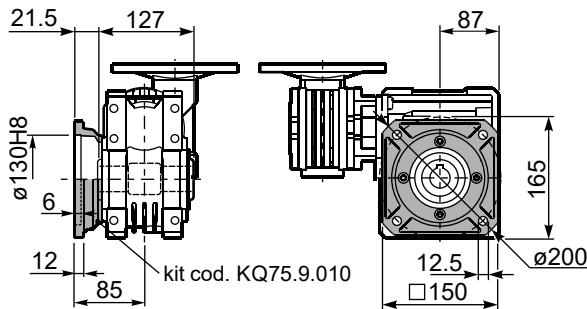

P74QFB... Feet
Piedini

P74QBR... Reaction arm
Braccio di reazione

kit cod. KQ75.9.027

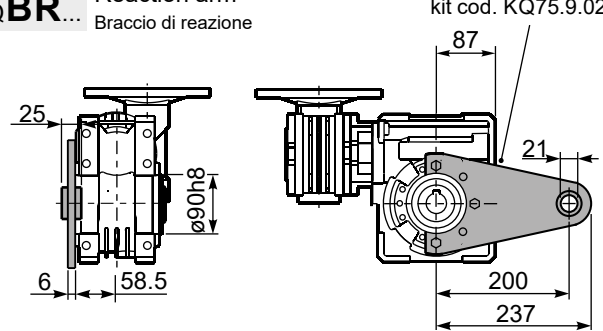
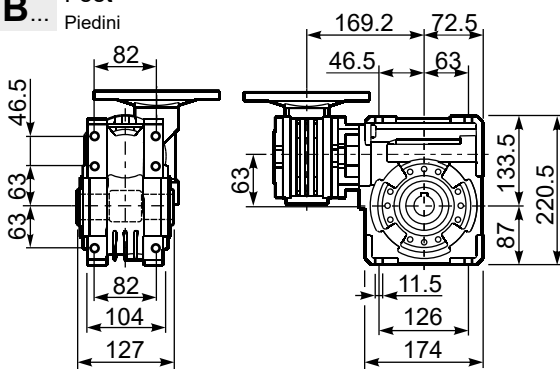

R74QFB... Input shaft
Albero in entrata

P74Q.....S... Single Shaft
Albero lento semplice

P74Q.....D... Double Shaft
Albero lento bisp.

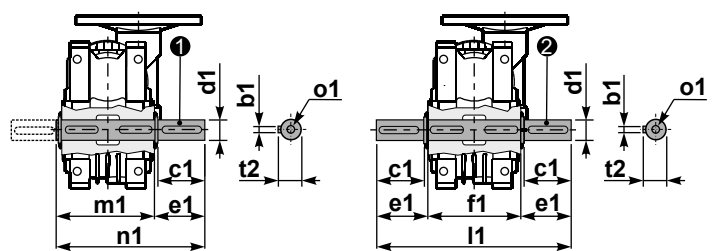
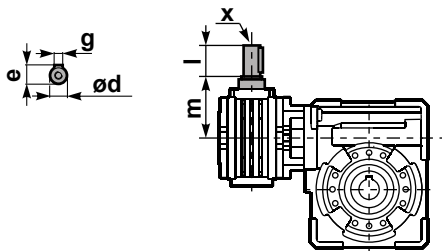

① kit cod. KQ75.5.028 Standard ② kit cod. KQ75.5.029 Standard
kit cod. KQ75.5.026 On request

	ød	e	g	l	m	x	kit code
type B	11 h6	12.5	4	30	68	-	① K045.5.006 PAM71 ② -
type S	-	-	-	-	-	-	① - ② -

	b1	c1	d1	e1	f1	l1	m1	n1	t2	o1
Standard	8	60	30 ^{-0.005} _{-0.020}	65	127	255	134	199	33	M8x20
On request	8	60	28 ^{-0.005} _{-0.020}	65	-	-	134	199	31	M8x20

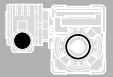

QUICK SELECTION / Selezione veloce

input speed (n_1) = 1400 min⁻¹

Output Speed n_2 [min ⁻¹]	Ratio i	Motor power P_{1M} [kW]	Output torque M_{2M} [Nm]	Service factor f.s.	Nominal power P_{1R} [kW]	Nominal torque M_{2R} [Nm]	Available B5 motor flanges		Available B14 motor flanges			Dynamic efficiency RD	Tooth Module [mm]	Ratios code
							-B	-C	-O	-P	-Q			
							63	71	56	63	71			
10	140	0.37	205	1.8	0.66	368	B		B-C	B-C		58	4.5	01
7.1	196	0.37	257	1.4	0.53	368	B		B-C	B-C		52	4.7	02
5.0	280	0.37	332	1.6	0.58	518	B		B-C	B-C		47	4.7	03
3.6	392	0.37	435	1.2	0.44	518	B		B-C	B-C		44	4.7	04
2.4	588	0.25	371	1.4	0.35	518	B		B-C	B-C		37	4.7	05
1.8	784	0.25	455	1.1	0.28	518	B		B-C	B-C		34	4.7	06
1.4	1036	0.18	420	1.2	0.22	518	B		B-C	B-C		33	4.7	07
1.1	1288	0.18	474	1.1	0.20	518	B		B-C	B-C		30	4.7	08
0.7	1960	0.12	449	1.2	0.14	518	B		B-C	B-C		28	4.7	09
0.5	2856	0.12	584	0.9	0.11	518	B		B-C	B-C		25	4.7	10

Motor Flanges Available
Flange Motore Disponibili

B) Supplied with Reduction Bushing
Fornito con Bussola di Riduzione

Available on Request without reduction bushing
Disponibile a Richiesta senza Bussola di Riduzione

C) Motor Flange Holes Position
Posizione Fori Flangia Motore

EN Unit **84Q** is supplied with synthetic oil, providing "long life" lubrication. For mounting position V5-V6 please contact us. See table 1 for lubrication and recommended quantity. In table 2 please see possible radial loads and axial loads on the gearbox.

I Il riduttore tipo **84Q** viene fornito lubrificato a vita con olio sintetico. Per posizioni V5-V6 contattare il ns. servizio tecnico. Vedi tab.1 per oli e quantità consigliati. In tab.2 sono presenti i carichi radiali e assiali applicabili al riduttore.

D Für die Lebensdauerschmierung ist das Getriebe der Größe **84Q** mit synthetischem Öl befüllt. Bei Einbaulage V5 oder V6 bitten wir um Rücksprache. In Tabelle 1 ist die Schmiermenge und das empfohlene Schmiermittel angegeben. In Tabelle 2 sind die zulässigen Radial- und Axialbelastungen des Getriebes aufgeführt.

F Le réducteur de type **84Q** est fourni lubrifié à vie avec de l'huile synthétique. Concernant les positions V5.V6, contactez notre service d'assistance technique. Voir tableau 1 concernant les huiles et les quantités conseillées. Les charges radiales et axiales applicables au réducteur sont précisées dans le tableau 2.

E El reductor tamaño **84Q** se suministra, lubricado de por vida con aceite sintético. Para las posiciones V5 y V6 contactar con nuestro servicio técnico. Ver tabla 1, para cantidades y aceites recomendados. En la tabla 2, se encuentran las cargas radiales y axiales admitidas por el reductor.

LUBRICATION 84Q Oil
Quantity 1.20/0.09 Lt.

SHELL Omala S4 WE 320 **ENI** Telium VSF 320

For all details on lubrication and plugs check our website **tab. 1**
Per maggiori dettagli su lubrificazione e tappi olio vedi il nostro sito web

RADIAL AND AXIAL LOADS

Output shaft

Albero di uscita

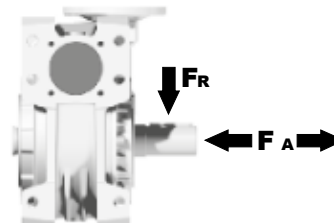

n [min ⁻¹]	FA [N]	FR [N]
25	1000	5000
15	1160	5800

Input shaft

albero in entrata

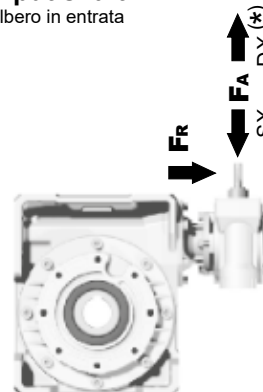

n [min ⁻¹]	FA [N]	FR [N]
1400	42	210

***Strong axial loads in the DX direction are not allowed.**
Non sono consentiti forti carichi assiali con direzione DX

tab. 2

P84QFB... Basic wormbox
Riduttore base

Gearbox weight
peso riduttore **16.2 kg**

M. flanges	Kit code	øF	A
63B5	K050.4.041	138	74
71B5	K050.4.042	160	71.5
56B14	KC40.4.049	80	71.5
63B14	K050.4.047	90	74
71B14	K050.4.045	105	71.5

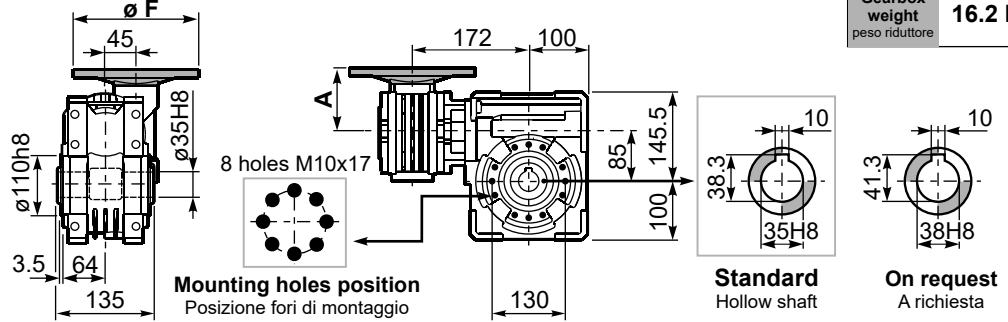

P84QFC... Output flange
Flangia uscita

P84QF1... Output flange
Flangia uscita

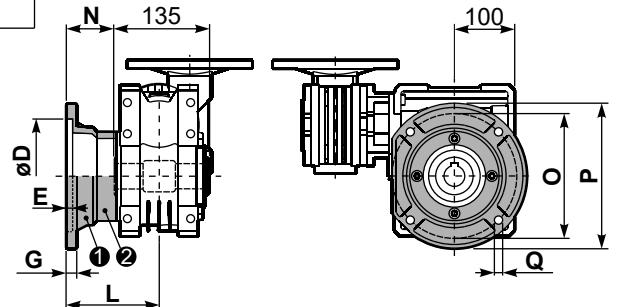
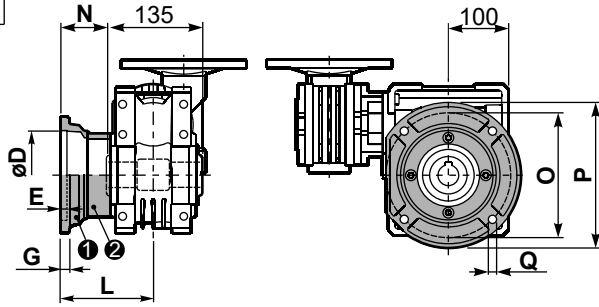

type B	øD	E	G	L	N	O	P	Q	kit code
FC	152 ^{+0.06} / _{+0.00}	5	16	108	40.5	176	205	13	① K085.9.010 ② -
FL	152 ^{+0.06} / _{+0.00}	5	16	148.5	81	176	205	13	① K085.9.010 ② K085.0.201

type S	øD	E	G	L	N	O	P	Q	kit code
F1	130 H7	5	13	117.5	50	165	200	11.5	① KS085.9.012 ② -
F2	152 ^{+0.06} / _{+0.00}	5	15	147.5	80	180	205	12.5	① KS085.9.013 ② -
F4	130 H7	5	13	106.5	39	165	200	13	① KS085.9.015 ② -

P84QFB... Feet
Piedini

P84QBR... Reaction arm
Braccio di reazione

kit cod. K085.9.027

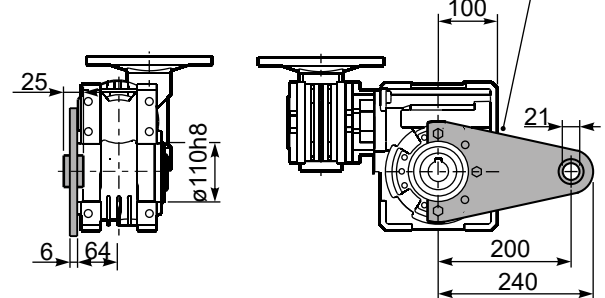
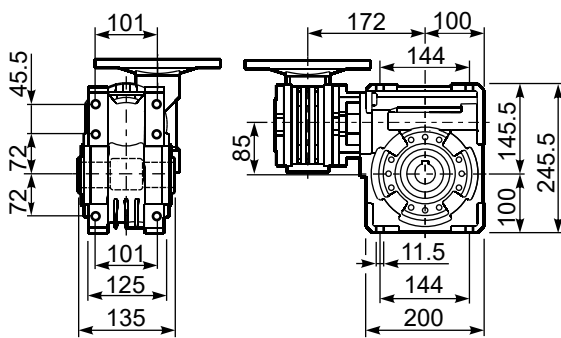

R84QFB... Input shaft
Albero in entrata

P84Q.....S... Single Shaft
Albero lento semplice

P84Q.....D... Double Shaft
Albero lento bisp.

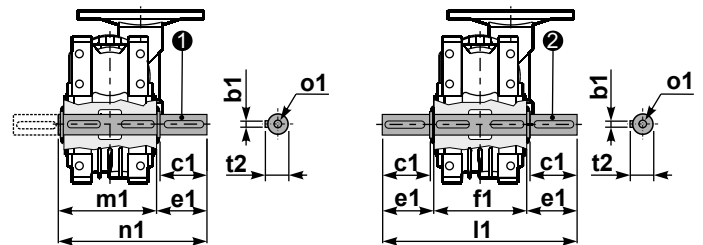
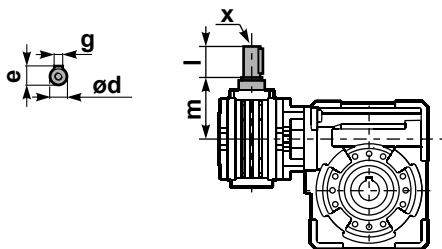

① kit cod. K085.5.028 type B ② kit cod. K085.5.029 type B

	ød	e	g	l	m	x	kit code
type B	11 h6	12.5	4	30	68	-	① K045.5.006 PAM71 ② -
type S	-	-	-	-	-	-	① - ② -

	b1	c1	d1	e1	f1	l1	m1	n1	t2	o1
type B	10	60	35 ^{-0.005} / _{-0.020}	73.5	135	282	141	214.5	38	M10x23
type S	-	-	-	-	-	-	-	-	-	-

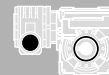

QUICK SELECTION / Selezione veloce

input speed (n_1) = 1400 min⁻¹

Output Speed n_2 [min ⁻¹]	Ratio i	Motor power P_{1M} [kW]	Output torque M_{2M} [Nm]	Service factor f.s.	Nominal power P_{1R} [kW]	Nominal torque M_{2R} [Nm]	Available B5 motor flanges			Available B14 motor flanges				Dynamic efficiency RD	Tooth Module [mm]	Ratios code
							-B	-C	-D	-O	-P	-Q	-R			
							63	71	80	56	63	71	80			
6.7	210	0.75	591	1.5	1.1	863	B	B			B-C	B		55	5.6	01
4.7	300	0.75	752	1.3	0.97	978	B	B			B-C	B		49	5.6	02
3.3	420	0.55	741	1.3	0.73	978	B	B			B-C	B		47	5.6	03
2.6	540	0.55	851	1.1	0.63	978	B	B			B-C	B		42	5.6	04
1.8	780	0.37	748	1.3	0.48	978	B	B			B-C	B		38	5.6	05
1.3	1080	0.37	1009	1.0	0.36	978	B			B-C	B-C			37	5.6	06
1.1	1290	0.25	770	1.3	0.32	978	B			B-C	B-C			35	5.6	07
0.8	1800	0.25	921	1.1	0.27	978	B			B-C	B-C			30	5.6	08
0.7	2040	0.18	751	1.3	0.23	978	B			B-C	B-C			30	5.6	09
0.6	2400	0.18	825	1.2	0.21	978	B			B-C	B-C			28	5.6	10
0.5	3000	0.18	958	1.0	0.18	978	B			B-C	B-C			26	5.6	11

Motor Flanges Available
Flange Motore Disponibili

B) Supplied with Reduction Bushing
Fornito con Bussola di Riduzione

B) Available on Request without reduction bushing
Disponibile a Richiesta senza Bussola di Riduzione



C) Motor Flange Holes Position
Posizione Fori Flangia Motore

EN Unit **15Q** is supplied without lubricant and equipped with a breather, level and drain plugs. User can add mineral oil keeping existing plugs. Should the user wish to fill it with synthetic oil, it is recommended to replace the existing plugs with a type that are closed. Gearbox **050** is supplied lubricated for life. See tab.1 for oils and recommended quantity. In tab.2 there are radial loads and axial loads applicable to the gearbox.

I Il riduttore tipo **15Q** è fornito privo di lubrificazione con tappi di sfiato, livello e scarico olio. L'utente può immettere olio minerale mantenendo i tappi esistenti. Se immetterà olio sintetico, dovrà sostituire i tappi esistenti con altri tipo chiuso. Il riduttore **050** è fornito lubrificato a vita con olio sintetico. Tab.1 per oli e quantità consigliati. Tab.2 carichi radiali e assiali applicabili al riduttore.

D Das Getriebe der Baugröße **15Q** wird ohne Schmiermittel geliefert. Es ist jedoch mit Einfüllschraube, Überdruckventil und Ablassschraube ausgerüstet. Das benötigte mineralische Öl kann über die Einfüllschraube eingefüllt werden. Sollte synthetisches Öl bevorzugt werden, so ist sind das eingebaute Überdruckventil durch eine geschlossenen Schraube zu ersetzen. Das Getriebe der Baugröße **050** ist lebensdauer geschmiert. In Tabelle 1 ist die Schmiermenge und das empfohlene Schmiermittel angegeben. In Tabelle 2 sind die zulässigen Radial - und Axialbelastungen des Getriebes aufgeführt.

F Le réducteur de type **15Q** est fourni sans lubrification et avec un bouchon de remplissage, de niveau et d'évacuation de l'huile. L'utilisateur peut y verser de l'huile minérale en conservant les bouchons existants. S'il y versera de l'huile synthétique, il devra substituer les bouchons existants avec d'autres bouchons de type fermé. Le réducteur de type **050** est fourni lubrifié à vie avec de l'huile synthétique. Voir tableau 1 concernant les huiles et les quantités conseillées. Voir tableau 2 concernant les charges radiales et axiales applicables au réducteur.

E El reductor tamaño **15Q** se suministra sin lubricante, provisto de tapones de respiración, nivel y descarga de aceite. El usuario puede utilizar aceite mineral, manteniendo los tapones existentes. Si prefiera utilizar aceite sintético deberá sustituir los tapones existentes por tapones ciegos. El reductor **050** se suministra lubricado de por vida con aceite sintético. Ver tabla 1, para cantidades y aceites recomendados. En la tabla 2, se encuentran las cargas radiales y axiales admitidas por el reductor.

B3	B6	B7	B8	V5	V6
1.9/0.14LT	1.35/0.14 LT	1.35/0.14 LT	2.0/0.14 LT	2.0/0.14 LT	2.0/0.14 LT
SHELL Omala S2 GX 460			ENI Blasias 460		

For all details on lubrication and plugs check our website **tab. 1**
Per maggiori dettagli su lubrificazione e tappi olio vedi il nostro sito web

RADIAL AND AXIAL LOADS

Output shaft
Albero di uscita

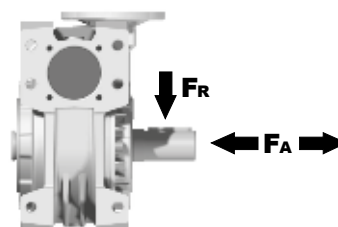

n_2 [min ⁻¹]	FA [N]	FR [N]
25	1200	6000
15	1400	7000

Input shaft
albero in entrata

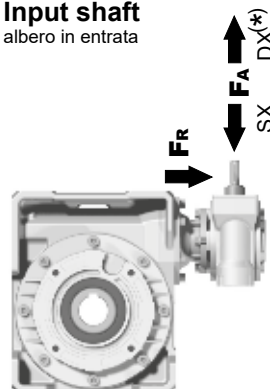

n_1 [min ⁻¹]	FA [N]	FR [N]
1400	76	380

***Strong axial loads in the DX direction are not allowed.**
Non sono consentiti forti carichi assiali con direzione DX

tab. 2

P15QFB... Basic wormbox
Riduttore base

Gearbox weight
peso riduttore **38.8 kg**

M. flanges	Kit code	øF	A
63B5	K050.4.041	138	78.5
71B5	K050.4.042	160	76
80B5	K050.4.043	200	76.5
56B14	KC40.4.049	80	76
63B14	K050.4.047	90	78.5
71B14	K050.4.045	105	76
80B14	K050.4.046	120	76.5

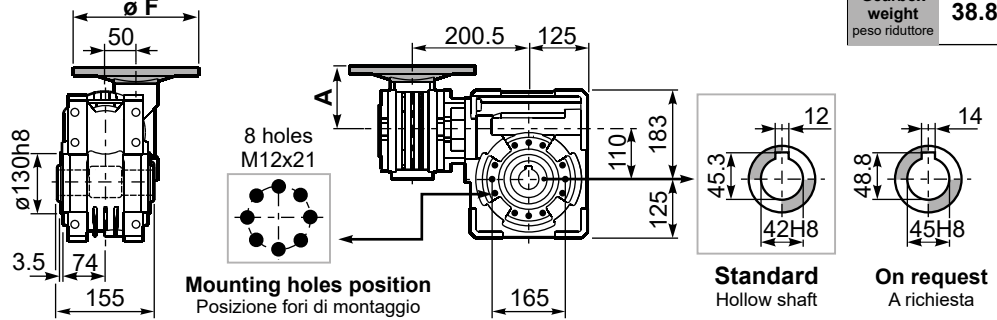

Mounting holes position
Posizione fori di montaggio

Standard
Hollow shaft

On request
A richiesta

P15QFC... Output flange
Flangia uscita

P15QF1... Output flange
Flangia uscita

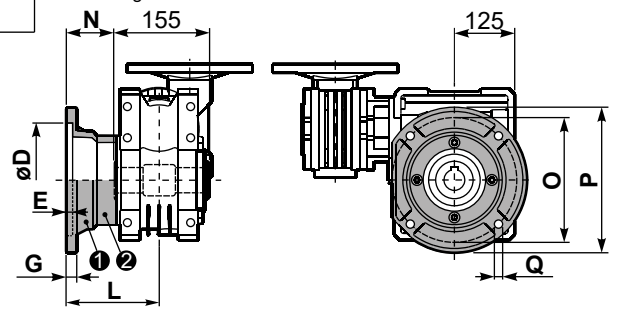
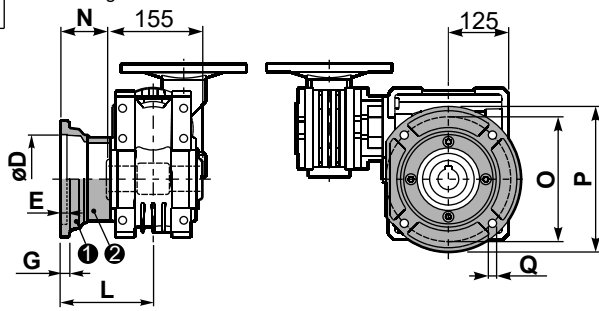

type B	øD	E	G	L	N	O	P	Q	kit code
FC	170 ^{+0.083} _{+0.043}	11	16.5	131.5	54	230	270	13	① K110.9.010 ② -
FL	170 ^{+0.083} _{+0.043}	11	16.5	179.5	102	230	270	13	① K110.9.011 ② -

type S	øD	E	G	L	N	O	P	Q	kit code
F1	180 ^{+0.040} ₀	5	18	150	72.5	215	250	15	① KS110.9.014 ② -
F3	180 ^{+0.040} ₀	5	18	130	52.5	215	250	15	① KS110.9.013 ② -

P15QFB... Feet
Piedini

P15QBR... Reaction arm
Braccio di reazione

kit cod. K110.9.027

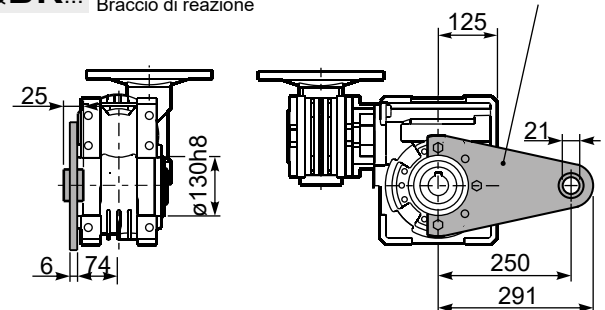
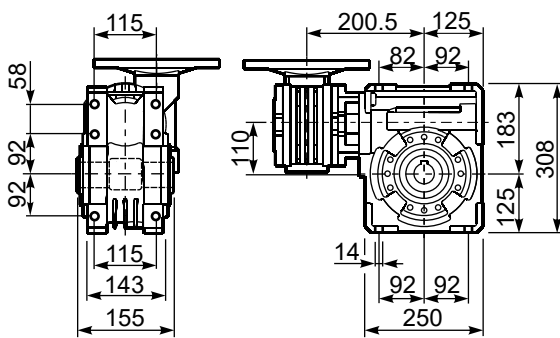

R15QFB... Input shaft
Albero in entrata

P15Q.....S... Single Shaft
Albero lento semplice

P15Q.....D... Double Shaft
Albero lento bisp.

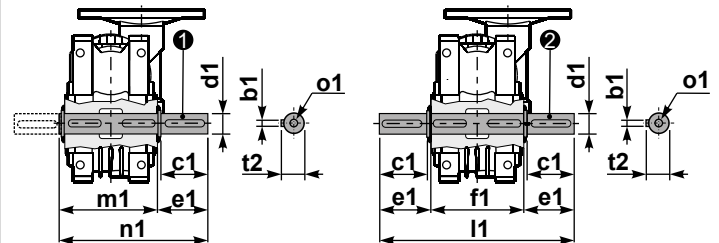
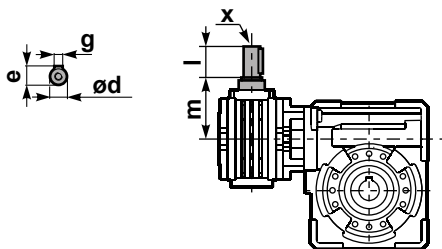

① kit cod. K110.5.028 type B

② kit cod. K110.5.029 type B

	ød	e	g	l	m	x	kit code
type B	16 h6	18	5	30	79.5	M6x16	① K050.5.006 PAM71 ② K050.5.007 PAM80
type S	14 h6	16	5	30	79.5	M5x10	① KS050.5.008 PAM71 ② KS050.5.009 PAM80

	b1	c1	d1	e1	f1	l1	m1	n1	t2	o1
type B	12	75	42 ^{-0.005} _{-0.020}	96.5	155	348	163.5	260	45	M12x32
type S	-	-	-	-	-	-	-	-	-	-

Aluminum one step gearboxes

A modular and compact product

4

Alloy housing

Is vacuum impregnated (MIL-STD 276) for protection and sealing. No secondary finish required but readily accepts paint

Flange

Fully modular to IEC and Compact integrated motor. NEMA C flange

Gears

Hardened and ground gears.

Removable inspection cover

Allows periodic inspection of gearing during routine maintenance

Output shaft

With well proportioned bearings

Feet

Removable feet.

Single-piece aluminum alloy housing

Combines light weight with high tensile strength. Precision machined for alignment of bearings and gearing

Ideal for use as first step with wormgearboxes.

Lubricated for life with synthetic oil with operative range from -15° to +130°C

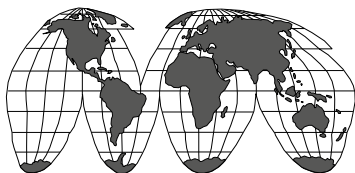

World wide sales network.



Specific type datasheet on page...

On page / A pagina / Auf Seite / À la page / En la página



Types / Tipi
Tipen / Types
Tipos



4-5	4-7	4-9	4-11
211A 20Nm	311A 30Nm	411A 38Nm	511A 110Nm

On page / A pagina / Auf Seite / À la page / En la página

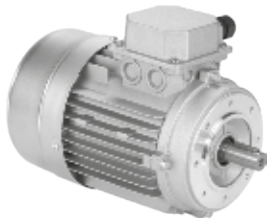

Types / Tipi
Tipen / Types
Tipos



M-1									
56A 56B	63A 63B	71A 71B	80A 80B	90S 90L	100LA 100LB	112M	132S 132M	160M 160L	180M 180L

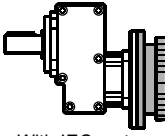
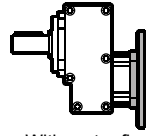
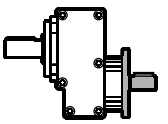
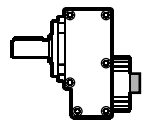
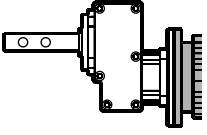
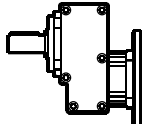
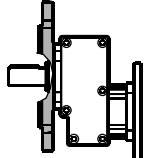
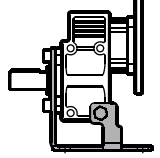





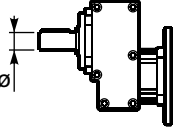
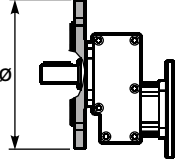

Type - Tipo - Typ Type - Tipo	Size - Grandezza - Grösse Taille - Tamaño	Mounting - Montaggio Montage - Fixation Tipo de montaje	Ratio - Rapporto Untersetzung Reduction Relación
P	311A	-F	2.84
<p>Aluminum one step gear Riduttori in alluminio a uno stadio</p> <div style="display: flex; justify-content: space-around;"> <div style="text-align: center;">  With IEC motor M </div> <div style="text-align: center;">  With motor flange P </div> </div> <div style="display: flex; justify-content: space-around; margin-top: 20px;"> <div style="text-align: center;">  With male input shaft R </div> <div style="text-align: center;">  Modular Base B </div> </div> <div style="border: 1px solid black; padding: 10px; margin-top: 20px; text-align: center;"> <p>Special output shaft Albero uscita speciale</p>  <p>Only on request for Q.ty A richiesta per quantità</p> </div>	<p>1 Stages Riduzioni Stufen Trains Etapas</p> <div style="border: 1px solid black; padding: 5px; margin: 10px auto; width: 80px; text-align: center;"> <p>211A 311A 411A 511A</p> </div>	 Without flange / feet -N  Output flange mounted -F  Mounted feet H1	<p>See technical data table</p> <p>Vedi tabelle dati tecnici.</p> <p>Technisches Datenblatt beachten</p> <p>Voir Tableau données techniques</p> <p>Ver tabla datos técnicos</p>

4

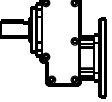
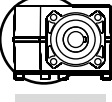
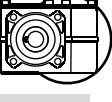
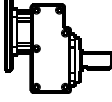
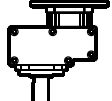
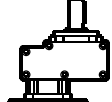
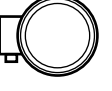

On request we can deliver our products according to the ATEX
 A richiesta possiamo fornire i nostri prodotti secondo le normative ATEX
 Auf Anfrage können wir unsere Produkte den Richtlinien ATEX entsprechend liefern
 Sur demande nos produits peuvent se conformer à la réglementation ATEX
 A pedido, se pueden enviar nuestros productos de acuerdo con las normas ATEX.

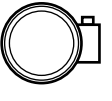
CODIFICA / HOW TO ORDER / TYPENBEZEICHNUNGEN / CODIFICATION / CODIFICACIÓN

Output shaft Albero uscita Abtriebswelle Arbre de sortie Eje en salida	Output flange Flangia uscita Ausgangsflansch Bride de sortie Brida en salida	Motor size - Grandezza motore Motor Größe Motor Grösse Grandeur moteur - Tamaño motor	Mounting position Posizione montaggio Einbaulage Position de montage Position de montaje	Input bore Foro entrata Eingangshohlwelle Trou d'entree Eje hueco de entrada	Terminal box position Posizione morsettieria Klemmkastenlage Position boîte à bornes Posición caja de bornes
<p align="center">S</p>  <p>→ STANDARD</p> <p>211A</p> <p>S → ∅14</p> <p>311A</p> <p>S → ∅14</p> <p>C ⇒ ∅19</p> <p>E ⇒ ∅24</p> <p>411A</p> <p>S ⇒ ∅14</p> <p>C ⇒ ∅19</p> <p>E ⇒ ∅24</p> <p>G ⇒ ∅28</p> <p>511A</p> <p>C ⇒ ∅19</p> <p>E ⇒ ∅24</p> <p>G ⇒ ∅28</p>	<p align="center">2</p>  <p>N Senza flangia Without flange</p> <p>211A</p> <p>I ⇒ ∅105 Flangia integrata Integrated flange</p> <p>311A</p> <p>1 ⇒ ∅120</p> <p>2 ⇒ ∅140</p> <p>3 ⇒ ∅160</p> <p>4 ⇒ ∅200</p> <p>411A</p> <p>1 ⇒ ∅120</p> <p>2 ⇒ ∅140</p> <p>3 ⇒ ∅160</p> <p>4 ⇒ ∅200</p> <p>5 ⇒ ∅250</p> <p>511A</p> <p>1 ⇒ ∅120</p> <p>2 ⇒ ∅140</p> <p>3 ⇒ ∅160</p> <p>4 ⇒ ∅200</p> <p>5 ⇒ ∅250</p>	<p align="center">-C</p> <p>Flange Flangia</p>  <p>B5</p> <p>-A=56 (∅120)</p> <p>-B=63 (∅140)</p> <p>-C=71 (∅160)</p> <p>-D=80 (∅200)</p> <p>-E=90 (∅200)</p> <p>-F=100+112 (∅250)</p> <p>-G=132 (∅300)</p> <p>B14</p> <p>-O=56 (∅80)</p> <p>-P=63 (∅90)</p> <p>-Q=71 (∅105)</p> <p>-R=80 (∅120)</p> <p>-T=90 (∅140)</p> <p>-U=100+112 (∅160)</p> <p>-V=132 (∅200)</p> <p>Type R Tipo R</p>  <p>211A 311A</p> <p>-1 ⇒ ∅14</p> <p>411A</p> <p>-2 ⇒ ∅19</p> <p>511A</p> <p>-3 ⇒ ∅24</p> <p>Without flange Senza flangia</p>  <p>211A 311A</p> <p>-Z ⇒ ∅9 (56B5)</p> <p>-0 ⇒ ∅11 (63B5)</p> <p>-1 ⇒ ∅14 (71B5)</p> <p>411A</p> <p>-1 ⇒ ∅14 (71B5)</p> <p>-2 ⇒ ∅19 (80B5)</p> <p>-3 ⇒ ∅24 (90B5)</p> <p>511A</p> <p>-2 ⇒ ∅19 (80B5)</p> <p>-3 ⇒ ∅24 (90B5)</p> <p>-4 ⇒ ∅28 (100B5)</p>	<p align="center">B3</p>  <p>B3</p> <p>STANDARD</p>  <p>B6</p>  <p>B7</p>  <p>B8</p>  <p>V5</p>  <p>V6</p>	<p align="center">ST</p> <p>ST</p> <p>standard bore</p> <p>foro standard</p>	<p>With Type M specify terminal box position</p> <p>Con tipo M specificare posizione morsettieria</p>  <p>A</p>  <p>B</p> <p>STANDARD</p>  <p>C</p>  <p>D</p>

POTENZA RICHIESTA / REQUIRED POWER / ERFORDERLICHE LEISTUNG / PUISSANCE NECESSAIRE / POTENCIA NECESARIA

Lifting / sollevamento / hubantriebe / levage / elevación	$P [KW] = \frac{M [Kg] \cdot g [9.81] \cdot v [m / s]}{1000}$
Rotation / rotazione / drehung / rotation / rotação	$P [KW] = \frac{M [Nm] \cdot n [rpm]}{9550}$
Linear movement / traslazione / linearbewegung / translation / translación	$P [KW] = \frac{F [N] \cdot v [m / s]}{1000}$

TORQUE / COPPIA / DREHMOMENT / COUPLE / PAR

	$M [Nm] = \frac{9550 \cdot P[KW]}{n [rpm]}$
	$M [lb in] = \frac{63030 \cdot P[HP]}{n [rpm]}$

RADIAL LOADS / CARICHI RADIALI / RADIALE - UND AXIALLASTEN / CHARGES RADIALES / CARGA RADIAL Y AXIAL

- Radial load generated by external transmissions keyed onto input and/or output shafts.
- Forza radiale generata da organi di trasmissione calettati sugli alberi di ingresso e/o uscita.
- Belastungen der Antriebs- bzw. Abtriebswellen durch von aussen eingebrachte Radiallasten.
- Charge radiale générée par la transmissions calés sur les entrées et / ou des arbres de sortie
- Cargas radiales, generada por transmisiones externas, aplicadas sobre los ejes de entrada y/o salida

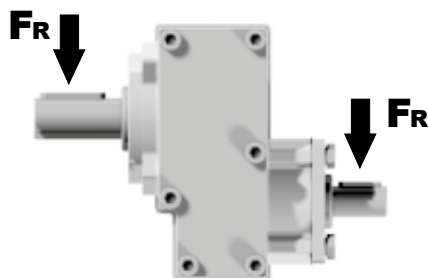

	$F_R [N] = \frac{M [Nm] \cdot 2000}{d [mm]} \cdot f_k$	$F_R [N] = \frac{M [lb in] \cdot 8.9}{d [in]} \cdot f_k$
M	Momento torcente / Output torque / Abtriebsdrehmoment / Couple / Par torsion	
d	Diametro primitivo / Diam. of driving element / Durchmesser der Abtriebseinheit / Diamètre primitif / Diámetro primitivo	
f_k	Coefficiente di trasformazione / Factor / Faktor / Coefficient de transmission / Coeficiente de transmisión 1.15 Ingranaggi / Gearwheels / Zahnrad / Engrenage / Engranaje 1.25 Catena / Chain sprockets / Antriebskette / Chaîne / Cadena 1.75 Cinghia Trapezoidale / Narrow v-belt pulley / Keilriemen / Courroie trap. / Correa trapezoidal 2.50 Cinghia piatta / Flat-belt pulley / Flachzahnriem. / Courroie crantée / Correa plana	

- If your application requires higher radial loads, contact our technical office. Higher load may be possible.
- Nel caso la vostra applicazione richieda carichi radiali superiori consultare il nostro ufficio tecnico, valori maggiori possono essere accettati.
- Wenn Ihre Anwendung höhere Radialbelastungen erfordert, so wenden Sie sich bitte an unser technischen Büro.
- Si votre application demande des charges radiales supérieures, s'adresser à notre bureau technique.
- En el caso en que una aplicación exija una carga radial superior a la especificada en el catálogo, consultar a nuestra oficinas técnica.

How to select a gearbox / Come selezionare un riduttore / Wie wählt man ein Getriebe
Comment sélectionner un réducteur / Cómo seleccionar un reductor

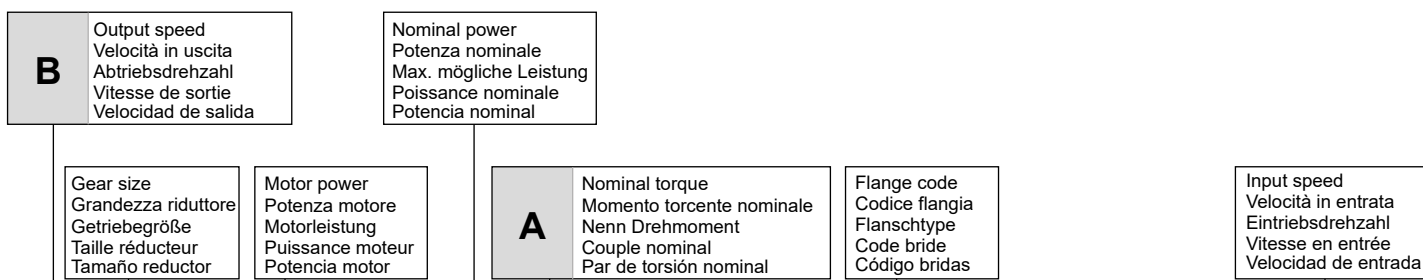

311A One step 30Nm

Rating - Aluminum ONE STEP GEARBOXES

QUICK SELECTION / Selezione veloce										input speed (n ₁) = 1400 min ⁻¹				
Output Speed n ₂ [min ⁻¹]	Ratio i	Motor power P _{1M} [kW]	Output torque M _{2M} [Nm]	Service factor f.s.	Nominal power P _{1R} [kW]	Nominal torque M _{2R} [Nm]	Available B5 motor flanges		Available B14 motor flanges			Output Shaft		
							-B	-C	-O	-P	-Q			Notes
892	1.57	0.37	3.9	3.3	1.24	13	63	71	C	C		2844	standard ø14	01
493	2.84	0.37	7.0	3.3	1.21	23			C	C		1954		02
426	3.29	0.37	8.1	3.2	1.18	26			C	C		1756		03
362	3.87	0.37	9.6	2.9	1.08	28			C	C		1558		04



fs		Oper. hours per day Ore di funz. giorn.		
Type of load and starts per hour Tipo di carico e avviamenti per ora		3 h	10 h	24 h
Continuous or intermittent appl. with start / hour Applicazione cont. o interm. con n.ro operazioni/ora	Uniform / Uniforme	0.8	1	1.25
	Moderate / Moderato	1	1.25	1.5
	Heavy / Forte	1.25	1.5	1.75
Intermittent application with start / hour Applicazione intermittente con n.ro operazioni/ora	Uniform / Uniforme	1	1.25	1.5
	Moderate / Moderato	1.25	1.5	1.75
	Heavy / Forte	1.5	1.75	2.15

D	Motor flange available Flange disponibili Erhältliche Motorflansche Brides disponibles Bridas disponibles	
B)	Mounting with reduction ring Montaggio con boccia di riduzione Reduzierhülsen Montage avec douille de réduction Montaje con casquillo de reducción	
C)	Motor flangeholes position/terminal box position Posizione fori flangia/basetta motore Bohrungsposition am Motorflansch/-sockel Position trous bride/barrette à bornes moteur Posición agujeros brida / base motor	
B)	Available without reduction bushes Disponibile anche senza boccia Auch ohne Reduzierbuchse verfügbar Disponible aussi sans douille de réduction Disponible tambien sin casquillo	

A	Select required torque (according to service factor)	Seleziona la coppia desiderata (comprensiva del fattore di servizio)	Max. Drehmoment in Bezug zum Betriebsfaktor	Sélectionner le couple souhaité (comprenant le facteur de service)	Seleccionar el par deseado (incluyendo el factor de servicio)
B	Select output speed	Seleziona la velocità in uscita	Ausgewählte Abtriebsdrehzahl	Sélectionner la vitesse de sortie	Seleccionar la velocidad de salida
C	On the same line of selected geared motor, you can find the gear ratio	Sulla riga corrispondente alla motorizzazione prescelta si può rilevare il rapporto di riduzione	Auf der gleichen Linie wie die ausgewählte Motorleistung steht auch die Getriebeuntersetzung	Sur la ligne correspondante à la motorisation pré-choisie on peut relever le rapport de réduction	En la línea correspondiente al motor preseleccionado es posible encontrar la relación de reducción
D	Select motor flange available (if requested)	Scegli la flangia disponibile (se richiesta)	Erhältliche Motorflansche (auf Anfrage)	Choisir la bride disponible (si elle est demandée)	Seleccionar la brida disponible (sobre pedido)



QUICK SELECTION / Selezione veloce

input speed (n₁) = 1400 min⁻¹

Output Speed n ₂ [min ⁻¹]	Ratio i	Motor power P _{1M} [kW]	Output torque M _{2M} [Nm]	Service factor f.s.	Nominal power P _{1R} [kW]	Nominal torque M _{2R} [Nm]	Available B5 motor flanges		Available B14 motor flanges			Output Shaft Ø	Ratios code
							-B	-C	-O	-P	-Q		
682	2.05	0.37	5	2.0	0.73	10			C	C		1939	01
595	2.35	0.37	6	2.1	0.76	12			C	C		1740	02
500	2.80	0.37	7	2.0	0.75	14			C	C		1542	03
414	3.38	0.37	8	2.0	0.75	17			C	C		1344	04
298	4.70	0.37	12	1.7	0.64	20			C	C		1047	05
225	6.22	0.37	15	1.5	0.55	23			C	C		956	06
169	8.29	0.37	20	1.0	0.36	20			C	C		758	07
142	9.83	0.25	16	1.0	0.24	16			C	C		659	08

The dynamic efficiency is **0.98** for all ratios

A Motor Flanges Available
Flange Motore Disponibili

B Supplied with Reduction Bushing
Fornito con Bussola di Riduzione

B Available on Request without reduction bushing
Disponibile a Richiesta senza Bussola di Riduzione

C Motor Flange Holes Position
Posizione Fori Flangia Motore

EN Unit **211A** is supplied with synthetic oil for lifetime lubrication, no maintenance is necessary. See table 1 for lubrication and recommended quantity. In table 2 please see possible radial loads and axial loads on the gearbox.

I Il riduttore **211A** viene fornito completo di olio sintetico per la lubrificazione permanente e non necessita di alcuna manutenzione. Vedi tab.1 per oli e quantità consigliati. In tab.2 sono presenti i carichi radiali e assiali applicabili al riduttore.

D Das Getriebe **211A** ist mit synthetischem Öl gefüllt und ist lebensdauergeschmiert. In Tabelle 1 ist die Schmiermenge und das empfohlene Schmiermittel angegeben. In Tabelle 2 sind die zulässigen Radial- und Axialbelastungen des Getriebes aufgeführt.

F Le réducteur **211A** est fourni complet avec de l'huile synthétique pour la lubrification permanente et ne nécessite aucun entretien. Voir tableau 1 concernant les huiles et les quantités conseillées. Les charges radiales et axiales applicables au réducteur sont précisées dans le tableau 2.

E El reductor tamaño **211A** se suministra, lubricado de por vida con aceite sintético y no requieren mantenimiento alguna. Ver tabla 1, para cantidades y aceites recomendados. En la tabla 2, se encuentran las cargas radiales y axiales admitidas por el reductor.

LUBRICATION 211A Oil Quantity 0.05 Lt.

SHELL Omala S4 WE 320

ENI Telium VSF 320

For all details on lubrication and plugs check our website **tab. 1**
Per maggiori dettagli su lubrificazione e tappi olio vedi il nostro sito web

RADIAL AND AXIAL LOADS

Output shaft

Albero di uscita

$$F_{eq} = F_R \cdot \frac{34.5}{X+19.5}$$

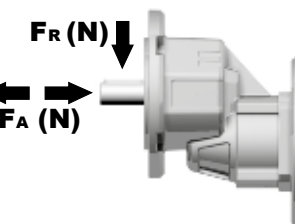
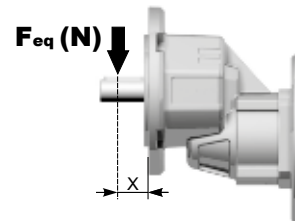

n ₂	FA	FR
700	101	504
600	120	600
400	138	696
300	151	756
200	175	876
140	192	960

Input shaft

albero in entrata

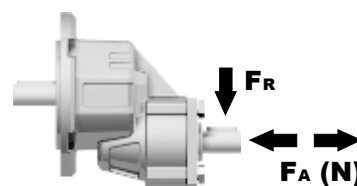

n ₁	FA	FR
1400	168	840
900	192	960

*Strong axial loads in the DX direction are not allowed.
Non sono consentiti forti carichi assiali con direzione DX

tab. 2

P211A-F... Basic wormbox
Riduttore base

Gearbox weight
peso riduttore **1.40 kg**

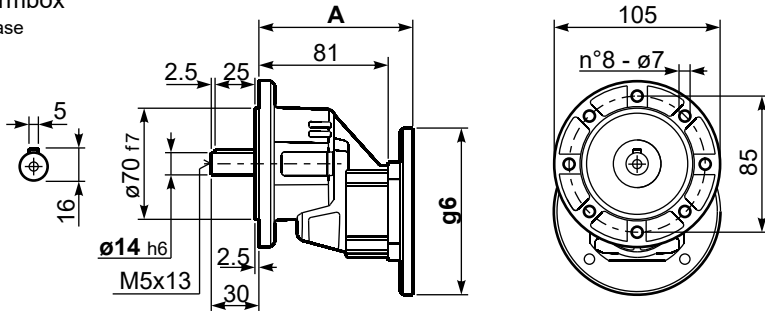

B5 Motor Flanges	A	g6	kit code
63 B5	99.5	138	K050.4.041
71 B5	97	160	K050.4.042

B14 Motor Flanges	A	g6	kit code
56 B14	97	80	KC40.4.049
63 B14	99.5	90	K050.4.047
71 B14	97	105	K050.4.045

R211A-F... Basic wormbox
Riduttore base

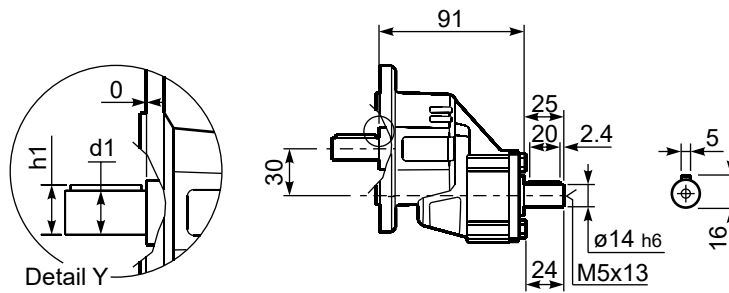

*Available output shaft / Albero di uscita

	Shaft - d1	p1	h1	x
Standard	$\varnothing 14 \times 30$	5	16	M5x13



QUICK SELECTION / Selezione veloce

input speed (n_1) = 1400 min⁻¹

Output Speed n_2 [min ⁻¹]	Ratio i	Motor power P_{1M} [kW]	Output torque M_{2M} [Nm]	Service factor f.s.	Nominal power P_{1R} [kW]	Nominal torque M_{2R} [Nm]	Available B5 motor flanges		Available B14 motor flanges			Output Shaft 	Ratios code		
							-B	-C	-O	-P	-Q				
891	1.57	0.37	4	3.3	1.2	13			C	C		2844	standard ø14	01	
493	2.84	0.37	7	3.3	1.2	23			C	C		1954		02	
425	3.29	0.37	8	3.2	1.2	26			C	C		1756		03	
362	3.87	0.37	10	2.9	1.1	28			C	C		1558		04	
303	4.62	0.37	11	2.6	0.97	30			C	C		1360		On request	05
222	6.30	0.37	16	2.2	0.83	35			C	C		1063		ø19	06
170	8.22	0.37	20	1.9	0.69	38			C	C		974		ø24	07
129	10.86	0.37	27	1.0	0.39	28			C	C		776			08

The dynamic efficiency is **0.98** for all ratios

A Motor Flanges Available
Flange Motore Disponibili

B Supplied with Reduction Bushing
Fornito con Bussola di Riduzione

B Available on Request without reduction bushing
Disponibile a Richiesta senza Bussola di Riduzione

C Motor Flange Holes Position
Posizione Fori Flangia Motore

4

EN Unit **311A** is supplied with synthetic oil for lifetime lubrication, no maintenance is necessary. See table 1 for lubrication and recommended quantity. In table 2 please see possible radial loads and axial loads on the gearbox.

I Il riduttore **311A** viene fornito completo di olio sintetico per la lubrificazione permanente e non necessita di alcuna manutenzione. Vedi tab.1 per oli e quantità consigliati. In tab.2 sono presenti i carichi radiali e assiali applicabili al riduttore.

D Das Getriebe **311A** ist mit synthetischem Öl gefüllt und ist lebensdauergeschmiert. In Tabelle 1 ist die Schmiermenge und das empfohlene Schmiermittel angegeben. In Tabelle 2 sind die zulässigen Radial- und Axialbelastungen des Getriebes aufgeführt.

F Le réducteur **311A** est fourni complet avec de l'huile synthétique pour la lubrification permanente et ne nécessite aucun entretien. Voir tableau 1 concernant les huiles et les quantités conseillées. Les charges radiales et axiales applicables au réducteur sont précisées dans le tableau 2.

E El reductor tamaño **311A** se suministra, lubricado de por vida con aceite sintético y no requieren mantenimiento alguna. Ver tabla 1, para cantidades y aceites recomendados. En la tabla 2, se encuentran las cargas radiales y axiales admitidas por el reductor.

LUBRICATION 311A Oil Quantity 0.10 Lt.

SHELL Omala S4 WE 320

ENI Telium VSF 320

For all details on lubrication and plugs check our website

tab. 1

Per maggiori dettagli su lubrificazione e tappi olio vedi il nostro sito web

RADIAL AND AXIAL LOADS

Output shaft

Albero di uscita

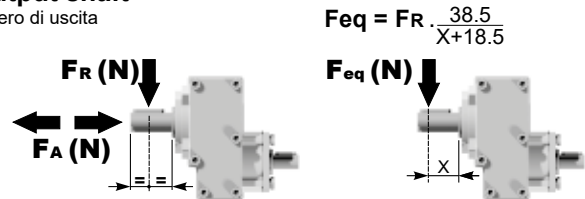

n_2	FA	FR	n_2	FA	FR	n_2	FA	FR
700	120	640	400	160	800	200	200	1020
600	140	700	300	175	880	140	225	1120

Input shaft

Albero in entrata

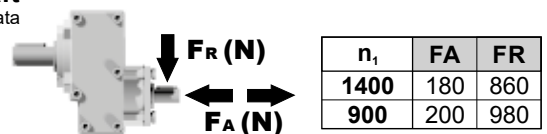

tab. 2

P311-F... Output flange
flange di uscita

Gearbox weight
peso riduttore **2.50 kg**

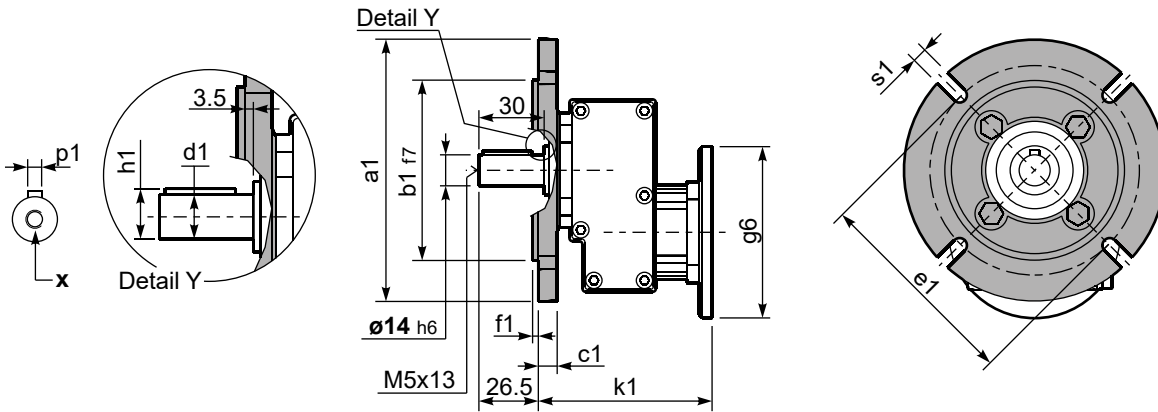

***Available output shaft / Albero di uscita**

	Shaft - d1	p1	h1	x
Standard	∅ 14x30	5	16	M5x13
On request A richiesta	∅ 19x40 ∅ 24x40	6 8	21.5 27	M6x16 M6x16

Available output flanges / flange di uscita

a1 ∅	b1	c1	e1	f1	s1	kit code
120	80	11.5	100	3	9*	KC30.9.010
140	95	11.5	115	3	9	KC30.9.011
160	110	11.5	130	3.5	9	KC30.9.012
200	130	11.5	165	3.5	11	KC30.9.013

*Holes position
posizione fori



P311-H1... With feet
Con piedini

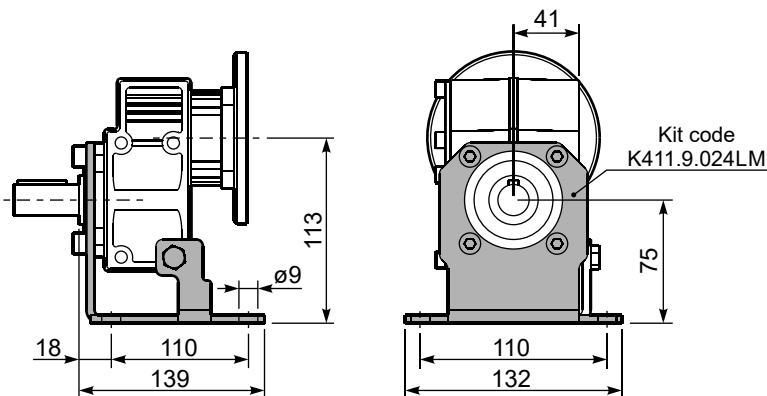

R311-N... Input Shaft
Albero in entrata

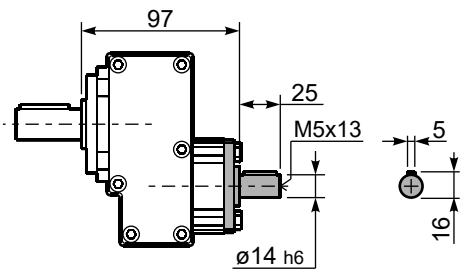

P311-N... Basic gearbox
Riduttore base

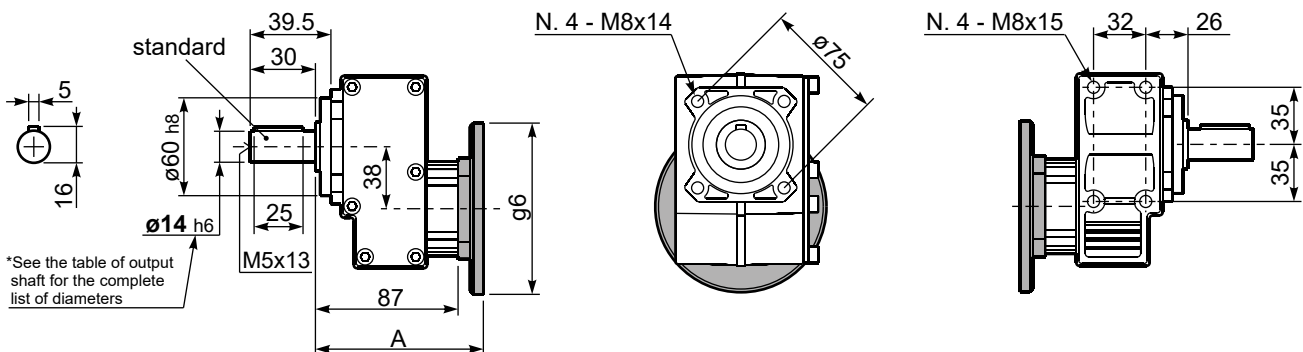

B14 Motor Flanges	A	g6	k1	kit code
56 B14	103	80	106.5	KC40.4.049
63 B14	105.5	90	109	K050.4.047
71 B14	103	105	106.5	K050.4.045

B5 Motor Flanges	A	g6	k1	kit code
63 B5	105.5	138	109	K050.4.041
71 B5	103	160	106.5	K050.4.042



QUICK SELECTION / Selezione veloce input speed (n₁) = 1400 min⁻¹

Output Speed n ₂ [min ⁻¹]	Ratio i	Motor power P _{1M} [kW]	Output torque M _{2M} [Nm]	Service factor f.s.	Nominal power P _{1R} [kW]	Nominal torque M _{2R} [Nm]	Available B5 motor flanges				Available B14 motor flanges			Output Shaft 	Ratios code	
							-B	-C	-D	-E	-Q	-R	-T			
891	1.57	1.5	16	1.3	1.9	20	B				C	C		2844	standard ø19	01
493	2.84	1.5	28	1.2	1.8	35	B				C	C		1954		02
425	3.29	1.5	33	1.2	1.7	38	B				C	C		1756		03
362	3.87	1.5	39	1.0	1.5	40	B				C	C		1558		04
303	4.62	1.5	46	1.0	1.5	47	B				C	C		1360		On request
222	6.30	1.1	46	1.0	1.1	46	B				C	C		1063		ø14
170	8.22	0.55	30	1.3	0.69	38	B				C	C		974		ø24
129	10.86	0.37	27	1.0	0.39	28	B				C	C		776		08

The dynamic efficiency is **0.98** for all ratios

Motor Flanges Available Flange Motore Disponibili
 B) Supplied with Reduction Bushing Fornito con Bussola di Riduzione
 B) Available on Request without reduction bushing Disponibile a Richiesta senza Bussola di Riduzione
 C) Motor Flange Holes Position Posizione Fori Flangia Motore

4

EN Unit **411A** is supplied with synthetic oil for lifetime lubrication, no maintenance is necessary. See table 1 for lubrication and recommended quantity. In table 2 please see possible radial loads and axial loads on the gearbox.

I Il riduttore **411A** viene fornito completo di olio sintetico per la lubrificazione permanente e non necessita di alcuna manutenzione. Vedi tab.1 per oli e quantità consigliati. In tab.2 sono presenti i carichi radiali e assiali applicabili al riduttore.

D Das Getriebe **411A** ist mit synthetischem Öl gefüllt und ist lebensdauergeschmiert. In Tabelle 1 ist die Schmiermenge und das empfohlene Schmiermittel angegeben. In Tabelle 2 sind die zulässigen Radial- und Axialbelastungen des Getriebes aufgeführt.

F Le réducteur **411A** est fourni complet avec de l'huile synthétique pour la lubrification permanente et ne nécessite aucun entretien. Voir tableau 1 concernant les huiles et les quantités conseillées. Les charges radiales et axiales applicables au réducteur sont précisées dans le tableau 2.

E El reductor tamaño **411A** se suministra, lubricado de por vida con aceite sintético y no requieren mantenimiento alguna. Ver tabla 1, para cantidades y aceites recomendados. En la tabla 2, se encuentran las cargas radiales y axiales admitidas por el reductor.

LUBRICATION 411A Oil Quantity 0.10 Lt.

SHELL Omala S4 WE 320 **ENI** Telium VSF 320

For all details on lubrication and plugs check our website tab. 1
Per maggiori dettagli su lubrificazione e tappi olio vedi il nostro sito web

RADIAL AND AXIAL LOADS

Output shaft

Albero di uscita

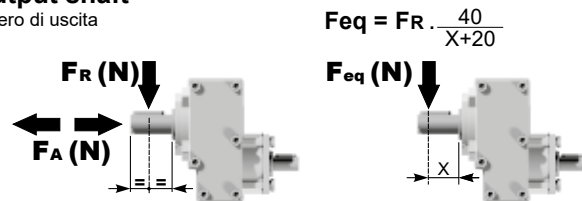

n ₂	FA	FR	n ₂	FA	FR	n ₂	FA	FR
700	182	910	400	230	1150	200	290	1450
600	200	1000	300	250	1250	140	320	1600

Input shaft

Albero in entrata

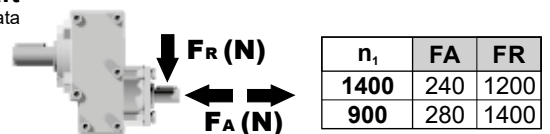

tab. 2

P411-F... Output flange
flange di uscita

Gearbox weight
peso riduttore **3.20 kg**

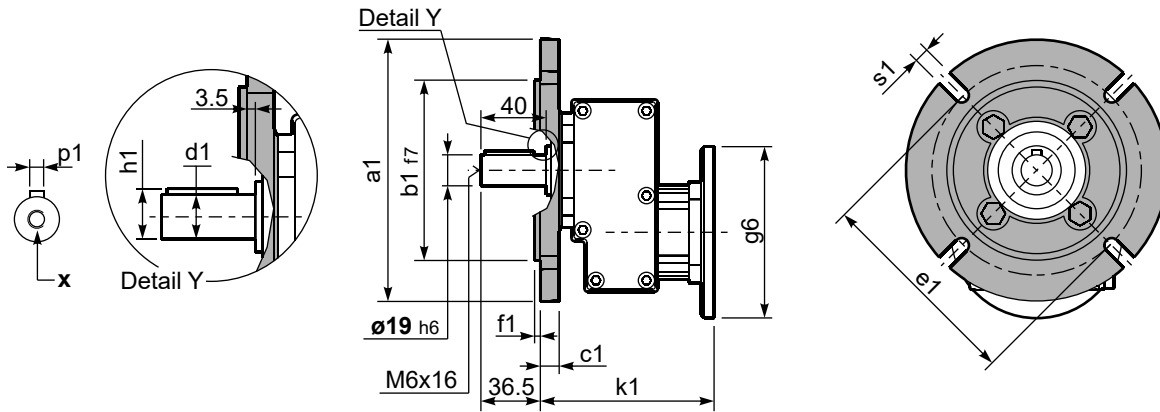

***Available output shaft / Albero di uscita**

	Shaft - d1	p1	h1	x
Standard	∅ 19x40	6	21.5	M6x16
On request A richiesta	∅ 14x30 ∅ 24x40	5 8	16 27	M5x13 M6x16

Available output flanges / flange di uscita

a1 ∅	b1	c1	e1	f1	s1	kit code
120	80	11.5	100	3	9*	KC30.9.010
140	95	11.5	115	3	9	KC30.9.011
160	110	11.5	130	3.5	9	KC30.9.012
200	130	11.5	165	3.5	11	KC30.9.013

*Holes position
posizione fori

P411-H1... With feet
Con piedini

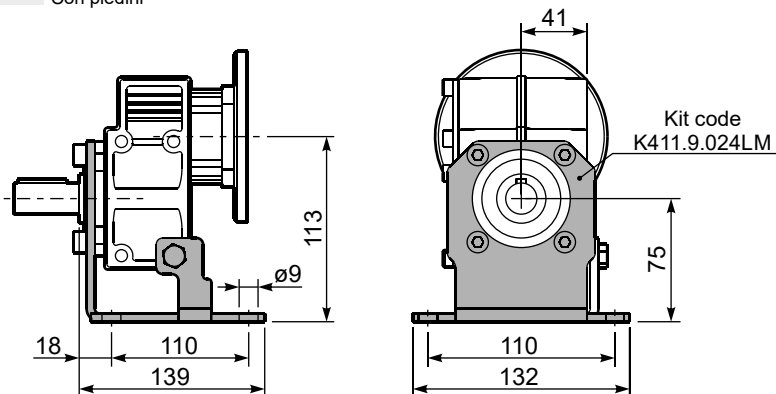

R411-N... Input Shaft
Albero in entrata

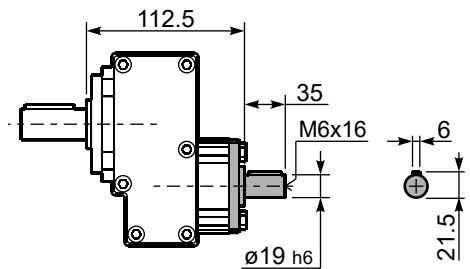

P411-N... Basic gearbox
Riduttore base

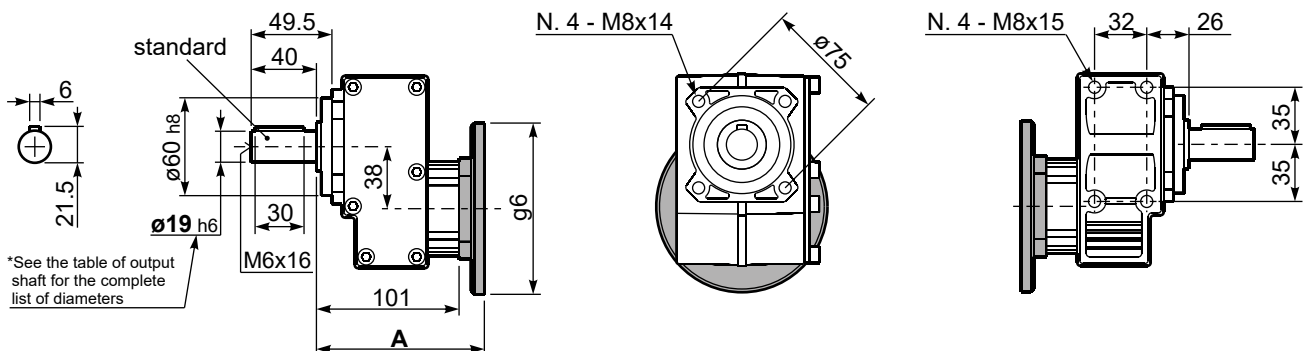

B5 Motor Flanges	A	g6	k1	kit code
63 B5	121.5	140	125	K063.4.041
71 B5	119.5	160	123	K063.4.042
80/90 B5	121.5	200	125	K063.4.043

B14 Motor Flanges	A	g6	k1	kit code
71 B14	119.5	105	123	K063.4.047
80 B14	121.5	120	125	K063.4.046
90 B14	121.5	140	125	K063.4.041



QUICK SELECTION / Selezione veloce

input speed (n_1) = 1400 min⁻¹

Output Speed n_2 [min ⁻¹]	Ratio i	Motor power P_{1M} [kW]	Output torque M_{2M} [Nm]	Service factor f.s.	Nominal power P_{1R} [kW]	Nominal torque M_{2R} [Nm]	Available B5 motor flanges					Available B14 motor flanges				Output Shaft 	Ratios code			
							-C	-D	-E	-F	-G	-R	-T	-U	-V					
							71	80	90	100 112	132	80	90	100 112	132					
1077	1.30	4	34	1.2	4.6	40	B										3039	standard ø28	01	
571	2.45	4	64	1.1	4.3	70	B										2049		02	
423	3.31	4	87	1.0	4.1	90	B										1653		03	
325	4.31	4	113	1.0	3.8	110	B										1356		04	
266	5.27	3	104	1.1	3.1	110	B										1158		On request ø24	05
184	7.63	2.2	111	1.0	2.2	110	B										861		06	
133	10.50	1.1	77	1.0	1.1	80	B										663		07	

The dynamic efficiency is **0.98** for all ratios

Motor Flanges Available
Flange Motore Disponibili

B) Supplied with Reduction Bushing
Fornito con Bussola di Riduzione

B) Available on Request without reduction bushing
Disponibile a Richiesta senza Bussola di Riduzione

C) Motor Flange Holes Position
Posizione Fori Flangia Motore

4

EN Unit **511A** is supplied with synthetic oil for lifetime lubrication, no maintenance is necessary. See table 1 for lubrication and recommended quantity. In table 2 please see possible radial loads and axial loads on the gearbox.

I Il riduttore **511A** viene fornito completo di olio sintetico per la lubrificazione permanente e non necessita di alcuna manutenzione. Vedi tab.1 per oli e quantità consigliati. In tab.2 sono presenti i carichi radiali e assiali applicabili al riduttore.

D Das Getriebe **511A** ist mit synthetischem Öl gefüllt und ist lebensdauergeschmiert. In Tabelle 1 ist die Schmiermenge und das empfohlene Schmiermittel angegeben. In Tabelle 2 sind die zulässigen Radial- und Axialbelastungen des Getriebes aufgeführt.

F Le réducteur **511A** est fourni complet avec de l'huile synthétique pour la lubrification permanente et ne nécessite aucun entretien. Voir tableau 1 concernant les huiles et les quantités conseillées. Les charges radiales et axiales applicables au réducteur sont précisées dans le tableau 2.

E El reductor tamaño **511A** se suministra, lubricado de por vida con aceite sintético y no requieren mantenimiento alguna. Ver tabla 1, para cantidades y aceites recomendados. En la tabla 2, se encuentran las cargas radiales y axiales admitidas por el reductor.

LUBRICATION 511A Oil Quantity 0.29 Lt.

SHELL Omala S4 WE 320

ENI Telium VSF 320

For all details on lubrication and plugs check our website

tab. 1

Per maggiori dettagli su lubrificazione e tappi olio vedi il nostro sito web

RADIAL AND AXIAL LOADS

Output shaft

Albero di uscita

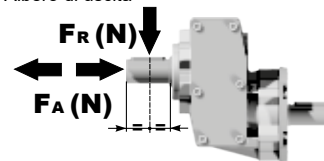

$$F_{eq} = FR \frac{47.5}{X+22.5}$$

F_{eq} (N)

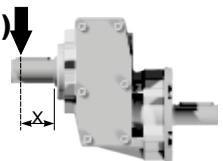

n_2	FA	FR	n_2	FA	FR	n_2	FA	FR
700	294	1470	400	370	1850	200	460	2300
600	320	1600	300	400	2000	140	510	2550

Input shaft

Albero in entrata

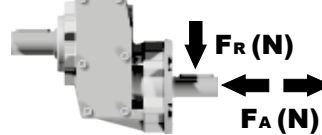

n_1	FA	FR
1400	400	2000
900	440	2200

tab. 2

P511-F... Output flanges
flange di uscita

Gearbox weight
peso riduttore **5.00 kg**

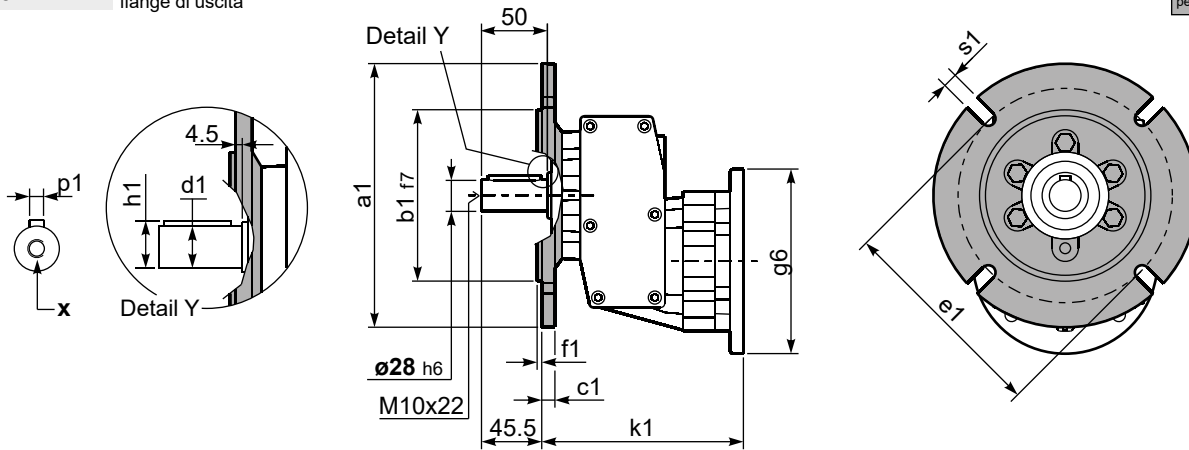

***Available output shaft / Alberi di uscita**

	Shaft - d1	p1	h1	x
Standard	ø 28x50	8	31	M10x22
On request A richiesta	ø 24x50	8	27	M8x19

Available output flanges / flange di uscita

a1 ø	b1	c1	e1	f1	s1	kit code
120	80	10	100	3	7	KC40.9.010
140	95	10	115	3	9	KC40.9.011
160	110	10	130	3.5	9	KC40.9.012
200	130	11	165	3.5	11	KC40.9.013
250	180	11.5	215	3.5	14	KC40.9.014

P511A-H1. With feet
Con piedini

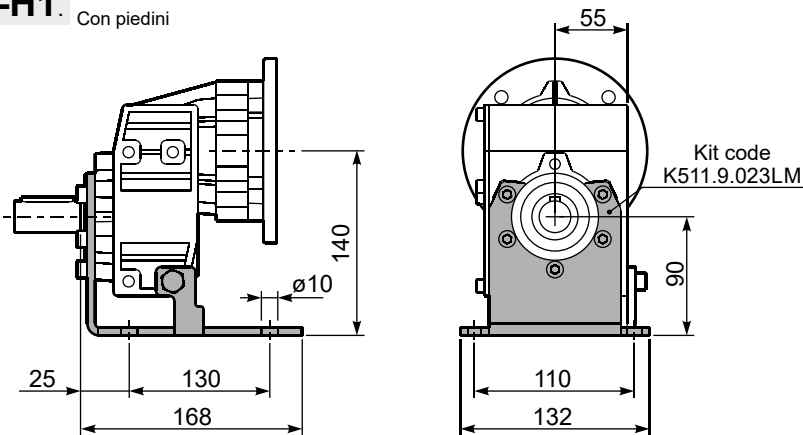

R511A-N... Input Shaft
Albero in entrata

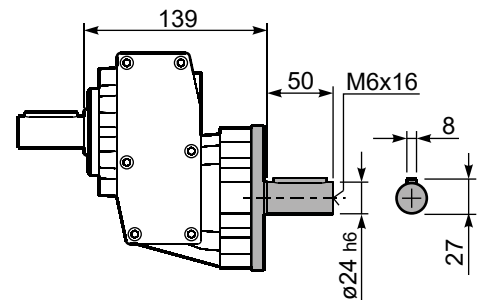

P511-N... Basic gearbox
Riduttore base

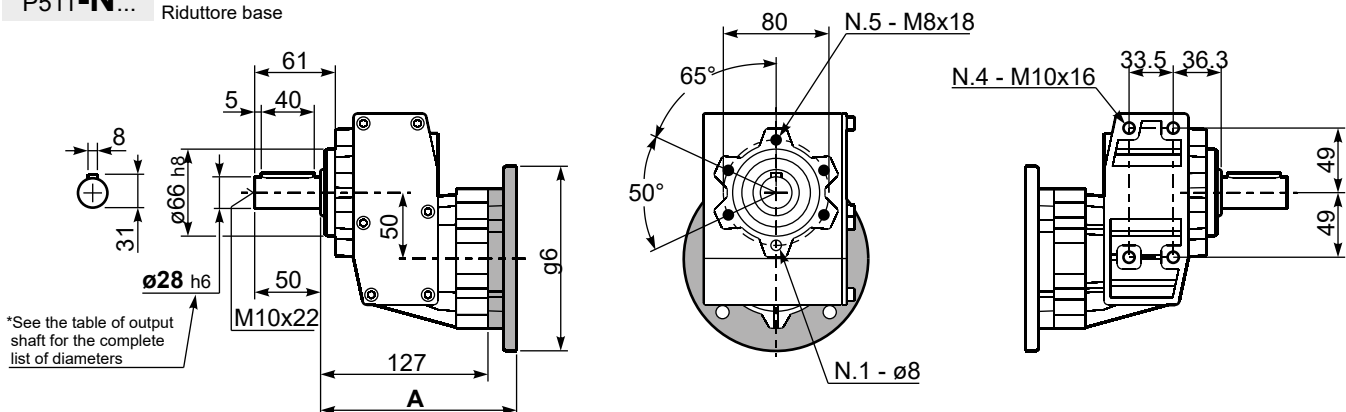

B5 Motor Flanges	A	g6	k1	kit code
71 B5	145.5	160	150	K023.4.041
80/90 B5	147.5	200	152	K023.4.042
100/112 B5	156.5	250	161	K023.4.043
132 B5	177.5	300	179	KC51.4.043

B14 Motor Flanges	A	g6	k1	kit code
80 B14	147.5	120	152	K085.4.046
90 B14	147.5	140	152	K085.4.045
100/112 B14	156.5	160	161	K085.4.047
132 B14	177.5	200	179	KC51.4.041

Aluminum in line gearboxes

A modular and compact product

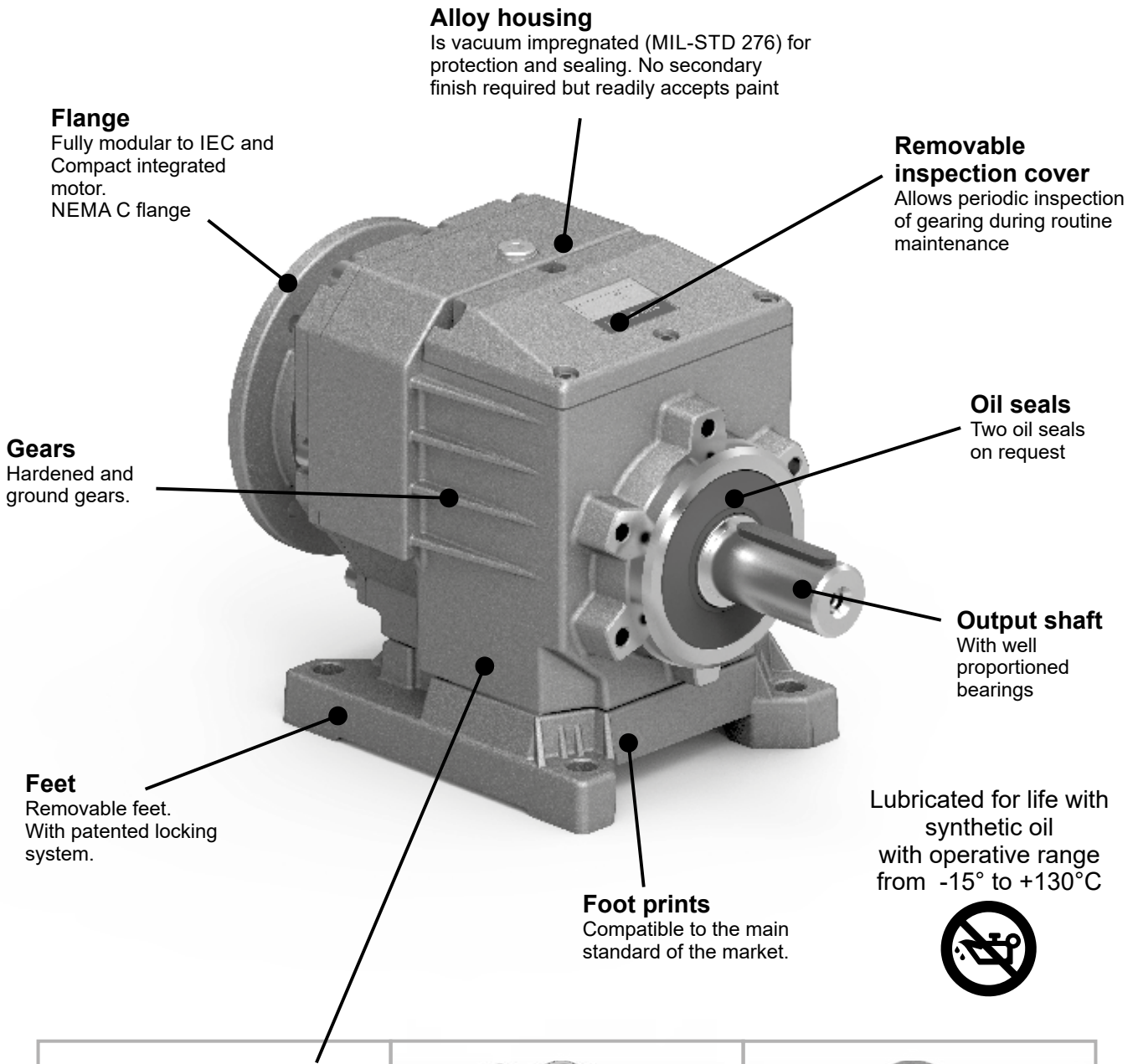

Flange
Fully modular to IEC and Compact integrated motor.
NEMA C flange

Alloy housing
Is vacuum impregnated (MIL-STD 276) for protection and sealing. No secondary finish required but readily accepts paint

Removable inspection cover
Allows periodic inspection of gearing during routine maintenance

Gears
Hardened and ground gears.

Oil seals
Two oil seals on request

Output shaft
With well proportioned bearings

Feet
Removable feet. With patented locking system.

Foot prints
Compatible to the main standard of the market.

Lubricated for life with synthetic oil with operative range from -15° to +130°C



Single-piece aluminum alloy housing

Combines light weight with high tensile strength. Precision machined for alignment of bearings and gearing

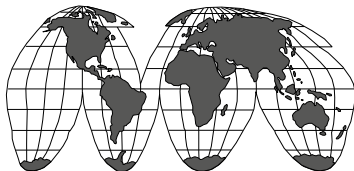
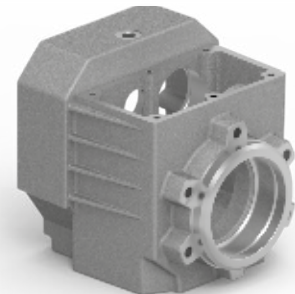
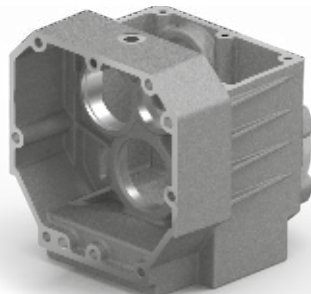

World wide sales network.

Specific type datasheet on page...

On page / A pagina / Auf Seite / À la page / En la página

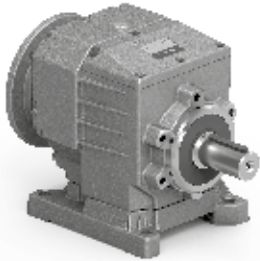

Types / Tipi
Tipen / Types
Tipos

5-5	5-7	5-9	5-11	5-13	5-15	5-17	5-19	5-21
202A 70Nm	302A 120Nm	412A 175Nm	413A 175Nm	452A 300Nm	512A 360Nm	513A 360Nm	612A 530Nm	613A 530Nm

On page / A pagina / Auf Seite / À la page / En la página

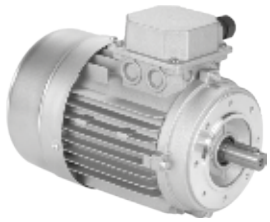

Types / Tipi
Tipen / Types
Tipos

M-1									
56A 56B	63A 63B	71A 71B	80A 80B	90S 90L	100LA 100LB	112M	132S 132M	160M 160L	180M 180L

Type - Tipo - Typ
Type - Tipo

Size - Grandezza - Grösse
Taille - Tamaño

Mounting - Montaggio
Montage - Fixation
Tipo de montaje

Ratio - Rapporto
Untersetzung - Reduction
Relación

P

412A

-F

7.33

Aluminum coaxial gear boxes
Riduttori coassiali in alluminio

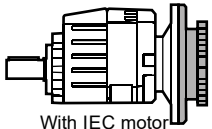

M

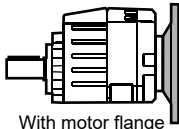

P

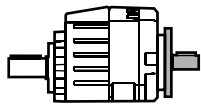

R

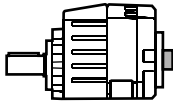

B

2 Stages
Riduzioni
Stufen
Trains
Etapas

3 Stages
Riduzioni
Stufen
Trains
Etapas

202A
302A
412A
452A
512A
612A

413A
513A
613A

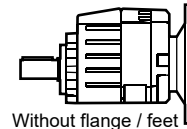

-N

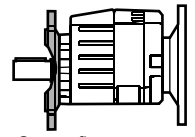

-F

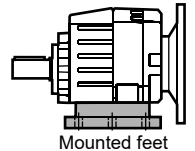









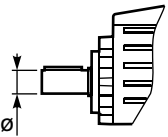
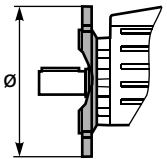

B..

Feet / piedini		G	H	R	L	L1	S
Feet Code	Market reference						
B1	112	18	85	110	87	50	
B2	212/3	18	100	130	107.5		
S1	17	18	75	110	90+20		
S2	27	25	90	110	130		
M1	42/3	25	80	110+120	85		
L4	04	13	80	105			
L5	05	16	100	125			

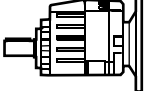
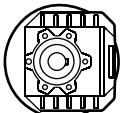
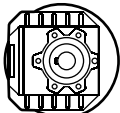
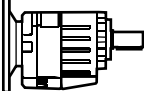
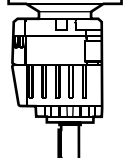
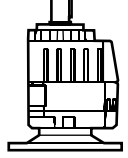
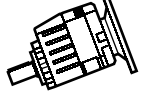
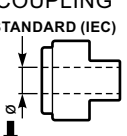
You see feet code in the chart of the dimensions
Vedi codice piede nella tabella delle dimensioni

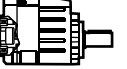

On request we can deliver our products according to the ATEX
A richiesta possiamo fornire i nostri prodotti secondo le normative ATEX
Auf Anfrage können wir unsere Produkte den Richtlinien ATEX entsprechend liefern
Sur demande nos produits peuvent se conformer à la réglementation ATEX
A pedido, se pueden enviar nuestros productos de acuerdo con las normas ATEX.

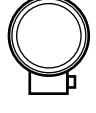
Output shaft Albero uscita Abtriebswelle Arbre de sortie Eje en salida	Output flange Flangia uscita Ausgangsflansch Bride de sortie Brida en salida	Motor size - Grandezza motore Motor Grösse Grandeur moteur - Tamaño motor	Mounting position Posizione montaggio Einbaulage Position de montage Position de montage	Input bore Foro entrata Eingangshohlwelle Trou d'entree Eje hueco de entrada	Terminal box position Posizione morsettiere Klemmkastenlage Position boîte à bornes Posición caja de bornes
<p>V</p>  <p>→ STANDARD</p> <p>202A</p> <p>S ⇒ Ø14 B → Ø16 D ⇒ Ø20 V ⇒ Ø25</p> <p>302A</p> <p>S ⇒ Ø14 B ⇒ Ø16 C ⇒ Ø19 D → Ø20 E ⇒ Ø24 V ⇒ Ø25</p> <p>412A 413A</p> <p>B ⇒ Ø16 C ⇒ Ø19 D ⇒ Ø20 E ⇒ Ø24 V → Ø25</p> <p>452A 512A 513A</p> <p>E ⇒ Ø24 V ⇒ Ø25 G ⇒ Ø28 H → Ø30 I ⇒ Ø35</p> <p>612A 613A</p> <p>G ⇒ Ø28 H ⇒ Ø30 I → Ø35 L ⇒ Ø38 M ⇒ Ø40</p>	<p>2</p>  <p>N Senza flangia Without flange</p> <p>202A 302A</p> <p>1 ⇒ Ø120 2 → Ø140 3 ⇒ Ø160 4 ⇒ Ø200</p> <p>412A 413A</p> <p>1 ⇒ Ø120 2 → Ø140 3 ⇒ Ø160 4 ⇒ Ø200 5 ⇒ Ø250</p> <p>452A 512A 513A</p> <p>3 ⇒ Ø160 4 ⇒ Ø200 5 → Ø250</p> <p>612A 613A</p> <p>3 ⇒ Ø160 4 ⇒ Ø200 5 → Ø250</p>	<p>-C</p> <p>Flange Flangia</p>  <p>B5</p> <p>-A=56 (Ø120) -B=63 (Ø140) -C=71 (Ø160) -D=80 (Ø200) -E=90 (Ø200) -F=100 (Ø250) -G=132 (Ø300)</p> <p>Type R Tipo R</p>  <p>202A 413A</p> <p>-1 ⇒ Ø14 -2 ⇒ Ø19 -3 ⇒ Ø24</p> <p>302A 412A 513A 613A</p> <p>452A 512A 612A</p> <p>-3 ⇒ Ø24</p> <p>Without flange Senza flangia</p>  <p>B14</p> <p>-O=56 (Ø80) -P=63 (Ø90) -Q=71 (Ø105) -R=80 (Ø120) -T=90 (Ø140) -U=100 (Ø160) -V=132 (Ø200)</p> <p>With coupling</p> <p>202A 413A</p> <p>-Z ⇒ Ø9 (56B5) -0 ⇒ Ø11 (63B5) -1 ⇒ Ø14 (71B5) -1 ⇒ Ø14 (71B5) -2 ⇒ Ø19 (80B5) -2 ⇒ Ø19 (80B5) -3 ⇒ Ø24 (90B5) -3 ⇒ Ø24 (90B5) -4 ⇒ Ø28 (100B5) -4 ⇒ Ø28 (100B5)</p> <p>302A 412A 513A 613A</p> <p>452A 512A 612A</p> <p>-2 ⇒ Ø19 (80B5) -3 ⇒ Ø24 (90B5) -4 ⇒ Ø28 (100B5)</p> <p>Brushless</p> <p>BB=50/70-M5 BC=60/75-M5 BD=70/90-M6 BE=80/100-M6 BF=95/115-M8 BG=110/145-M8 BH=130/165-M8</p>	<p>B3</p>  <p>B3 STANDARD</p>  <p>B6</p>  <p>B7</p>  <p>B8</p>  <p>V5</p>  <p>V6</p>  <p>V8</p>	<p>ST</p> <p>ST standard bore foro standard</p> <p>COUPLING STANDARD (IEC)</p>  <p>-A = 9mm -B = 11mm -C = 14mm -D = 19mm -E = 24mm -F = 28mm</p> <p>BRUSHLESS *</p>  <p>-2 = 11mm -3 = 14mm -4 = 19mm -5 = 22mm -6 = 24mm</p> <p>-0 Ready for input coupling Predisposto per giunto</p>  <p>* With reduction bushing where applicable Con bussola di riduzione dove prevista</p>	<p>With Type M specify terminal box position Con tipo M specificare posizione morsettiere</p>  <p>A</p>  <p>B STANDARD</p>  <p>C</p>  <p>D</p>

POTENZA RICHIESTA / REQUIRED POWER / ERFORDERLICHE LEISTUNG / PUISSANCE NECESSAIRE / POTENCIA NECESARIA

Lifting / sollevamento / hubantriebe / levage / elevación	$P [KW] = \frac{M [Kg] \cdot g [9.81] \cdot v [m / s]}{1000}$
Rotation / rotazione / drehung / rotation / rotação	$P [KW] = \frac{M [Nm] \cdot n [rpm]}{9550}$
Linear movement / traslazione / linearbewegung / translation / translacion	$P [KW] = \frac{F [N] \cdot v [m / s]}{1000}$

TORQUE / COPPIA / DREHMOMENT / COUPLE / PAR

	$M [Nm] = \frac{9550 \cdot P[KW]}{n [rpm]}$
	$M [lb in] = \frac{63030 \cdot P[HP]}{n [rpm]}$

5

RADIAL LOADS / CARICHI RADIALI / RADIALE - UND AXIALLASTEN / CHARGES RADIALES / CARGA RADIAL Y AXIAL

- Radial load generated by external transmissions keyed onto input and/or output shafts.
- Forza radiale generata da organi di trasmissione calettati sugli alberi di ingresso e/o uscita.
- Belastungen der Antriebs- bzw. Abtriebswellen durch von aussen eingebrachte Radiallasten.
- Charge radiale générée par la transmissions calés sur les entrées et / ou des arbres de sortie
- Cargas radiales, generada por transmisiones externas, aplicadas sobre los ejes de entrada y/o salida



	$F_R [N] = \frac{M [Nm] \cdot 2000}{d [mm]} \cdot f_k$	$F_R [N] = \frac{M [lb in] \cdot 8.9}{d [in]} \cdot f_k$
M	Momento torcente / Output torque / Abtriebsdrehmoment / Couple / Par torsion	
d	Diametro primitivo / Diam. of driving element / Durchmesser der Abtriebseinheit / Diamètre primitif / Diámetro primitivo	
f_k	Coefficiente di trasformazione / Factor / Faktor / Coefficient de transmission / Coeficiente de transmisión 1.15 Ingranaggi / Gearwheels / Zahnrad / Engrenage / Engranaje 1.25 Catena / Chain sprockets / Antriebskette / Chaîne / Cadena 1.75 Cinghia Trapezoidale / Narrow v-belt pulley / Keilriemen / Courroie trap. / Correa trapezoidal 2.50 Cinghia piatta / Flat-belt pulley / Flachzahnriem. / Courroie crantée / Correa plana	

- If your application requires higher radial loads, contact our technical office. Higher load may be possible.
- Nel caso la vostra applicazione richieda carichi radiali superiori consultare il nostro ufficio tecnico, valori maggiori possono essere accettati.
- Wenn Ihre Anwendung höhere Radialbelastungen erfordert, so wenden Sie sich bitte an unser technischen Büro.
- Si votre application demande des charges radiales supérieures, s'adresser à notre bureau technique.
- En el caso en que una aplicación exija una carga radial superior a la especificada en el catálogo, consultar a nuestra oficinas técnica.

How to select a gearbox / Come selezionare un riduttore / Wie wählt man ein Getriebe
Comment sélectionner un réducteur / Cómo seleccionar un reductor

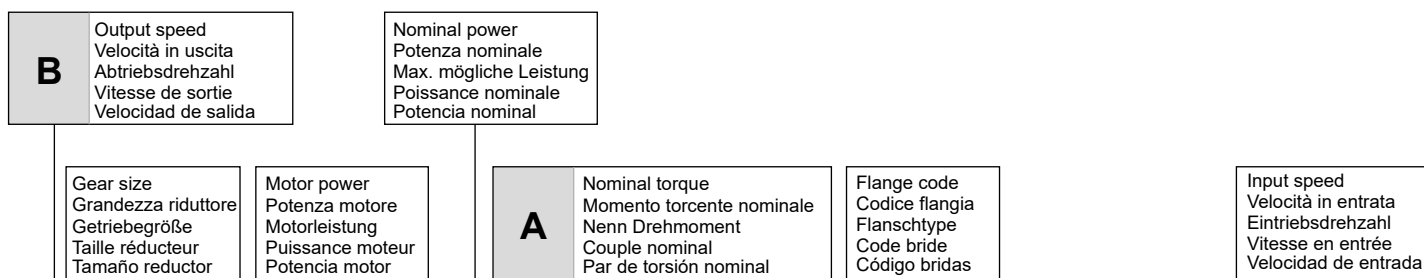

412A

**Coaxial - Gear
160Nm**

Rating - Aluminum COAXIAL GEARBOXES



QUICK SELECTION / Selezione veloce

input speed (n_1) = 1400 min⁻¹

Output Speed n_2 [min ⁻¹]	Ratio i	Motor power P_{1M} [kW]	Output torque M_{2M} [Nm]	Service factor f.s.	Nominal power P_{1R} [kW]	Nominal torque M_{2R} [Nm]	Available B5 motor flanges				Available B14 motor flanges				Output Shaft		
							-B	-C	-D	-E	-Q	-R	-T	-U			Ratio code
398	3.52	3	69	1.2	3.5	80	B				C	C			2821		01
320	4.37	3	86	1.0	3.1	90	B				C	C			2818		02
252	5.55	3	109	0.9	2.8	100	B				C	C			2813		03
220	6.36	2.2	92	1.0	2.3	95	B				C	C			1921		04
191	7.33	2.2	106	1.1	2.5	120	B				C	C			2812		05

C Ratio
Rapporto
Untersetzung
Rapport de réduction
Relación

Output shaft diam.
Diam. albero uscita
Durchmesser abtriebswelle
Diametre arbre lent
Diametro eje de salida

Notes
Note
Anmerkungen
Note
Notas

Transmitted torque
Momento torcente trasmesso
Mögliche Drehmomente
Couple de sortie
Par transmitido

Service factor
Fattore di servizio
Betriebsfaktor
Facteur de service
Factor de servicio

Type of load and starts per hour Tipo di carico e avviamenti per ora		Oper. hours per day Ore di funz. giorn.		
		3 h	10 h	24 h
Continuous or intermittent appl. with start / hour Applicazione cont. o interm. con n.ro operazioni/ora	Uniform / Uniforme	0.8	1	1.25
	Moderate / Moderato	1	1.25	1.5
	Heavy / Forte	1.25	1.5	1.75
Intermittent application with start / hour Applicazione intermittente con n.ro operazioni/ora	Uniform / Uniforme	1	1.25	1.5
	Moderate / Moderato	1.25	1.5	1.75
	Heavy / Forte	1.5	1.75	2.15

D	Motor flange available Flange disponibili Erhältliche Motorflansche Brides disponibles Bridas disponibles	
B)	Mounting with reduction ring Montaggio con boccia di riduzione Reduzierhülsen Montage avec douille de réduction Montaje con casquillo de reducción	
C)	Motor flangeholes position/terminal box position Posizione fori flangia/basetta motore Bohrungsposition am Motorflansch/-sockel Position trous bride/barrette à bornes moteur Posición agujeros brida / base motor	
B)	Available without reduction bushes Disponibile anche senza boccia Auch ohne Reduzierbuchse verfügbar Disponible aussi sans douille de réduction Disponible tambien sin casquillo	

A	Select required torque (according to service factor)	Seleziona la coppia desiderata (comprensiva del fattore di servizio)	Max. Drehmoment in Bezug zum Betriebsfaktor	Sélectionner le couple souhaité (comprenant le facteur de service)	Seleccionar el par deseado (incluyendo el factor de servicio)
B	Select output speed	Seleziona la velocità in uscita	Ausgewählte Abtriebsdrehzahl	Sélectionner la vitesse de sortie	Seleccionar la velocidad de salida
C	On the same line of selected geared motor, you can find the gear ratio	Sulla riga corrispondente alla motorizzazione prescelta si può rilevare il rapporto di riduzione	Auf der gleichen Linie wie die ausgewählte Motorleistung steht auch die Getriebeuntersetzung	Sur la ligne correspondante à la motorisation pré-choisie on peut relever le rapport de réduction	En la línea correspondiente al motor preseleccionado es posible encontrar la relación de reducción
D	Select motor flange available (if requested)	Scegli la flangia disponibile (se richiesta)	Erhältliche Motorflansche (auf Anfrage)	Choisir la bride disponible (si elle est demandée)	Seleccionar la brida disponible (sobre pedido)



QUICK SELECTION / Selezione veloce The dynamic efficiency is **0.96** for all ratios **input speed (n₁) = 1400 min⁻¹**

Output Speed n ₂ [min ⁻¹]	Ratio i	Motor power P _{1M} [kW]	Output torque M _{2M} [Nm]	Service factor f.s.	Nominal power P _{1R} [kW]	Nominal torque M _{2R} [Nm]	Available B5 motor flanges		Available B14 motor flanges			Output Shaft \varnothing Ratios code	
							-B	-C	-O	-P	-Q		
							63	71*	56	63	71		
407	3.44	0.55**	12	2.0	1.1	25			C	C		2821	01
327	4.28	0.55**	15	1.9	1.1	30			C	C		2818	02
257	5.45	0.55**	20	2.0	1.1	40			C	C		2815	03
225	6.23	0.55**	23	2.0	1.1	45			C	C		1921	04
194	7.20	0.55**	26	1.9	1.1	50			C	C		2812	05
181	7.74	0.55**	28	1.8	0.99	50			C	C		1918	06
142	9.85	0.55**	36	1.7	0.93	60			C	C		1915	07
123	11.42	0.55**	41	1.5	0.80	60			C	C		1715	08
107	13.03	0.55**	47	1.3	0.70	60			C	C		1912	09
93	15.10	0.37	37	1.6	0.61	60			C	C		1712	10
86	16.20	0.37	39	1.5	0.57	60			C	C		1910	11
75	18.78	0.37	45	1.3	0.49	60			C	C		1710	12
66	21.15	0.37	51	1.2	0.43	60			C	C		1312	13
64	21.84	0.37	53	1.1	0.42	60			C	C		1015	14
53	26.31	0.37	64	0.9	0.35	60			C	C		1310	15
48.5	28.88	0.37	70	1.0	0.37	70			C	C		1012	16
39	35.91	0.37	87	0.8	0.30	70			C	C		1010	17
37.1	37.69	0.25	62	1.1	0.28	70			C	C		912	18
29.9	46.87	0.25	77	0.9	0.23	70			C	C		910	19
28.1	49.76	0.25	81	0.9	0.21	70			C	C		712	20
22.6	61.89	0.18	77	0.9	0.17	70			C	C		710	21

** Concerning a reduced dimensions electric motor. * Nel montaggio P la flangia può superare l'ingombro massimo dei piedi. Eventualmente utilizzare la flangia B14 Riferito a motore con grandezza ridotta * In the P mounting the B5 motor flange can exceed the foot maximum dimensions. Possibly use the flange B14

A) Motor Flanges Available Flange Motore Disponibili **B) Supplied with Reduction Bushing** Fornito con Bussola di Riduzione **C) Available on Request without reduction bushing** Disponibile a Richiesta senza Bussola di Riduzione **D) Motor Flange Holes Position** Posizione Fori Flangia Motore

EN Unit **202A** is supplied with synthetic oil for lifetime lubrication, no maintenance is necessary. See table 1 for lubrication and recommended quantity. In table 2 please see possible radial loads and axial loads on the gearbox.

I Il riduttore **202A** viene fornito completo di olio sintetico per la lubrificazione permanente e non necessita di alcuna manutenzione. Vedi tab.1 per oli e quantità consigliati. In tab.2 sono presenti i carichi radiali e assiali applicabili al riduttore.

D Das Getriebe **202A** ist mit synthetischem Öl gefüllt und ist lebensdauergeschmiert. In Tabelle 1 ist die Schmiermenge und das empfohlene Schmiermittel angegeben. In Tabelle 2 sind die zulässigen Radial - und Axialbelastungen des Getriebes aufgeführt.

F Le réducteur **202A** est fourni complet avec de l'huile synthétique pour la lubrification permanente et ne nécessite aucun entretien. Voir tableau 1 concernant les huiles et les quantités conseillées. Les charges radiales et axiales applicables au réducteur sont précisées dans le tableau 2.

E El reductor tamaño **202A** se suministra, lubricado de por vida con aceite sintético y no requieren mantenimiento alguna. Ver tabla 1, para cantidades y aceites recomendados. En la tabla 2, se encuentran las cargas radiales y axiales admitidas por el reductor.

LUBRICATION 202A Oil Quantity 0.15 Lt.

SHELL Omala S4 WE 320 **AGIP** Telium VSF 320

For all details on lubrication and plugs check our website **tab. 1**
Per maggiori dettagli su lubrificazione e tappi olio vedi il nostro sito web

RADIAL AND AXIAL LOADS

Output shaft
Albero di uscita

$F_{eq} = F_R \cdot \frac{35.7}{X+20.7}$

n ₂	FA	FR	n ₂	FA	FR	n ₂	FA	FR
300	140	700	140	246	1320	70	340	1700
250	151	756	120	270	1350	40	380	1900
200	185	924	85	300	1500	15	-	-

Input shaft
Albero in entrata

n ₁	FA	FR
1400	140	700
900	160	800
500	190	950

tab. 2



QUICK SELECTION / Selezione veloce input speed (n_1) = 1400 min⁻¹

Output Speed n_2 [min ⁻¹]	Ratio i	Motor power P_{1M} [kW]	Output torque M_{2M} [Nm]	Service factor f.s.	Nominal power P_{1R} [kW]	Nominal torque M_{2R} [Nm]	Available B5 motor flanges				Available B14 motor flanges			Output Shaft 	Ratios code
							-B	-C	-D	-E	-Q	-R	-T		
							63	71*	80*	90*	71	80	90		
407	3.44	1.5	34	1.0	1.6	35	B				C	C		2821	01
327	4.28	1.5	42	1.0	1.4	40	B				C	C		2818	02
257	5.45	1.5	53	1.0	1.5	52	B				C	C		2815	03
225	6.23	1.5	61	1.1	1.7	70	B				C	C		1921	04
194	7.20	1.5	71	1.0	1.5	70	B				C	C		2812	05
181	7.74	1.5	76	1.1	1.6	80	B				C	C		1918	06
142	9.85	1.5	97	1.0	1.5	95	B				C	C		1915	07
123	11.42	1.5	112	1.0	1.5	115	B				C	C		1715	08
107	13.03	1.1	93	1.2	1.3	114	B				C	C		1912	09
93	15.10	1.1	108	1.1	1.2	114	B				C	C		1712	10
86	16.20	0.75	80	1.3	1.0	107	B				C	C		1910	11
75	18.78	0.75	92	1.2	0.87	107	B				C	C		1710	12
66	21.15	0.75	104	1.1	0.82	114	B				C	C		1312	13
64	21.84	0.75	107	1.1	0.83	119	B				C	C		1015	14
53	26.31	0.55	95	1.1	0.62	107	B				C	C		1310	15
48.5	28.88	0.55	105	1.1	0.60	114	B				C	C		1012	16
39	35.91	0.37	87	1.2	0.46	107	B				C	C		1010	17
37.1	37.69	0.37	91	1.1	0.41	102	B				C	C		912	18
29.9	46.87	0.37	113	0.9	0.35	107	B				C	C		910	19
28.1	49.76	0.25	81	1.2	0.31	101	B				C	C		712	20
22.6	61.89	0.25	101	1.1	0.26	107	B				C	C		710	21

The dynamic efficiency is **0.96** for all ratios

*Nel montaggio P la flangia può superare l'ingombro massimo dei piedi. Eventualmente utilizzare la flangia B14
* In the P mounting the B5 motor flange can exceed the foot maximum dimensions. Possibly use the flange B14

A) Motor Flanges Available Flange Motore Disponibili **B) Supplied with Reduction Bushing** Fornito con Bussola di Riduzione **C) Available on Request without reduction bushing** Disponibile a Richiesta senza Bussola di Riduzione **D) Motor Flange Holes Position** Posizione Fori Flangia Motore

EN Unit **302A** is supplied with synthetic oil for lifetime lubrication, no maintenance is necessary. See table 1 for lubrication and recommended quantity. In table 2 please see possible radial loads and axial loads on the gearbox.

I Il riduttore **302A** viene fornito completo di olio sintetico per la lubrificazione permanente e non necessita di alcuna manutenzione. Vedi tab.1 per oli e quantità consigliati. In tab.2 sono presenti i carichi radiali e assiali applicabili al riduttore.

D Das Getriebe **302A** ist mit synthetischem Öl gefüllt und ist lebensdauergeschmiert. In Tabelle 1 ist die Schmiermenge und das empfohlene Schmiermittel angegeben. In Tabelle 2 sind die zulässigen Radial - und Axialbelastungen des Getriebes aufgeführt.

F Le réducteur **302A** est fourni complet avec de l'huile synthétique pour la lubrification permanente et ne nécessite aucun entretien. Voir tableau 1 concernant les huiles et les quantités conseillées. Les charges radiales et axiales applicables au réducteur sont précisées dans le tableau 2.

E El reductor tamaño **302A** se suministra, lubricado de por vida con aceite sintético y no requieren mantenimiento alguna. Ver tabla 1, para cantidades y aceites recomendados. En la tabla 2, se encuentran las cargas radiales y axiales admitidas por el reductor.

LUBRICATION 302A Oil Quantity 0.15 Lt.

SHELL Omala S4 WE 320 **AGIP** Telium VSF 320

For all details on lubrication and plugs check our website **tab. 1**
Per maggiori dettagli su lubrificazione e tappi olio vedi il nostro sito web

RADIAL AND AXIAL LOADS

Output shaft
Albero di uscita

$F_{eq} = F_R \cdot \frac{35.7}{X+20.7}$

n_2	FA	FR	n_2	FA	FR	n_2	FA	FR
300	140	700	140	246	1320	70	340	1700
250	151	756	120	270	1350	40	380	1900
200	185	924	85	300	1500	15	-	-

Input shaft
Albero in entrata

n_1	FA	FR
1400	226	1130
900	264	1320
500	322	1610

tab. 2

Gearbox weight **3.5 kg**
 With flange
 peso riduttore **4.0 Kg**
 With feet

P302A **B1**...
 With feet
 Con piedini

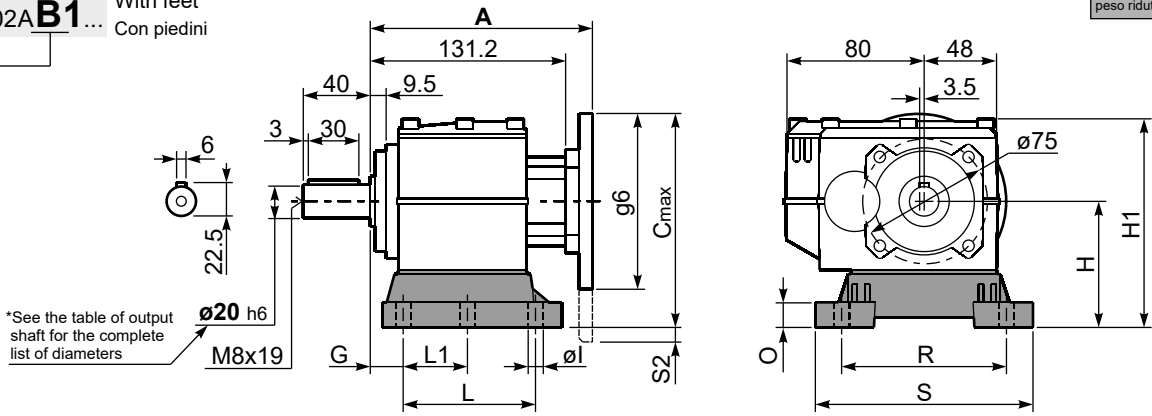

*See the table of output shaft for the complete list of diameters

Feet Code	Market reference	G	H	R	L	L1	S	H1	O	ø1	S2 only with motor flange	B5 max. Flange	kit code
B1	112	18	85	110	87	50	130	133	15	9	15 80/90B5	-	KC30.9.022
B2	212/3	18	100	130	107.5	60	155	145	5	11	3.5 80/90B5	-	KC30.9.023LM
S1	17-32	18	75	110	110	50	130	123	15	9	5 71B5	71B5	KC30.9.024

Other feet are available, see our web site
 Sono disponibili altri piedini, consulta il nostro sito web

A see on page bottom

Most popular types
 Tipi più diffusi

P302A-**F**...
 Output flanges
 flange di uscita

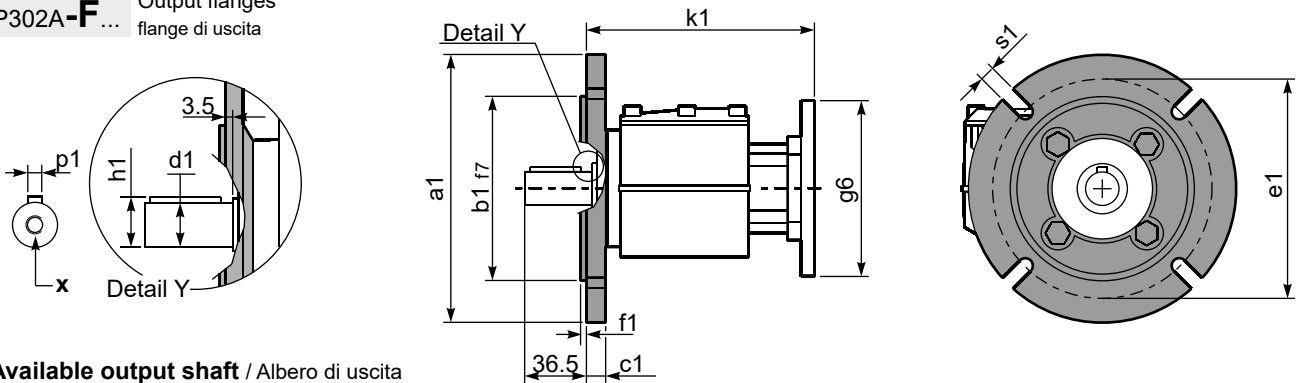

*Available output shaft / Albero di uscita

	Shaft - d1	p1	h1	x
Standard	ø 20x40	6	22.5	M8x19
On request A richiesta	ø 14x30	5	16	M6x16
	ø 16x40	5	18	M6x16
	ø 19x40	6	21.5	M6x16
	ø 24x50	8	27	M8x19
	ø 25x50	8	28	M8x19

Available output flanges / flange di uscita

a1 ø	b1	c1	e1	f1	s1	kit code
120	80	11.5	100	3	9*	KC30.9.010
140	95	11.5	115	3	9	KC30.9.011
160	110	11.5	130	3.5	9	KC30.9.012
200	130	11.5	165	3.5	11	KC30.9.013

* Holes position
 Posizione fori

With flange and feet only on request. Ask for compatibility

P302A-**N**...
 Basic gearbox
 Riduttore base

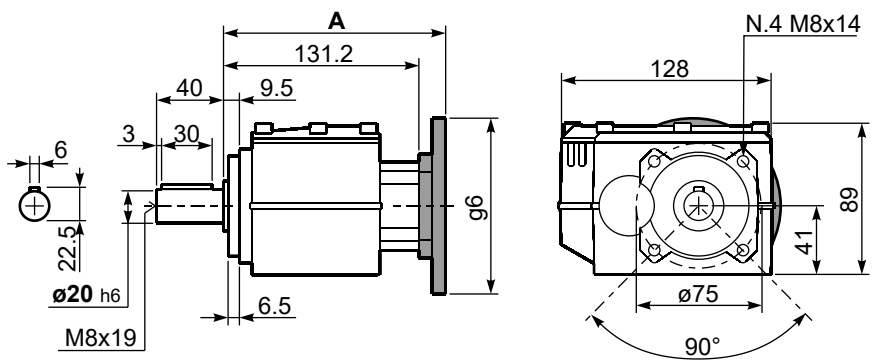

R302A-**N**...
 Input Shaft
 Albero in entrata

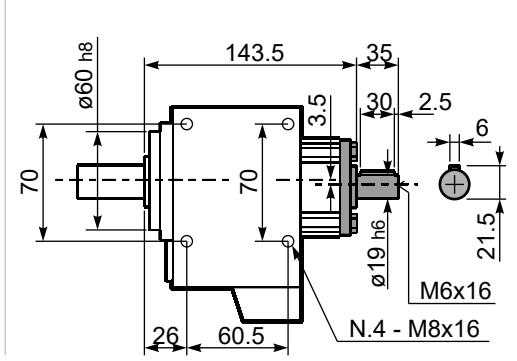

B5 Motor Flanges	A	C _{max}	g6	k1	kit code
63 B5	151.7	170	140	155.2	K063.4.041
71 B5	149.7	180	160	153.2	K063.4.042
80/90 B5	151.7	200	200	155.2	K063.4.043

B14 Motor Flanges	A	C _{max}	g6	k1	kit code
71 B14	149.7	152.5	105	153.2	K063.4.047
80 B14	151.7	160	120	155.2	K063.4.046
90 B14	151.7	170	140	155.2	K063.4.041



QUICK SELECTION / Selezione veloce

input speed (n₁) = 1400 min⁻¹

Output Speed n ₂ [min ⁻¹]	Ratio i	Motor power P _{1M} [kW]	Output torque M _{2M} [Nm]	Service factor f.s.	Nominal power P _{1R} [kW]	Nominal torque M _{2R} [Nm]	Available B5 motor flanges					Available B14 motor flanges				Output Shaft		
							-B	-C	-D	-E	-F	-Q	-R	-T	-U			Ratios code
							63	71	80*	90*	100*	112	71	80	90	100	112	
398	3.52	3	68	1.2	3.5	80	B					C	C			2821		01
321	4.37	3	84	1.1	3.1	90	B					C	C			2818		02
252	5.56	3	107	0.9	2.7	100	B					C	C			2813		03
220	6.36	2.2	90	1.2	2.5	105	B					C	C			1921		04
191	7.33	2.2	104	1.2	2.5	120	B					C	C			2812		05
177	7.89	2.2	112	1.2	2.5	130	B					C	C			1918		06
139	10.06	2.2	143	1.2	2.5	165	B					C	C			1913		08
120	11.66	2.2	166	1.0	2.2	165	B					C	C			1713	standard	09
106	13.26	1.5	130	1.3	1.9	165	B					C	C			1912	ø25	10
102	13.68	1.5	134	1.2	1.8	165	B					C	C			1513		25
91	15.37	1.5	151	1.1	1.6	165	B					C	C			1712	ø16	11
86	16.33	1.5	160	1.0	1.5	165	B					C	C			1313	ø19	26
78	18.04	1.5	177	0.9	1.4	165	B					C	C			1512	ø20	23
65	21.54	1.1	154	1.1	1.2	165	B					C	C			1312	ø24	14
63	22.29	1.1	160	1.0	1.1	165	B					C	C			1013	On request	15
53	26.31	0.75	129	1.2	0.90	155	B					C	C			1310		16
47.6	29.40	0.75	144	1.1	0.86	165	B					C	C			1012		17
39	35.91	0.55	130	1.2	0.66	155	B					C	C			1010		18
36.5	38.37	0.55	139	1.2	0.66	165	B					C	C			912		19
29.9	46.87	0.55	170	0.9	0.51	155	B					C	C			910		20
27.6	50.67	0.37	123	1.1	0.41	137	B					C	C			712		21
22.6	61.89	0.37	150	1.0	0.38	155	B					C	C			710		22

The dynamic efficiency is **0.96** for all ratios

*Nel montaggio P la flangia può superare l'ingombro massimo dei piedi. Eventualmente utilizzare la flangia B14
* In the P mounting the B5 motor flange can exceed the foot maximum dimensions. Possibly use the flange B14

Motor Flanges Available
Flange Motore Disponibili

B) Supplied with Reduction Bushing
Fornito con Bussola di Riduzione

B) Available on Request without reduction bushing
Disponibile a Richiesta senza Bussola di Riduzione

C) Motor Flange Holes Position
Posizione Fori Flangia Motore

EN Unit **412A** is supplied with synthetic oil for lifetime lubrication, no maintenance is necessary. See table 1 for lubrication and recommended quantity. In table 2 please see possible radial loads and axial loads on the gearbox.

I Il riduttore **412A** viene fornito completo di olio sintetico per la lubrificazione permanente e non necessita di alcuna manutenzione. Vedi tab.1 per oli e quantità consigliati. In tab.2 sono presenti i carichi radiali e assiali applicabili al riduttore.

D Das Getriebe **412A** ist mit synthetischem Öl gefüllt und ist lebensdauergeschmiert. In Tabelle 1 ist die Schmiermenge und das empfohlene Schmiermittel angegeben. In Tabelle 2 sind die zulässigen Radial - und Axialbelastungen des Getriebes aufgeführt.

F Le réducteur **412A** est fourni complet avec de l'huile synthétique pour la lubrification permanente et ne nécessite aucun entretien. Voir tableau 1 concernant les huiles et les quantités conseillées. Les charges radiales et axiales applicables au réducteur sont précisées dans le tableau 2.

E El reductor tamaño **412A** se suministra, lubricado de por vida con aceite sintético y no requieren mantenimiento alguna. Ver tabla 1, para cantidades y aceites recomendados. En la tabla 2, se encuentran las cargas radiales y axiales admitidas por el reductor.

Standard supplied	For these mounting position specify in the order or add oil Per queste posizioni specificare in fase d'ordine o aggiungere olio						
B3	B6	B7	B8	V5	V6	V8	
0.25 LT	0.35 LT	0.40 LT	0.45 LT	0.40 LT	0.50 LT	Ask	
SHELL Omala S4 WE 320				ENI Telium VSF 320			

For all details on lubrication and plugs check our website **tab. 1**
Per maggiori dettagli su lubrificazione e tappi olio vedi il nostro sito web

RADIAL AND AXIAL LOADS									
Output shaft Albero di uscita					$F_{eq} = F_R \cdot \frac{46}{X+21}$				
n ₂	FA	FR	n ₂	FA	FR	n ₂	FA	FR	
300	310	1550	140	406	2030	70	540	2700	
250	330	1650	120	448	2240	40	600	3000	
200	360	1800	85	480	2400	15	600	3000	
Input shaft Albero in entrata									
n ₁	FA	FR							
1400	240	1200							
900	280	1400							
500	340	1700							

tab. 2

P412A **B1** ... With feet
Con piedini

Gearbox weight **5.7 kg**
peso riduttore With flange
With feet **5.9 Kg**

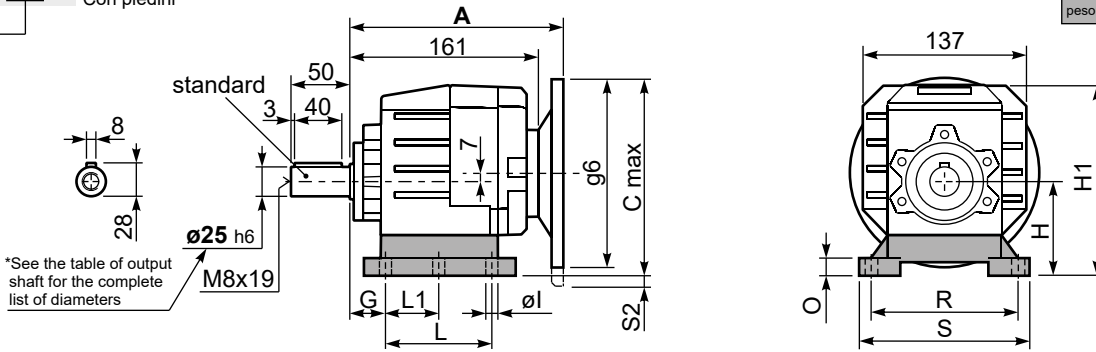

Feet / piedini

Feet Code	Market reference	G	H	R	L	L1	S	H1	O	øl	S2 only with motor flange	B5 max. Flange	kit code
B1	112	18	85	110	87	50	130	167.5	15	-	8/33 80/90B5 100/112B5	-	KC35.9.021
B2	212/3	18	100	130	107.5	60	155	182.5	17	11	18 100/112B5	-	KC40.9.025
S1	17	18	75	110	90±110	50	145	155.5	15	9	18/43 80/90B5 100/112B5	-	KC40.9.022
S2	27	25	90	110	130	-	145	172.5	20	9	3/28 80/90B5 100/112B5	-	KC40.9.024
H2	022-223	25	100	110	115	-	145	182.5	20	9	18 100/112B5	-	KC40.9.026
M1	42/3	25	80	110±120	85	-	145	162.5	15	9	13/38 80/90B5 100/112B5	-	KC40.9.023

Other feet are available, see our web site
Sono disponibili altri piedini, consulta il nostro sito web

A see on page bottom

Most popular types
Tipi più diffusi

P412A **F** ... Output flanges
flange di uscita

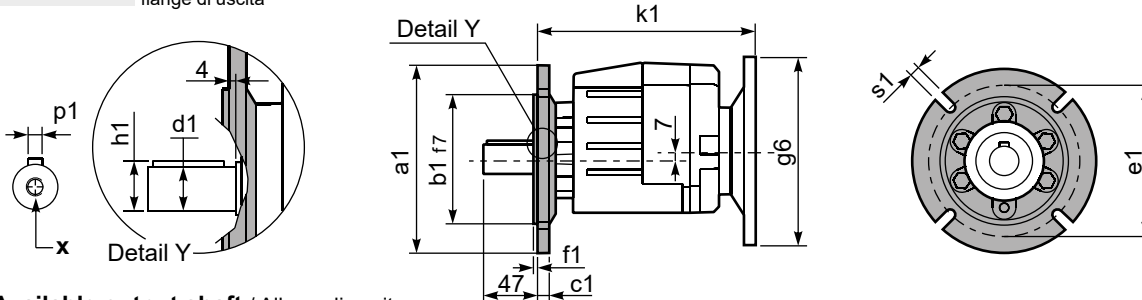

***Available output shaft / Albero di uscita**

	Shaft - d1	p1	h1	x
Standard	ø 25x50	8	28	M8x19
On request A richiesta	ø 16x40	5	18	M6x16
	ø 19x40	6	21.5	M6x16
	ø 20x40	6	22.5	M8x19
	ø 24x50	8	27	M8x19

Available output flanges / flange di uscita

a1 ø	b1	c1	e1	f1	s1	kit code
120	80	10	100	3	7	KC40.9.010
140	95	10	115	3	9	KC40.9.011
160	110	10	130	3.5	9	KC40.9.012
200	130	10	165	3.5	11	KC40.9.013
250	180	11.5	215	3.5	14	KC40.9.014

With flange and feet only on request. Ask for compatibility

P412A **N** ... Basic gearbox
Riduttore base

R412A **N** ... Input Shaft
Albero in entrata

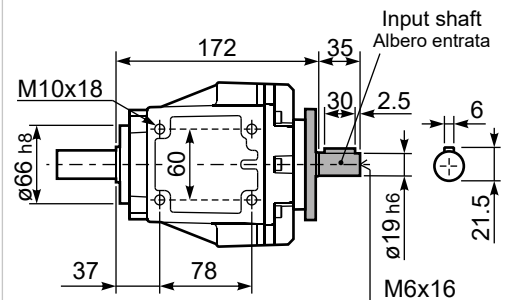
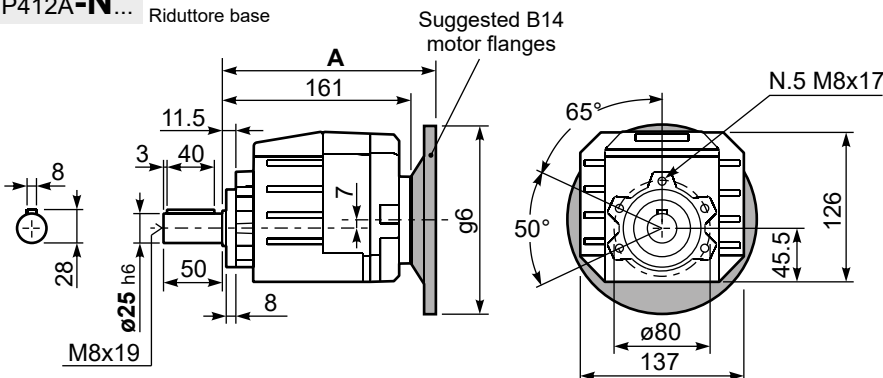

B5 Motor Flanges	A	C _{max}	g6	k1	kit code
63 B5	181.5	177	140	185.5	K063.4.041
71 B5	179.5	187	160	183.5	K063.4.042
80/90 B5	181.5	207	200	185.5	K063.4.043
100/112 B5	196.5	232	250	200.5	KC40.4.043

B14 Motor Flanges	A	C _{max}	g6	k1	kit code
71 B14	179.5	159.5	105	183.5	K063.4.047
80 B14	181.5	167	120	185.5	K063.4.046
90 B14	181.5	177	140	185.5	K063.4.041
100/112 B14	196.5	187	160	200.5	KC40.4.041



QUICK SELECTION / Selezione veloce

input speed (n_1) = 1400 min⁻¹

Output Speed n_2 [min ⁻¹]	Ratio i	Motor power P_{1M} [kW]	Output torque M_{2M} [Nm]	Service factor f.s.	Nominal power P_{1R} [kW]	Nominal torque M_{2R} [Nm]	Available B5 motor flanges		Available B14 motor flanges			Output Shaft \varnothing	Ratios code
							-B	-C	-O	-P	-Q		
							63	71	56	63	71		
36.5	38.40	0.37	91	1.8	0.67	165			C	C		171713	02
32.0	43.69	0.37	104	1.6	0.59	165			C	C		191712	03
27.6	50.64	0.37	120	1.4	0.51	165			C	C		171712	04
26.2	53.36	0.37	127	1.3	0.47	160			C	C		191710	05
22.9	61.21	0.37	145	1.2	0.43	170			C	C		191312	06
22.6	61.85	0.37	147	1.1	0.40	160			C	C		171710	07
19.7	70.95	0.37	168	1.0	0.37	170			C	C		131712	08
19.1	73.43	0.37	174	1.0	0.37	175			C	C		101713	09
18.7	74.77	0.37	177	0.9	0.33	160			C	C		191310	10
16.2	86.66	0.25	139	1.2	0.29	160			C	C		131710	11
14.5	96.85	0.25	155	1.1	0.27	170			C	C		101712	12
13.6	102.89	0.25	165	1.1	0.27	175			C	C		101313	13
11.1	126.40	0.18	155	1.1	0.21	170			C	C		91712	17
10.3	135.69	0.18	166	1.0	0.20	170			C	C		101312	15
8.4	165.74	0.12	131	1.2	0.15	160			C	C		101310	16
7.9	177.09	0.12	140	1.2	0.15	170			C	C		91312	18
6.5	216.31	0.09	136	1.2	0.12	160			C	C		91310	19

The dynamic efficiency is **0.94** for all ratios

Motor Flanges Available
Flange Motore Disponibili

B) Supplied with Reduction Bushing
Fornito con Bussola di Riduzione

B) Available on Request without reduction bushing
Disponibile a Richiesta senza Bussola di Riduzione

C) Motor Flange Holes Position
Posizione Fori Flangia Motore

EN Unit **413A** is supplied with synthetic oil for lifetime lubrication, no maintenance is necessary.
See table 1 for lubrication and recommended quantity.
In table 2 please see possible radial loads and axial loads on the gearbox.

I Il riduttore **413A** viene fornito completo di olio sintetico per la lubrificazione permanente e non necessita di alcuna manutenzione.
Vedi tab.1 per oli e quantità consigliati.
In tab.2 sono presenti i carichi radiali e assiali applicabili al riduttore.

D Das Getriebe **413A** ist mit synthetischem Öl gefüllt und ist lebensdauergeschmiert.
In Tabelle 1 ist die Schmiermenge und das empfohlene Schmiermittel angegeben.
In Tabelle 2 sind die zulässigen Radial - und Axialbelastungen des Getriebes aufgeführt.

F Le réducteur **413A** est fourni complet avec de l'huile synthétique pour la lubrification permanente et ne nécessite aucun entretien.
Voir tableau 1 concernant les huiles et les quantités conseillées.
Les charges radiales et axiales applicables au réducteur sont précisées dans le tableau 2.

E El reductor tamaño **413A** se suministra, lubricado de por vida con aceite sintético y no requieren mantenimiento alguna.
Ver tabla 1, para cantidades y aceites recomendados.
En la tabla 2, se encuentran las cargas radiales y axiales admitidas por el reductor.

Standard supplied	For these mounting position specify in the order or add oil Per queste posizioni specificare in fase d'ordine o aggiungere olio					
0.30 LT	0.35 LT	0.45 LT	0.45 LT	0.45 LT	0.55 LT	Ask
SHELL Omala S4 WE 320			ENI Telium VSF 320			

For all details on lubrication and plugs check our website **tab. 1**
Per maggiori dettagli su lubrificazione e tappi olio vedi il nostro sito web

RADIAL AND AXIAL LOADS									
Output shaft Albero di uscita					$F_{eq} = FR \cdot \frac{46}{X+21}$				
n_2	FA	FR	n_2	FA	FR	n_2	FA	FR	
300	310	1550	140	406	2030	70	540	2700	
250	330	1650	120	448	2240	40	600	3000	
200	360	1800	85	480	2400	15	600	3000	
Input shaft Albero in entrata									
n_1	FA	FR							
1400	140	700							
900	160	800							
500	190	950							

tab. 2

P413A **B1** ... With feet
Con piedini

Gearbox weight **6.1 kg**
peso riduttore With feet **6.3 kg**

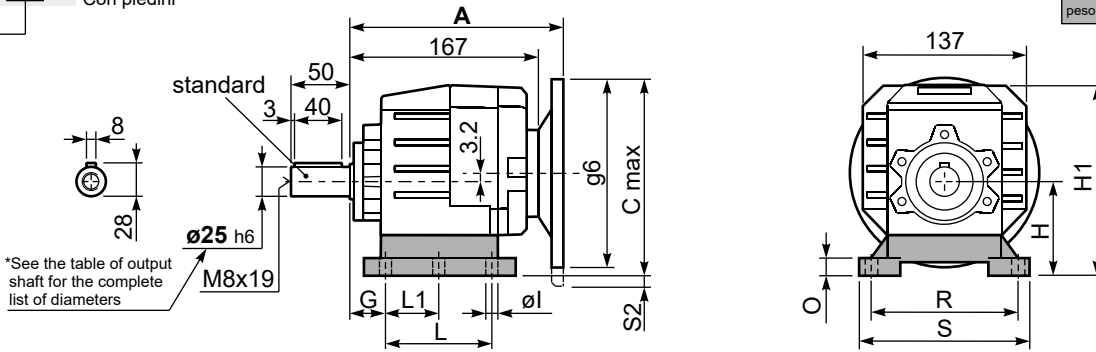

Feet / piedini

Feet Code	Market reference	G	H	R	L	L1	S	H1	O	øl	S2 only with motor flange	B5 max. Flange	kit code
B1	112	18	85	110	87	50	130	167.5	15	-	-	-	KC35.9.021
B2	212/3	18	100	130	107.5	60	155	182.5	17	11	-	-	KC40.9.025
S1	17	18	75	110	90±110	50	145	155.5	15	9	2 80/90B5	-	KC40.9.022
S2	27	25	90	110	130	-	145	172.5	20	9	-	-	KC40.9.024
H2	022-223	25	100	110	115	-	145	182.5	20	9	-	-	KC40.9.026
M1	42/3	25	80	110±120	85	-	145	162.5	15	9	-	-	KC40.9.023

Other feet are available, see our web site
Sono disponibili altri piedini, consulta il nostro sito web

A see on page bottom

Most popular types
Tipi più diffusi

P413A-**F** ... Output flanges
flange di uscita

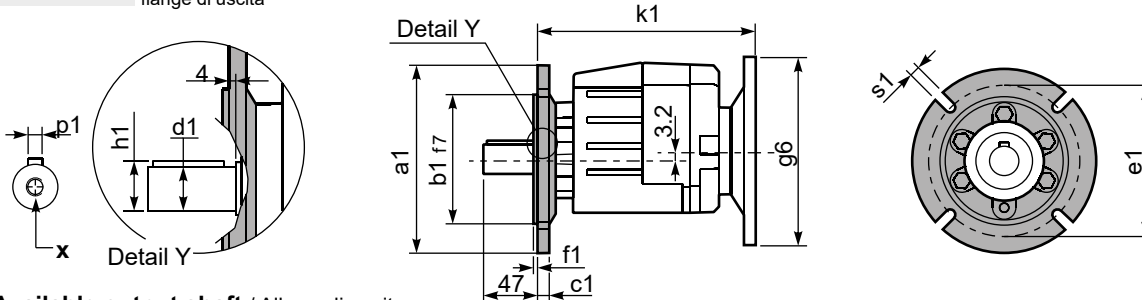

***Available output shaft / Albero di uscita**

	Shaft - d1	p1	h1	x
Standard	ø 25x50	8	28	M8x19
On request A richiesta	ø 16x40	5	18	M6x16
	ø 19x40	6	21.5	M6x16
	ø 20x40	6	22.5	M8x19
	ø 24x50	8	27	M8x19

Available output flanges / flange di uscita

a1 ø	b1	c1	e1	f1	s1	kit code
120	80	10	100	3	7	KC40.9.010
140	95	10	115	3	9	KC40.9.011
160	110	10	130	3.5	9	KC40.9.012
200	130	10	165	3.5	11	KC40.9.013
250	180	11.5	215	3.5	14	KC40.9.014

With flange and feet only on request. Ask for compatibility

P413A-**N** ... Basic gearbox
Riduttore base

Suggested B14 motor flanges

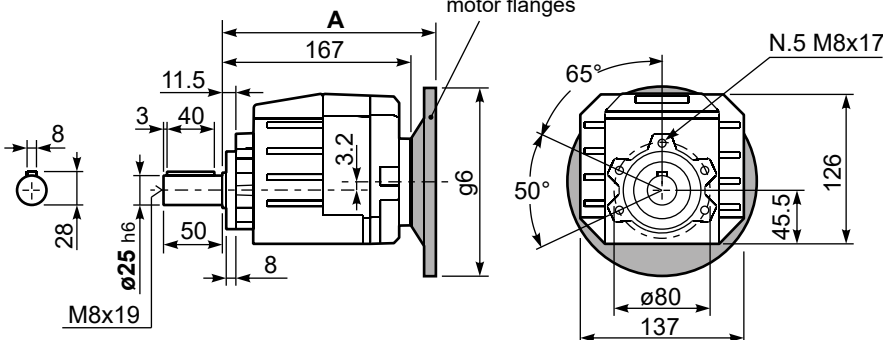

B5 Motor Flanges	A	C _{max}	g6	k1	kit code
63 B5	185.5	173.2	140	189.5	K050.4.041
71 B5	183	183.2	160	187	K050.4.042

R413A-N ... Input Shaft
Albero in entrata

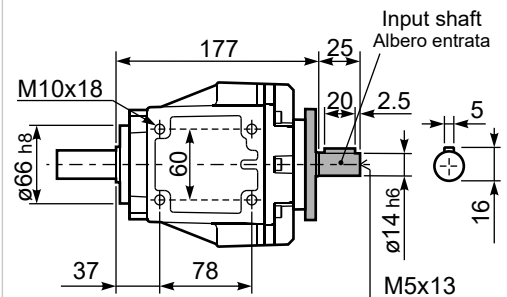

B14 Motor Flanges	A	C _{max}	g6	k1	kit code
56 B14	183	143.2	80	187	KC40.4.049
63 B14	185.5	148.2	90	189.5	K050.4.047
71 B14	183	155.7	105	187	K050.4.045



QUICK SELECTION / Selezione veloce

input speed (n₁) = 1400 min⁻¹

Output Speed n ₂ [min ⁻¹]	Ratio i	Motor power P _{1M} [kW]	Output torque M _{2M} [Nm]	Service factor f.s.	Nominal power P _{1R} [kW]	Nominal torque M _{2R} [Nm]	Available B5 motor flanges					Available B14 motor flanges				Output Shaft	Ratios code
							-C	-D	-E	-F	-G	-R	-T	-U	-V		
							71	80	90	100* 112	132*	80	90	100 112	132		
388	3.61	4	93	1.6	6.3	150	B									3018	01
331	4.23	4	108	1.6	6.1	170	B									3016	02
279	5.01	4	129	1.6	6.1	200	B									3014	03
231	6.07	4	156	1.6	6.3	250	B									3012	04
206	6.81	4	175	1.6	6.2	277	B									2018	05
176	7.96	4	204	1.5	5.8	300	B									2016	06
148	9.45	4	242	1.3	4.9	304	B									2014	07
122	11.43	4	293	1.0	4.0	300	B									2012	08
99	14.21	3	274	1.0	2.8	265	B									2010	09
84	16.62	3	321	0.9	2.8	304	B									1314	10
70	20.10	2.2	286	1.0	2.3	300	B									1312	11
56	24.98	1.85	302	0.9	1.6	265	B									1310	12
47.6	29.41	1.5	288	1.1	1.6	304	B									814	13
39.3	35.58	1.5	349	0.9	1.3	300	B									812	14
34.6	40.50	1.1	290	1.0	1.1	290	B									614	15
31.7	44.23	1.1	316	0.8	0.92	265	B									810	16
28.6	49.00	0.75	240	1.2	0.93	300	B									612	17
23.0	60.90	0.75	299	0.9	0.66	265	B									610	18

The dynamic efficiency is **0.96** for all ratios

*Nel montaggio P la flangia può superare l'ingombro massimo dei piedi. Eventualmente utilizzare la flangia B14

* In the P mounting the B5 motor flange can exceed the foot maximum dimensions. Possibly use the flange B14

Motor Flanges Available
Flange Motore Disponibili

B) Supplied with Reduction Bushing
Fornito con Bussola di Riduzione

B) Available on Request without reduction bushing
Disponibile a Richiesta senza Bussola di Riduzione

C) Motor Flange Holes Position
Posizione Fori Flangia Motore

EN Unit **452A** is supplied with synthetic oil for lifetime lubrication, no maintenance is necessary. See table 1 for lubrication and recommended quantity. In table 2 please see possible radial loads and axial loads on the gearbox.

I Il riduttore **452A** viene fornito completo di olio sintetico per la lubrificazione permanente e non necessita di alcuna manutenzione. Vedi tab.1 per oli e quantità consigliati. In tab.2 sono presenti i carichi radiali e assiali applicabili al riduttore.

D Das Getriebe **452A** ist mit synthetischem Öl gefüllt und ist lebensdauergeschmiert. In Tabelle 1 ist die Schmiermenge und das empfohlene Schmiermittel angegeben. In Tabelle 2 sind die zulässigen Radial- und Axialbelastungen des Getriebes aufgeführt.

F Le réducteur **452A** est fourni complet avec de l'huile synthétique pour la lubrification permanente et ne nécessite aucun entretien. Voir tableau 1 concernant les huiles et les quantités conseillées. Les charges radiales et axiales applicables au réducteur sont précisées dans le tableau 2.

E El reductor tamaño **452A** se suministra, lubricado de por vida con aceite sintético y no requieren mantenimiento alguna. Ver tabla 1, para cantidades y aceites recomendados. En la tabla 2, se encuentran las cargas radiales y axiales admitidas por el reductor.

Standard supplied	For these mounting position specify in the order or add oil					
	Per queste posizioni specificare in fase d'ordine o aggiungere olio					
B3	B6	B7	B8	V5	V6	V8
0.31 LT	0.31 LT	0.31 LT	0.31 LT	0.31 LT	0.31 LT	Ask
SHELL Omala S4 WE 320			AGIP Telium VSF 320			

For all details on lubrication and plugs check our website **tab. 1**
Per maggiori dettagli su lubrificazione e tappi olio vedi il nostro sito web

RADIAL AND AXIAL LOADS											
Output shaft / Albero di uscita					Input shaft / Albero in entrata						
$F_{eq} = FR \cdot \frac{51}{X+21}$											
n ₂	FA	FR	n ₂	FA	FR	n ₂	FA	FR	n ₁	FA	FR
300	415	2070	140	540	2700	70	700	3510	1400	400	2000
250	430	2160	120	560	2790	40	810	4050	900	440	2200
200	470	2340	85	630	3150	15	900	4500	500	440	2200

tab. 2

P452A B1 ... With feet
Con piedini

Gearbox weight With flange **8.7 kg**
peso riduttore With feet **8.9 Kg**

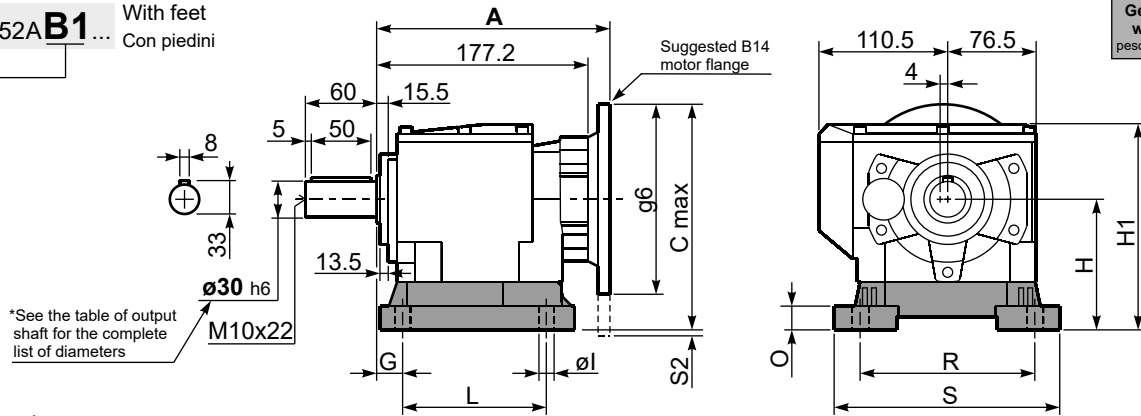

*See the table of output shaft for the complete list of diameters

Feet / piedini

Feet Code	Market reference	G	H	R	L	S	H1	O	øl	S2 only with motor flange	B5 max. Flange	kit code
B3	312/3	18	110	160	130	190	173	20	11	15 100/112B5 40 132B5	-	KC50.9.024
B4	30/35	20	130	180	149.5	216	193	18	14	20 132B5	-	KC60.9.024
S4	47-57	30	115	135	165	170	178	24	13.5	-	80/90B5	KC50.9.022
H3	023-233	30	130	135	135	185	193	25	14	20 132B5	-	KC50.9.025
M2	52/3	30	110	135-150	100	190	173	18	11	15 100/112B5 40 132B5	-	KC50.9.023

Other feet are available, see our web site
Sono disponibili altri piedini, consulta il nostro sito web

A see on page bottom

Most popular types
Tipi più diffusi

P452A-F ... Output flanges
flange di uscita

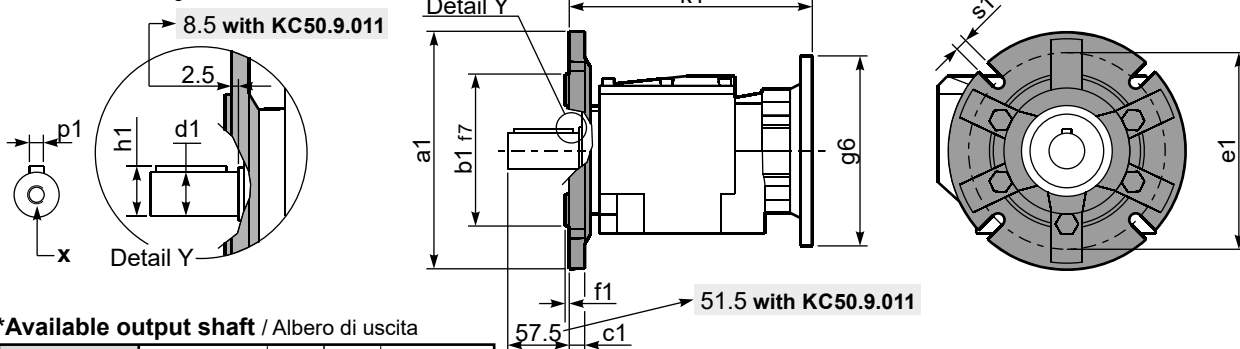

*Available output shaft / Alberi di uscita

	Shaft - d1	p1	h1	x
Standard	ø 30x60	8	33	M10x22
On request A richiesta	ø 24x50	8	27	M8x19
	ø 25x50	8	28	M8x19
	ø 28x60	8	31	M8x19
	ø 35x60	10	38	M10x22

Available output flanges / flange di uscita

a1 ø	b1	c1	e1	f1	s1	kit code
160	110	14	130	3.5	11	KC50.9.011
200	130	13	165	3.5	11	KC50.9.012
250	180	15.5	215	4	14	KC50.9.013

With flange and feet only on request.
Ask for compatibility

P452A-N ... Basic gearbox
Riduttore base

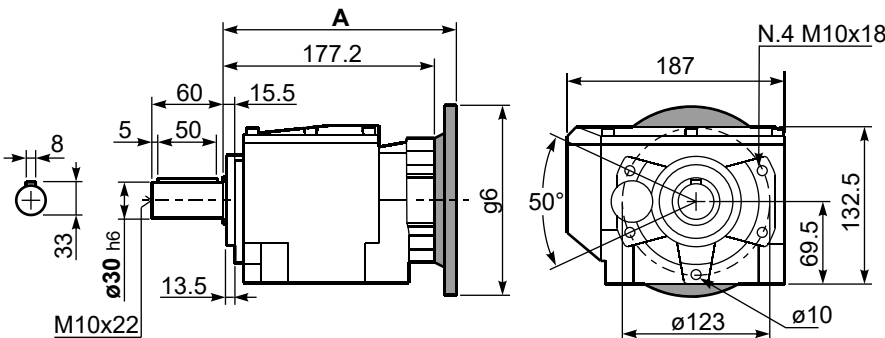

R452A-N ... Input Shaft
Albero in entrata

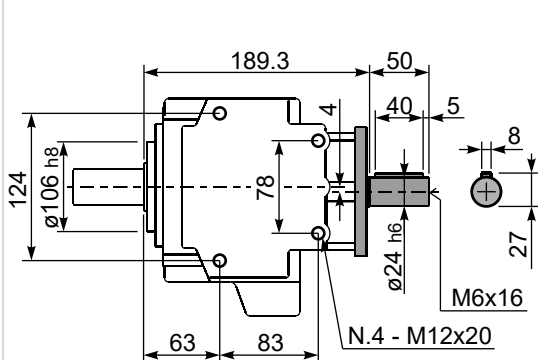

B5 Motor Flanges	A	C _{max}	g6	k1	kit code	k1 with KC50.9.011	B14 Motor Flanges	A	C _{max}	g6	k1	kit code	k1 with KC50.9.011
71 B5	195.7	222	160	198.2	K023.4.041	204.2	80 B14	197.7	202	120	200.2	K085.4.046	206.2
80/90 B5	197.7	242	200	200.2	K023.4.042	206.2	90 B14	197.7	212	140	200.2	K085.4.045	206.2
100/112 B5	206.7	267	250	209.2	K023.4.043	215.2	100/112 B14	206.7	222	160	209.2	K085.4.047	215.2
132 B5	227.7	292	300	227.2	KC51.4.043	233.2	132 B14	227.7	242	200	227.2	KC51.4.041	233.2

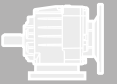

QUICK SELECTION / Selezione veloce

input speed (n_1) = 1400 min⁻¹

Output Speed n_2 [min ⁻¹]	Ratio i	Motor power P_{1M} [kW]	Output torque M_{2M} [Nm]	Service factor f.s.	Nominal power P_{1R} [kW]	Nominal torque M_{2R} [Nm]	Available B5 motor flanges					Available B14 motor flanges				Output Shaft 	Ratios code	
							-C	-D	-E	-F	-G	-R	-T	-U	-V			
							71	80	90	100* 112	132*	80	90	100 112	132			
388	3.61	5.5	127	1.2	6.6	155	B										3018	01
331	4.23	5.5	148	1.2	6.5	180	B										3016	02
279	5.01	5.5	176	1.2	6.4	210	B										3014	03
231	6.07	5.5	213	1.2	6.4	255	B										3012	04
206	6.81	5.5	239	1.3	6.7	300	B										2018	05
176	7.96	5.5	279	1.2	6.4	335	B										2016	07
148	9.45	5.5	331	1.1	5.8	360	B										2014	08
122	11.43	4	293	1.1	4.4	330	B										2012	09
100	14.00	3	270	1.3	3.9	360	B										1316	21
84	16.62	3	321	1.1	3.3	360	B										1314	11
70	20.10	2.2	286	1.2	2.5	330	B										1312	12
57	24.61	2.2	350	0.9	2.0	330	B										1112	20
47.6	29.41	1.5	288	1.2	1.9	360	B										814	14
39.3	35.58	1.5	349	0.9	1.4	330	B										812	15
34.6	40.50	1.1	290	1.1	1.2	320	B										614	16
31.7	44.23	1.1	316	0.8	0.88	255	B										810	17
28.6	49.00	1.1	351	0.9	1.0	330	B										612	18
23.0	60.90	0.75	299	0.8	0.64	255	B										610	19

The dynamic efficiency is **0.96** for all ratios

*Nel montaggio P la flangia può superare l'ingombro massimo dei piedi. Eventualmente utilizzare la flangia B14
* In the P mounting the B5 motor flange can exceed the foot maximum dimensions. Possibly use the flange B14

- Motor Flanges Available**
Flange Motore Disponibili
- B) Supplied with Reduction Bushing**
Fornito con Bussola di Riduzione
- B) Available on Request without reduction bushing**
Disponibile a Richiesta senza Bussola di Riduzione
- C) Motor Flange Holes Position**
Posizione Fori Flangia Motore

EN Unit **512A** is supplied with synthetic oil for lifetime lubrication, no maintenance is necessary. See table 1 for lubrication and recommended quantity. In table 2 please see possible radial loads and axial loads on the gearbox.

I Il riduttore **512A** viene fornito completo di olio sintetico per la lubrificazione permanente e non necessita di alcuna manutenzione. Vedi tab.1 per oli e quantità consigliati. In tab.2 sono presenti i carichi radiali e assiali applicabili al riduttore.

D Das Getriebe **512A** ist mit synthetischem Öl gefüllt und ist lebensdauergeschmiert. In Tabelle 1 ist die Schmiermenge und das empfohlene Schmiermittel angegeben. In Tabelle 2 sind die zulässigen Radial - und Axialbelastungen des Getriebes aufgeführt.

F Le réducteur **512A** est fourni complet avec de l'huile synthétique pour la lubrification permanente et ne nécessite aucun entretien. Voir tableau 1 concernant les huiles et les quantités conseillées. Les charges radiales et axiales applicables au réducteur sont précisées dans le tableau 2.

E El reductor tamaño **512A** se suministra, lubricado de por vida con aceite sintético y no requieren mantenimiento alguna. Ver tabla 1, para cantidades y aceites recomendados. En la tabla 2, se encuentran las cargas radiales y axiales admitidas por el reductor.

Standard supplied	For these mounting position specify in the order or add oil Per queste posizioni specificare in fase d'ordine o aggiungere olio					
0.70 LT	0.80 LT	1.15 LT	1.20 LT	1.15 LT	1.25 LT	Ask
SHELL Omala S4 WE 320				ENI Telium VSF 320		

For all details on lubrication and plugs check our website **tab. 1**
Per maggiori dettagli su lubrificazione e tappi olio vedi il nostro sito web

RADIAL AND AXIAL LOADS

Output shaft
Albero di uscita

$F_{eq} = F_R \cdot \frac{54}{X+24}$

n_2	FA	FR	n_2	FA	FR	n_2	FA	FR
300	460	2300	140	600	3000	70	780	3900
250	480	2400	120	620	3100	40	900	4500
200	520	2600	85	700	3500	15	1000	5000

Input shaft
Albero in entrata

n_1	FA	FR
1400	450	2250
900	500	2500
500	600	3000

tab. 2

P512A **B1** ... With feet
Con piedini

Gearbox weight **11.7 kg**
peso riduttore With feet **11.9 Kg**

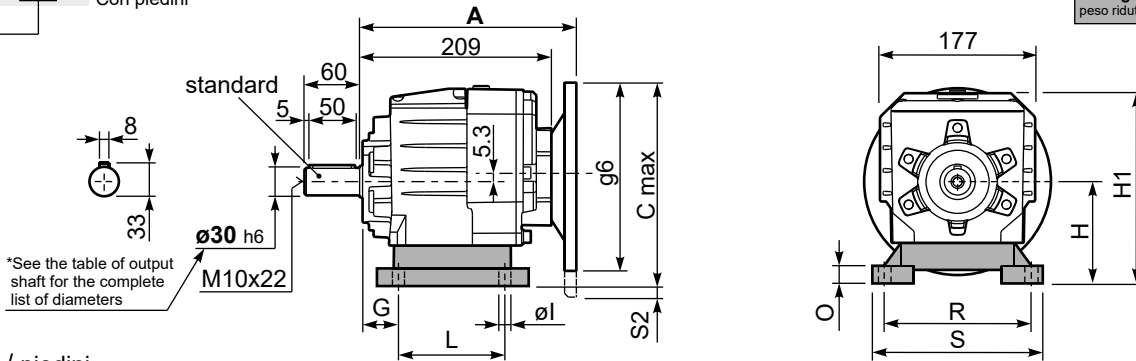

Feet / piedini

Feet Code	Market reference	G	H	R	L	S	H1	O	øl	S2 only with motor flange	B5 max. Flange	kit code
B3	312/3	18	110	160	130	190	211	20	11	10 100/112B5 35 132B5	-	KC50.9.024
B4	30/35	20	130	180	149.5	216	231	18	14	15 132B5	-	KC60.9.024
S4	47-57	30	115	135	165	170	216	25	14	5 100/112B5 30 132B5	-	KC50.9.022
H3	023-233	30	130	135	135	185	231	25	14	15 132B5	-	KC50.9.025
M2	52/3	30	110	135-150	100	190	211	18	11	10 100/112B5 35 132B5	-	KC50.9.023

Other feet are available, see our web site
Sono disponibili altri piedini, consulta il nostro sito web

A see on page bottom

Most popular types
Tipi più diffusi

P512A-**F** ... Output flanges
flange di uscita

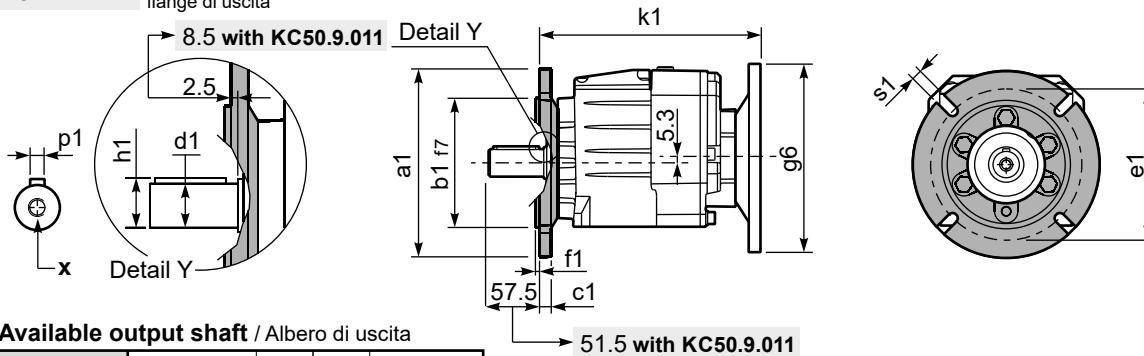

*Available output shaft / Alberi di uscita

	Shaft - d1	p1	h1	x
Standard	ø 30x60	8	33	M10x22
On request A richiesta	ø 24x50	8	27	M8x19
	ø 25x50	8	28	M8x19
	ø 28x60	8	31	M8x19
	ø 35x60	10	38	M10x22

Available output flanges / flange di uscita

a1 ø	b1	c1	e1	f1	s1	kit code
160	110	14	130	3.5	11	KC50.9.011
200	130	13	165	3.5	11	KC50.9.012
250	180	15.5	215	4	14	KC50.9.013

With flange and feet only on request.
Ask for compatibility

P512A-**N** ... Basic gearbox
Riduttore base

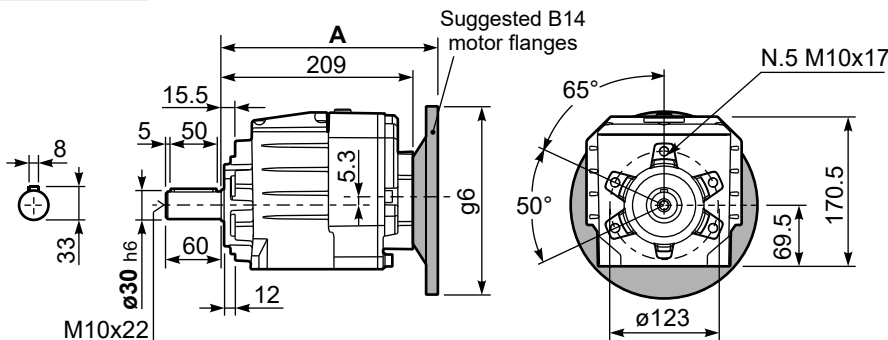

R512A-N ... Input Shaft
Albero in entrata

B5 Motor Flanges	A	C _{max}	g6	k1	kit code	k1 with KC50.9.011	B14 Motor Flanges	A	C _{max}	g6	k1	kit code	k1 with KC50.9.011
71 B5	227.5	215.3	160	230	K023.4.041	236	80 B14	229.5	195.3	120	232	K085.4.046	238
80/90 B5	229.5	235.3	200	232	K023.4.042	238	90 B14	229.5	205.3	140	232	K085.4.045	238
100/112 B5	238.5	260.3	250	241	K023.4.043	247	100/112 B14	238.5	215.3	160	241	K085.4.047	247
132 B5	259.5	285.3	300	259	KC51.4.043	265	132 B14	259.5	235.3	200	259	KC51.4.041	265



QUICK SELECTION / Selezione veloce input speed (n₁) = 1400 min⁻¹

Output Speed n ₂ [min ⁻¹]	Ratio i	Motor power P _{1M} [kW]	Output torque M _{2M} [Nm]	Service factor f.s.	Nominal power P _{1R} [kW]	Nominal torque M _{2R} [Nm]	Available B5 motor flanges				Available B14 motor flanges			Output Shaft 	Ratios code
							-B	-C	-D	-E	-Q	-R	-T		
							63	71	80	90	71	80	90		
35.2	39.79	1.5	382	0.9	1.4	360	B				C	C		191316	01
29.6	47.22	1.1	331	1.1	1.2	360	B				C	C		191314	02
25.6	54.73	1.1	384	0.9	1.0	360	B				C	C		171314	03
21.1	66.22	0.75	318	1.0	0.78	330	B				C	C		171312	04
18.3	76.69	0.75	369	1.0	0.73	360	B				C	C		131314	05
16.7	83.59	0.55	297	1.2	0.67	360	B				C	C		190814	06
15.1	92.78	0.55	329	1.0	0.55	330	B				C	C		131312	07
13.4	104.68	0.55	371	1.0	0.54	360	B				C	C		101314	08
11.9	117.22	0.37	278	1.2	0.44	330	B				C	C		170812	09
11.1	126.65	0.37	300	1.1	0.41	330	B				C	C		101312	10
10.2	136.62	0.37	324	1.1	0.41	360	B				C	C		91314	11
8.5	165.29	0.25	264	1.2	0.31	330	B				C	C		91312	12
7.8	180.40	0.25	289	1.2	0.31	360	B				C	C		71314	13
6.4	218.26	0.25	349	0.9	0.24	330	B				C	C		71312	14
5.8	241.82	0.25	387	0.9	0.23	360	B				C	C		90814	15
4.8	292.57	0.18	358	0.9	0.18	330	B				C	C		90812	16
4.4	319.32	0.18	391	0.9	0.18	360	B				C	C		70814	17
3.6	386.33	0.12	305	1.1	0.13	330	B				C	C		70812	18
2.9	480.16	0.12	380	0.7	0.08	255	B				C	C		70810	19

The dynamic efficiency is **0.94** for all ratios

 Motor Flanges Available Flange Motore Disponibili
 B) Supplied with Reduction Bushing Fornito con Bussola di Riduzione
 B) Available on Request without reduction bushing Disponibile a Richiesta senza Bussola di Riduzione
 C) Motor Flange Holes Position Posizione Fori Flangia Motore

EN Unit **513A** is supplied with synthetic oil for lifetime lubrication, no maintenance is necessary. See table 1 for lubrication and recommended quantity. In table 2 please see possible radial loads and axial loads on the gearbox.

I Il riduttore **513A** viene fornito completo di olio sintetico per la lubrificazione permanente e non necessita di alcuna manutenzione. Vedi tab.1 per oli e quantità consigliati. In tab.2 sono presenti i carichi radiali e assiali applicabili al riduttore.

D Das Getriebe **513A** ist mit synthetischem Öl gefüllt und ist lebensdauergeschmiert. In Tabelle 1 ist die Schmiermenge und das empfohlene Schmiermittel angegeben. In Tabelle 2 sind die zulässigen Radial - und Axialbelastungen des Getriebes aufgeführt.

F Le réducteur **513A** est fourni complet avec de l'huile synthétique pour la lubrification permanente et ne nécessite aucun entretien. Voir tableau 1 concernant les huiles et les quantités conseillées. Les charges radiales et axiales applicables au réducteur sont précisées dans le tableau 2.

E El reductor tamaño **513A** se suministra, lubricado de por vida con aceite sintético y no requieren mantenimiento alguna. Ver tabla 1, para cantidades y aceites recomendados. En la tabla 2, se encuentran las cargas radiales y axiales admitidas por el reductor.

Standard supplied	For these mounting position specify in the order or add oil Per queste posizioni specificare in fase d'ordine o aggiungere olio						
1.00 LT	0.90 LT	1.25 LT	1.15 LT	1.45 LT	1.40 LT	Ask	Ask
SHELL Omala S4 WE 320				ENI Telium VSF 320			

For all details on lubrication and plugs check our website **tab. 1**
Per maggiori dettagli su lubrificazione e tappi olio vedi il nostro sito web

RADIAL AND AXIAL LOADS											
Output shaft Albero di uscita					$F_{eq} = F_R \cdot \frac{54}{X+24}$						
n ₂	FA	FR	n ₂	FA	FR	n ₂	FA	FR	n ₂	FA	FR
300	460	2300	140	600	3000	70	780	3900			
250	480	2400	120	620	3100	40	900	4500			
200	520	2600	85	700	3500	15	1000	5000			
Input shaft Albero di entrata											
n ₁	FA	FR									
1400	400	2000									
900	440	2200									
500	440	2200									

tab. 2

P513A **B1** ... With feet
Con piedini

Gearbox weight With flange **11.9 kg**
peso riduttore With feet **12.1 Kg**

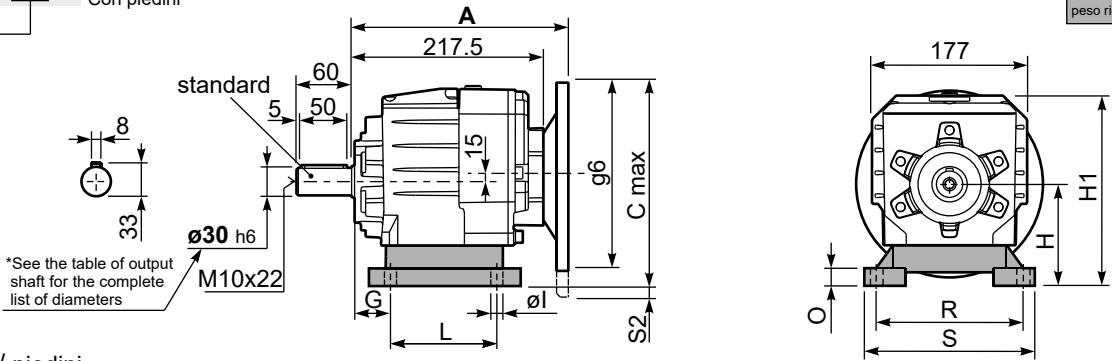

Feet / piedini

Feet Code	Market reference	G	H	R	L	S	H1	O	øl	S2 only with motor flange	B5 max. Flange	kit code
B3	312/3	18	110	160	130	190	211	20	11	-	-	KC50.9.024
B4	30/35	20	130	180	149.5	216	231	18	14	-	-	KC60.9.024
S4	47-57	30	115	135	165	170	216	25	14	-	-	KC50.9.022
H3	023-233	30	130	135	135	185	231	25	14	-	-	KC50.9.025
M2	52/3	30	110	135-150	100	190	211	18	11	-	-	KC50.9.023

Other feet are available, see our web site
Sono disponibili altri piedini, consulta il nostro sito web

A see on page bottom
Most popular types
Tipi più diffusi

P513A-**F** ... Output flanges
flange di uscita

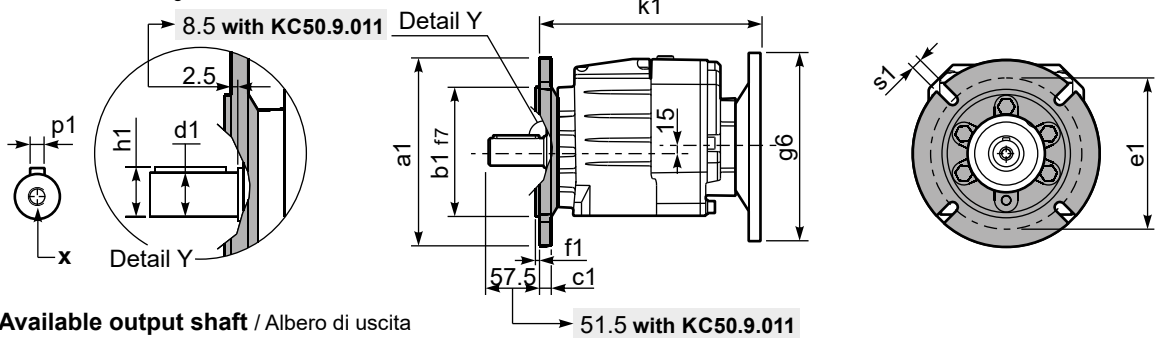

*Available output shaft / Alberi di uscita

	Shaft - d1	p1	h1	x
Standard	ø 30x60	8	33	M10x22
On request A richiesta	ø 24x50	8	27	M8x19
	ø 25x50	8	28	M8x19
	ø 28x60	8	31	M8x19
	ø 35x60	10	38	M10x22

Available output flanges / flange di uscita

a1 ø	b1	c1	e1	f1	s1	kit code
160	110	14	130	3.5	11	KC50.9.011
200	130	13	165	3.5	11	KC50.9.012
250	180	15.5	215	4	14	KC50.9.013

With flange and feet only on request. Ask for compatibility

P513A-**N** ... Basic gearbox
Riduttore base

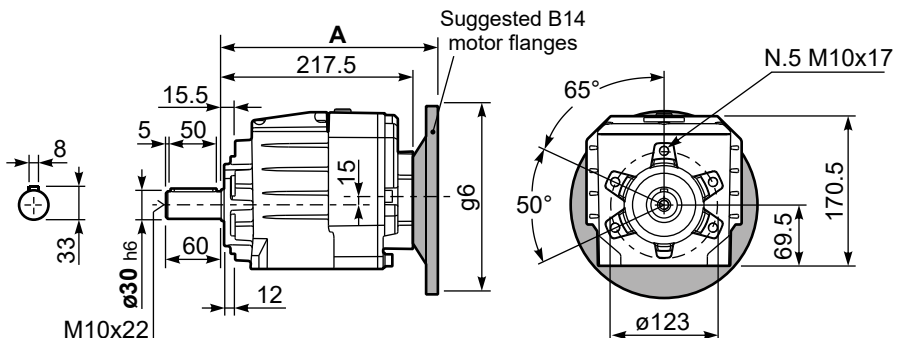

R513A-N ... Input Shaft
Albero in entrata

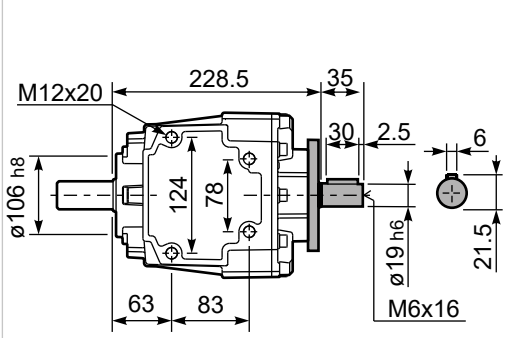

B5 Motor Flanges	A	C _{max}	g6	k1	kit code	k1 with KC50.9.011
63 B5	238	215	140	240.5	K063.4.041	246.5
71 B5	236	225	160	238.5	K063.4.042	244.5
80/90 B5	238	245	200	240.5	K063.4.043	246.5

B14 Motor Flanges	A	C _{max}	g6	k1	kit code	k1 with KC50.9.011
71 B14	236	197.5	105	238.5	K063.4.047	244.5
80 B14	238	205	120	240.5	K063.4.046	246.5
90 B14	238	215	140	240.5	K063.4.041	246.5



QUICK SELECTION / Selezione veloce

input speed (n₁) = 1400 min⁻¹

Output Speed n ₂ [min ⁻¹]	Ratio i	Motor power P _{1M} [kW]	Output torque M _{2M} [Nm]	Service factor f.s.	Nominal power P _{1R} [kW]	Nominal torque M _{2R} [Nm]	Available B5 motor flanges					Available B14 motor flanges				Output Shaft			
							-C	-D	-E	-F	-G	-R	-T	-U	-V			Ratios code	
							71	80	90	100 112	132*	80	90	100 112	132				
388	3.61	7.5	171	1.1	8.0	190	B										3018		01
331	4.23	7.5	200	1.1	8.3	230	B										3016		02
279	5.01	7.5	238	1.1	7.9	260	B										3014		03
231	6.07	7.5	288	1.1	7.8	310	B										3012		04
206	6.81	7.5	323	1.1	7.9	350	B										2018		05
176	7.96	7.5	378	1.0	7.1	370	B										2016		07
148	9.45	5.5	331	1.2	6.6	410	B										2014	standard 	08
122	11.43	5.5	401	1.1	5.7	425	B										2012		09
100	14.00	4	359	1.2	4.7	435	B										1316		10
84	16.62	4	426	1.2	4.7	515	B										1314		11
70	20.10	4	515	1.0	4.0	530	B										1312		12
57	24.61	3	475	1.1	3.3	530	B										1112		20
47.6	29.41	2.2	418	1.1	2.3	450	B										814		14
39.3	35.58	2.2	506	1.0	2.3	530	B										812	On request	15
34.6	40.50	1.1	290	1.1	1.2	320	B										614		16
31.7	44.23	1.5	433	0.9	1.4	410	B										810		17
28.6	49.00	1.1	351	1.1	1.2	400	B										612		18
23.0	60.90	1.1	436	0.9	1.0	410	B										610		19

The dynamic efficiency is **0.96** for all ratios

*Nel montaggio P la flangia può superare l'ingombro massimo dei piedi. Eventualmente utilizzare la flangia B14
* In the P mounting the B5 motor flange can exceed the foot maximum dimensions. Possibly use the flange B14

Motor Flanges Available
Flange Motore Disponibili

B) Supplied with Reduction Bushing
Fornito con Bussola di Riduzione

B) Available on Request without reduction bushing
Disponibile a Richiesta senza Bussola di Riduzione

C) Motor Flange Holes Position
Posizione Fori Flangia Motore

EN Unit **612A** is supplied with synthetic oil for lifetime lubrication, no maintenance is necessary.
See table 1 for lubrication and recommended quantity.
In table 2 please see possible radial loads and axial loads on the gearbox.

I Il riduttore **612A** viene fornito completo di olio sintetico per la lubrificazione permanente e non necessita di alcuna manutenzione.
Vedi tab.1 per oli e quantità consigliati.
In tab.2 sono presenti i carichi radiali e assiali applicabili al riduttore.

D Das Getriebe **612A** ist mit synthetischem Öl gefüllt und ist lebensdauergeschmiert.
In Tabelle 1 ist die Schmiermenge und das empfohlene Schmiermittel angegeben.
In Tabelle 2 sind die zulässigen Radial- und Axialbelastungen des Getriebes aufgeführt.

F Le réducteur **612A** est fourni complet avec de l'huile synthétique pour la lubrification permanente et ne nécessite aucun entretien.
Voir tableau 1 concernant les huiles et les quantités conseillées.
Les charges radiales et axiales applicables au réducteur sont précisées dans le tableau 2.

E El reductor tamaño **612A** se suministra, lubricado de por vida con aceite sintético y no requieren mantenimiento alguna.
Ver tabla 1, para cantidades y aceites recomendados.
En la tabla 2, se encuentran las cargas radiales y axiales admitidas por el reductor.

Standard supplied	For these mounting position specify in the order or add oil					
	Per queste posizioni specificare in fase d'ordine o aggiungere olio					
0.80 LT	1.00 LT	1.20 LT	1.20 LT	1.30 LT	1.35 LT	Ask
SHELL Omala S4 WE 320			ENI Telium VSF 320			

For all details on lubrication and plugs check our website **tab. 1**
Per maggiori dettagli su lubrificazione e tappi olio vedi il nostro sito web

RADIAL AND AXIAL LOADS

Output shaft
Albero di uscita

$F_{eq} = F_R \cdot \frac{60.5}{X+25.5}$

$F_R (N)$
 $F_A (N)$

$F_{eq} (N)$

n ₂	FA	FR	n ₂	FA	FR	n ₂	FA	FR
300	560	2800	140	740	3700	70	890	4200
250	600	3000	120	760	3800	40	1160	5800
200	640	3200	85	840	4000	15	1300	6500

Input shaft
Albero in entrata

$F_R (N)$
 $F_A (N)$

n ₁	FA	FR
1400	450	2250
900	500	2500
500	600	3000

tab. 2

P612A **B1** ... With feet
Con piedini

Gearbox weight **14.1 kg**
peso riduttore With feet **14.5 kg**

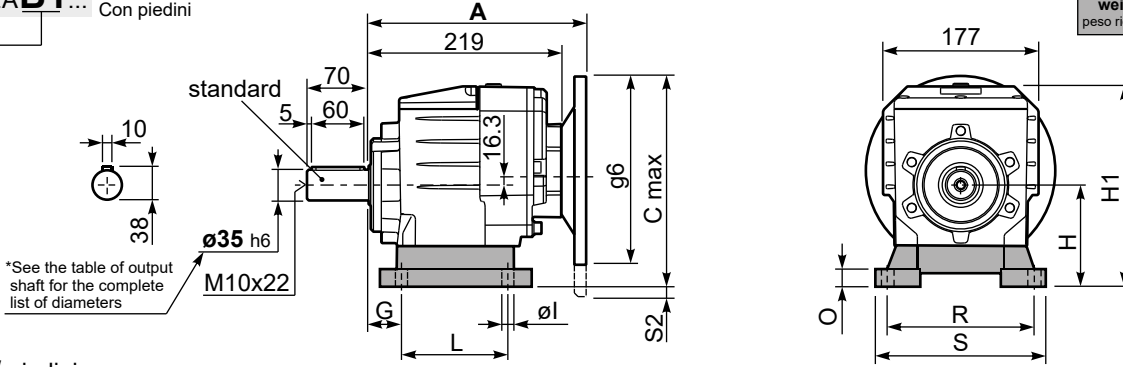

Feet / piedini

Feet Code	Market reference	G	H	R	L	S	H1	O	øl	S2 only with motor flange	B5 max. Flange	kit code
B4	412/3	20	130	180	149.5	216	242	18	14	-	-	KC60.9.024
S4	47-57	30	115	135	165	170	227	25	14	13 132B5	-	KC50.9.022
M3	62/3	35	120	170-185	110	230	232	20	14	8 132B5	-	KC60.9.023
S7	77	35	140	170	205	204	252	8	14	-	-	KC60.9.029LM
H4	024-243	35	155	170	150	225	267	30	14	-	-	KC60.9.025

Other feet are available, see our web site
Sono disponibili altri piedini, consulta il nostro sito web

A see on page bottom

Most popular types
Tipi più diffusi

P612A-**F** ... Output flanges
flange di uscita

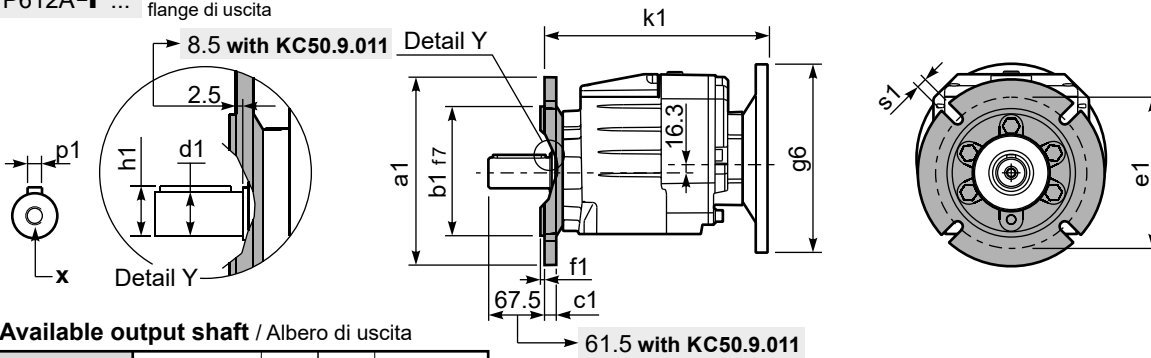

*Available output shaft / Alberi di uscita

	Shaft - d1	p1	h1	x
Standard	ø 35x70	10	38	M10x22
On request A richiesta	ø 28x60	8	31	M8x20
	ø 30x60	8	33	M10x22
	ø 38x70	10	41	M10x25
	ø 40x80	12	43	M12x28

Available output flanges / flange di uscita

a1 ø	b1	c1	e1	f1	s1	kit code
160	110	14	130	3.5	11	KC50.9.011
200	130	13	165	3.5	11	KC50.9.012
250	180	15.5	215	4	14	KC50.9.013

With flange and feet only on request.
Ask for compatibility

P612A-**N** ... Basic gearbox
Riduttore base

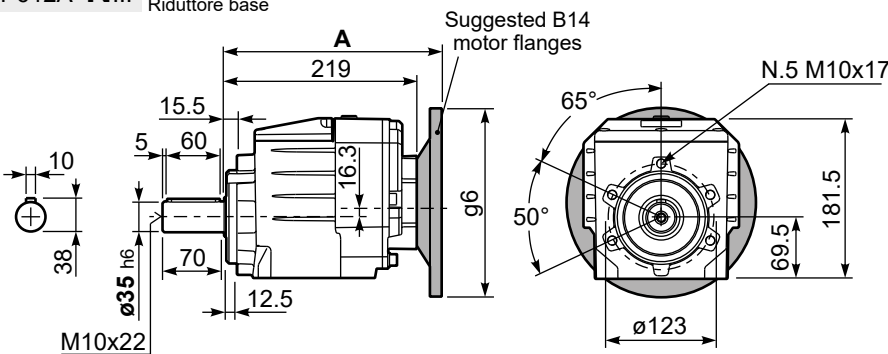

R612A-N ... Input Shaft
Albero in entrata

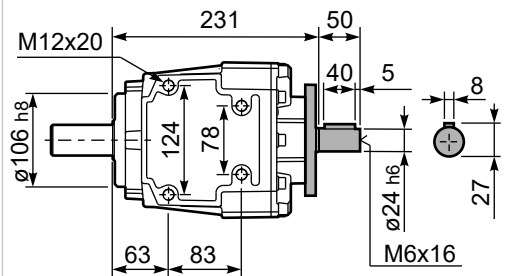

B5 Motor Flanges	A	C _{max}	g6	k1	kit code	k1 with KC50.9.011	B14 Motor Flanges	A	C _{max}	g6	k1	kit code	k1 with KC50.9.011
71 B5	237.5	251.3	160	240	K023.4.041	246	80 B14	239.5	231.3	120	242	K085.4.046	248
80/90 B5	239.5	271.3	200	242	K023.4.042	248	90 B14	239.5	241.3	140	242	K085.4.045	248
100/112 B5	248.5	296.3	250	251	K023.4.043	257	100/112 B14	248.5	251.3	160	251	K085.4.047	257
132 B5	269.5	321.3	300	269	KC51.4.043	275	132 B14	269.5	271.3	200	269	KC51.4.041	275



QUICK SELECTION / Selezione veloce

input speed (n₁) = 1400 min⁻¹

Output Speed n ₂ [min ⁻¹]	Ratio i	Motor power P _{1M} [kW]	Output torque M _{2M} [Nm]	Service factor f.s.	Nominal power P _{1R} [kW]	Nominal torque M _{2R} [Nm]	Available B5 motor flanges				Available B14 motor flanges			Output Shaft 	Ratios code
							-B	-C	-D	-E	-Q	-R	-T		
							63	71	80	90	71	80	90		
35.2	39.79	1.5	382	1.1	1.7	434	B				C	C		191316	05
29.6	47.22	1.5	453	1.1	1.7	515	B				C	C		191314	06
25.6	54.73	1.5	525	1.0	1.5	515	B				C	C		171314	07
24.5	57.13	1.5	548	1.0	1.4	530	B				C	C		191312	08
21.1	66.22	1.1	464	1.1	1.2	530	B				C	C		171312	09
19.7	71.01	1.1	498	0.9	0.96	435	B				C	C		191310	10
18.3	76.69	1.1	538	1.0	1.0	515	B				C	C		131314	11
17.0	82.30	0.75	396	1.1	0.82	435	B				C	C		171310	12
16.7	83.59	0.75	402	1.1	0.82	440	B				C	C		190814	13
15.1	92.78	0.75	446	1.2	0.89	530	B				C	C		131312	14
13.4	104.68	0.75	503	1.0	0.77	515	B				C	C		101314	15
11.9	117.22	0.75	564	0.9	0.71	530	B				C	C		170812	16
11.1	126.65	0.55	449	1.2	0.65	530	B				C	C		101312	17
10.3	135.74	0.55	482	0.9	0.51	440	B				C	C		130814	18
9.6	145.68	0.37	346	1.3	0.47	435	B				C	C		170810	19
8.9	157.40	0.37	373	1.2	0.43	435	B				C	C		101310	20
8.5	165.29	0.37	392	1.3	0.50	525	B				C	C		91312	21
7.6	185.29	0.37	439	1.0	0.37	440	B				C	C		100814	22
6.8	205.43	0.37	487	0.9	0.33	435	B				C	C		91310	23
6.2	224.18	0.37	532	1.0	0.37	530	B				C	C		100812	24
5.8	241.82	0.25	387	1.1	0.28	440	B				C	C		90814	25
5.0	278.62	0.25	446	1.0	0.24	435	B				C	C		100810	26
4.8	292.57	0.25	468	1.1	0.28	530	B				C	C		90812	27
3.9	363.63	0.18	445	1.0	0.19	435	B				C	C		90810	28

The dynamic efficiency is **0.94** for all ratios

A Motor Flanges Available
Flange Motore Disponibili

B Supplied with Reduction Bushing
Fornito con Bussola di Riduzione

B Available on Request without reduction bushing
Disponibile a Richiesta senza Bussola di Riduzione

C Motor Flange Holes Position
Posizione Fori Flangia Motore

EN Unit **613A** is supplied with synthetic oil for lifetime lubrication, no maintenance is necessary. See table 1 for lubrication and recommended quantity. In table 2 please see possible radial loads and axial loads on the gearbox.

I Il riduttore **613A** viene fornito completo di olio sintetico per la lubrificazione permanente e non necessita di alcuna manutenzione. Vedi tab.1 per oli e quantità consigliati. In tab.2 sono presenti i carichi radiali e assiali applicabili al riduttore.

D Das Getriebe **613A** ist mit synthetischem Öl gefüllt und ist lebensdauergeschmiert. In Tabelle 1 ist die Schmiermenge und das empfohlene Schmiermittel angegeben. In Tabelle 2 sind die zulässigen Radial- und Axialbelastungen des Getriebes aufgeführt.

F Le réducteur **613A** est fourni complet avec de l'huile synthétique pour la lubrification permanente et ne nécessite aucun entretien. Voir tableau 1 concernant les huiles et les quantités conseillées. Les charges radiales et axiales applicables au réducteur sont précisées dans le tableau 2.

E El reductor tamaño **613A** se suministra, lubricado de por vida con aceite sintético y no requieren mantenimiento alguna. Ver tabla 1, para cantidades y aceites recomendados. En la tabla 2, se encuentran las cargas radiales y axiales admitidas por el reductor.

Standard supplied	For these mounting position specify in the order or add oil Per queste posizioni specificare in fase d'ordine o aggiungere olio					
1.05 LT	1.10 LT	1.25 LT	1.25 LT	1.35 LT	1.50 LT	Ask
SHELL Omala S4 WE 320				ENI Telium VSF 320		

For all details on lubrication and plugs check our website **tab. 1**
Per maggiori dettagli su lubrificazione e tappi olio vedi il nostro sito web

RADIAL AND AXIAL LOADS								
Output shaft Albero di uscita			$F_{eq} = F_R \cdot \frac{60.5}{X+25.5}$					
n ₂	FA	FR	n ₂	FA	FR	n ₂	FA	FR
300	560	2800	140	740	3700	70	890	4200
250	600	3000	120	760	3800	40	1160	5800
200	640	3200	85	840	4000	15	1300	6500
Input shaft Albero in entrata								
n ₁	FA	FR						
1400	400	2000						
900	440	2200						
500	440	2200						

tab. 2

P613A **B1** ... With feet
Con piedini

Gearbox weight With flange **14.3 kg**
peso riduttore With feet **14.7 Kg**

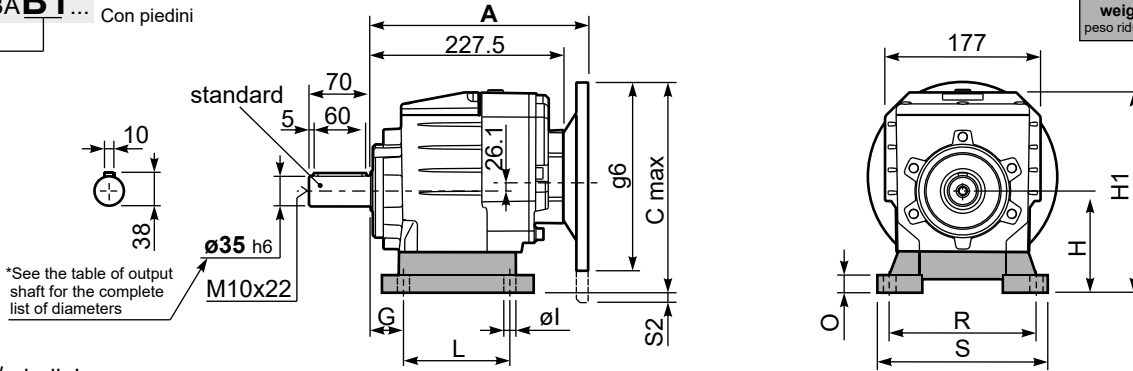

Feet / piedini

Feet Code	Market reference	G	H	R	L	S	H1	O	øl	S2 only with motor flange	B5 max. Flange	kit code
B4	412/3	20	130	180	149.5	216	242	18	14	-	-	KC60.9.024
S4	47-57	30	115	135	165	170	227	25	14	13 132B5	-	KC50.9.022
M3	62/3	35	120	170-185	110	230	232	20	14	8 132B5	-	KC60.9.023
S7	77	35	140	170	205	204	252	8	14	-	-	KC60.9.029LM
H4	024-243	35	155	170	150	225	267	30	14	-	-	KC60.9.025

Other feet are available, see our web site
Sono disponibili altri piedini, consulta il nostro sito web

A see on page bottom

Most popular types
Tipi più diffusi

P613A-**F** ... Output flanges
flange di uscita

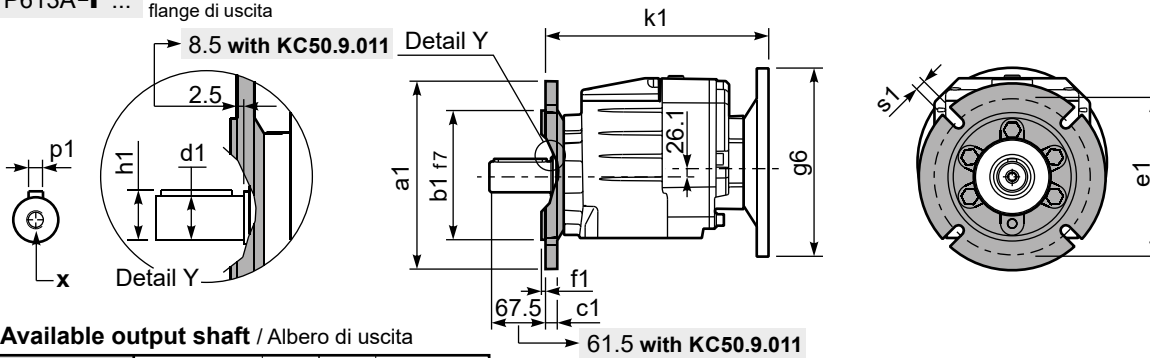

*Available output shaft / Albero di uscita

	Shaft - d1	p1	h1	x
Standard	ø 35x70	10	38	M10x22
On request A richiesta	ø 28x60	8	31	M8x20
	ø 30x60	8	33	M10x22
	ø 38x70	10	41	M10x25
	ø 40x80	12	43	M12x28

Available output flanges / flange di uscita

a1 ø	b1	c1	e1	f1	s1	kit code
160	110	14	130	3.5	11	KC50.9.011
200	130	13	165	3.5	11	KC50.9.012
250	180	15.5	215	4	14	KC50.9.013

With flange and feet only on request.
Ask for compatibility

P613A-**N** ... Basic gearbox
Riduttore base

R613A-N ... Input Shaft
Albero in entrata

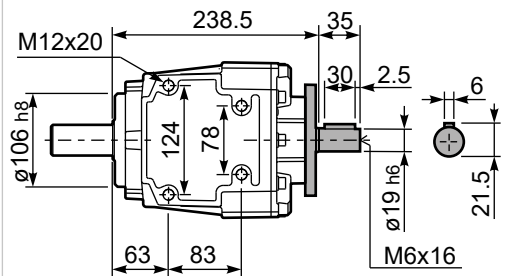
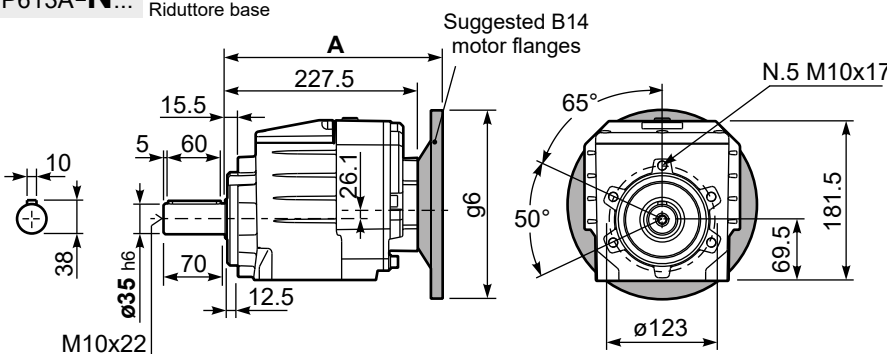

B5 Motor Flanges	A	C _{max}	g6	k1	kit code	k1 with KC50.9.011
63 B5	248	251.1	140	250.5	K063.4.041	256.5
71 B5	246	261.1	160	248.5	K063.4.042	254.5
80/90 B5	248	281.1	200	250.5	K063.4.043	256.5

B14 Motor Flanges	A	C _{max}	g6	k1	kit code	k1 with KC50.9.011
71 B14	246	233.6	105	248.5	K063.4.047	254.5
80 B14	248	241.1	120	250.5	K063.4.046	256.5
90 B14	248	251.1	140	250.5	K063.4.041	256.5

Cast iron in line gearboxes

A modular and compact product

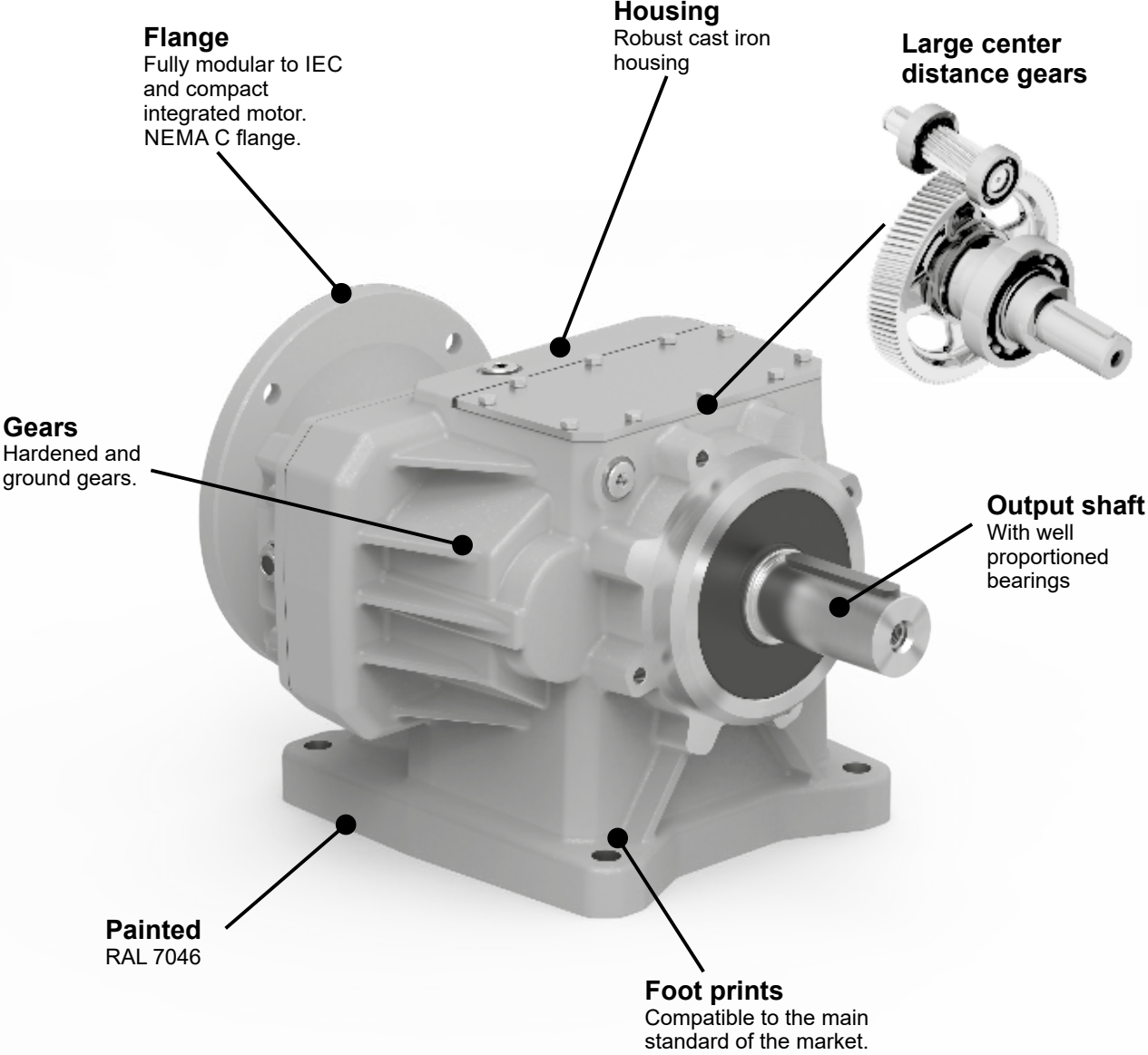

Single-piece Cast Iron housing

with high tensile strength. Precision machined for alignment of bearings and gearing

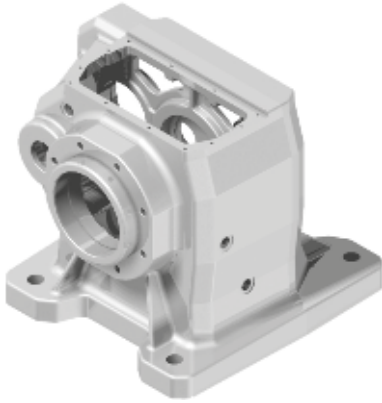

World wide sales network.

Specific type datasheet on page...

On page / A pagina / Auf Seite / À la page / En la página

2 and 3 Stages

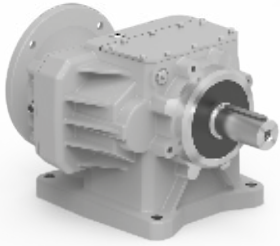

Types / Tipi
Tipen / Types
Tipos

6-5	6-7	6-9	6-11	6-13	6-15	6-17	6-19	6-21	6-23
712C 675Nm	713C 675Nm	812C 900Nm	813C 900Nm	862C 1600Nm	863C 1800Nm	1002 2900Nm	1003 3000Nm	1102 4500Nm	1103 4600Nm

On page / A pagina / Auf Seite / À la page / En la página

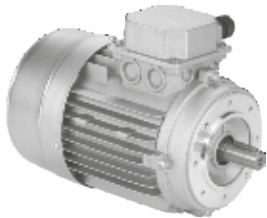

Types / Tipi
Tipen / Types
Tipos

M-1									
56A 56B	63A 63B	71A 71B	80A 80B	90S 90L	100LA 100LB	112M	132S 132M	160M 160L	180M 180L

Type - Tipo - Typ
Type - Tipo

Size - Grandezza - Grösse
Taille - Tamaño

Mounting - Montaggio
Montage - Fixation
Tipo de montaje

Ratio - Rapporto
Untersetzung
Reduction
Relación

P

712C

-F

6.57

Cast iron coaxial gear boxes
Riduttori coassiali in Ghisa

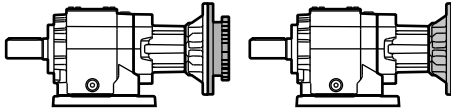

With IEC motor

M

With motor flange

P

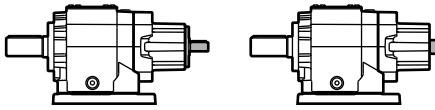

With male input shaft

R

Modular base

B

Not available for:
862C, 1002, 1102,
1003, 1103.

2 Stages
Riduzioni
Stufen
Trains
Etapas

712C
812C
862C
1002
1102

3 Stages
Riduzioni
Stufen
Trains
Etapas

713C
813C
863C
1003
1103

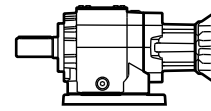

Without flange / feet

-N

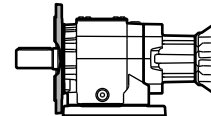

Output flange mounted

-F

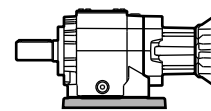

Mounted feet

B..







Feet / piedini

Feet Code	Market reference	G	H	R	L
B1	112	18	85	110	
B2	212/3	18	100	130	
S4	17	18	75	110	
S2	27	25	90		
M1	42/3	25	80		
L4	04	13	80		
L5	05	16	100		

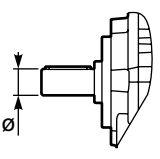
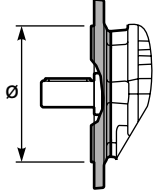
You see feet code in the chart of the dimensions
Vedi codice piede nella tabella delle dimensioni

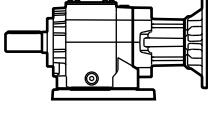
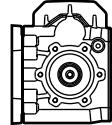
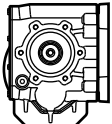
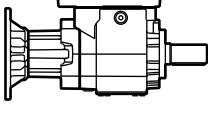
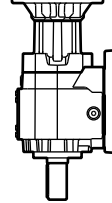
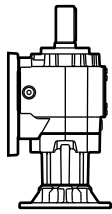
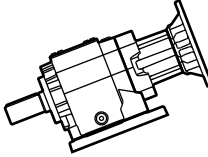
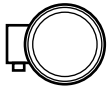
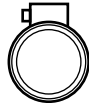
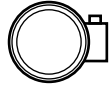

On request we can deliver our products according to the ATEX
A richiesta possiamo fornire i nostri prodotti secondo le normative ATEX
Auf Anfrage können wir unsere Produkte den Richtlinien ATEX entsprechend liefern
Sur demande nos produits peuvent se conformer à la réglementation ATEX
A pedido, se pueden enviar nuestros productos de acuerdo con las normas ATEX.

Output shaft Albero uscita Abtriebswelle Arbre de sortie Eje en salida	Output flange Flangia uscita Ausgangsflansch Bride de sortie Brida en salida	Motor size - Grandezza motore Motor Grösse Grandeur moteur - Tamaño motor	Mounting position Posizione montaggio Einbaulage Position de montage Position de montaje	Input bore Foro entrata Eingangshohlwelle Trou d'entree Eje hueco de entrada	Terminal box position Posizione morsettieria Klemmkastenlage Position boîte à bornes Posición caja de bornes																																													
<p style="text-align: center;">I</p>  <p>→ STANDARD</p> <table border="1" data-bbox="95 660 263 1243"> <tr><td>712C 713C</td></tr> <tr><td>I → ø35</td></tr> <tr><td>L → ø38</td></tr> <tr><td>812C 813C</td></tr> <tr><td>M → ø40</td></tr> <tr><td>N → ø45</td></tr> <tr><td>862C 863C</td></tr> <tr><td>P → ø50</td></tr> <tr><td>J → ø60</td></tr> <tr><td>1002 1003</td></tr> <tr><td>J → ø60</td></tr> <tr><td>1102 1103</td></tr> <tr><td>A → ø70</td></tr> </table>	712C 713C	I → ø35	L → ø38	812C 813C	M → ø40	N → ø45	862C 863C	P → ø50	J → ø60	1002 1003	J → ø60	1102 1103	A → ø70	<p style="text-align: center;">4</p>  <p>→ STANDARD</p> <p>N Senza flangia Without flange</p> <table border="1" data-bbox="311 660 478 1265"> <tr><td>712C 713C</td></tr> <tr><td>4 → ø200</td></tr> <tr><td>5 → ø250</td></tr> <tr><td>812C 813C</td></tr> <tr><td>5 → ø250</td></tr> <tr><td>6 → ø300</td></tr> <tr><td>862C 863C</td></tr> <tr><td>6 → ø300</td></tr> <tr><td>7 → ø350</td></tr> <tr><td>1002 1003</td></tr> <tr><td>6 → ø300</td></tr> <tr><td>7 → ø350</td></tr> <tr><td>8 → ø450</td></tr> <tr><td>1102 1103</td></tr> <tr><td>7 → ø350</td></tr> <tr><td>8 → ø450</td></tr> </table>	712C 713C	4 → ø200	5 → ø250	812C 813C	5 → ø250	6 → ø300	862C 863C	6 → ø300	7 → ø350	1002 1003	6 → ø300	7 → ø350	8 → ø450	1102 1103	7 → ø350	8 → ø450	<p style="text-align: center;">-F</p> <p>Flange Flangia</p>  <p>B5</p> <ul style="list-style-type: none"> -A=56 (ø120) -B=63 (ø140) -C=71 (ø160) -D=80 (ø200) -E=90 (ø200) -F=100+112 (ø250) -G=132 (ø300) -H=160 (ø350) -I=180 (ø350) -L=200 (ø400) CA=225 (ø450) <p>B14</p> <ul style="list-style-type: none"> -O=56 (ø80) -P=63 (ø90) -Q=71 (ø105) -R=80 (ø120) -T=90 (ø140) -U=100+112 (ø160) -V=132 (ø200) <p>Type R Tipo R</p>  <table border="1" data-bbox="726 459 901 784"> <tr><td>713C 813C</td></tr> <tr><td>-2 → ø19</td></tr> <tr><td>712C 812C 863C</td></tr> <tr><td>-3 → ø24</td></tr> <tr><td>862C 1003 1103</td></tr> <tr><td>-4 → ø28</td></tr> <tr><td>1002 1102</td></tr> <tr><td>-6 → ø42</td></tr> </table> <p>Without flange Senza flangia</p>  <p>-M → With coupling</p> <table border="1" data-bbox="726 996 901 1377"> <tr><td>713C 813C</td></tr> <tr><td>-1 → ø14 (71B5)</td></tr> <tr><td>-2 → ø19 (80B5)</td></tr> <tr><td>-3 → ø24 (90B5)</td></tr> <tr><td>712C 812C 863C</td></tr> <tr><td>-2 → ø19 (80B5)</td></tr> <tr><td>-3 → ø24 (90B5)</td></tr> <tr><td>-4 → ø28 (100B5)</td></tr> </table>	713C 813C	-2 → ø19	712C 812C 863C	-3 → ø24	862C 1003 1103	-4 → ø28	1002 1102	-6 → ø42	713C 813C	-1 → ø14 (71B5)	-2 → ø19 (80B5)	-3 → ø24 (90B5)	712C 812C 863C	-2 → ø19 (80B5)	-3 → ø24 (90B5)	-4 → ø28 (100B5)	<p style="text-align: center;">B3</p>  <p>B3 STANDARD</p>  <p>B6</p>  <p>B7</p>  <p>B8</p>  <p>V5</p>  <p>V6</p>  <p>V8</p>	<p style="text-align: center;">ST</p> <p>ST standard bore foro standard</p>	<p>With Type M specify terminal box position Con tipo M specificare posizione morsettieria</p>  <p>A</p>  <p>B STANDARD</p>  <p>C</p>  <p>D</p>
712C 713C																																																		
I → ø35																																																		
L → ø38																																																		
812C 813C																																																		
M → ø40																																																		
N → ø45																																																		
862C 863C																																																		
P → ø50																																																		
J → ø60																																																		
1002 1003																																																		
J → ø60																																																		
1102 1103																																																		
A → ø70																																																		
712C 713C																																																		
4 → ø200																																																		
5 → ø250																																																		
812C 813C																																																		
5 → ø250																																																		
6 → ø300																																																		
862C 863C																																																		
6 → ø300																																																		
7 → ø350																																																		
1002 1003																																																		
6 → ø300																																																		
7 → ø350																																																		
8 → ø450																																																		
1102 1103																																																		
7 → ø350																																																		
8 → ø450																																																		
713C 813C																																																		
-2 → ø19																																																		
712C 812C 863C																																																		
-3 → ø24																																																		
862C 1003 1103																																																		
-4 → ø28																																																		
1002 1102																																																		
-6 → ø42																																																		
713C 813C																																																		
-1 → ø14 (71B5)																																																		
-2 → ø19 (80B5)																																																		
-3 → ø24 (90B5)																																																		
712C 812C 863C																																																		
-2 → ø19 (80B5)																																																		
-3 → ø24 (90B5)																																																		
-4 → ø28 (100B5)																																																		

POTENZA RICHIESTA / REQUIRED POWER / ERFORDERLICHE LEISTUNG / PUISSANCE NECESSAIRE / POTENCIA NECESARIA

Lifting / sollevamento / hubantriebe / levage / elevación	$P [KW] = \frac{M [Kg] \cdot g [9.81] \cdot v [m / s]}{1000}$
Rotation / rotazione / drehung / rotation / rotacion	$P [KW] = \frac{M [Nm] \cdot n [rpm]}{9550}$
Linear movement / traslazione / linearbewegung / translation / translacion	$P [KW] = \frac{F [N] \cdot v [m / s]}{1000}$

TORQUE / COPPIA / DREHMOMENT / COUPLE / PAR

	$M [Nm] = \frac{9550 \cdot P[KW]}{n [rpm]}$
	$M [lb in] = \frac{63030 \cdot P[HP]}{n [rpm]}$

RADIAL LOADS / CARICHI RADIALI / RADIALE - UND AXIALLASTEN / CHARGES RADIALES / CARGA RADIAL Y AXIAL

- Radial load generated by external transmissions keyed onto input and/or output shafts.
- Forza radiale generata da organi di trasmissione calettati sugli alberi di ingresso e/o uscita.
- Belastungen der Antriebs- bzw. Abtriebswellen durch von aussen eingebrachte Radiallasten.
- Charge radiale générée par la transmissions calés sur les entrées et / ou des arbres de sortie
- Cargas radiales, generada por transmisiones externas, aplicadas sobre los ejes de entrada y/o salida

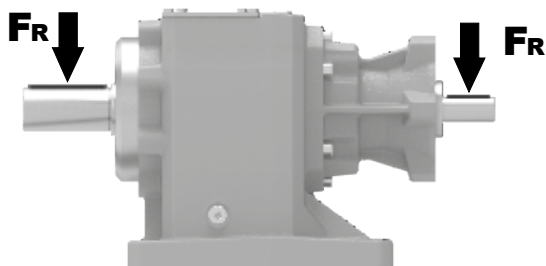

	$F_R [N] = \frac{M [Nm] \cdot 2000}{d [mm]} \cdot f_k$	$F_R [N] = \frac{M [lb in] \cdot 8.9}{d [in]} \cdot f_k$
M	Momento torcente / Output torque / Abtriebsdrehmoment / Couple / Par torsion	
d	Diametro primitivo / Diam. of driving element / Durchmesser der Abtriebseinheit / Diamètre primitif / Diámetro primitivo	
f_k	Coefficiente di trasformazione / Factor / Faktor / Coefficient de transmission / Coeficiente de transmisión 1.15 Ingranaggi / Gearwheels / Zahnrad / Engrenage / Engranaje 1.25 Catena / Chain sprockets / Antriebskette / Chaîne / Cadena 1.75 Cinghia Trapezoidale / Narrow v-belt pulley / Keilriemen / Courroie trap. / Correa trapezoidal 2.50 Cinghia piatta / Flat-belt pulley / Flachzahnriem. / Courroie crantée / Correa plana	

- If your application requires higher radial loads, contact our technical office. Higher load may be possible.
- Nel caso la vostra applicazione richieda carichi radiali superiori consultare il nostro ufficio tecnico, valori maggiori possono essere accettati.
- Wenn Ihre Anwendung höhere Radialbelastungen erfordert, so wenden Sie sich bitte an unser technischen Büro.
- Si votre application demande des charges radiales supérieures, s'adresser à notre bureau technique.
- En el caso en que una aplicación exija una carga radial superior a la especificada en el catálogo, consultar a nuestra oficinas técnica.

How to select a gearbox / Come selezionare un riduttore / Wie wählt man ein Getriebe
Comment sélectionner un réducteur / Cómo seleccionar un reductor

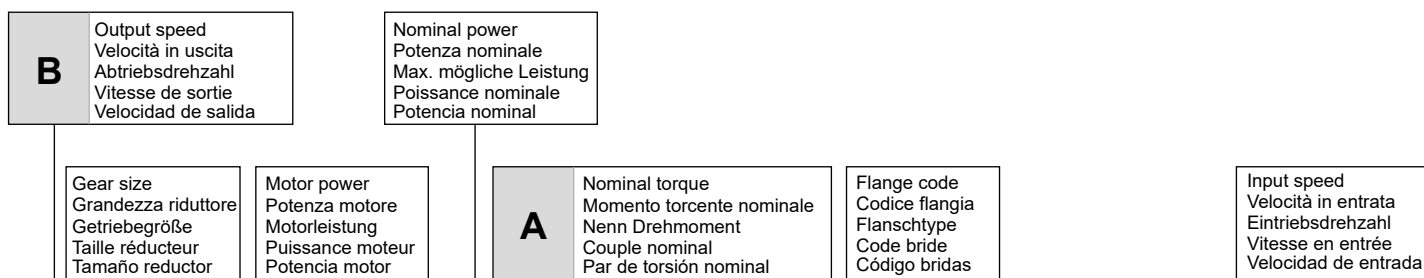

712C

Coaxial - Gear 675Nm

Rating - Cast Iron COAXIAL GEARBOXES



QUICK SELECTION / Selezione veloce

input speed (n_1) = 1400 min⁻¹

Output Speed n_2 [min ⁻¹]	Ratio i	Motor power P_{1M} [kW]	Output torque M_{2M} [Nm]	Service factor f.s.	Nominal power P_{1R} [kW]	Nominal torque M_{2R} [Nm]	Available B5 motor flanges				Available B14 motor flanges				Output Shaft 	Notes Note Anmerkungen Note Notas		
							-D	-E	-F	-G	-R	-T	-U	-V				
364.3	3.84	9	227	1.5	13.91	350	80	90	100	112	132	80	90	100	112	132	3317	01
257.5	5.44	9	321	1.1	10.11	360											3313	02
233.3	6.00	9	354	1.1	9.67	380											3312	03
187.5	7.47	9	440	1.0	8.59	420											3310	04
165.1	8.48	9	500	1.0	8.64	480											2513	05

C Ratio
Rapporto
Untersetzung
Rapport de réduction
Relación

Output shaft diam.
Diam. albero uscita
Durchmesser abtriebswelle
Diametre arbre lent
Diametro eje de salida

Transmitted torque
Momento torcente trasmesso
Mögliche Drehmomente
Couple de sortie
Par transmitido

Service factor
Fattore di servizio
Betriebsfaktor
Facteur de service
Factor de servicio

Type of load and starts per hour Tipo di carico e avviamenti per ora		Oper. hours per day Ore di funz. giorn.		
		3 h	10 h	24 h
Continuous or intermittent appl. with start / hour Applicazione cont. o interm. con n.ro operazioni/ora	Uniform / Uniforme	0.8	1	1.25
	Moderate / Moderato	1	1.25	1.5
	Heavy / Forte	1.25	1.5	1.75
Intermittent application with start / hour Applicazione intermittente con n.ro operazioni/ora	Uniform / Uniforme	1	1.25	1.5
	Moderate / Moderato	1.25	1.5	1.75
	Heavy / Forte	1.5	1.75	2.15

D	Motor flange available Flange disponibili Erhältliche Motorflansche Brides disponibles Bridas disponibles	
B)	Mounting with reduction ring Montaggio con boccia di riduzione Reduzierhülsen Montage avec douille de réduction Montaje con casquillo de reducción	
C)	Motor flangeholes position/terminal box position Posizione fori flangia/basetta motore Bohrungsposition am Motorflansch/-sockel Position trous bride/barrette à bornes moteur Posición agujeros brida / base motor	
B)	Available without reduction bushes Disponibile anche senza boccia Auch ohne Reduzierbuchse verfügbar Disponible aussi sans douille de réduction Disponible tambien sin casquillo	

A	Select required torque (according to service factor)	Seleziona la coppia desiderata (comprensiva del fattore di servizio)	Max. Drehmoment in Bezug zum Betriebsfaktor	Sélectionner le couple souhaité (comprenant le facteur de service)	Seleccionar el par deseado (incluyendo el factor de servicio)
B	Select output speed	Seleziona la velocità in uscita	Ausgewählte Abtriebsdrehzahl	Sélectionner la vitesse de sortie	Seleccionar la velocidad de salida
C	On the same line of selected geared motor, you can find the gear ratio	Sulla riga corrispondente alla motorizzazione prescelta si può rilevare il rapporto di riduzione	Auf der gleichen Linie wie die ausgewählte Motorleistung steht auch die Getriebeuntersetzung	Sur la ligne correspondante à la motorisation pré-choisie on peut relever le rapport de réduction	En la línea correspondiente al motor preseleccionado es posible encontrar la relación de reducción
D	Select motor flange available (if requested)	Scegli la flangia disponibile (se richiesta)	Erhältliche Motorflansche (auf Anfrage)	Choisir la bride disponible (si elle est demandée)	Seleccionar la brida disponible (sobre pedido)



QUICK SELECTION / Selezione veloce

input speed (n_1) = 1400 min⁻¹

Output Speed n_2 [min ⁻¹]	Ratio i	Motor power P_{1M} [kW]	Output torque M_{2M} [Nm]	Service factor $f.s.$	Nominal power P_{1R} [kW]	Nominal torque M_{2R} [Nm]	Available B5 motor flanges				Available B14 motor flanges				Output Shaft \varnothing	Ratios code
							-D	-E	-F	-G	-R	-T	-U	-V		
							80	90	100 112	132	80	90	100 112	132		
364.3	3.84	9	227	1.5	13.91	350								3317		01
257.5	5.44	9	321	1.1	10.11	360								3313		02
233.3	6.00	9	354	1.1	9.67	380								3312		03
187.5	7.47	9	440	1.0	8.59	420								3310		04
165.1	8.48	9	500	1.0	8.64	480								2513		05
149.6	9.36	7.5	444	1.1	8.16	500								2512	standard	06
120.2	11.65	7.5	553	1.1	8.00	610								2510	ø35	07
97.3	14.39	5.5	504	1.2	6.69	630								1713		08
88.1	15.88	5.5	557	1.2	6.35	660								1712		09
70.8	19.76	5.5	693	1.0	5.22	675								1710	On request	10
63.4	22.08	4	566	1.2	4.67	675								1213		11
57.4	24.38	4	625	1.1	4.23	675								1212		12
46.2	30.33	3	586	1.2	3.40	675								1210		13
41.2	34.00	3	656	1.0	3.03	675								912		14
36.1	38.81	2.2	552	1.2	2.66	675								812		15
33.1	42.31	2.2	601	1.1	2.44	675								910		16
29.0	48.30	2.2	687	1.0	2.13	675								810		17

The dynamic efficiency is **0.96** for all ratios

- Motor Flanges Available** Flange Motore Disponibili
- B) Supplied with Reduction Bushing** Fornito con Bussola di Riduzione
- B) Available on Request without reduction bushing** Disponibile a Richiesta senza Bussola di Riduzione
- C) Motor Flange Holes Position** Posizione Fori Flangia Motore

EN Unit **712C** is supplied with synthetic oil for lifetime lubrication, no maintenance is necessary. See table 1 for lubrication and recommended quantity. In table 2 please see possible radial loads and axial loads on the gearbox.

I Il riduttore **712C** viene fornito completo di olio sintetico per la lubrificazione permanente e non necessita di alcuna manutenzione. Vedi tab.1 per oli e quantità consigliati. In tab.2 sono presenti i carichi radiali e assiali applicabili al riduttore.

D Das Getriebe **712C** ist mit synthetischem Öl gefüllt und ist lebensdauer geschmiert. In Tabelle 1 ist die Schmiermenge und das empfohlene Schmiermittel angegeben. In Tabelle 2 sind die zulässigen Radial- und Axialbelastungen des Getriebes aufgeführt.

F Le réducteur **712C** est fourni complet avec de l'huile synthétique pour la lubrification permanente et ne nécessite aucun entretien. Voir tableau 1 concernant les huiles et les quantités conseillées. Les charges radiales et axiales applicables au réducteur sont précisées dans le tableau 2.

E El reductor tamaño **712C** se suministra, lubricado de por vida con aceite sintético y no requieren mantenimiento alguna. Ver tabla 1, para cantidades y aceites recomendados. En la tabla 2, se encuentran las cargas radiales y axiales admitidas por el reductor.

B3	B6	B7	B8	V5	V6	V8
1.50 LT	2.30 LT	1.90 LT	1.70 LT	2.60 LT	2.00 LT	Ask
SHELL Omala S4 WE 320				ENI Telium VSF 320		

For all details on lubrication and plugs check our website **tab. 1**
Per maggiori dettagli su lubrificazione e tappi olio vedi il nostro sito web

RADIAL AND AXIAL LOADS

Output shaft
Albero di uscita

$F_{eq} = FR \cdot \frac{78}{X+38}$

Input shaft
Albero in entrata

n_2	FA	FR	n_2	FA	FR	n_2	FA	FR
300	680	3400	140	960	4800	70	1300	6500
250	760	3800	120	1040	5200	40	1460	7300
200	900	4500	85	1120	5600	15	1800	9000

n_1	FA	FR
1400	450	2250
900	500	2500
500	600	3000

tab. 2



QUICK SELECTION / Selezione veloce

input speed (n_1) = 1400 min⁻¹

Output Speed n_2 [min ⁻¹]	Ratio i	Motor power P_{1M} [kW]	Output torque M_{2M} [Nm]	Service factor f.s.	Nominal power P_{1R} [kW]	Nominal torque M_{2R} [Nm]	Available B5 motor flanges				Available B14 motor flanges			Output Shaft \varnothing	Ratios code
							-B	-C	-D	-E	-Q	-R	-T		
							63	71	80	90	71	80	90		
22.3	62.76	1.5	603	1.1	1.68	675	B				C	C		191213	01
20.2	69.28	1.5	665	1.0	1.52	675	B				C	C		191212	02
19.2	72.75	1.5	698	1.0	1.45	675	B				C	C		171213	03
17.4	80.29	1.5	771	0.9	1.31	675	B				C	C		171212	04
16.4	85.39	1.1	599	1.1	1.23	675	B				C	C		151213	05
14.9	94.25	1.1	661	1.0	1.12	675	B				C	C		151212	06
13.7	101.92	1.1	715	0.9	1.03	675	B				C	C		131213	07
12.4	112.50	0.75	541	1.2	0.94	675	B				C	C		131212	08
11.9	117.29	0.75	564	1.2	0.90	675	B				C	C		151210	09
10.1	139.13	0.75	669	1.0	0.76	675	B				C	C		101213	10
9.1	153.56	0.75	739	0.9	0.69	675	B				C	C		101212	11
7.7	181.57	0.55	644	1.0	0.58	675	B				C	C		91213	12
7.0	200.42	0.55	711	0.9	0.53	675	B				C	C		91212	13
5.6	249.41	0.37	592	1.1	0.42	675	B				C	C		91210	14
4.3	329.33	0.37	781	0.9	0.32	675	B				C	C		71210	15

The dynamic efficiency is **0.94** for all ratios

Motor Flanges Available
Flange Motore Disponibili

B) Supplied with Reduction Bushing
Fornito con Bussola di Riduzione

B) Available on Request without reduction bushing
Disponibile a Richiesta senza Bussola di Riduzione

C) Motor Flange Holes Position
Posizione Fori Flangia Motore

EN Unit **713C** is supplied with synthetic oil for lifetime lubrication, no maintenance is necessary. See table 1 for lubrication and recommended quantity. In table 2 please see possible radial loads and axial loads on the gearbox.

I Il riduttore **713C** viene fornito completo di olio sintetico per la lubrificazione permanente e non necessita di alcuna manutenzione. Vedi tab.1 per oli e quantità consigliati. In tab.2 sono presenti i carichi radiali e assiali applicabili al riduttore.

D Das Getriebe **713C** ist mit synthetischem Öl gefüllt und ist lebensdauergeschmiert. In Tabelle 1 ist die Schmiermenge und das empfohlene Schmiermittel angegeben. In Tabelle 2 sind die zulässigen Radial- und Axialbelastungen des Getriebes aufgeführt.

F Le réducteur **713C** est fourni complet avec de l'huile synthétique pour la lubrification permanente et ne nécessite aucun entretien. Voir tableau 1 concernant les huiles et les quantités conseillées. Les charges radiales et axiales applicables au réducteur sont précisées dans le tableau 2.

E El reductor tamaño **713C** se suministra, lubricado de por vida con aceite sintético y no requieren mantenimiento alguna. Ver tabla 1, para cantidades y aceites recomendados. En la tabla 2, se encuentran las cargas radiales y axiales admitidas por el reductor.

B3	B6	B7	B8	V5	V6	V8
1.60 LT	2.20 LT	1.80 LT	1.70 LT	2.80 LT	1.90 LT	Ask
SHELL Omala S4 WE 320				ENI Telium VSF 320		

For all details on lubrication and plugs check our website
Per maggiori dettagli su lubrificazione e tappi olio vedi il nostro sito web **tab. 1**

RADIAL AND AXIAL LOADS								
Output shaft Albero di uscita			$F_{eq} = F_R \cdot \frac{78}{X+38}$					
n_2	FA	FR	n_2	FA	FR	n_2	FA	FR
300	680	3400	140	960	4800	70	1300	6500
250	760	3800	120	1040	5200	40	1460	7300
200	900	4500	85	1120	5600	15	1800	9000
Input shaft Albero in entrata								
n_1	FA	FR						
1400	400	2000						
900	440	2200						
500	440	2200						

tab. 2



QUICK SELECTION / Selezione veloce

input speed (n_1) = 1400 min⁻¹

Output Speed n_2 [min ⁻¹]	Ratio i	Motor power P_{1M} [kW]	Output torque M_{2M} [Nm]	Service factor $f.s.$	Nominal power P_{1R} [kW]	Nominal torque M_{2R} [Nm]	Available B5 motor flanges				Available B14 motor flanges				Output Shaft \varnothing	Ratios code
							-D	-E	-F	-G	-R	-T	-U	-V		
							80	90	100 112	132	80	90	100 112	132		
364.3	3.84	9	227	2.2	19.47	490								3317	standard $\varnothing 40$	01
257.5	5.44	9	321	1.6	14.61	520								3313		02
233.3	6.00	9	354	1.6	14.00	550								3312		03
187.5	7.47	9	440	1.4	12.27	600								3310		04
165.1	8.48	9	500	1.3	11.43	635								2513		05
149.6	9.36	9	552	1.2	10.44	640								2512		06
120.2	11.65	9	687	1.0	8.65	660								2510		07
97.3	14.39	7.5	683	1.1	7.64	720								1713		08
88.1	15.88	7.5	754	1.0	7.21	750								1712		09
70.8	19.76	7.5	938	0.9	6.34	820								1710		On request
63.4	22.08	5.5	774	1.1	5.98	865								1213		11
57.4	24.38	5.5	854	1.0	5.42	865								1212		12
46.2	30.33	4	778	1.1	4.35	865								1210		13
41.2	34.00	4	872	1.0	3.88	865								912		14
36.1	38.81	3	749	1.1	3.33	846								812		15
33.1	42.31	3	817	1.1	3.12	865								910		16
29.0	48.30	3	932	0.9	2.73	865								810		17

The dynamic efficiency is **0.96** for all ratios

A) Motor Flanges Available
Flange Motore Disponibili

B) Supplied with Reduction Bushing
Fornito con Bussola di Riduzione

B) Available on Request without reduction bushing
Disponibile a Richiesta senza Bussola di Riduzione

C) Motor Flange Holes Position
Posizione Fori Flangia Motore

E Unit **812C** is supplied with synthetic oil for lifetime lubrication, no maintenance is necessary. See table 1 for lubrication and recommended quantity. In table 2 please see possible radial loads and axial loads on the gearbox.

I Il riduttore **812C** viene fornito completo di olio sintetico per la lubrificazione permanente e non necessita di alcuna manutenzione. Vedi tab.1 per oli e quantità consigliati. In tab.2 sono presenti i carichi radiali e assiali applicabili al riduttore.

D Das Getriebe **812C** ist mit synthetischem Öl gefüllt und ist lebensdauergeschmiert. In Tabelle 1 ist die Schmiermenge und das empfohlene Schmiermittel angegeben. In Tabelle 2 sind die zulässigen Radial - und Axialbelastungen des Getriebes aufgeführt.

F Le réducteur **812C** est fourni complet avec de l'huile synthétique pour la lubrification permanente et ne nécessite aucun entretien. Voir tableau 1 concernant les huiles et les quantités conseillées. Les charges radiales et axiales applicables au réducteur sont précisées dans le tableau 2.

E El reductor tamaño **812C** se suministra, lubricado de por vida con aceite sintético y no requieren mantenimiento alguna. Ver tabla 1, para cantidades y aceites recomendados. En la tabla 2, se encuentran las cargas radiales y axiales admitidas por el reductor.

B3	B6	B7	B8	V5	V6	V8
1.50 LT	2.30 LT	1.90 LT	1.70 LT	2.60 LT	2.00 LT	Ask
SHELL Omala S4 WE 320				ENI Telium VSF 320		

For all details on lubrication and plugs check our website **tab. 1**
Per maggiori dettagli su lubrificazione e tappi olio vedi il nostro sito web

RADIAL AND AXIAL LOADS

Output shaft
Albero di uscita

$F_{eq} = FR \cdot \frac{78}{X+38}$

n_2	FA	FR	n_2	FA	FR	n_2	FA	FR
300	1300	6500	140	1780	8900	70	2200	11000
250	1420	7100	120	1900	9500	40	2360	11800
200	1600	8000	85	2040	10200	15	2400	12000

Input shaft
Albero in entrata

n_1	FA	FR
1400	450	2250
900	500	2500
500	600	3000

tab. 2

P812C**S7**... With feet
Con piedini

Gearbox weight **33.7 kg**
peso riduttore With flange
With feet **39.2 kg**

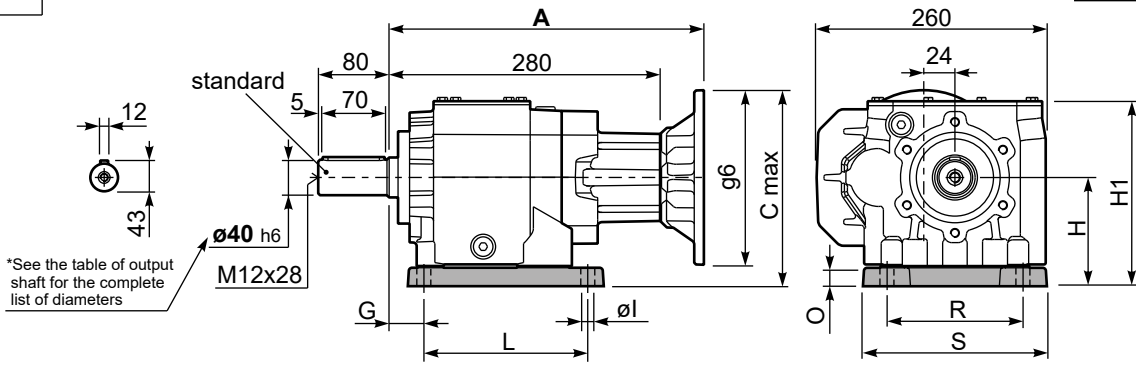

Feet / piedini

Feet Code	Market reference	G	H	R	L	S	H1	O	øI	B5 max. Flange	kit code
B5	512/3	25	155	225	156	270	245.5	30	18	-	KC81.9.022
S7	77	35	140	170	205	230	230.5	30	17.5	-	KC81.9.024

P812C-**F**... Output flanges
flange di uscita

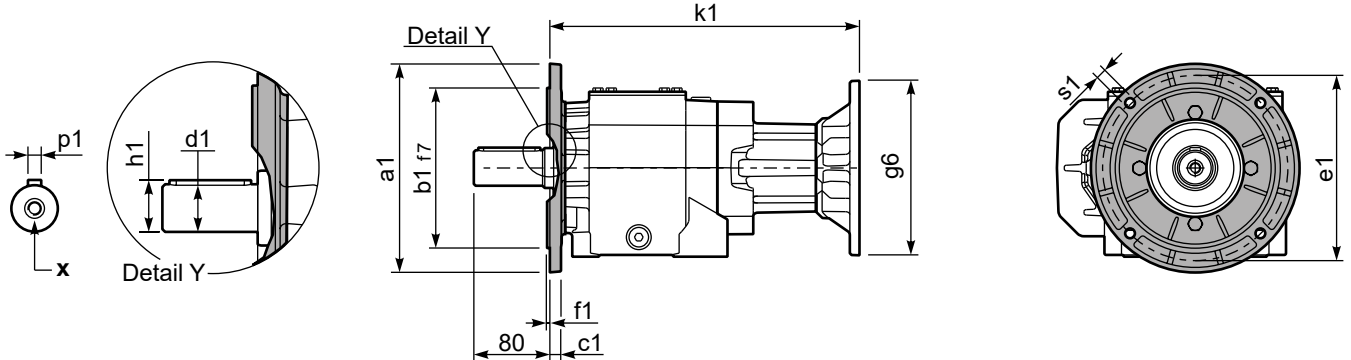

***Available output shaft / Albero di uscita**

	Shaft - d1	p1	h1	x
Standard	ø 40x80	12	43	M12x28
On request A richiesta	ø 45x90	14	48.5	M14x34

Available output flanges / flange di uscita

a1 ø	b1	c1	e1	f1	s1	kit code
250	180	13	215	4	14	KC81.9.013
300	230	16	265	4	14	KC81.9.014
-	-	-	-	-	-	-

With flange and feet only on request. Ask for compatibility

P812C-**N**... Basic gearbox
Riduttore base

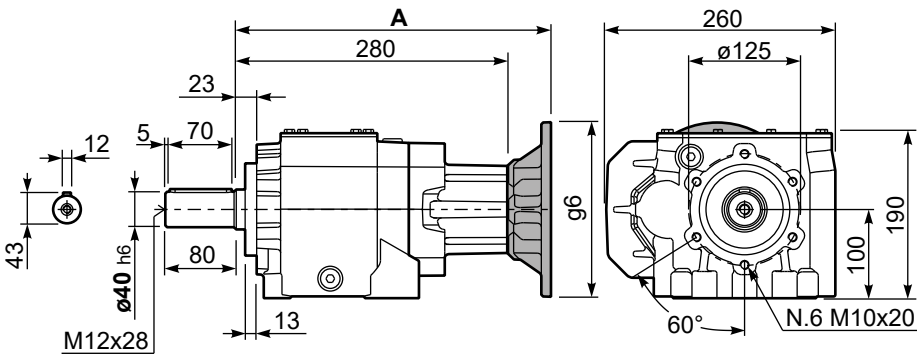

R812C-N... Input Shaft
Albero in entrata

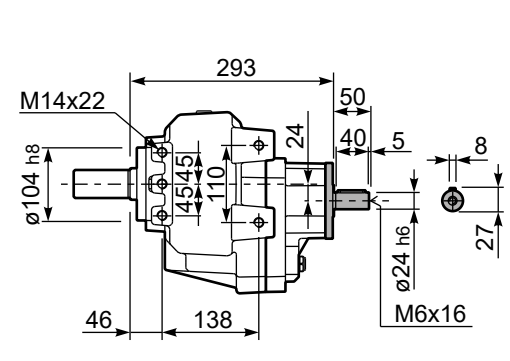

B5 Motor Flanges	A	C _{max}	g6	k1	kit code
80/90 B5	300.5	255	200	300.5	K023.4.042
100/112 B5	309.5	280	250	309.5	K023.4.043
132 B5	331	305	300	331	KC51.4.043C

B14 Motor Flanges	A	C _{max}	g6	k1	kit code
80 B14	300.5	215	120	300.5	K085.4.046
90 B14	300.5	225	140	300.5	K085.4.045
100/112 B14	309.5	235	160	309.5	K085.4.047
132 B14	331	255	200	331	KC51.4.041C



QUICK SELECTION / Selezione veloce

input speed (n_1) = 1400 min⁻¹

Output Speed n_2 [min ⁻¹]	Ratio i	Motor power P_{1M} [kW]	Output torque M_{2M} [Nm]	Service factor f.s.	Nominal power P_{1R} [kW]	Nominal torque M_{2R} [Nm]	Available B5 motor flanges					Available B14 motor flanges				Output Shaft \varnothing	Ratios code
							-B	-C	-D	-E	-F	-Q	-R	-T	-U		
							63	71	80	90	100	71	80	90	100		
22.3	62.76	2.2	874	1.0	2.15	865	B					C	C			191213	01
20.2	69.28	2.2	965	0.9	1.95	865	B					C	C			191212	02
19.2	72.75	1.5	698	1.2	1.85	865	B					C	C			171213	03
17.4	80.29	1.5	771	1.1	1.68	865	B					C	C			171212	04
16.4	85.39	1.5	820	1.1	1.58	865	B					C	C			151213	05
14.9	94.25	1.5	905	1.0	1.43	865	B					C	C			151212	06
13.7	101.92	1.1	715	1.2	1.32	865	B					C	C			131213	07
12.4	112.50	1.1	789	1.1	1.20	865	B					C	C			131212	08
11.9	117.29	1.1	822	1.1	1.15	865	B					C	C			151210	09
10.1	139.13	1.1	976	0.9	0.97	865	B					C	C			101213	10
9.1	153.56	0.75	739	1.2	0.88	865	B					C	C			101212	11
7.7	181.57	0.75	873	1.0	0.74	865	B					C	C			91213	12
7.0	200.42	0.55	711	1.2	0.67	865	B					C	C			91212	13
5.6	249.41	0.55	885	1.0	0.54	865	B					C	C			91210	14
4.3	329.33	0.37	781	1.1	0.41	865	B					C	C			71210	15

The dynamic efficiency is **0.94** for all ratios

 Motor Flanges Available Flange Motore Disponibili
 B) Supplied with Reduction Bushing Fornito con Bussola di Riduzione
 B) Available on Request without reduction bushing Disponibile a Richiesta senza Bussola di Riduzione
 C) Motor Flange Holes Position Posizione Fori Flangia Motore

EN Unit **813C** is supplied with synthetic oil for lifetime lubrication, no maintenance is necessary. See table 1 for lubrication and recommended quantity. In table 2 please see possible radial loads and axial loads on the gearbox.

I Il riduttore **813C** viene fornito completo di olio sintetico per la lubrificazione permanente e non necessita di alcuna manutenzione. Vedi tab.1 per oli e quantità consigliati. In tab.2 sono presenti i carichi radiali e assiali applicabili al riduttore.

D Das Getriebe **813C** ist mit synthetischem Öl gefüllt und ist lebensdauergeschmiert. In Tabelle 1 ist die Schmiermenge und das empfohlene Schmiermittel angegeben. In Tabelle 2 sind die zulässigen Radial- und Axialbelastungen des Getriebes aufgeführt.

F Le réducteur **813C** est fourni complet avec de l'huile synthétique pour la lubrification permanente et ne nécessite aucun entretien. Voir tableau 1 concernant les huiles et les quantités conseillées. Les charges radiales et axiales applicables au réducteur sont précisées dans le tableau 2.

E El reductor tamaño **813C** se suministra, lubricado de por vida con aceite sintético y no requieren mantenimiento alguna. Ver tabla 1, para cantidades y aceites recomendados. En la tabla 2, se encuentran las cargas radiales y axiales admitidas por el reductor.

B3	B6	B7	B8	V5	V6	V8
1.60 LT	2.20 LT	1.80 LT	1.70 LT	2.80 LT	1.90 LT	Ask

SHELL Omala S4 WE 320 **ENI** Telium VSF 320

For all details on lubrication and plugs check our website **tab. 1**
Per maggiori dettagli su lubrificazione e tappi olio vedi il nostro sito web

RADIAL AND AXIAL LOADS

Output shaft
Albero di uscita

$F_{eq} = FR \cdot \frac{78}{X+38}$

n_2	FA	FR	n_2	FA	FR	n_2	FA	FR
300	1300	6500	140	1780	8900	70	2200	11000
250	1420	7100	120	1900	9500	40	2360	11800
200	1600	8000	85	2040	10200	15	2400	12000

Input shaft
Albero in entrata

n_1	FA	FR
1400	400	2000
900	440	2200
500	440	2200

tab. 2

P813C**S7**... With feet
Con piedini

Gearbox weight **34.8 kg**
peso riduttore With flange
With feet **40.3 kg**

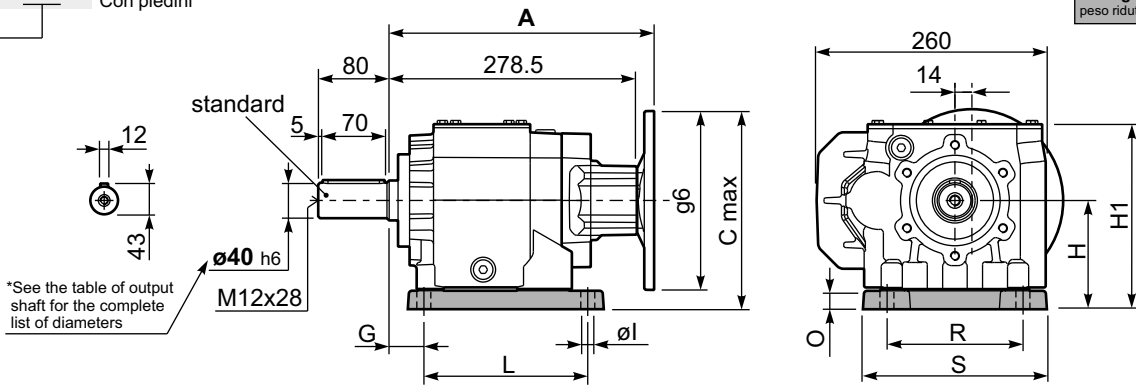

Feet / piedini

Feet Code	Market reference	G	H	R	L	S	H1	O	øl	B5 max. Flange	kit code
B5	512/3	25	155	225	156	270	245.5	30	18	-	KC81.9.022
S7	77	35	140	170	205	230	230.5	30	17.5	-	KC81.9.024

P813C-**F**... Output flanges
flange di uscita

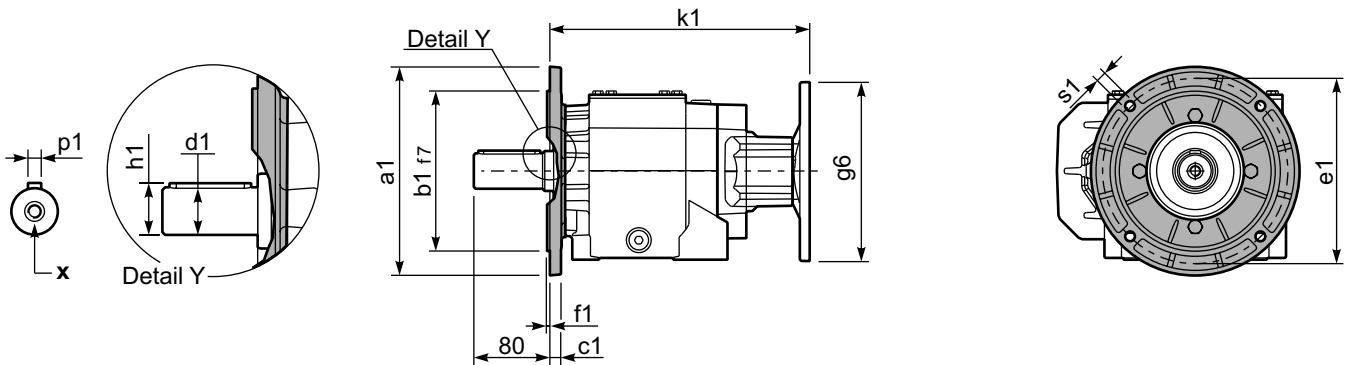

*Available output shaft / Albero di uscita

	Shaft - d1	p1	h1	x
Standard	ø 40x80	12	43	M12x28
On request A richiesta	ø 45x90	14	48.5	M14x34

Available output flanges / flange di uscita

a1 ø	b1	c1	e1	f1	s1	kit code
250	180	13	215	4	14	KC81.9.013
300	230	16	265	4	14	KC81.9.014
-	-	-	-	-	-	-

With flange and feet only on request. Ask for compatibility

P813C-**N**... Basic gearbox
Riduttore base

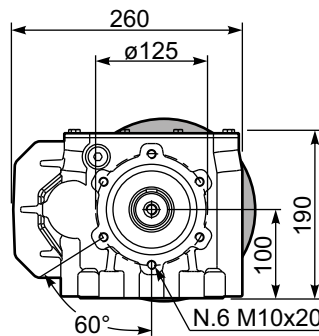
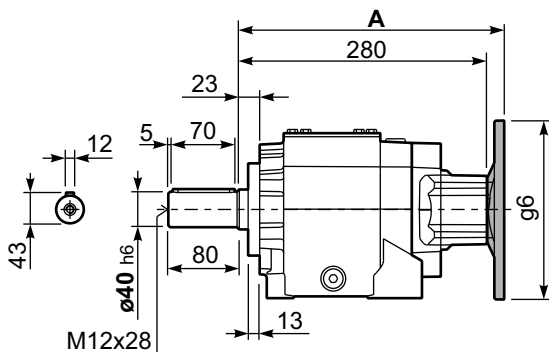

R813C-**N**... Input Shaft
Albero in entrata

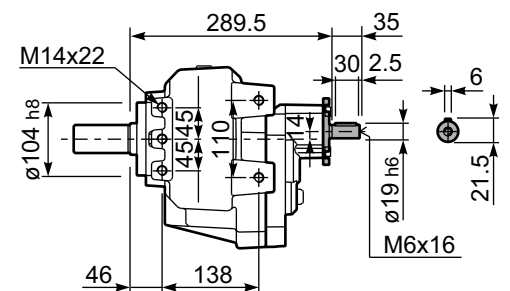

B5 Motor Flanges	A	C _{max}	g6	k1	kit code
63 B5	299	225	140	299	K063.4.041
71 B5	297	235	160	297	K063.4.042
80/90 B5	299	255	200	299	K063.4.043
100/112 B5	314	280	250	314	KC40.4.043

B14 Motor Flanges	A	C _{max}	g6	k1	kit code
71 B14	297	207.5	105	297	K063.4.047
80 B14	299	215	120	299	K063.4.046
90 B14	299	225	140	299	K063.4.041
100/112 B14	314	235	160	314	KC40.4.041

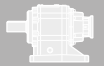

QUICK SELECTION / Selezione veloce

input speed (n_1) = 1400 min⁻¹

Output Speed n_2 [min ⁻¹]	Ratio i	Motor power P_{1M} [kW]	Output torque M_{2M} [Nm]	Service factor f.s.	Nominal power P_{1R} [kW]	Nominal torque M_{2R} [Nm]	B5 motor flanges				B14 motor flanges		Output Shaft 	Ratios code
							-F	-G	-H	-I	-U	-V		
							100 112	132	160	180	100 112	132		
317	4.42	22	611	1.1	24.2	700						3015	01	
264	5.30	22	733	1.0	20.2	700						3013	02	
219	6.38	18.5	742	1.1	19.1	800						3011	03	
168	8.33	15	784	1.0	14.7	800						2015	04	
140	9.99	15	940	1.0	13.8	900						2013	05	
124	11.26	15	1060	1.0	14.9	1100						1615	06	
116	12.03	15	1132	1.1	15.2	1200						2011	07	
104	13.50	15	1271	1.1	15.8	1400						1613	08	
96	14.65	15	1378	1.1	15.6	1500						1315	09	
86	16.26	15	1531	1.0	14.1	1500						1611	10	
80	17.56	11	1214	1.2	13.0	1500						1313	11	
65	21.50	11	1486	1.1	11.4	1600						1113	12	
54	25.88	9	1526	1.0	9.4	1600						1111	13	
45.0	31.09	7.5	1475	1.0	7.2	1460						813	14	
37.4	37.43	5.5	1312	1.2	6.5	1600						811	15	

The dynamic efficiency is **0.96** for all ratios

Motor Flanges Available
Flange Motore Disponibili

B) Supplied with Reduction Bushing
Fornito con Bussola di Riduzione

B) Available on Request without reduction bushing
Disponibile a Richiesta senza Bussola di Riduzione

C) Motor Flange Holes Position
Posizione Fori Flangia Motore

EN Unit **862C** is supplied without lubricant and equipped with a breather, level and drain plugs. User can add mineral oil keeping existing plugs. Should the user wish to fill it with synthetic oil, it is recommended to replace the existing plugs with a closed plug.
See table 1 for lubrication and recommended quantity.
In table 2 please see possible radial loads and axial loads on the gearbox.

I Il riduttore tipo **862C** è fornito privo di lubrificazione con tappi di sfiato, livello e scarico olio. L'utente può immettere olio minerale mantenendo i tappi esistenti. Se immetterà olio sintetico, dovrà sostituire i tappi esistenti con altri tipo chiuso.
Tab.1 per oli e quantità consigliati.
Tab.2 carichi radiali e assiali applicabili al riduttore.

D Das Getriebe der Baugröße **862C** wird ohne Schmiermittel geliefert. Es ist jedoch mit Einfüllschraube, Überdruckventil und Ablassschraube ausgerüstet. Das benötigte mineralische Öl kann über die Einfüllschraube eingefüllt werden. Sollte synthetisches Öl bevorzugt werden, so ist sind das eingebaute Überdruckventil durch eine geschlossenen Schraube zu ersetzen.
In Tabelle 1 ist die Schmiermenge und das empfohlene Schmiermittel angegeben
In Tabelle 2 sind die zulässigen Radial - und Axialbelastungen des Getriebes aufgeführt.

F Le réducteur de type **862C** est fourni sans lubrification et avec un bouchon de remplissage, de niveau et d'évacuation de l'huile. L'utilisateur peut y verser de l'huile minérale en conservant les bouchons existants. S'il y versera de l'huile synthétique, il devra substituer les bouchons existants avec d'autres bouchons de type fermé.
Voir tableau 1 concernant les huiles et les quantités conseillées.
Voir tableau 2 concernant les charges radiales et axiales applicables au réducteur

E El reductor tamaño **862C** se suministra sin lubricante, provisto de tapones de respiración, nivel y descarga de aceite. El usuario puede utilizar aceite mineral, manteniendo los tapones existentes. Si prefiere utilizar aceite sintético deberá sustituir los tapones existentes por tapones ciegos. La prerreducción se suministra con tapones ciegos, lubricado de por vida con aceite sintético.
Ver tabla 1, para cantidades y aceites recomendados.
En la tabla 2, se encuentran las cargas radiales y axiales admitidas por el reductor.

B3	B6	B7	B8	V5	V6	V8
3.10 LT	4.50 LT	2.50 LT	3.10 LT	4.90 LT	4.20 LT	Ask
SHELL Omala S2 GX 460				ENI Blasias 460		

For all details on lubrication and plugs check our website **tab. 1**
Per maggiori dettagli su lubrificazione e tappi olio vedi il nostro sito web

RADIAL AND AXIAL LOADS

Output shaft
Albero di uscita

$F_{eq} = F_R \cdot \frac{88.5}{X+38.5}$

n_2	FA	FR	n_2	FA	FR	n_2	FA	FR
300	1800	9000	140	2400	12000	70	3000	15000
250	2000	10000	120	2600	13000	40	3200	16000
200	2200	11000	85	2800	14000	15	4000	20000

On request reinforced bearings to increase loads.
A richiesta cuscinetti rinforzati per aumentare i carichi.

Input shaft
Albero in entrata

n_1	FA	FR
1400	700	3500
900	840	4200
500	900	4500

tab. 2

P862C**S8**... With foot
Con piedino

Gearbox weight With flange **84.0 kg**
peso riduttore With feet **74.5 kg**

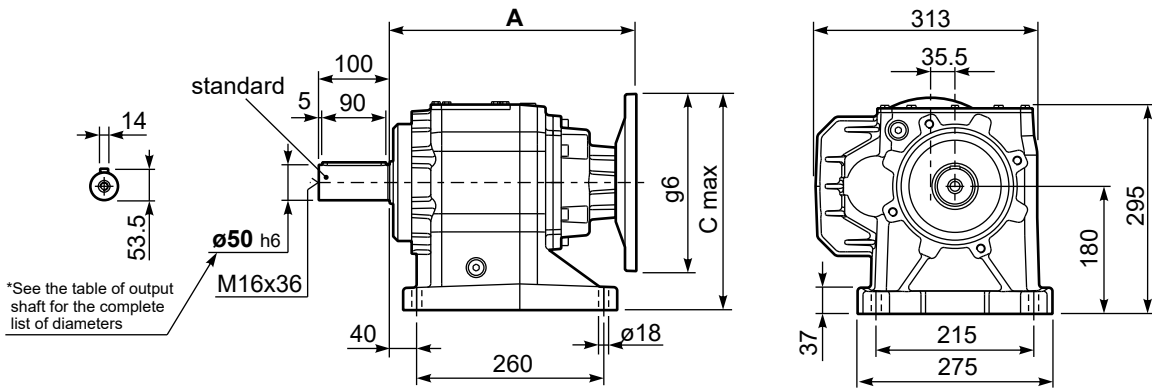

P862C-**F**... Output flanges
flange di uscita

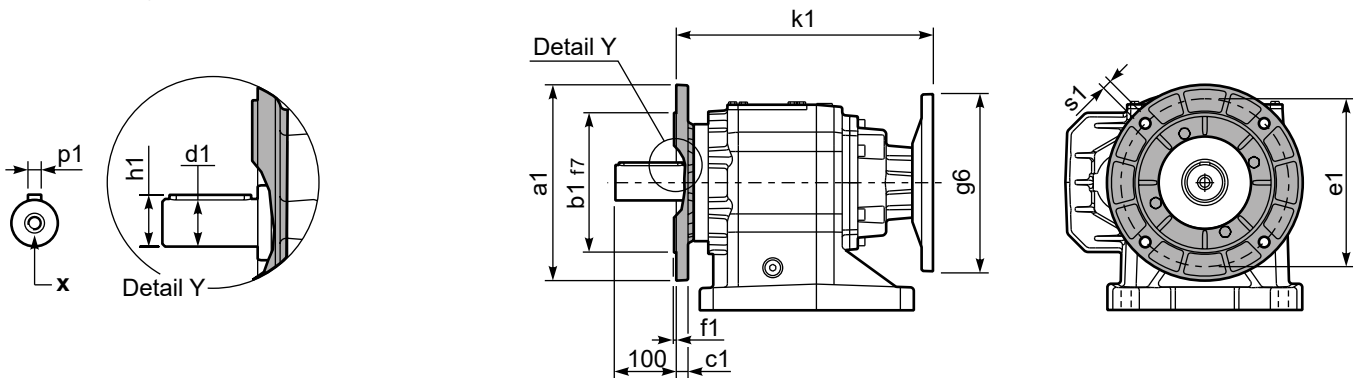

*Available output shaft / Albero di uscita

	Shaft - d1	p1	h1	x
Standard	ø 50x100	14	53.5	M16x36
On request A richiesta	ø 60x120	18	64	M20x42
	-	-	-	-

Available output flanges / flange di uscita

a1 ø	b1	c1	e1	f1	s1	kit code
300	230	21	265	4	14	KC90.9.014
350	250	21	300	5	18	KC90.9.015
-	-	-	-	-	-	-

All flanges are compatible with the foot

P862C**S8**... Basic gearbox
Riduttore base

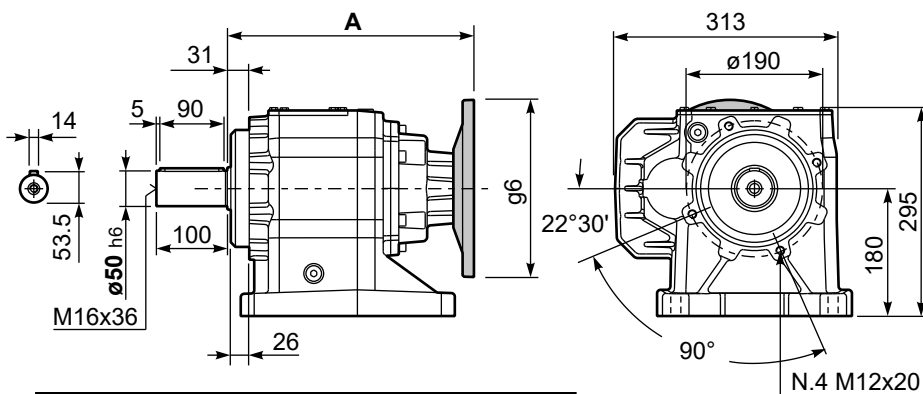

B5 Motor Flanges	A	C _{max}	g6	k1	kit code
100/112 B5	348.5	305	250	348.5	K023.4.043
132 B5	370	330	300	370	KC51.4.043C
160/180 B5	402	355	350	402	KC86.4.0.43

B14 Motor Flanges	A	C _{max}	g6	k1	kit code
100/112 B14	348.5	260	160	348.5	K085.4.047
132 B14	370	280	200	370	KC51.4.041C
-	-	-	-	-	-

R862C**S8**... Input Shaft
Albero in entrata

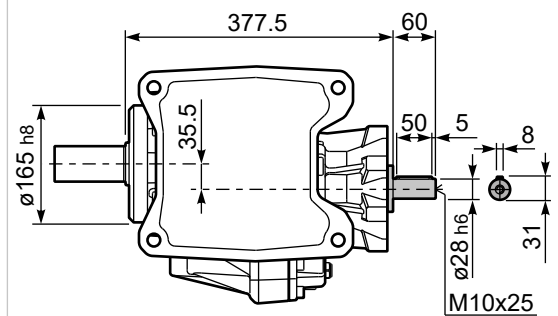

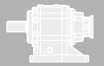

QUICK SELECTION / Selezione veloce

input speed (n_1) = 1400 min⁻¹

Output Speed n_2 [min ⁻¹]	Ratio i	Motor power P_{1M} [kW]	Output torque M_{2M} [Nm]	Service factor $f.s.$	Nominal power P_{1R} [kW]	Nominal torque M_{2R} [Nm]	Available B5 motor flanges					Available B14 motor flanges				Output Shaft \varnothing	Ratios code	
							-C	-D	-E	-F	-G	-R	-T	-U	-V			
							71	80	90	100 112	132	80	90	100 112	132			
32.5	43.03	5.5	1478	1.1	5.8	1600	B									201313	standard $\varnothing 50$ $\varnothing 60$ On request	01
28.9	48.52	5.5	1667	0.9	5.0	1550	B									161315		02
27.0	51.81	4	1302	1.2	4.8	1600	B									201311		03
24.1	58.17	4	1462	1.1	4.3	1600	B									161313		04
22.2	63.09	4	1585	1.0	3.8	1550	B									131315		05
20.0	70.05	4	1760	1.0	4.0	1800	B									161311		06
18.5	75.65	4	1901	0.9	3.7	1800	B									131313		07
15.4	91.09	3	1723	1.0	3.1	1800	B									131311		08
12.6	111.50	2.2	1553	1.2	2.5	1800	B									111311		09
10.5	133.91	2.2	1865	1.0	2.1	1800	B									81313		10
8.7	161.24	1.5	1548	1.2	1.7	1800	B									81311		11
7.6	184.40	1.1	1293	1.1	1.2	1450	B									61313		12
6.3	222.04	1.1	1557	1.1	1.2	1750	B									61311		13

The dynamic efficiency is **0.94** for all ratios

A Motor Flanges Available
Flange Motore Disponibili

B Supplied with Reduction Bushing
Fornito con Bussola di Riduzione

B Available on Request without reduction bushing
Disponibile a Richiesta senza Bussola di Riduzione

C Motor Flange Holes Position
Posizione Fori Flangia Motore

EN Unit **863C** is supplied without lubricant and equipped with a breather, level and drain plugs. User can add mineral oil keeping existing plugs. Should the user wish to fill it with synthetic oil, it is recommended to replace the existing plugs with a closed plug.
See table 1 for lubrication and recommended quantity.
In table 2 please see possible radial loads and axial loads on the gearbox.

I Il riduttore tipo **863C** è fornito privo di lubrificazione con tappi di sfiato, livello e scarico olio. L'utente può immettere olio minerale mantenendo i tappi esistenti. Se immetterà olio sintetico, dovrà sostituire i tappi esistenti con altri tipo chiuso.
Tab.1 per oli e quantità consigliati.
Tab.2 carichi radiali e assiali applicabili al riduttore.

D Das Getriebe der Baugröße **863C** wird ohne Schmiermittel geliefert. Es ist jedoch mit Einfüllschraube, Überdruckventil und Ablassschraube ausgerüstet. Das benötigte mineralische Öl kann über die Einfüllschraube eingefüllt werden. Sollte synthetisches Öl bevorzugt werden, so ist sind das eingebaute Überdruckventil durch eine geschlossenen Schraube zu ersetzen.
In Tabelle 1 ist die Schmiermenge und das empfohlene Schmiermittel angegeben
In Tabelle 2 sind die zulässigen Radial - und Axialbelastungen des Getriebes aufgeführt.

F Le réducteur de type **863C** est fourni sans lubrification et avec un bouchon de remplissage, de niveau et d'évacuation de l'huile. L'utilisateur peut y verser de l'huile minérale en conservant les bouchons existants. S'il y versera de l'huile synthétique, il devra substituer les bouchons existants avec d'autres bouchons de type fermé.
Voir tableau 1 concernant les huiles et les quantités conseillées.
Voir tableau 2 concernant les charges radiales et axiales applicables au réducteur

E El reductor tamaño **863C** se suministra sin lubricante, provisto de tapones de respiración, nivel y descarga de aceite. El usuario puede utilizar aceite mineral, manteniendo los tapones existentes. Si prefiere utilizar aceite sintético deberá sustituir los tapones existentes por tapones ciegos. La prerreducción se suministra con tapones ciegos, lubricado de por vida con aceite sintético.
Ver tabla 1, para cantidades y aceites recomendados.
En la tabla 2, se encuentran las cargas radiales y axiales admitidas por el reductor.

B3	B6	B7	B8	V5	V6	V8
3.10 LT	4.60 LT	2.60 LT	3.10 LT	5.60 LT	4.30 LT	Ask
SHELL Omala S2 GX 460				ENI Blasias 460		

For all details on lubrication and plugs check our website **tab. 1**
Per maggiori dettagli su lubrificazione e tappi olio vedi il nostro sito web

RADIAL AND AXIAL LOADS

Output shaft
Albero di uscita

$F_{eq} = FR \cdot \frac{88.5}{X+38.5}$

n_2	FA	FR	n_2	FA	FR	n_2	FA	FR
300	1800	9000	140	2400	12000	70	3000	15000
250	2000	10000	120	2600	13000	40	3200	16000
200	2200	11000	85	2800	14000	15	4000	20000

On request reinforced bearings to increase loads.
A richiesta cuscinetti rinforzati per aumentare i carichi.

Input shaft
Albero in entrata

n_1	FA	FR
1400	450	2250
900	500	2500
500	600	3000

tab. 2

P863C**S8**... With foot
Con piedino

Gearbox weight With flange **78.5 kg**
peso riduttore With feet **69.0 kg**

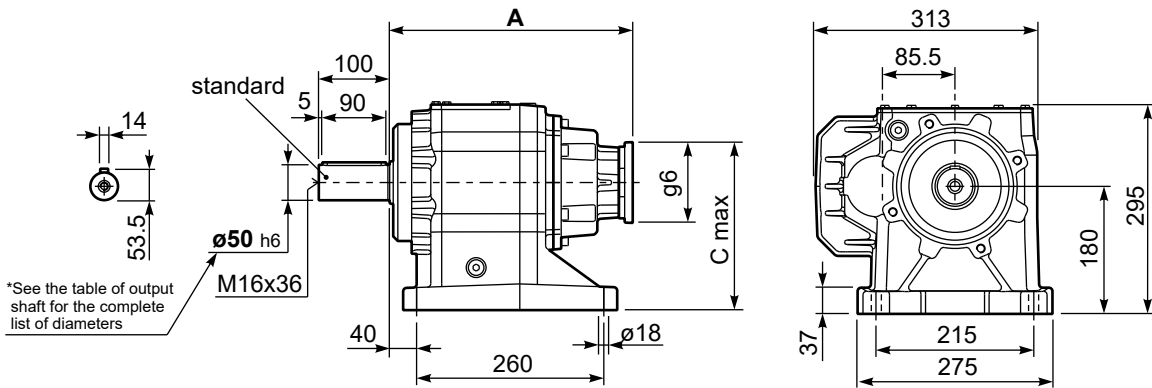

P863C-**F**... Output flanges
flange di uscita

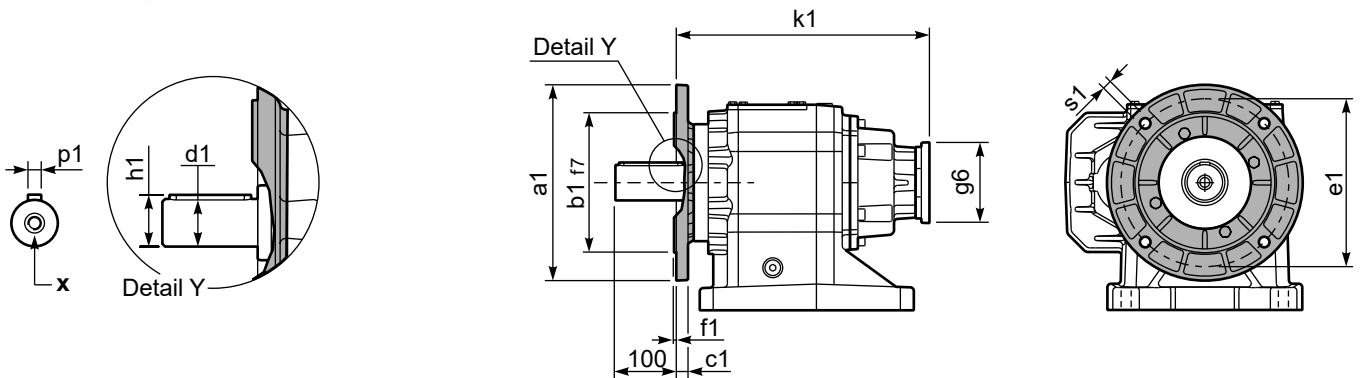

*Available output shaft / Albero di uscita

	Shaft - d1	p1	h1	x
Standard	ø 50x100	14	53.5	M16x36
On request A richiesta	ø 60x120	18	64	M20x42

Available output flanges / flange di uscita

a1 ø	b1	c1	e1	f1	s1	kit code
300	230	21	265	4	14	KC90.9.014
350	250	21	300	5	18	KC90.9.015
-	-	-	-	-	-	-

All flanges are compatible with the foot

P863C**S8**... Basic gearbox
Riduttore base

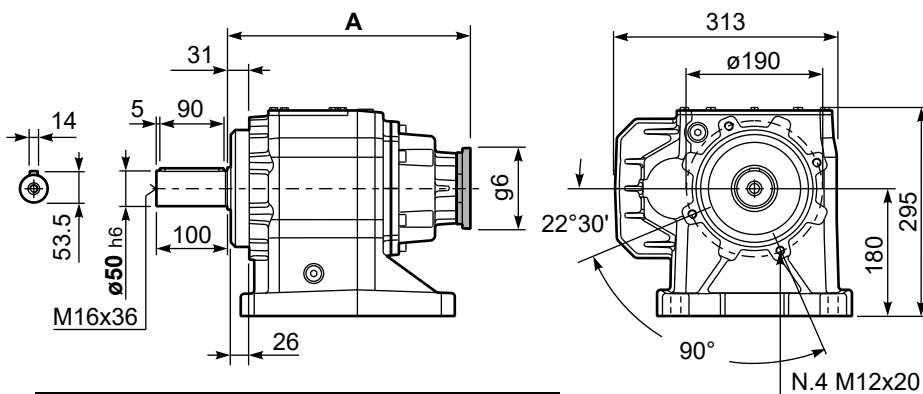

B5 Motor Flanges	A	C _{max}	g6	k1	kit code
71 B5	342	260	160	344	K023.4.041
80/90 B5	344	280	200	344	K023.4.042
100/112 B5	353	305	250	353	K023.4.043
132 B5	374	330	300	374	KC51.4.043

B14 Motor Flanges	A	C _{max}	g6	k1	kit code
80 B14	344	240	120	344	K085.4.046
90 B14	344	250	140	344	K085.4.045
100/112 B14	353	260	160	353	K085.4.047
132 B14	374	280	200	374	KC51.4.041

R863C**S8**... Input Shaft
Albero in entrata

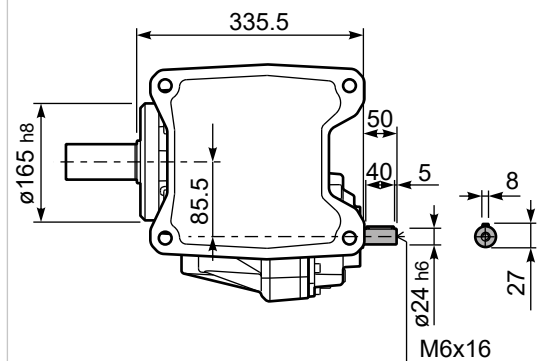

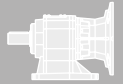

QUICK SELECTION / Selezione veloce

input speed (n_1) = 1400 min⁻¹

Output Speed n_2 [min ⁻¹]	Ratio i	Motor power P_{1M} [kW]	Output torque M_{2M} [Nm]	Service factor $f.s.$	Nominal power P_{1R} [kW]	Nominal torque M_{2R} [Nm]	B5 motor flanges				B14 motor flanges				Output Shaft 	Ratios code
							-G	-H	-I	-L	-	-	-	-		
							132	160	180	200	-	-	-	-		
294	4.75	30	895	1.8	53.0	1650									3914	01
269	5.21	30	980	1.8	51.3	1750									3913	02
220	6.36	30	1197	1.6	45.6	1900									3911	03
188	7.45	30	1401	1.5	43.1	2100									3014	04
172	8.15	30	1535	1.4	39.3	2100									3013	05
141	9.96	30	1874	1.2	33.7	2200									3011	06
120	11.69	30	2200	1.0	30.1	2300									2214	07
109	12.80	30	2409	1.0	27.4	2300									2213	08
90	15.63	22	2161	1.1	23.5	2400									2211	09
79	17.65	22	2441	1.1	22.5	2600									1614	10
72	19.33	22	2673	1.1	22.9	2900									1613	11
67	20.77	22	2872	1.0	21.3	2900									1414	12
62	22.75	18.5	2643	1.1	19.5	2900									1413	13
59	23.60	18.5	2743	1.1	18.8	2900									1611	14
50	27.78	15	2615	1.1	15.9	2900									1411	15
45.5	30.76	15	2896	1.0	14.4	2900									1014	16
41.6	33.69	11	2330	1.2	13.1	2900									1013	17
34.0	41.15	11	2845	1.0	10.8	2900									1011	18

The dynamic efficiency is **0.96** for all ratios

Motor Flanges Available
Flange Motore Disponibili

B) Supplied with Reduction Bushing
Fornito con Bussola di Riduzione

B) Available on Request without reduction bushing
Disponibile a Richiesta senza Bussola di Riduzione

C) Motor Flange Holes Position
Posizione Fori Flangia Motore

EN Unit **1002** is supplied without lubricant and equipped with a breather, level and drain plugs. User can add mineral oil keeping existing plugs. Should the user wish to fill it with synthetic oil, it is recommended to replace the existing plugs with a closed plug.
See table 1 for lubrication and recommended quantity. In table 2 please see possible radial loads and axial loads on the gearbox.

I Il riduttore tipo **1002** è fornito privo di lubrificazione con tappi di sfiato, livello e scarico olio. L'utente può immettere olio minerale mantenendo i tappi esistenti. Se immetterà olio sintetico, dovrà sostituire i tappi esistenti con altri tipo chiuso.
Tab.1 per oli e quantità consigliati.
Tab.2 carichi radiali e assiali applicabili al riduttore.

D Das Getriebe der Baugröße **1002** wird ohne Schmiermittel geliefert. Es ist jedoch mit Einfüllschraube, Überdruckventil und Ablassschraube ausgerüstet. Das benötigte mineralische Öl kann über die Einfüllschraube eingefüllt werden. Sollte synthetisches Öl bevorzugt werden, so ist sind das eingebaute Überdruckventil durch eine geschlossenen Schraube zu ersetzen.
In Tabelle 1 ist die Schmiermenge und das empfohlene Schmiermittel angegeben
In Tabelle 2 sind die zulässigen Radial - und Axialbelastungen des Getriebes aufgeführt.

F Le réducteur de type **1002** est fourni sans lubrification et avec un bouchon de remplissage, de niveau et d'évacuation de l'huile. L'utilisateur peut y verser de l'huile minérale en conservant les bouchons existants. S'il y versera de l'huile synthétique, il devra substituer les bouchons existants avec d'autres bouchons de type fermé.
Voir tableau 1 concernant les huiles et les quantités conseillées.
Voir tableau 2 concernant les charges radiales et axiales applicables au réducteur

E El reductor tamaño **1002** se suministra sin lubricante, provisto de tapones de respiración, nivel y descarga de aceite. El usuario puede utilizar aceite mineral, manteniendo los tapones existentes. Si prefiere utilizar aceite sintético deberá sustituir los tapones existentes por tapones ciegos. La prerreducción se suministra con tapones ciegos, lubricado de por vida con aceite sintético. Ver tabla 1, para cantidades y aceites recomendados. En la tabla 2, se encuentran las cargas radiales y axiales admitidas por el reductor.

B3	B6	B7	B8	V5	V6	V8
4.50 LT	8.00 LT	5.50 LT	6.00 LT	10.00 LT	7.50 LT	Ask
SHELL Omala S2 GX 460				ENI Blasias 460		

For all details on lubrication and plugs check our website
Per maggiori dettagli su lubrificazione e tappi olio vedi il nostro sito web **tab. 1**

RADIAL AND AXIAL LOADS

Output shaft
Albero di uscita

$F_{eq} = F_R \cdot \frac{117}{X+57}$

n_2	FA	FR	n_2	FA	FR	n_2	FA	FR
300	2300	11500	140	2980	14900	70	3660	18300
250	2480	12400	120	3180	15900	40	4220	21100
200	2680	13400	85	3440	17200	15	4820	24100

Input shaft
Albero in entrata

n_1	FA	FR
1400	1120	5600
900	1220	6100
500	1300	6500

tab. 2

P1002**S9**... With foot
Con piedino

Gearbox weight 120.0 kg
peso riduttore

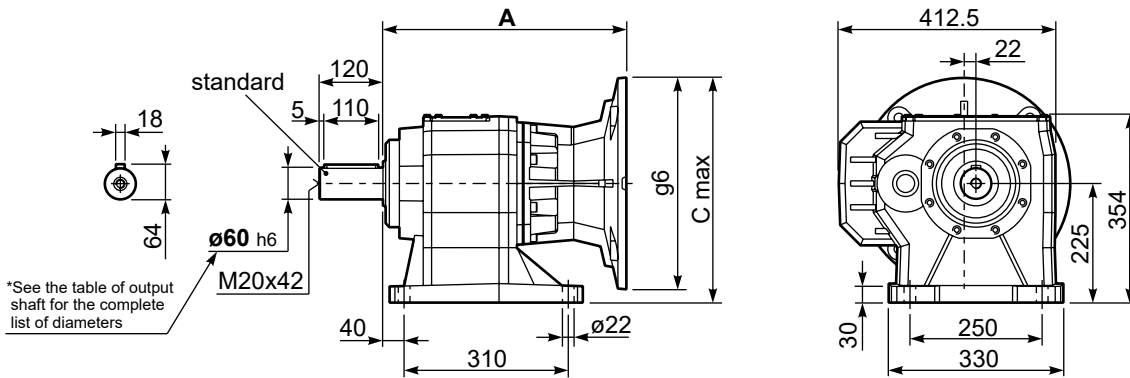

P1002-**F**... Output flanges
flange di uscita

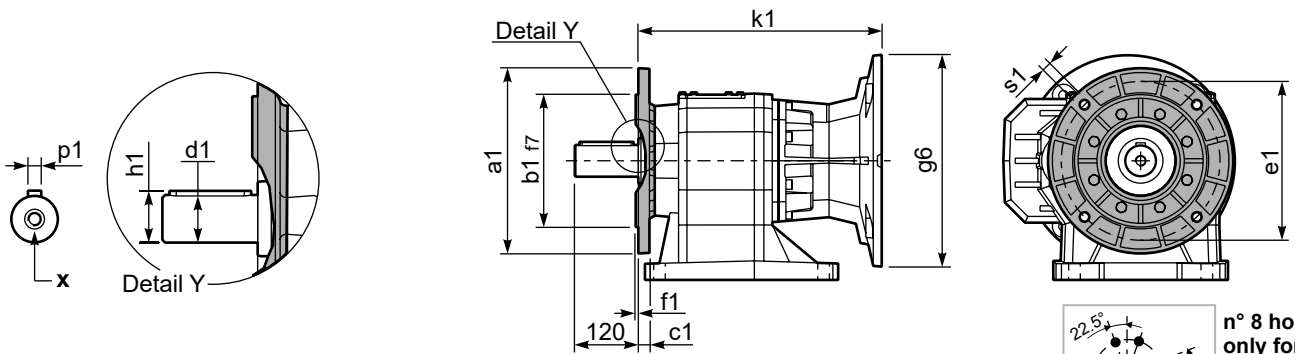

*Available output shaft / Albero di uscita

	Shaft - d1	p1	h1	x
Standard	ø 60x120	18	64	M20x42
On request A richiesta	-	-	-	-

Available output flanges / flange di uscita

a1 ø	b1	c1	e1	f1	s1	kit code
300	230	21	265	4	14	KC90.9.014
350	250	21	300	5	18	KC90.9.015
450	350	22	400	5	18	KC90.9.016

All flanges are compatible with the foot

P1002**S9**... Basic gearbox
Riduttore base

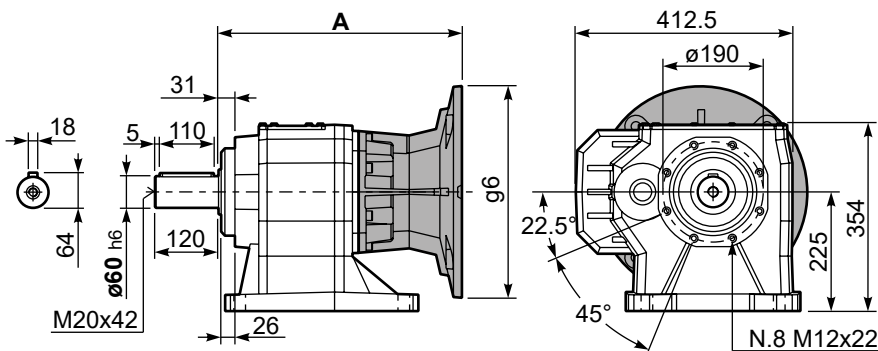

B5 Motor Flanges	A	C _{max}	g6	k1	kit code
132 B5	435	375	300	435	KC110.9.052
160 B5	460	400	350	460	KC110.9.053
180 B5	460	400	350	460	KC110.9.053_B
200 B5	460	425	400	460	KC110.9.054

R1002**S9**... Input Shaft
Albero in entrata

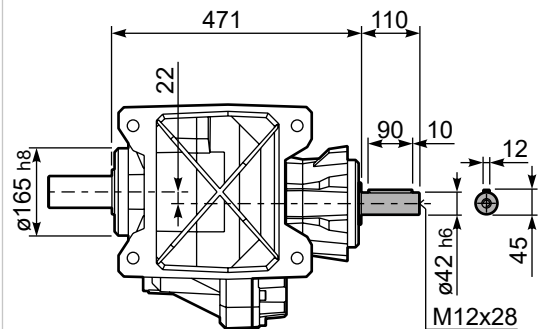

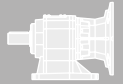

QUICK SELECTION / Selezione veloce

input speed (n_1) = 1400 min⁻¹

Output Speed n_2 [min ⁻¹]	Ratio i	Motor power P_{1M} [kW]	Output torque M_{2M} [Nm]	Service factor f.s.	Nominal power P_{1R} [kW]	Nominal torque M_{2R} [Nm]	B5 motor flanges			B14 motor flanges		Output Shaft standard ø60	Ratios code
							-F	-G	-H	-U	-V		
							100 112	132	160	100 112	132		
38.8	36.11	11	2447	1.2	12.5	2900					301411	01	
27.5	50.89	9	2941	1.0	9.2	3000					201414	02	
25.1	55.73	7.5	2591	1.2	8.4	3000					201413	03	
20.3	68.80	7.5	3199	0.9	6.8	3000					161414	04	
18.6	75.35	5.5	2589	1.2	6.2	3000					161413	05	
15.6	89.47	5.5	3074	1.0	5.2	3000					131414	06	
15.2	92.02	5.5	3161	0.9	5.1	3000					161411	07	
14.3	97.99	4	2462	1.2	4.8	3000					131413	08	
12.8	109.52	4	2752	1.1	4.3	3000					111414	09	
11.7	119.94	4	3014	1.0	3.9	3000					111413	10	
9.6	146.47	3	2771	1.1	3.2	3000					111411	11	
8.8	158.37	3	2996	1.0	3.0	3000					81414	12	
8.1	173.45	2.2	2416	1.2	2.7	3000					81413	13	
6.6	211.82	2.2	2951	1.0	2.2	3000					81411	14	

The dynamic efficiency is **0.94** for all ratios

Motor Flanges Available
Flange Motore Disponibili

B) Supplied with Reduction Bushing
Fornito con Bussola di Riduzione

B) Available on Request without reduction bushing
Disponibile a Richiesta senza Bussola di Riduzione

C) Motor Flange Holes Position
Posizione Fori Flangia Motore

EN Unit **1003** is supplied without lubricant and equipped with a breather, level and drain plugs. User can add mineral oil keeping existing plugs. Should the user wish to fill it with synthetic oil, it is recommended to replace the existing plugs with a closed plug.
See table 1 for lubrication and recommended quantity.
In table 2 please see possible radial loads and axial loads on the gearbox.

I Il riduttore tipo **1003** è fornito privo di lubrificazione con tappi di sfiato, livello e scarico olio. L'utente può immettere olio minerale mantenendo i tappi esistenti. Se immetterà olio sintetico, dovrà sostituire i tappi esistenti con altri tipo chiuso.
Tab.1 per oli e quantità consigliati.
Tab.2 carichi radiali e assiali applicabili al riduttore.

D Das Getriebe der Baugröße **1003** wird ohne Schmiermittel geliefert. Es ist jedoch mit Einfüllschraube, Überdruckventil und Ablassschraube ausgerüstet. Das benötigte mineralische Öl kann über die Einfüllschraube eingefüllt werden. Sollte synthetisches Öl bevorzugt werden, so ist sind das eingebaute Überdruckventil durch eine geschlossenen Schraube zu ersetzen.
In Tabelle 1 ist die Schmiermenge und das empfohlene Schmiermittel angegeben
In Tabelle 2 sind die zulässigen Radial - und Axialbelastungen des Getriebes aufgeführt.

F Le réducteur de type **1003** est fourni sans lubrification et avec un bouchon de remplissage, de niveau et d'évacuation de l'huile. L'utilisateur peut y verser de l'huile minérale en conservant les bouchons existants. S'il y versera de l'huile synthétique, il devra substituer les bouchons existants avec d'autres bouchons de type fermé.
Voir tableau 1 concernant les huiles et les quantités conseillées.
Voir tableau 2 concernant les charges radiales et axiales applicables au réducteur

E El reductor tamaño **1003** se suministra sin lubricante, provisto de tapones de respiración, nivel y descarga de aceite. El usuario puede utilizar aceite mineral, manteniendo los tapones existentes. Si prefiere utilizar aceite sintético deberá sustituir los tapones existentes por tapones ciegos. La prerreducción se suministra con tapones ciegos, lubricado de por vida con aceite sintético.
Ver tabla 1, para cantidades y aceites recomendados.
En la tabla 2, se encuentran las cargas radiales y axiales admitidas por el reductor.

B3	B6	B7	B8	V5	V6	V8
5.00 LT	9.00 LT	6.50 LT	6.50 LT	11.00 LT	9.00 LT	Ask
SHELL Omala S2 GX 460				ENI Blasias 460		

For all details on lubrication and plugs check our website [tab. 1](#)
Per maggiori dettagli su lubrificazione e tappi olio vedi il nostro sito web

RADIAL AND AXIAL LOADS

Output shaft
Albero di uscita

$F_{eq} = F_R \cdot \frac{117}{X+57}$

n_2	FA	FR	n_2	FA	FR	n_2	FA	FR
300	2300	11500	140	2980	14900	70	3660	18300
250	2480	12400	120	3180	15900	40	4220	21100
200	2680	13400	85	3440	17200	15	4820	24100

Input shaft
Albero in entrata

n_1	FA	FR
1400	700	3500
900	840	4200
500	900	4500

tab. 2

P1003**S9**... With foot
Con piedino

Gearbox weight **116 kg**
peso riduttore

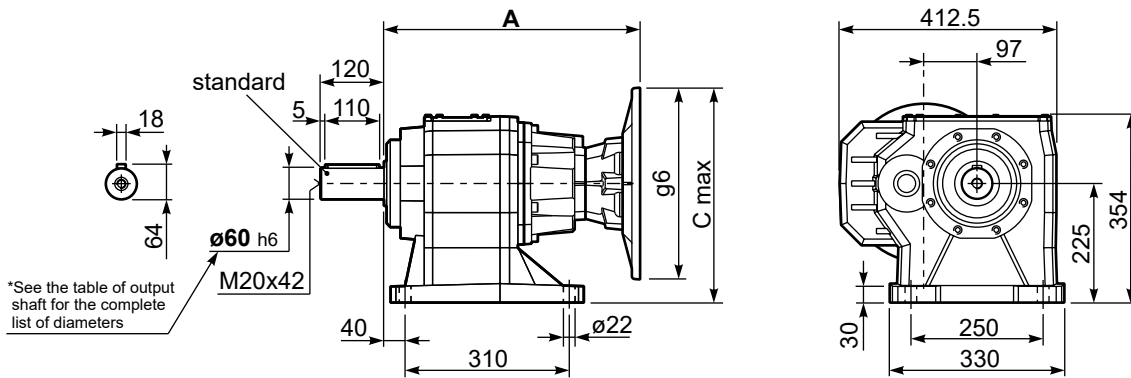

*See the table of output shaft for the complete list of diameters

P1003-**F**... Output flanges
flange di uscita

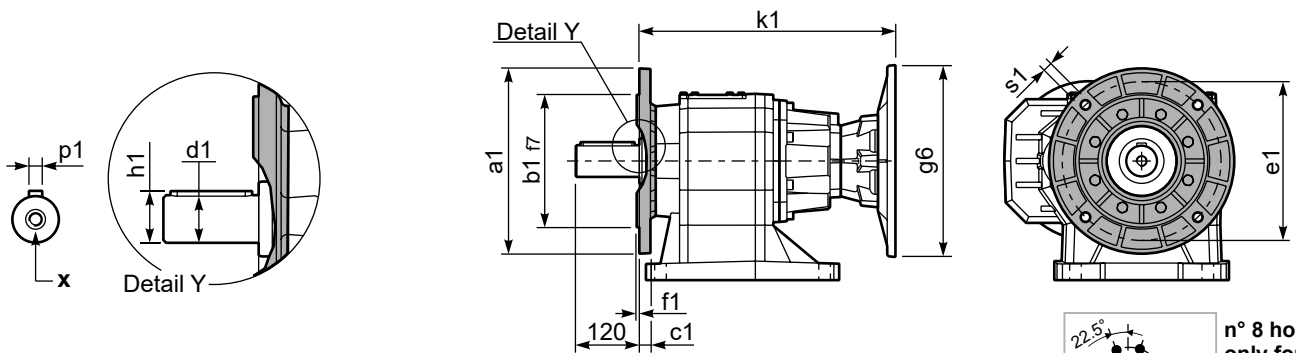

n° 8 holes only for Kit KC909016
Solo per il kit KC909016

*Available output shaft / Albero di uscita

	Shaft - d1	p1	h1	x
Standard	ø 60x120	18	64	M20x42
On request A richiesta	-	-	-	-

Available output flanges / flange di uscita

a1 ø	b1	c1	e1	f1	s1	kit code
300	230	21	265	4	14	KC90.9.014
350	250	21	300	5	18	KC90.9.015
450	350	22	400	5	18	KC90.9.016

All flanges are compatible with the foot

P1003**S9**... Basic gearbox
Riduttore base

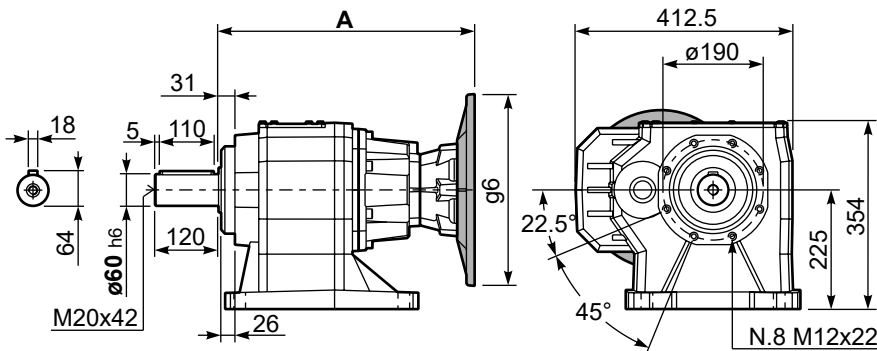

Motor Flanges	A	C _{max}	g6	k1	kit code
100/112 B5	427.5	350	250	427.5	K023.4.043
132 B5	448.5	375	300	449	KC51.4.043C
160 B5	481	400	350	481	KC86.4.043
100/112B14	427.5	305	160	427.5	K085.4.047
132B14	448.5	325	200	449	KC51.4.041C

R1003**S9**... Input Shaft
Albero in entrata

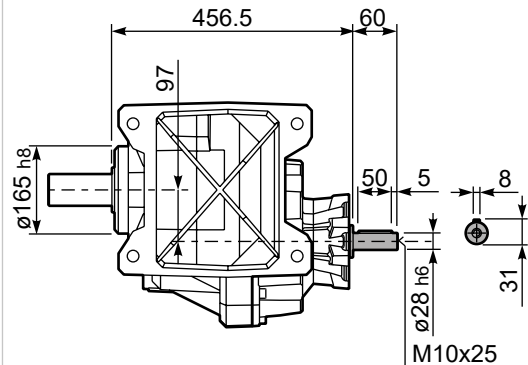

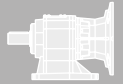

QUICK SELECTION / Selezione veloce

input speed (n_1) = 1400 min⁻¹

Output Speed n_2 [min ⁻¹]	Ratio i	Motor power P_{1M} [kW]	Output torque M_{2M} [Nm]	Service factor $f.s.$	Nominal power P_{1R} [kW]	Nominal torque M_{2R} [Nm]	B5 motor flanges					B14 motor flanges			Output Shaft 	Ratios code
							-G	-H	-I	-L	CA	-	-	-		
							132	160	180	200	225	-	-	-		
294	4.75	45	1333	2.0	86.7	2700								3914	01	
269	5.21	45	1460	1.9	82.1	2800								3913	02	
220	6.36	45	1783	1.7	72.0	3000								3911	03	
188	7.45	45	2088	1.6	67.7	3300								3014	04	
172	8.15	45	2287	1.5	63.7	3400								3013	05	
141	9.96	45	2792	1.3	55.2	3600								3011	06	
120	11.69	45	3277	1.2	49.7	3800								2214	07	
109	12.80	45	3589	1.1	47.7	4000								2213	08	
90	15.63	45	4383	1.0	42.0	4300								2211	09	
79	17.65	37	4068	1.1	38.9	4500								1614	10	
72	19.33	37	4455	1.0	35.6	4500								1613	11	
67	20.77	30	3910	1.2	33.1	4500								1414	12	
62	22.75	30	4282	1.1	30.2	4500								1413	13	
59	23.60	30	4443	1.0	29.1	4500								1611	14	
50	27.78	22	3842	1.2	24.7	4500								1411	15	
45.5	30.76	22	4255	1.1	22.3	4500								1014	16	
41.6	33.69	22	4660	1.0	20.4	4500								1013	17	
34.0	41.15	18.5	4781	0.9	16.7	4500								1011	18	

The dynamic efficiency is **0.96** for all ratios

Motor Flanges Available
Flange Motore Disponibili

B) Supplied with Reduction Bushing
Fornito con Bussola di Riduzione

B) Available on Request without reduction bushing
Disponibile a Richiesta senza Bussola di Riduzione

C) Motor Flange Holes Position
Posizione Fori Flangia Motore

EN Unit 1102 is supplied without lubricant and equipped with a breather, level and drain plugs. User can add mineral oil keeping existing plugs. Should the user wish to fill it with synthetic oil, it is recommended to replace the existing plugs with a closed plug.
See table 1 for lubrication and recommended quantity. In table 2 please see possible radial loads and axial loads on the gearbox.

I Il riduttore tipo 1102 è fornito privo di lubrificazione con tappi di sfiato, livello e scarico olio. L'utente può immettere olio minerale mantenendo i tappi esistenti. Se immetterà olio sintetico, dovrà sostituire i tappi esistenti con altri tipo chiuso.
Tab.1 per oli e quantità consigliati.
Tab.2 carichi radiali e assiali applicabili al riduttore.

D Das Getriebe der Baugröße 1102 wird ohne Schmiermittel geliefert. Es ist jedoch mit Einfüllschraube, Überdruckventil und Ablassschraube ausgerüstet. Das benötigte mineralische Öl kann über die Einfüllschraube eingefüllt werden. Sollte synthetisches Öl bevorzugt werden, so ist sind das eingebaute Überdruckventil durch eine geschlossenen Schraube zu ersetzen.
In Tabelle 1 ist die Schmiermenge und das empfohlene Schmiermittel angegeben
In Tabelle 2 sind die zulässigen Radial - und Axialbelastungen des Getriebes aufgeführt.

F Le réducteur de type 1102 est fourni sans lubrification et avec un bouchon de remplissage, de niveau et d'évacuation de l'huile. L'utilisateur peut y verser de l'huile minérale en conservant les bouchons existants. S'il y versera de l'huile synthétique, il devra substituer les bouchons existants avec d'autres bouchons de type fermé.
Voir tableau 1 concernant les huiles et les quantités conseillées.
Voir tableau 2 concernant les charges radiales et axiales applicables au réducteur

E El reductor tamaño 1102 se suministra sin lubricante, provisto de tapones de respiración, nivel y descarga de aceite. El usuario puede utilizar aceite mineral, manteniendo los tapones existentes. Si prefiere utilizar aceite sintético deberá sustituir los tapones existentes por tapones ciegos. La prerreducción se suministra con tapones ciegos, lubricado de por vida con aceite sintético. Ver tabla 1, para cantidades y aceites recomendados. En la tabla 2, se encuentran las cargas radiales y axiales admitidas por el reductor.

B3	B6	B7	B8	V5	V6	V8
6.50 LT	12.50 LT	7.50 LT	8.50 LT	14.50 LT	11.50 LT	Ask
SHELL Omala S2 GX 460				ENI Blasias 460		

For all details on lubrication and plugs check our website
Per maggiori dettagli su lubrificazione e tappi olio vedi il nostro sito web **tab. 1**

RADIAL AND AXIAL LOADS								
Output shaft Albero di uscita			$F_{eq} = F_R \cdot \frac{138}{X+68}$					
n_2	FA	FR	n_2	FA	FR	n_2	FA	FR
300	2600	13000	140	3300	16500	70	4300	21500
250	2700	13500	120	3500	17500	40	5000	25000
200	3000	15000	85	3900	19500	15	5900	29500
Input shaft Albero in entrata								
n_1	FA	FR						
1400	1120	5600						
900	1220	6100						
500	1300	6500						

tab. 2

P1102**S0**... With foot
Con piedino

Gearbox weight
peso riduttore **165 kg**

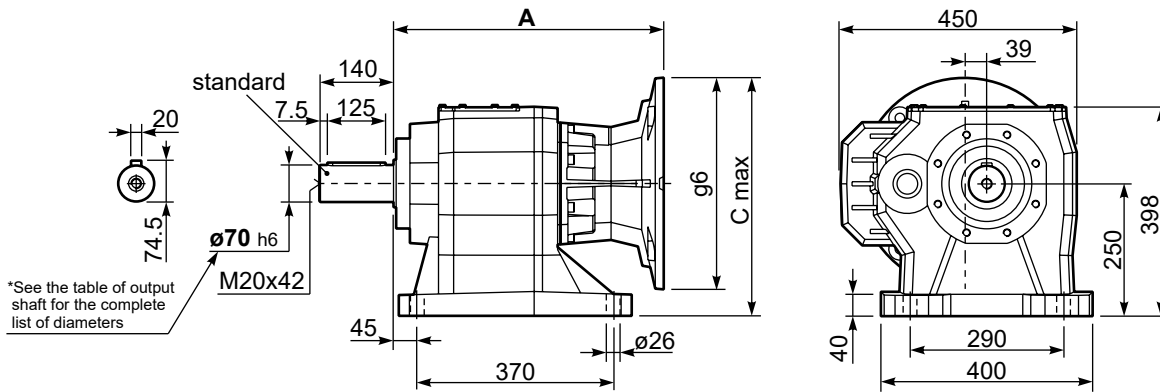

P1102-**F**... Output flanges
flange di uscita

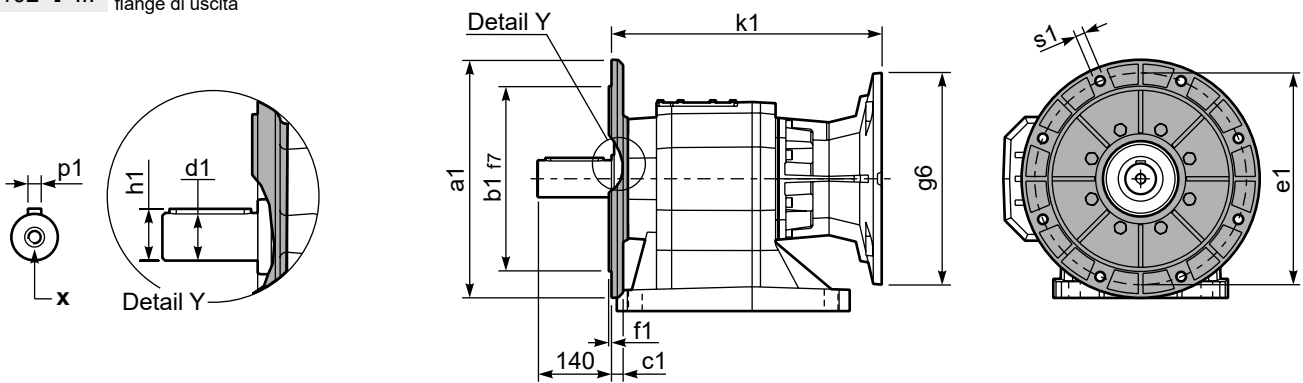

*Available output shaft / Albero di uscita

	Shaft - d1	p1	h1	x
Standard	ø 70x140	20	74.5	M20x42
On request A richiesta	-	-	-	-

Available output flanges / flange di uscita

a1 ø	b1	c1	e1	f1	s1	kit code
350	250	21	300	5	18	KC110.9.015
450	350	22	400	5	18	KC110.9.016
-	-	-	-	-	-	-

All flanges are compatible with the foot

P1102**S0**... Basic gearbox
Riduttore base

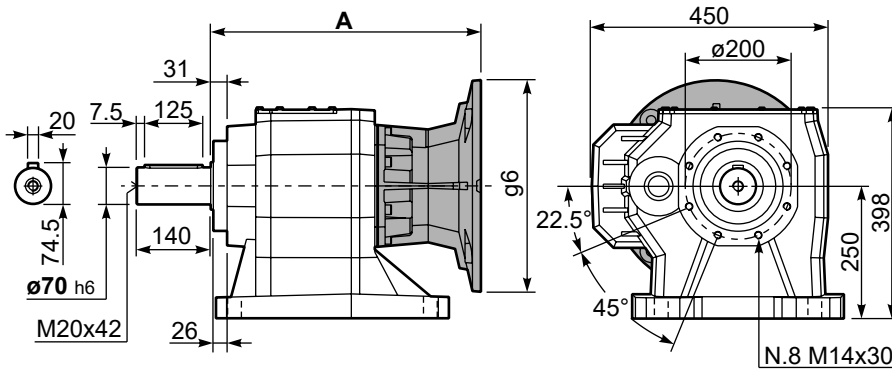

B5 Motor Flanges	A	C _{max}	g6	k1	kit code
132 B5	485.5	400	300	485.5	KC110.9.052
160 B5	510.5	425	350	510.5	KC110.9.053
180 B5	510.5	425	350	510.5	KC110.9.053 B
200 B5	510.5	450	400	510.5	KC110.9.054
225 B5	537.5	475	450	537.5	KC110.9.055

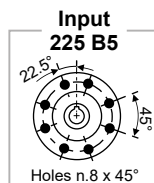

R1102**S0**... Input Shaft
Albero in entrata

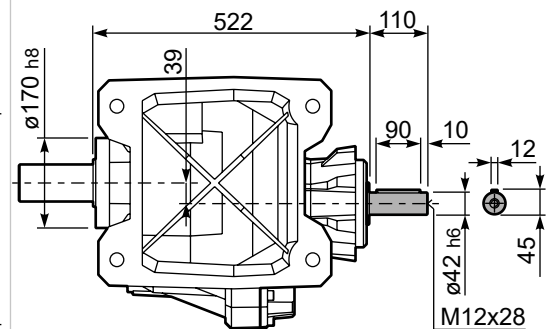

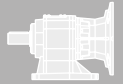

QUICK SELECTION / Selezione veloce

input speed (n_1) = 1400 min⁻¹

Output Speed n_2 [min ⁻¹]	Ratio i	Motor power P_{1M} [kW]	Output torque M_{2M} [Nm]	Service factor f.s.	Nominal power P_{1R} [kW]	Nominal torque M_{2R} [Nm]	Available B5 motor flanges				B14 motor flanges		Output Shaft standard ø70	Ratios code
							-F	-G	-H	-I	-U	-V		
							100 112	132	160	180	100 112	132		
38.8	36.11	18.5	4113	1.1	19.4	4500						301411	01	
27.5	50.89	15	4694	1.0	14.1	4600						201414	02	
25.1	55.73	11	3777	1.2	12.9	4600						201413	03	
20.3	68.80	11	4662	1.0	10.4	4600						161414	04	
18.6	75.35	9	4354	1.1	9.5	4600						161413	05	
15.6	89.47	7.5	4160	1.1	8.0	4600						131414	06	
15.2	92.02	7.5	4278	1.1	7.6	4500						161411	07	
14.3	97.99	7.5	4556	1.0	7.3	4600						131413	08	
12.8	109.52	5.5	3762	1.2	6.6	4600						111414	09	
11.7	119.94	5.5	4120	1.1	6.0	4600						111413	10	
9.6	146.47	4	3681	1.2	4.8	4500						111411	11	
8.8	158.37	4	3980	1.2	4.5	4600						81414	12	
8.1	173.45	4	4359	1.1	4.1	4600						81413	13	
6.6	211.82	3	4007	1.1	3.3	4500						81411	14	

The dynamic efficiency is **0.94** for all ratios

Motor Flanges Available
Flange Motore Disponibili

B) Supplied with Reduction Bushing
Fornito con Bussola di Riduzione

B) Available on Request without reduction bushing
Disponibile a Richiesta senza Bussola di Riduzione

C) Motor Flange Holes Position
Posizione Fori Flangia Motore

EN Unit 1103 is supplied without lubricant and equipped with a breather, level and drain plugs. User can add mineral oil keeping existing plugs. Should the user wish to fill it with synthetic oil, it is recommended to replace the existing plugs with a closed plug.
See table 1 for lubrication and recommended quantity.
In table 2 please see possible radial loads and axial loads on the gearbox.

I Il riduttore tipo 1103 è fornito privo di lubrificazione con tappi di sfiato, livello e scarico olio. L'utente può immettere olio minerale mantenendo i tappi esistenti. Se immetterà olio sintetico, dovrà sostituire i tappi esistenti con altri tipo chiuso.
Tab.1 per oli e quantità consigliati.
Tab.2 carichi radiali e assiali applicabili al riduttore.

D Das Getriebe der Baugröße 1103 wird ohne Schmiermittel geliefert. Es ist jedoch mit Einfüllschraube, Überdruckventil und Ablassschraube ausgerüstet. Das benötigte mineralische Öl kann über die Einfüllschraube eingefüllt werden. Sollte synthetisches Öl bevorzugt werden, so ist sind das eingebaute Überdruckventil durch eine geschlossenen Schraube zu ersetzen.
In Tabelle 1 ist die Schmiermenge und das empfohlene Schmiermittel angegeben
In Tabelle 2 sind die zulässigen Radial - und Axialbelastungen des Getriebes aufgeführt.

F Le réducteur de type 1103 est fourni sans lubrification et avec un bouchon de remplissage, de niveau et d'évacuation de l'huile. L'utilisateur peut y verser de l'huile minérale en conservant les bouchons existants. S'il y versera de l'huile synthétique, il devra substituer les bouchons existants avec d'autres bouchons de type fermé.
Voir tableau 1 concernant les huiles et les quantités conseillées.
Voir tableau 2 concernant les charges radiales et axiales applicables au réducteur

E El reductor tamaño 1103 se suministra sin lubricante, provisto de tapones de respiración, nivel y descarga de aceite. El usuario puede utilizar aceite mineral, manteniendo los tapones existentes. Si prefiere utilizar aceite sintético deberá sustituir los tapones existentes por tapones ciegos. La prerreducción se suministra con tapones ciegos, lubricado de por vida con aceite sintético. Ver tabla 1, para cantidades y aceites recomendados. En la tabla 2, se encuentran las cargas radiales y axiales admitidas por el reductor.

B3	B6	B7	B8	V5	V6	V8
7.00 LT	13.00 LT	8.00 LT	9.00 LT	16.00 LT	13.50 LT	Ask
SHELL Omala S2 GX 460				ENI Blasias 460		

For all details on lubrication and plugs check our website **tab. 1**
Per maggiori dettagli su lubrificazione e tappi olio vedi il nostro sito web

RADIAL AND AXIAL LOADS								
Output shaft Albero di uscita			$F_{eq} = FR \cdot \frac{138}{X+68}$					
n_2	FA	FR	n_2	FA	FR	n_2	FA	FR
300	2600	13000	140	3300	16500	70	4300	21500
250	2700	13500	120	3500	17500	40	5000	25000
200	3000	15000	85	3900	19500	15	5900	29500
Input shaft Albero in entrata								
n_1	FA	FR						
1400	700	3500						
900	840	4200						
500	900	4500						

tab. 2

P1103**S0**... With foot
Con piedino

Gearbox weight **156 kg**
peso riduttore

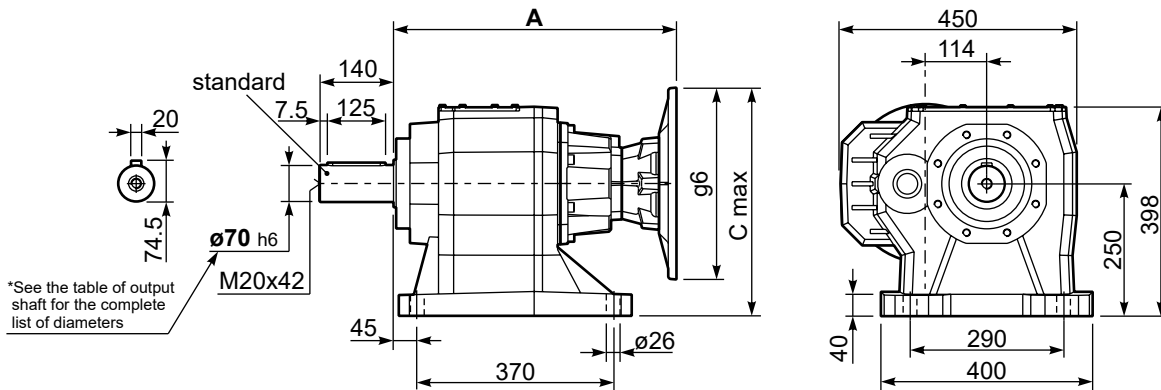

*See the table of output shaft for the complete list of diameters

P1103-**F**... Output flanges
flange di uscita

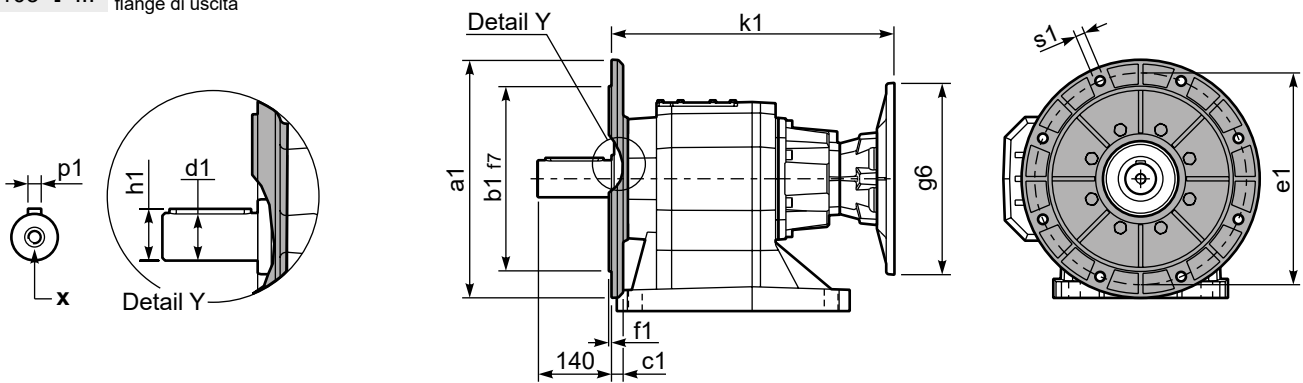

*Available output shaft / Albero di uscita

	Shaft - d1	p1	h1	x
Standard	ø 70x140	20	74.5	M20x42
On request A richiesta	-	-	-	-

Available output flanges / flange di uscita

a1 ø	b1	c1	e1	f1	s1	kit code
350	250	21	300	5	18	KC110.9.015
450	350	22	400	5	18	KC110.9.016
-	-	-	-	-	-	-

All flanges are compatible with the foot

P1103**S0**... Basic gearbox
Riduttore base

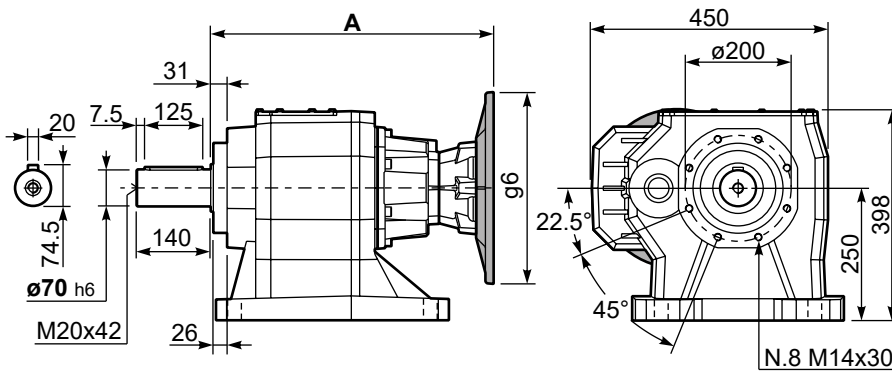

Motor Flanges	A	C _{max}	g6	k1	kit code
100/112 B5	478	375	250	478	K023.4.043
132 B5	499.5	400	300	499.5	KC51.4.043C
160-180 B5	531.5	425	350	531.5	KC864.043
100/112B14	478	330	160	478	K085.4.047
132B14	499.5	350	200	499.5	KC51.4.041C

R1103**S0**... Input Shaft
Albero in entrata

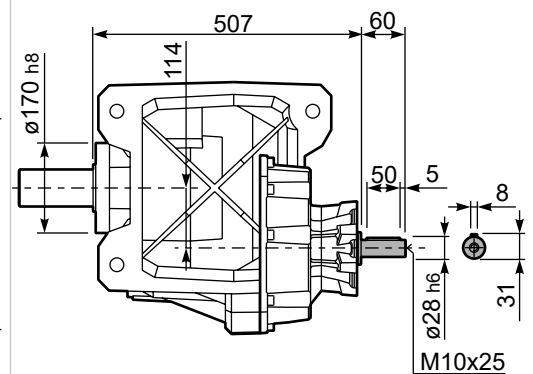

Aluminum & cast iron shaft mounted gearboxes

A modular and compact product

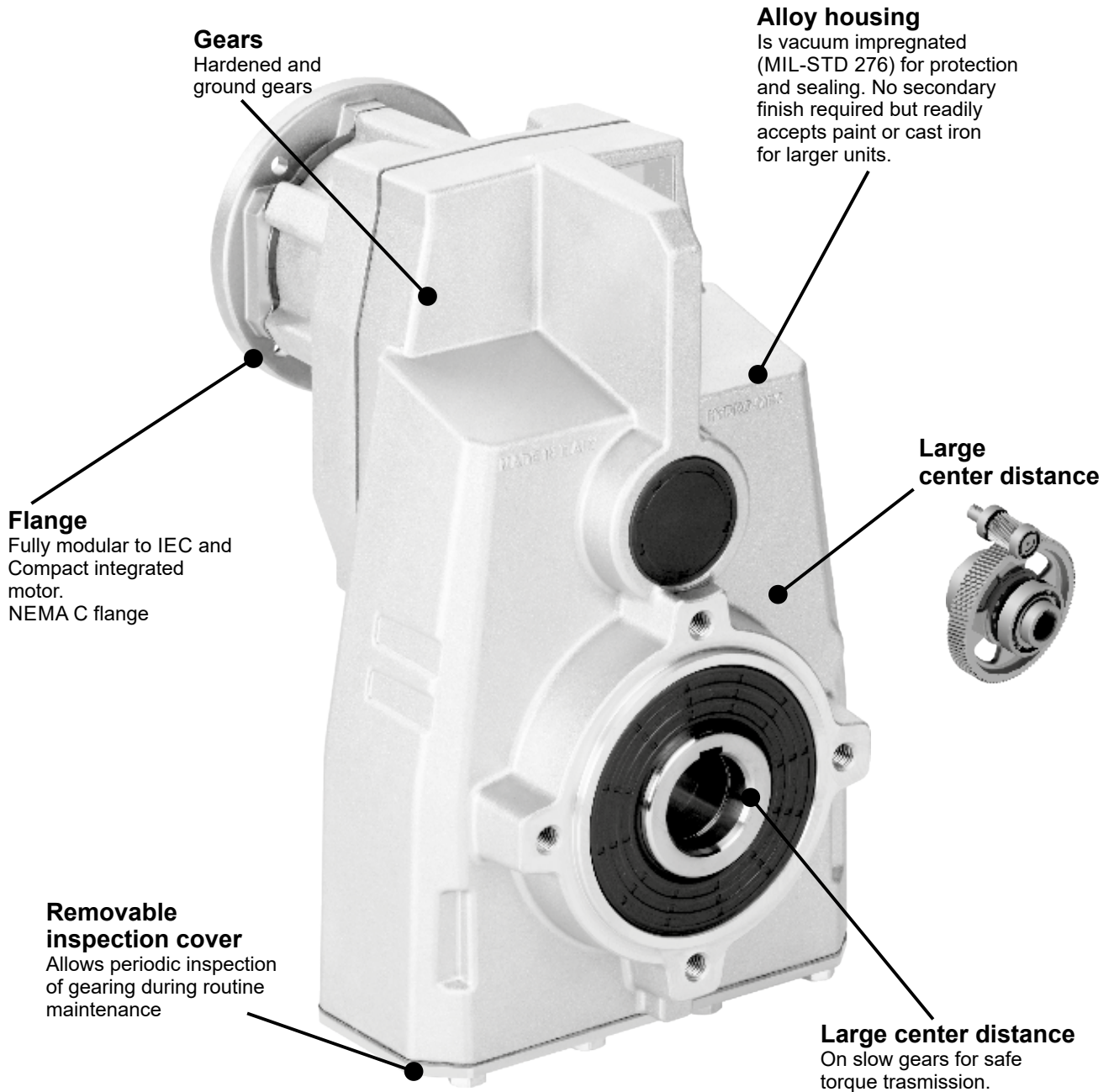

7

Single-piece aluminum / Cast Iron housing

Combines light weight with high tensile strength. Precision machined for alignment of bearings and gearing

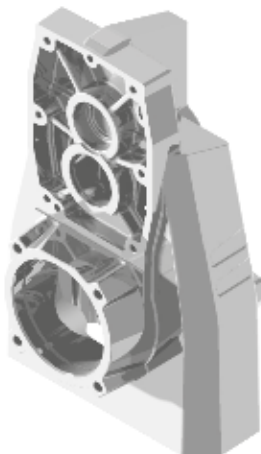
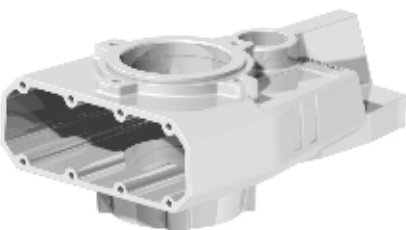

Painting

Cast iron gearboxes are painted RAL 7046

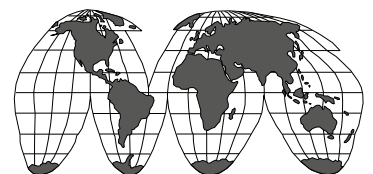

World wide sales network.

Specific type datasheet on page...

On page / A pagina / Auf Seite / À la page / En la página

3 Stage

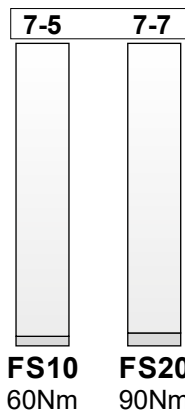

Types / Tipi /
Tipen / Types /
Tipos

On page / A pagina / Auf Seite / À la page / En la página

1 Stage

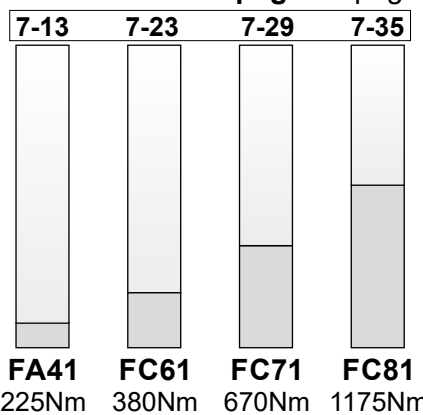
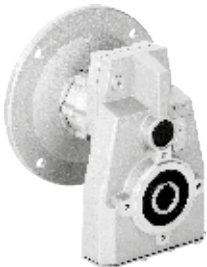

Types / Tipi /
Tipen / Types /
Tipos

On page / A pagina / Auf Seite / À la page / En la página

2 and 3 Stage

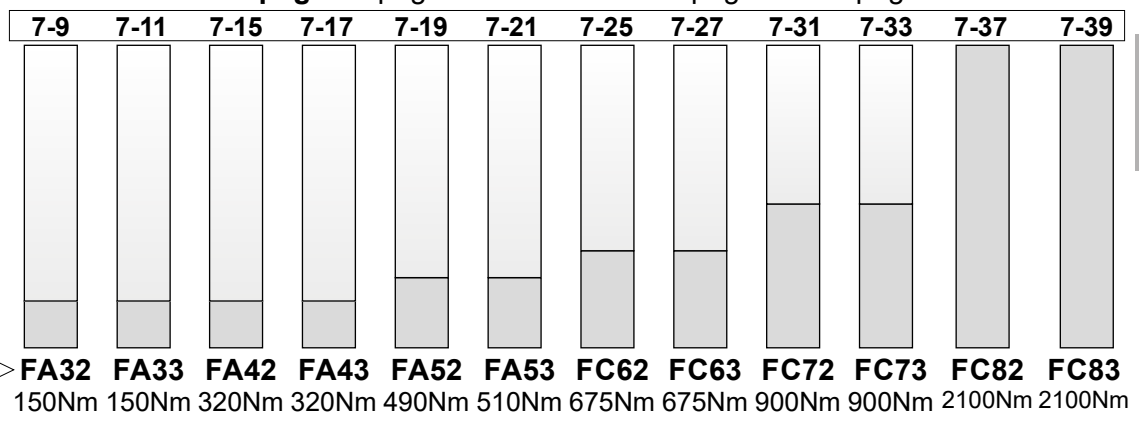





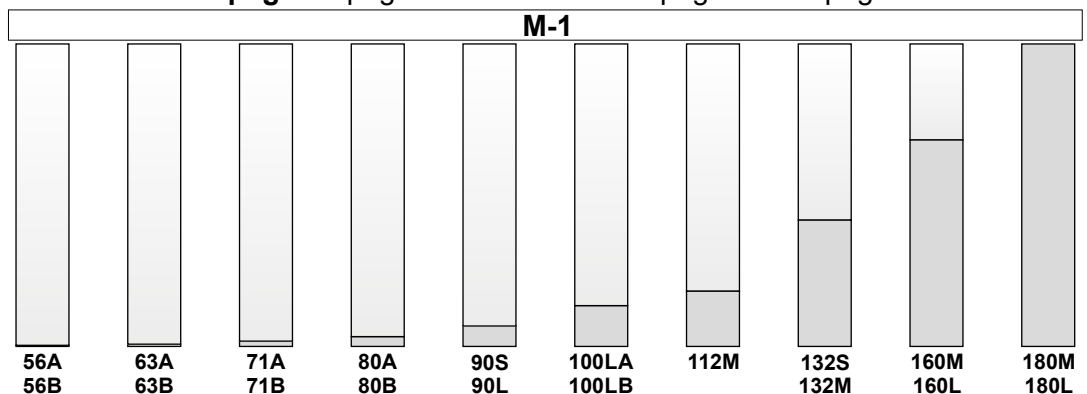
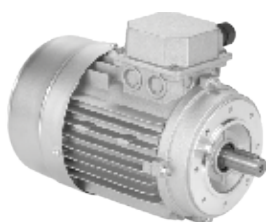



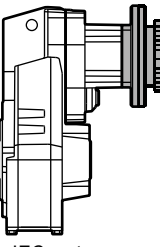
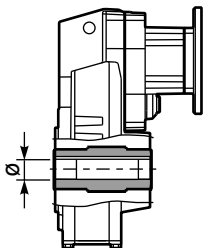
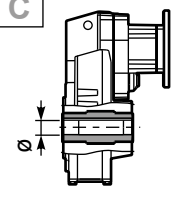
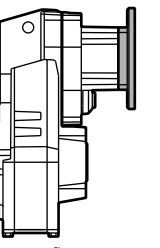
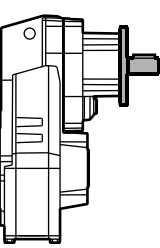
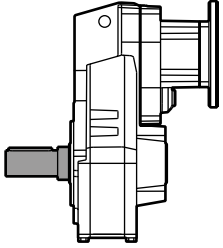
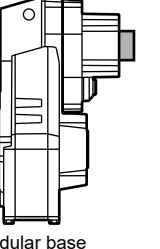
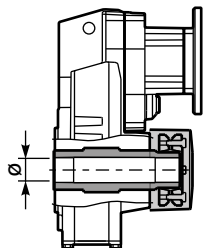
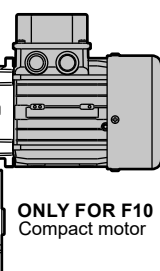
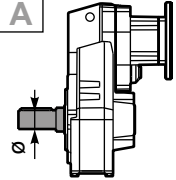

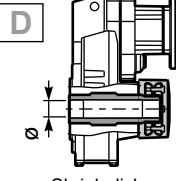

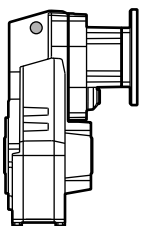
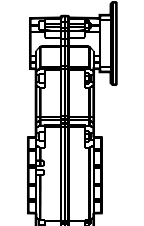
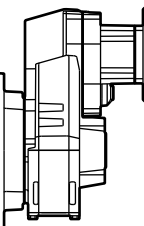
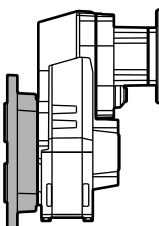
Types / Tipi /
Tipen / Types /
Tipos

On page / A pagina / Auf Seite / À la page / En la página

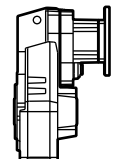
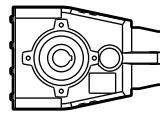
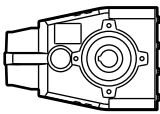
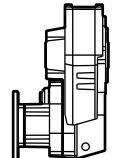
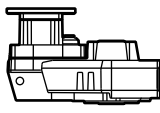
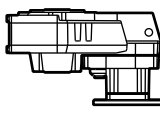
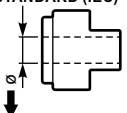

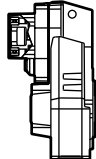
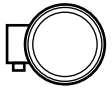
Types / Tipi /
Tipen / Types /
Tipos

Type - Tipo - Typ Type - Tipo	Size - Grandezza - Grösse Taille - Tamaño	Mounting - Montaggio Montage - Fixation Tipo de montaje	Rapporto - Ratio Untersetzung Reduction - Relacion	Output shaft Albero uscita Abtriebswelle Arbre de sortie Eje en salida
<p>M</p> <p>Shaft mounted helical Riduttori ad assi paralleli</p>  <p>With IEC motor</p> <p>M</p>	<p>FA42</p> <p>1 Stage Riduzione Stufe Trains Etapas</p> <p>2 Stages Riduzioni Stufen Trains Etapas</p> <p>3 Stages Riduzioni Stufen Trains Etapas</p>	<p>C</p>	<p>10.04</p>	<p>-D</p>
	<p>Aluminum/Alluminio/Aluminium/Aluminio</p>	 <p>Hollow output shaft</p> <p>C</p>	<p>See technical data table</p> <p>Vedi tabelle dati tecnici.</p> <p>Technisches Datenblatt beachten</p> <p>Voir Tableau données techniques</p> <p>Ver tabla datos técnicos</p>	 <p>C</p>
 <p>With motor flange</p> <p>P</p>	<p>FA41</p>	<p>FS10</p> <p>FS20</p>		<p>→ STANDARD</p> <p>→ Only on request for Q.ty A richiesta per quantità</p> <p>FS10</p> <p>-J → ø17</p> <p>FS20</p>
 <p>With male input shaft</p> <p>R</p>	<p>FA32</p> <p>FA42</p> <p>FA52</p>	 <p>Single output shaft</p> <p>A</p>		<p>-B → ø20</p> <p>FA32-3</p> <p>-C → ø25</p> <p>FA41 FA42 FA43</p> <p>-C → ø25</p> <p>-D → ø30</p> <p>-E → ø35</p>
 <p>Modular base</p> <p>B</p> <p>Not available for: FC61, FC71, FC81, FC82.</p>	<p>Cast Iron/Ghisa/Grauguss/Fonte/Fundicion</p> <p>FC61</p> <p>FC71</p> <p>FC81</p>	 <p>Shrink Disk</p> <p>D</p> <p>Only on request for Q.ty A richiesta per quantità</p>		<p>FA52 FA53 FC61 FC62 FC63</p> <p>-E → ø35</p> <p>-F → ø40</p> <p>FC71 FC72 FC73</p> <p>-F → ø40</p> <p>-G → ø45</p> <p>FC81 FC82 FC83</p> <p>-H → ø50</p> <p>-I → ø55</p>
 <p>ONLY FOR F10 Compact motor</p> <p>C</p>	<p>FC62</p> <p>FC72</p> <p>FC82</p>	<p>FC63</p> <p>FC73</p> <p>FC83</p>		 <p>Single output shaft</p> <p>-L FA32/3 → ø25</p> <p>-M FA41/2/3 → ø30</p> <p>FA52/3</p> <p>-N FC61/2/3 → ø35</p> <p>-O FC71/2/3 → ø40</p> <p>-K FC81/2/3 → ø50</p>
<p>7-1</p>	 <p>On request we can deliver our products according to the ATEX A richiesta possiamo fornire i nostri prodotti secondo le normative ATEX Auf Anfrage können wir unsere Produkte den Richtlinien ATEX entsprechend liefern Sur demande nos produits peuvent se conformer à la réglementation ATEX A pedido, se pueden enviar nuestros productos de acuerdo con las normas ATEX.</p>	 <p>Shrink disk</p> <p>-Q FA42/3 → ø30</p> <p>-T FA52/3 FC62/3 → ø35</p> <p>-U FC72/3 → ø40</p> <p>-V FC82/3 → ø50</p>		

Type - Tipo - Typ Types - Tipo	Output flange Flangia uscita Ausgangsflansch Bride de sortie Brida en salida	Motor size - Grandezza motore Motor Grösse Grandeur moteur - Tamaño motor	Mounting position Posizione montaggio Einbaulage Position de montage Position de montaje	Input bore Foro entrata Eingangshohlwelle Trou d'entree Eje hueco de entrada	Terminal box position Posizione morsettieria Klemmkastenlage Position boîte à bornes Posición caja de bornes
<p>ST</p>  <p>ST Foro standard Standard bore</p>  <p>only for FS10 / FS20</p> <p>ST Senza braccio di reazione Without reaction arm</p>  <p>-F Whit output flange con flangia uscita</p>	<p>N</p>  <p>N Senza flangia Without flange</p> <p>FS20</p> <p>1 → ∅140</p> <p>FA32-3 FA41-2-3</p> <p>2 → ∅160</p> <p>3 → ∅200</p> <p>4 → ∅250</p> <p>FA52 FA53 FC61 FC62 FC63</p> <p>4 → ∅250</p> <p>FC71 FC72 FC73</p> <p>4 → ∅250</p> <p>5 → ∅300</p> <p>FC81 FC82 FC83</p> <p>5 → ∅300</p> <p>6 → ∅350</p>	<p>-C</p> <p>Flange Flangia</p>  <p>B5</p> <p>-A=56 (∅120)</p> <p>-B=63 (∅140)</p> <p>-C=71 (∅160)</p> <p>-D=80 (∅200)</p> <p>-E=90 (∅200)</p> <p>-F=100 (∅250)</p> <p>-G=132 (∅300)</p> <p>-H=160 (∅350)</p> <p>-I=180 (∅350)</p> <p>Without flange Senza flangia</p>  <p>B14</p> <p>-O=56 (∅80)</p> <p>-P=63 (∅90)</p> <p>-Q=71 (∅105)</p> <p>-R=80 (∅120)</p> <p>-T=90 (∅140)</p> <p>-U=100 (∅160)</p> <p>-V=132 (∅200)</p> <p>Brushless</p> <p>BB=50/70-M5</p> <p>BC=60/75-M5</p> <p>BD=70/90-M6</p> <p>BE=80/100-M6</p> <p>BF=95/115-M8</p> <p>BG=110/145-M8</p> <p>BH=130/165-M8</p> <p>Type R Tipo R</p>  <p>FA33 FA43 FS10 FS20</p> <p>-1 → ∅14</p> <p>FA32 FA42 FA53 FC63 FC73</p> <p>-2 → ∅19</p> <p>FA52 FC62 FC72 FC83</p> <p>-3 → ∅24</p> <p>FC82</p> <p>-4 → ∅28</p> <p>With coupling</p> <p>-M → With coupling</p> <p>FA33 FA43 FS10 FS20</p> <p>-Z → ∅9 (56B5)</p> <p>-0 → ∅11 (63B5)</p> <p>-1 → ∅14 (71B5)</p> <p>FA32 FA42 FA53 FC63 FC73</p> <p>-1 → ∅14 (71B5)</p> <p>-2 → ∅19 (80B5)</p> <p>-3 → ∅24 (90B5)</p> <p>FA52 FC62 FC72 FC83</p> <p>-2 → ∅19 (80B5)</p> <p>-3 → ∅24 (90B5)</p> <p>-4 → ∅28 (100B5)</p> <p>FA41</p> <p>-4 → ∅28 (100B5)</p>	<p>H1</p>  <p>H1 STANDARD</p>  <p>H4</p>  <p>H3</p>  <p>H2</p>  <p>H5</p>  <p>H6</p>	<p>ST standard bore foro standard</p> <p>COUPLING STANDARD (IEC)</p>  <p>-A = 9mm</p> <p>-B = 11mm</p> <p>-C = 14mm</p> <p>-D = 19mm</p> <p>-E = 24mm</p> <p>-F = 28mm</p> <p>BRUSHLESS *</p>  <p>-2 = 11mm</p> <p>-3 = 14mm</p> <p>-4 = 19mm</p> <p>-5 = 22mm</p> <p>-6 = 24mm</p> <p>-0 Ready for input coupling Predisposto per giunto</p>  <p>* With reduction bushing where applicable Con bussola di riduzione dove prevista</p>	<p>With Type M specify terminal box position Con tipo M specificare posizione morsettieria</p>  <p>A</p>  <p>B STANDARD</p>  <p>C</p>  <p>D</p>

POTENZA RICHIESTA / REQUIRED POWER / ERFORDERLICHE LEISTUNG / PUISSANCE NECESSAIRE / POTENCIA NECESARIA

Lifting / sollevamento / hubantriebe / levage / elevación

$$P [KW] = \frac{M [Kg] \cdot g [9.81] \cdot v [m / s]}{1000}$$

Rotation / rotazione / drehung / rotation / rotação

$$P [KW] = \frac{M [Nm] \cdot n [rpm]}{9550}$$

Linear movement / traslazione / linearbewegung / translation / translación

$$P [KW] = \frac{F [N] \cdot v [m / s]}{1000}$$

TORQUE / COPPIA / DREHMOMENT / COUPLE / PAR

$$M [Nm] = \frac{9550 \cdot P[KW]}{n [rpm]}$$

$$M [lb in] = \frac{63030 \cdot P[HP]}{n [rpm]}$$

RADIAL LOADS / CARICHI RADIALI / RADIALE - UND AXIALLASTEN / CHARGES RADIALES / CARGA RADIAL Y AXIAL

- Radial load generated by external transmissions keyed onto input and/or output shafts.
- Forza radiale generata da organi di trasmissione calettati sugli alberi di ingresso e/o uscita.
- Belastungen der Antriebs- bzw. Abtriebswellen durch von aussen eingebrachte Radiallasten.
- Charge radiale générée par la transmissions calés sur les entrées et / ou des arbres de sortie
- Cargas radiales, generada por transmisiones externas, aplicadas sobre los ejes de entrada y/o salida

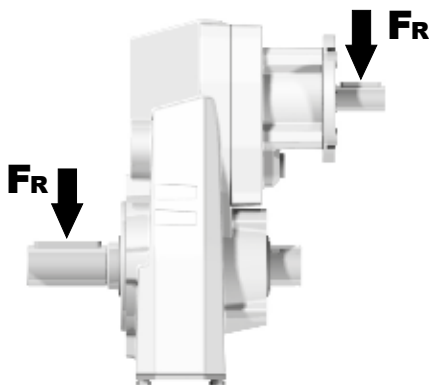

$$F_R [N] = \frac{M [Nm] \cdot 2000}{d [mm]} \cdot f_k$$

$$F_R [N] = \frac{M [lb in] \cdot 8.9}{d [in]} \cdot f_k$$

M	Momento torcente / Output torque / Abtriebsdrehmoment / Couple / Par torsion
d	Diametro primitivo / Diam. of driving element / Durchmesser der Abtriebseinheit / Diamètre primitif / Diámetro primitivo
f_k	Coefficiente di trasformazione / Factor / Faktor / Coefficient de transmission / Coeficiente de transmisión 1.15 Ingranaggi / Gearwheels / Zahnrad / Engrenage / Engranaje 1.25 Catena / Chain sprockets / Antriebskette / Chaîne / Cadena 1.75 Cinghia Trapezoidale / Narrow v-belt pulley / Keilriemen / Courroie trap. / Correa trapezoidal 2.50 Cinghia piatta / Flat-belt pulley / Flachzahnriem. / Courroie crantée / Correa plana

- If your application requires higher radial loads, contact our technical office. Higher load may be possible.
- Nel caso la vostra applicazione richieda carichi radiali superiori consultare il nostro ufficio tecnico, valori maggiori possono essere accettati.
- Wenn Ihre Anwendung höhere Radialbelastungen erfordert, so wenden Sie sich bitte an unser technischen Büro.
- Si votre application demande des charges radiales supérieures, s'adresser à notre bureau technique.
- En el caso en que una aplicación exija una carga radial superior a la especificada en el catálogo, consultar a nuestra oficinas técnica.

How to select a gearbox / Come selezionare un riduttore / Wie wählt man ein Getriebe
Comment sélectionner un réducteur / Cómo seleccionar un reductor

B Output speed
Velocità in uscita
Abtriebsdrehzahl
Vitesse de sortie
Velocidad de salida

Nominal power
Potenza nominale
Max. mögliche Leistung
Poissance nominale
Potencia nominal

A Nominal torque
Momento torcente nominale
Nenn Drehmoment
Couple nominal
Par de torsión nominal

Flange code
Codice flangia
Flanschtype
Code bride
Código bridas

Input speed
Velocità in entrata
Eintriebsdrehzahl
Vitesse en entrée
Velocidad de entrada

Gear size
Grandezza riduttore
Getriebegröße
Taille réducteur
Tamaño reductor

Motor power
Potenza motore
Motorleistung
Puissance moteur
Potencia motor

FA42 Compact-Gear

320Nm

Rating - Aluminum
SHAFT MOUNTED HELICAL

QUICK SELECTION / Selezione veloce										input speed (n ₁) = 1400 min ⁻¹							
Output Speed n ₂ [min ⁻¹]	Ratio i	Motor power P _{1M} [kW]	Output torque M _{2M} [Nm]	Service factor f.s.	Nominal power P _{1R} [kW]	Nominal torque M _{2R} [Nm]	Available B5 motor flanges					Available B14 motor flanges				Output Shaft	
							-B	-C	-D	-E	-F	-Q	-R	-T	-U		Ratio code
167	8.38	4	215	1.0	4.1	225	B					C	C			2821	01
139	10.04	3	194	1.2	3.7	240	B					C	C			2818	02
114	12.33	3	238	1.1	3.2	260	B					C	C			2813	03
92	15.16	2.2	216	1.2	2.6	260	B					C	C			1921	04

C Ratio
Rapporto
Untersetzung
Rapport de réduction
Relación

Transmitted torque
Momento torcente trasmesso
Mögliche Drehmomente
Couple de sortie
Par transmitido

Service factor
Fattore di servizio
Betriebsfaktor
Facteur de service
Factor de servicio

Output shaft diam.
Diam. albero uscita
Durchmesser abtriebswelle
Diametre arbre lent
Diametro eje de salida

Notes
Note
Anmerkungen
Note
Notas

Type of load and starts per hour Tipo di carico e avviamenti per ora		Oper. hours per day Ore di funz. giorn.		
		3 h	10 h	24 h
Continuous or intermittent appl. with start / hour Applicazione cont. o interm. con n.ro operazioni/ora	Uniform / Uniforme	0.8	1	1.25
	Moderate / Moderato	1	1.25	1.5
	Heavy / Forte	1.25	1.5	1.75
Intermittent application with start / hour Applicazione intermittente con n.ro operazioni/ora	Uniform / Uniforme	1	1.25	1.5
	Moderate / Moderato	1.25	1.5	1.75
	Heavy / Forte	1.5	1.75	2.15

D Motor flange available Flange disponibili Erhältliche Motorflansche Brides disponibles Bridas disponibles	
B) Mounting with reduction ring Montaggio con boccia di riduzione Reduzierhülsen Montage avec douille de réduction Montaje con casquillo de reducción	
C) Motor flangeholes position/terminal box position Posizione fori flangia/basetta motore Bohrungsposition am Motorflansch/-socket Position trous bride/barrette à bornes moteur Posición agujeros brida / base motor	
B) Available without reduction bushes Disponibile anche senza boccia Auch ohne Reduzierbuchse verfügbar Disponible aussi sans douille de réduction Disponible tambien sin casquillo	

A	Select required torque (according to service factor)	Seleziona la coppia desiderata (comprensiva del fattore di servizio)	Max. Drehmoment in Bezug zum Betriebsfaktor	Sélectionner le couple souhaité (comprenant le facteur de service)	Seleccionar el par deseado (incluyendo el factor de servicio)
B	Select output speed	Seleziona la velocità in uscita	Ausgewählte Abtriebsdrehzahl	Sélectionner la vitesse de sortie	Seleccionar la velocidad de salida
C	On the same line of selected geared motor, you can find the gear ratio	Sulla riga corrispondente alla motorizzazione prescelta si può rilevare il rapporto di riduzione	Auf der gleichen Linie wie die ausgewählte Motorleistung steht auch die Getriebeuntersetzung	Sur la ligne correspondante à la motorisation pré-choisie on peut relever le rapport de réduction	En la línea correspondiente al motor preseleccionado es posible encontrar la relación de reducción
D	Select motor flange available (if requested)	Scegli la flangia disponibile (se richiesta)	Erhältliche Motorflansche (auf Anfrage)	Choisir la bride disponible (si elle est demandée)	Seleccionar la brida disponible (sobre pedido)



QUICK SELECTION / Selezione veloce

input speed (n_1) = 1400 min⁻¹

Output Speed n_2 [min ⁻¹]	Ratio i	Motor power P_{1M} [kW]	Output torque M_{2M} [Nm]	Service factor f.s.	Nominal power P_{1R} [kW]	Nominal torque M_{2R} [Nm]	Available B5 motor flanges		Available B14 motor flanges			Hollow Shaft 	Ratios code
							-B	-C	-O	-P	-Q		
72	19.42	0.37	46	1.3	0.48	60			C	C		281713	01
51	27.21	0.37	65	0.9	0.34	60			C	C		281313	02
36.4	38.49	0.25	62	1.0	0.24	60			C	C		191713	03
31.7	44.12	0.18	54	1.1	0.21	60			C	C		171713	04
26.7	52.50	0.18	64	0.9	0.18	60			C	C		151713	05
22.6	61.82	0.12	49	1.2	0.15	60			C	C		171313	06
19.0	73.56	0.12	58	1.0	0.13	60			C	C		151313	07
15.9	88.13	0.09	56	1.1	0.11	60			C	C	standard ø17	101713	08
12.0	116.67	0.06	48	1.2	0.08	60			C	C		91713	09
11.3	123.48	0.06	51	1.2	0.08	60			C	C		101313	10
9.0	155.37	0.06	64	0.9	0.06	60			C	C		71713	11
8.6	163.47	0.06	68	0.9	0.06	60			C	C		91313	12
7.6	184.39	0.06	76	0.8	0.05	60			C	C		61713	13
6.4	217.68	0.06*	90	0.7	0.04	60			C	C		71313	14
5.4	258.34	0.06*	107	0.6	0.04	60			C	C		61313	15

The dynamic efficiency is **0.94** for all ratios * Power higher than the maximum one which can be supported by the gearbox. Select according to the torque M_{2R}
Potenza superiore a quella massima sopportabile dal riduttore. Selezionare in base al momento torcente M_{2R}

- Motor Flanges Available** Flange Motore Disponibili
- B) Supplied with Reduction Bushing** Fornito con Bussola di Riduzione
- B) Available on Request without reduction bushing** Disponibile a Richiesta senza Bussola di Riduzione
- C) Motor Flange Holes Position** Posizione Fori Flangia Motore

EN Unit **FS10** is supplied with synthetic oil for lifetime lubrication, no maintenance is necessary. See table 1 for lubrication and recommended quantity. In table 2 please see possible radial loads and axial loads on the gearbox.

I Il riduttore **FS10** viene fornito completo di olio sintetico per la lubrificazione permanente e non necessita di alcuna manutenzione. Vedi tab.1 per oli e quantità consigliati. In tab.2 sono presenti i carichi radiali e assiali applicabili al riduttore.

D Das Getriebe **FS10** ist mit synthetischem Öl gefüllt und ist lebensdauergeschmiert. In Tabelle 1 ist die Schmiermenge und das empfohlene Schmiermittel angegeben. In Tabelle 2 sind die zulässigen Radial- und Axialbelastungen des Getriebes aufgeführt.

F Le réducteur **FS10** est fourni complet avec de l'huile synthétique pour la lubrification permanente et ne nécessite aucun entretien. Voir tableau 1 concernant les huiles et les quantités conseillées. Les charges radiales et axiales applicables au réducteur sont précisées dans le tableau 2.

E El reductor tamaño **FS10** se suministra, lubricado de por vida con aceite sintético y no requieren mantenimiento alguna. Ver tabla 1, para cantidades y aceites recomendados. En la tabla 2, se encuentran las cargas radiales y axiales admitidas por el reductor.

LUBRICATION FS10 Oil Quantity 0.35 Lt.

SHELL Omala S4 WE 320 **ENI** Telium VSF 320

For all details on lubrication and plugs check our website **tab. 1**
Per maggiori dettagli su lubrificazione e tappi olio vedi il nostro sito web

RADIAL LOADS

Input shaft
Albero in entrata

n_1	FA	FR
1400	140	700
900	160	800

*Strong axial loads in the DX direction are not allowed.
Non sono consentiti forti carichi assiali con direzione DX

tab. 2

PFS10... Basic gearbox
Riduttore base

Gearbox weight **3.1 kg**
peso riduttore

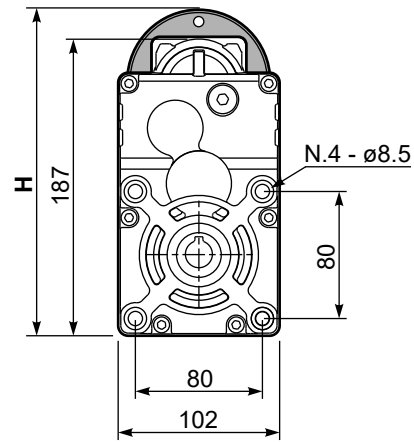
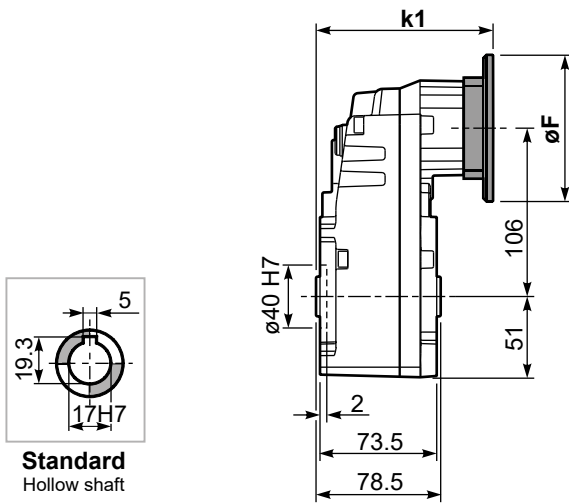

B14 Motor Flanges	H	ϕF	k1	kit code
56 B14	197	80	109.3	KC40.4.049
63 B14	202	90	111.8	K050.4.047
71 B14	209.5	105	109.3	K050.4.045

B5 Motor Flanges	H	ϕF	k1	kit code
63 B5	226	138	111.8	K050.4.041
71 B5	237	160	109.3	K050.4.042

RFS10... Input Shaft
Albero in entrata

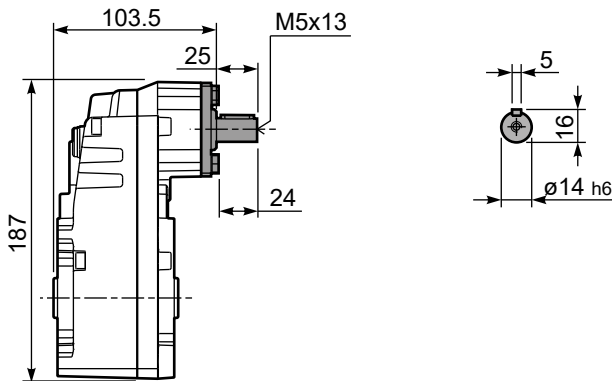



QUICK SELECTION / Selezione veloce

input speed (n_1) = 1400 min⁻¹

Output Speed n_2 [min ⁻¹]	Ratio i	Motor power P_{1M} [kW]	Output torque M_{2M} [Nm]	Service factor f.s.	Nominal power P_{1R} [kW]	Nominal torque M_{2R} [Nm]	Available B5 motor flanges		Available B14 motor flanges			Hollow Shaft standard ø20	Ratios code
							-B	-C	-O	-P	-Q		
24.2	57.95	0.25	93	1.0	0.24	90			C	C		2844	01
13.4	104.80	0.12	83	1.1	0.13	90			C	C		1954	02
11.5	121.47	0.12	96	0.9	0.12	90			C	C		1756	03
9.8	142.59	0.09	90	1.0	0.10	90			C	C		1558	04
8.2	170.20	0.06	70	1.3	0.08	90			C	C		1360	05
6.0	232.32	0.06	96	0.9	0.06	90			C	C		1063	06
4.6	303.20	0.06*	126	0.7	0.05	90			C	C		974	07
3.5	400.37	0.06*	166	0.5	0.04	90			C	C		776	08

The dynamic efficiency is **0.94** for all ratios * Power higher than the maximum one which can be supported by the gearbox. Select according to the torque M_{2R}
Potenza superiore a quella massima sopportabile dal riduttore. Selezionare in base al momento torcente M_{2R}

A Motor Flanges Available
Flange Motore Disponibili

B Supplied with Reduction Bushing
Fornito con Bussola di Riduzione

B Available on Request without reduction bushing
Disponibile a Richiesta senza Bussola di Riduzione

C Motor Flange Holes Position
Posizione Fori Flangia Motore

EN Unit **FS20** is supplied with synthetic oil for lifetime lubrication, no maintenance is necessary. See table 1 for lubrication and recommended quantity. In table 2 please see possible radial loads and axial loads on the gearbox.

I Il riduttore **FS20** viene fornito completo di olio sintetico per la lubrificazione permanente e non necessita di alcuna manutenzione. Vedi tab.1 per oli e quantità consigliati. In tab.2 sono presenti i carichi radiali e assiali applicabili al riduttore.

D Das Getriebe **FS20** ist mit synthetischem Öl gefüllt und ist lebensdauergeschmiert. In Tabelle 1 ist die Schmiermenge und das empfohlene Schmiermittel angegeben. In Tabelle 2 sind die zulässigen Radial- und Axialbelastungen des Getriebes aufgeführt.

F Le réducteur **FS20** est fourni complet avec de l'huile synthétique pour la lubrification permanente et ne nécessite aucun entretien. Voir tableau 1 concernant les huiles et les quantités conseillées. Les charges radiales et axiales applicables au réducteur sont précisées dans le tableau 2.

E El reductor tamaño **FS20** se suministra, lubricado de por vida con aceite sintético y no requieren mantenimiento alguna. Ver tabla 1, para cantidades y aceites recomendados. En la tabla 2, se encuentran las cargas radiales y axiales admitidas por el reductor.

LUBRICATION FS20 Oil Quantity 0.50 Lt.

SHELL Omala S4 WE 320

ENI Telium VSF 320

For all details on lubrication and plugs check our website **tab. 1**
Per maggiori dettagli su lubrificazione e tappi olio vedi il nostro sito web

RADIAL LOADS

Input shaft
Albero in entrata

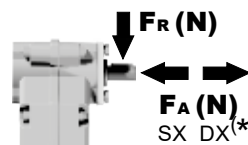

n_1	FA	FR
1400	140	700
900	160	800

*Strong axial loads in the DX direction are not allowed.
Non sono consentiti forti carichi assiali con direzione DX

tab. 2

PFS20... Basic gearbox
Riduttore base

Gearbox weight
peso riduttore **4.3 kg**

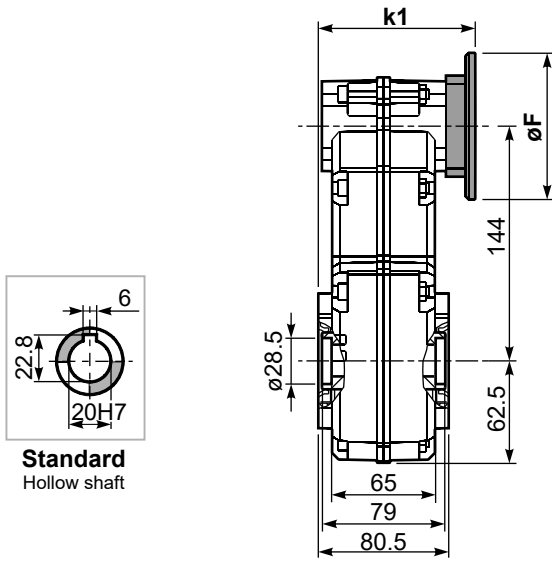

Standard
Hollow shaft

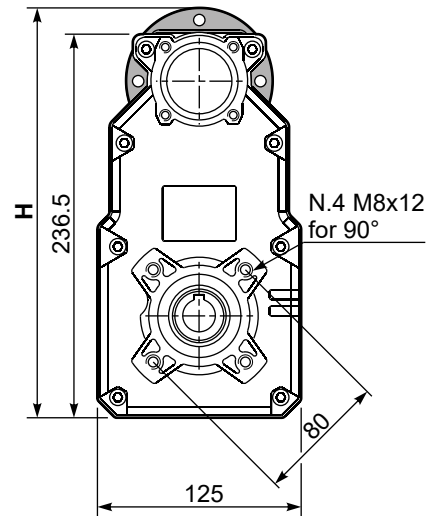

B14 Motor Flanges	H	ϕF	k1	kit code
56 B14	246.5	80	94.3	KC40.4.049
63 B14	251.5	90	96.8	K050.4.047
71 B14	259	105	94.3	K050.4.045

B5 Motor Flanges	H	ϕF	k1	kit code
63 B5	275.5	138	96.8	K050.4.041
71 B5	286.5	160	94.3	K050.4.042

RFS20... Input Shaft
Albero in entrata

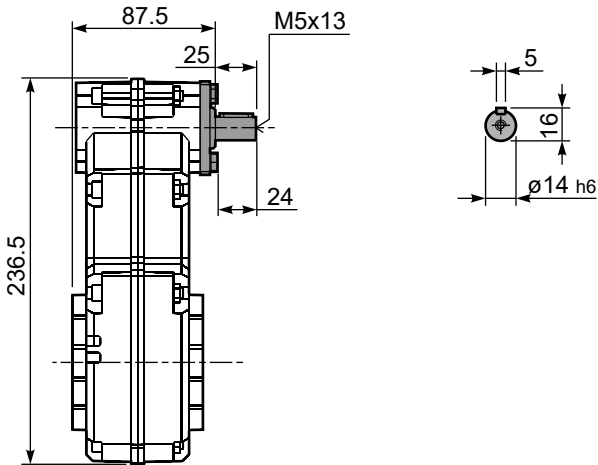



QUICK SELECTION / Selezione veloce input speed (n_1) = 1400 min⁻¹

Output Speed n_2 [min ⁻¹]	Ratio i	Motor power P_{1M} [kW]	Output torque M_{2M} [Nm]	Service factor f.s.	Nominal power P_{1R} [kW]	Nominal torque M_{2R} [Nm]	Available B5 motor flanges					Available B14 motor flanges				Output Shaft 	Ratios code
							-B	-C	-D	-E	-F	-Q	-R	-T	-U		
							63	71	80	90	100	112	71	80	90		
231	6.06	2.2	86	0.9	2.02	80	B					C	C			2821	01
150	9.31	1.5	91	1.0	1.48	90	B					C	C			2813	02
128	10.96	1.5	107	1.0	1.53	110	B					C	C			1921	03
110	12.71	1.5	124	1.0	1.50	125	B					C	C			1721	04
94	14.91	1.5	146	1.0	1.45	142	B					C	C			1521	05
83	16.83	1.5	165	0.9	1.36	150	B					C	C			1913	06
79	17.80	1.1	127	1.2	1.29	150	B					C	C			1321	07
72	19.51	1.1	140	1.1	1.17	150	B					C	C			1713	08
61	22.90	1.1	164	0.9	1.00	150	B					C	C			1513	09
58	24.30	1.1	174	0.9	0.94	150	B					C	C			1021	10
54	26.15	0.75	128	1.2	0.88	150	B					C	C			1910	11
51	27.34	0.75	134	1.1	0.84	150	B					C	C			1313	12
46.2	30.31	0.75	149	1.0	0.76	150	B					C	C			1710	13
44.1	31.71	0.75	156	1.0	0.72	150	B					C	C			921	14
39.4	35.57	0.75	175	0.9	0.64	150	B					C	C			1510	15
37.5	37.32	0.55	135	1.1	0.61	150	B					C	C			1013	16
33.0	42.46	0.55	154	1.0	0.54	150	B					C	C			1310	17
28.7	48.70	0.55	176	0.9	0.47	150	B					C	C			913	18
24.2	57.96	0.37	140	1.1	0.40	150	B					C	C			1010	19
21.8	64.31	0.37	156	1.0	0.36	150	B					C	C			713	20
18.5	75.64	0.25	124	1.2	0.30	150	B					C	C			910	21
14.0	99.89	0.25	163	0.9	0.23	150	B					C	C			710	22

The dynamic efficiency is **0.96** for all ratios

Motor Flanges Available Flange Motore Disponibili
 B) Supplied with Reduction Bushing Fornito con Bussola di Riduzione
 B) Available on Request without reduction bushing Disponibile a Richiesta senza Bussola di Riduzione
 C) Motor Flange Holes Position Posizione Fori Flangia Motore

EN Unit **FA32** is supplied with synthetic oil for lifetime lubrication, no maintenance is necessary. See table 1 for lubrication and recommended quantity. In table 2 please see possible radial loads and axial loads on the gearbox.

I Il riduttore **FA32** viene fornito completo di olio sintetico per la lubrificazione permanente e non necessita di alcuna manutenzione. Vedi tab.1 per oli e quantità consigliati. In tab.2 sono presenti i carichi radiali e assiali applicabili al riduttore.

D Das Getriebe **FA32** ist mit synthetischem Öl gefüllt und ist lebensdauergeschmiert. In Tabelle 1 ist die Schmiermenge und das empfohlene Schmiermittel angegeben. In Tabelle 2 sind die zulässigen Radial- und Axialbelastungen des Getriebes aufgeführt.

F Le réducteur **FA32** est fourni complet avec de l'huile synthétique pour la lubrification permanente et ne nécessite aucun entretien. Voir tableau 1 concernant les huiles et les quantités conseillées. Les charges radiales et axiales applicables au réducteur sont précisées dans le tableau 2.

E El reductor tamaño **FA32** se suministra, lubricado de por vida con aceite sintético y no requieren mantenimiento alguna. Ver tabla 1, para cantidades y aceites recomendados. En la tabla 2, se encuentran las cargas radiales y axiales admitidas por el reductor.

Standard supplied	For these mounting position specify in the order or add oil Per queste posizioni specificare in fase d'ordine o aggiungere olio				
H1	H4	H3	H2	H5	H6
0.65 LT	0.50 LT	0.50 LT	0.60 LT	0.80 LT	0.65 LT
SHELL Omala S4 WE 320			ENI Telium VSF 320		

For all details on lubrication and plugs check our website tab. 1
Per maggiori dettagli su lubrificazione e tappi olio vedi il nostro sito web

RADIAL AND AXIAL LOADS

Output shaft
Albero di uscita

$F_R(N)$
 $F_A(N)$

$F_{eq} = FR \cdot \frac{106}{X+80}$

$F_{eq}(N)$

n_2 [min ⁻¹]	FA	FR	n_2 [min ⁻¹]	FA	FR	n_2 [min ⁻¹]	FA	FR
300	250	1250	140	360	1800	70	470	2350
250	270	1350	120	380	1900	40	550	2750
200	320	1600	85	440	2200	15	560	2800

On request reinforced bearings to increase loads.
A richiesta cuscinetti rinforzati per aumentare i carichi.

Input shaft
Albero in entrata

$F_R(N)$
 $F_A(N)$

n_1	FA	FR
1400	240	1200
900	280	1400
500	340	1700

tab. 2

PFA32C... Basic gearbox
Riduttore base

Gearbox weight **7.0 kg**
peso riduttore

M. flanges	Kit code	øF	A
63B5	K063.4.041	140	176.5
71B5	K063.4.042	160	174.5
80/90B5	K063.4.043	200	176.5
100/112B5	KC40.4.043	250	191.5
71B14	K063.4.047	105	174.5
80B14	K063.4.046	120	176.5
90B14	K063.4.041	140	176.5
100/112B14	KC40.4.041	160	191.5

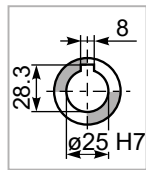

Standard
Hollow shaft

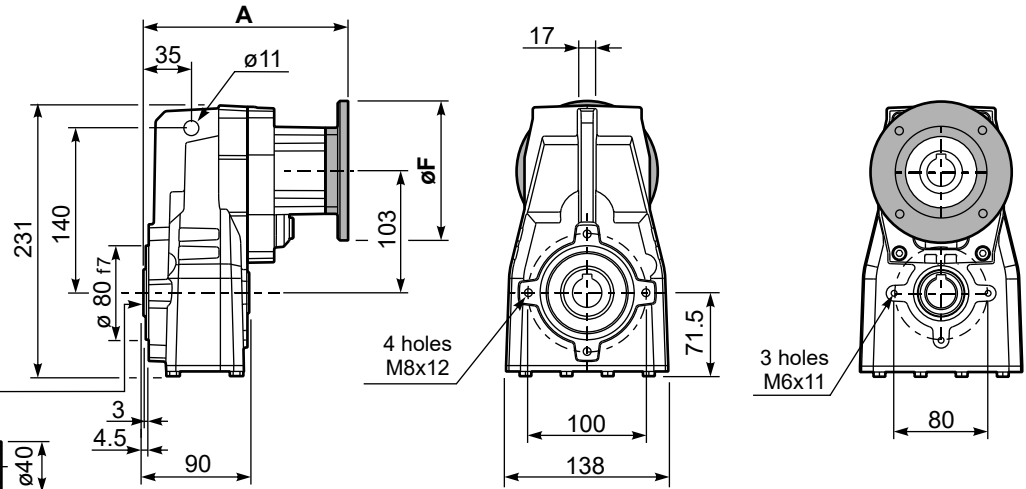
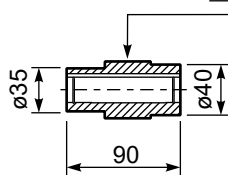

PFA32...-F... Output flange
Flangia uscita

Motor Flange	k1
63B5	208
71B5	206
80/90B5	208
100/112B5	223
71B14	206
80B14	208
90B14	208
100/112B14	223

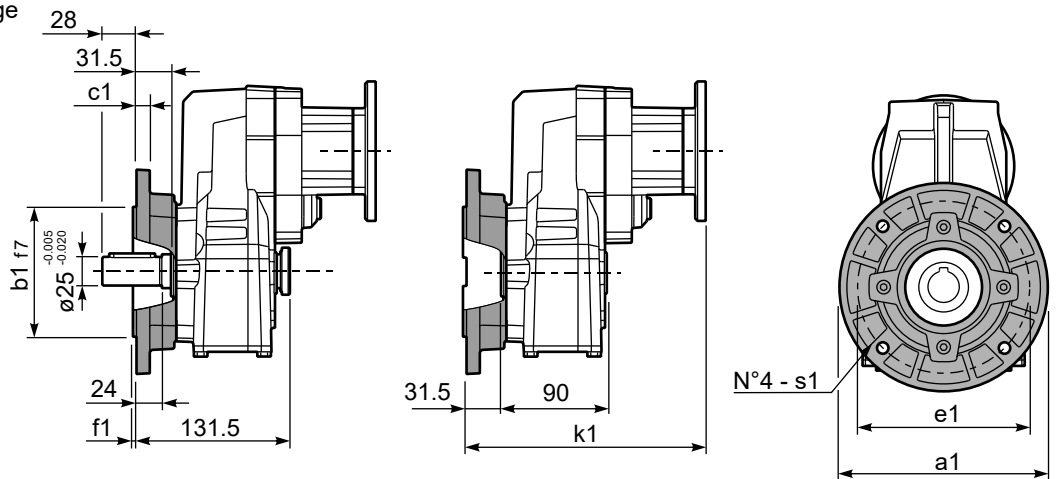

Available output flanges
Flange di uscita

a1 ø	b1	c1	e1	f1	s1	Kit code
160	110	10	130	3	9	KX4A.9.010
200	130	11	165	3.5	11	KX4A.9.011
-	-	-	-	-	-	-

RFA32C... Input Shaft
Albero in entrata

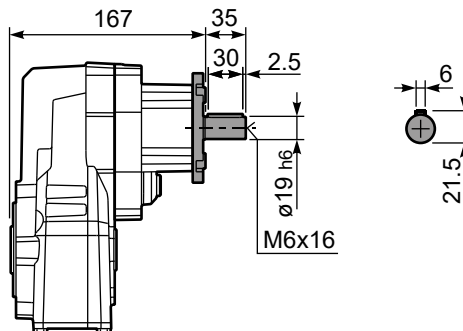

PFA32 A... Single output shaft
Albero uscita semplice

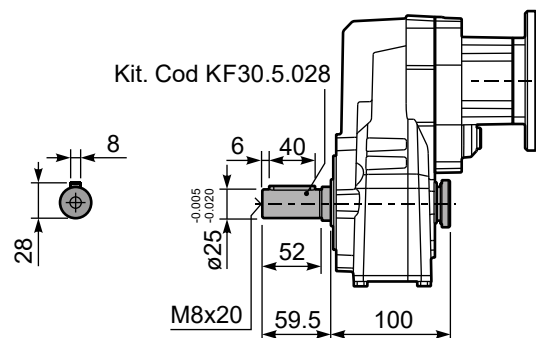



QUICK SELECTION / Selezione veloce							input speed (n ₁) = 1400 min ⁻¹						
Output Speed n ₂ [min ⁻¹]	Ratio i	Motor power P _{1M} [kW]	Output torque M _{2M} [Nm]	Service factor f.s.	Nominal power P _{1R} [kW]	Nominal torque M _{2R} [Nm]	Available B5 motor flanges		Available B14 motor flanges			Output Shaft Ø	Ratios code
							-B	-C	-O	-P	-Q		
13.6	102.57	0.25	164	0.9	0.23	150			C	C		131710	01
12.6	110.77	0.18	136	1.1	0.21	150			C	C		91321	02
11.8	118.89	0.18	145	1.0	0.20	150			C	C		151310	03
10.9	128.49	0.18	157	1.0	0.18	150			C	C		101313	04
9.7	143.72	0.18	176	0.9	0.16	150			C	C		131310	05
8.7	161.67	0.12	128	1.2	0.14	150			C	C		71713	06
8.2	170.10	0.12	134	1.1	0.14	150			C	C		91313	07
7.4	188.57	0.12	149	1.0	0.12	150			C	C		91710	08
7.0	199.57	0.12	158	1.0	0.12	150			C	C		101310	09
6.2	226.51	0.09	143	1.1	0.10	150			C	C		71313	10
5.6	251.11	0.09	158	0.9	0.09	150			C	C		71710	11
5.3	264.21	0.09	167	0.9	0.09	150			C	C		91310	12
4.7	298.01	0.06	123	1.2	0.08	150			C	C		61710	13
4.0	351.82	0.06	146	1.0	0.07	150			C	C		71310	14
3.4	417.54	0.06	173	0.9	0.06	150			C	C		61310	15

The dynamic efficiency is **0.94** for all ratios

- Motor Flanges Available**
Flange Motore Disponibili
- B) Supplied with Reduction Bushing**
Fornito con Bussola di Riduzione
- B) Available on Request without reduction bushing**
Disponibile a Richiesta senza Bussola di Riduzione
- C) Motor Flange Holes Position**
Posizione Fori Flangia Motore

EN Unit **FA33** is supplied with synthetic oil for lifetime lubrication, no maintenance is necessary. See table 1 for lubrication and recommended quantity. In table 2 please see possible radial loads and axial loads on the gearbox.

I Il riduttore **FA33** viene fornito completo di olio sintetico per la lubrificazione permanente e non necessita di alcuna manutenzione. Vedi tab.1 per oli e quantità consigliati. In tab.2 sono presenti i carichi radiali e assiali applicabili al riduttore.

D Das Getriebe **FA33** ist mit synthetischem Öl gefüllt und ist lebensdauergeschmiert. In Tabelle 1 ist die Schmiermenge und das empfohlene Schmiermittel angegeben. In Tabelle 2 sind die zulässigen Radial- und Axialbelastungen des Getriebes aufgeführt.

F Le réducteur **FA33** est fourni complet avec de l'huile synthétique pour la lubrification permanente et ne nécessite aucun entretien. Voir tableau 1 concernant les huiles et les quantités conseillées. Les charges radiales et axiales applicables au réducteur sont précisées dans le tableau 2.

E El reductor tamaño **FA33** se suministra, lubricado de por vida con aceite sintético y no requieren mantenimiento alguna. Ver tabla 1, para cantidades y aceites recomendados. En la tabla 2, se encuentran las cargas radiales y axiales admitidas por el reductor.

Standard supplied	For these mounting position specify in the order or add oil Per queste posizioni specificare in fase d'ordine o aggiungere olio				
H1	H4	H3	H2	H5	H6
0.90 LT	0.55 LT	0.55 LT	0.65 LT	0.95 LT	0.70 LT
SHELL Omala S4 WE 320			ENI Telium VSF 320		

For all details on lubrication and plugs check our website [tab. 1](#)
Per maggiori dettagli su lubrificazione e tappi olio vedi il nostro sito web

RADIAL AND AXIAL LOADS								
Output shaft Albero di uscita		$F_{eq} = FR \cdot \frac{106}{X+80}$						
n ₂ [min ⁻¹]	FA	FR	n ₂ [min ⁻¹]	FA	FR	n ₂ [min ⁻¹]	FA	FR
300	250	1250	140	360	1800	70	470	2350
250	270	1350	120	380	1900	40	550	2750
200	320	1600	85	440	2200	15	560	2800
On request reinforced bearings to increase loads. A richiesta cuscinetti rinforzati per aumentare i carichi.								
Input shaft Albero in entrata								
n ₁	FA	FR						
1400	140	700						
900	160	800						
500	190	950						

tab. 2

PFA33C... Basic gearbox
Riduttore base

Gearbox weight **7.0 kg**
peso riduttore

M. flanges	Kit code	øF	A
63B5	K050.4.041	138	182
71B5	K050.4.042	160	179.5
56B14	KC40.4.049	80	179.5
63B14	K050.4.047	90	182
71B14	K050.4.045	105	179.5

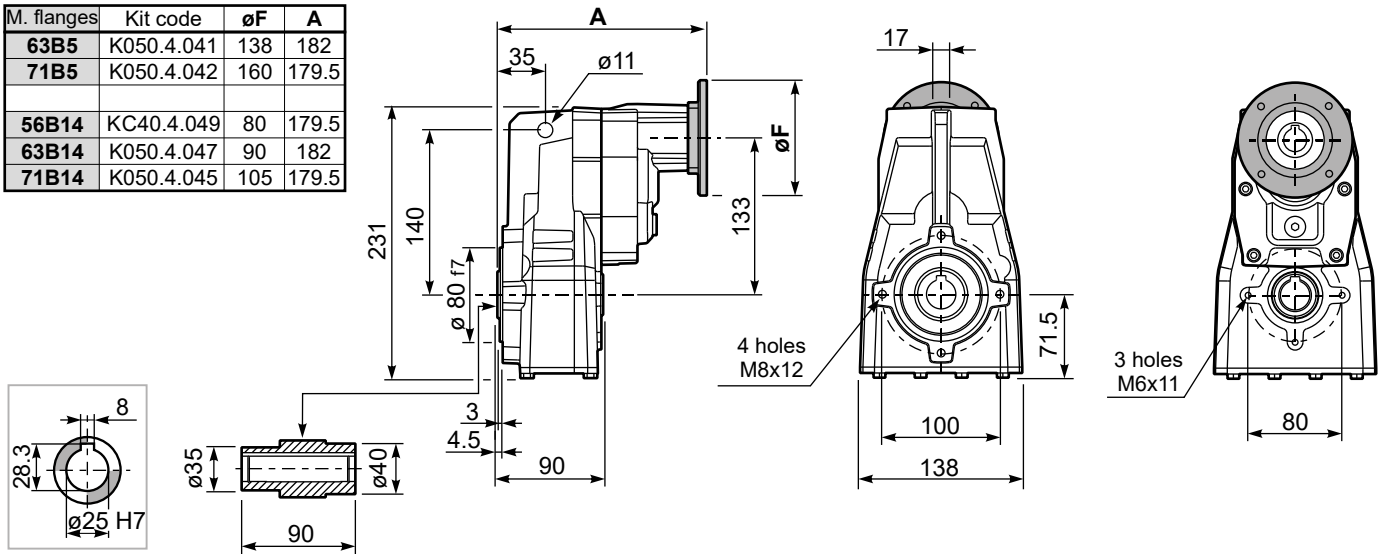

Standard
Hollow shaft

PFA33...-**F**... Output flange
Flangia uscita

Motor Flange	k1
63B5	213.5
71B5	211
56B14	211
63B14	213.5
71B14	211

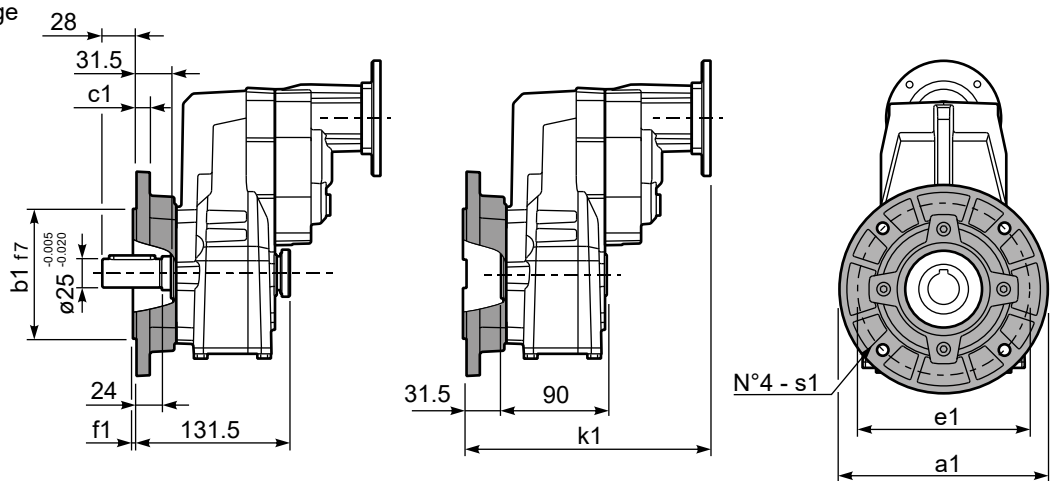

Available output flanges
Flange di uscita

a1 ø	b1	c1	e1	f1	s1	Kit code
160	110	10	130	3	9	KX4A.9.010
200	130	11	165	3.5	11	KX4A.9.011
-	-	-	-	-	-	-

RFA33C... Input Shaft
Albero in entrata

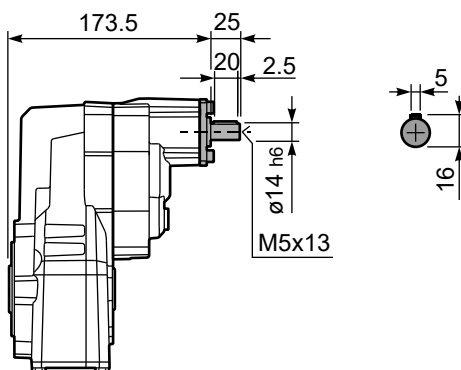

PFA33 **A**... Single output shaft
Albero uscita semplice

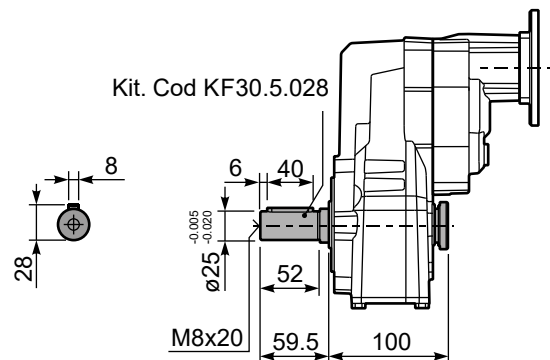

Kit. Cod KF30.5.028



QUICK SELECTION / Selezione veloce input speed (n_1) = 1400 min⁻¹

Output Speed n_2 [min ⁻¹]	Ratio i	Motor power P_{1M} [kW]	Output torque M_{2M} [Nm]	Service factor f.s.	Nominal power P_{1R} [kW]	Nominal torque M_{2R} [Nm]	Available B5 motor flanges			Available B14 motor flanges			Output Shaft		
							-D	-E	-F	-R	-T	-U			Ratios code
							80	90	100 112	80	90	100 112		\emptyset	
481	2.91	4	76	1.8	7.2	140	B	B		B	B		3499	standard	01
373	3.75	4	98	1.6	6.4	160	B	B		B	B		28105	ø30	02
263	5.33	4	140	1.2	4.8	170	B	B		B	B		21112		03
219	6.39	4	167	1.0	4.0	170	B	B		B	B		18115	ø25	04
178	7.85	4	205	1.1	4.3	225	B	B		B	B		13102	ø35	05

On request

The dynamic efficiency is **0.98** for all ratios

Motor Flanges Available Flange Motore Disponibili
 B) Supplied with Reduction Bushing Fornito con Bussola di Riduzione
 B) Available on Request without reduction bushing Disponibile a Richiesta senza Bussola di Riduzione
 C) Motor Flange Holes Position Posizione Fori Flangia Motore

EN Unit **FA41** is supplied with synthetic oil for lifetime lubrication, no maintenance is necessary. See table 1 for lubrication and recommended quantity. In table 2 please see possible radial loads and axial loads on the gearbox.

I Il riduttore **FA41** viene fornito completo di olio sintetico per la lubrificazione permanente e non necessita di alcuna manutenzione. Vedi tab.1 per oli e quantità consigliati. In tab.2 sono presenti i carichi radiali e assiali applicabili al riduttore.

D Das Getriebe **FA41** ist mit synthetischem Öl gefüllt und ist lebensdauergeschmiert. In Tabelle 1 ist die Schmiermenge und das empfohlene Schmiermittel angegeben. In Tabelle 2 sind die zulässigen Radial- und Axialbelastungen des Getriebes aufgeführt.

F Le réducteur **FA41** est fourni complet avec de l'huile synthétique pour la lubrification permanente et ne nécessite aucun entretien. Voir tableau 1 concernant les huiles et les quantités conseillées. Les charges radiales et axiales applicables au réducteur sont précisées dans le tableau 2.

E El reductor tamaño **FA41** se suministra, lubricado de por vida con aceite sintético y no requieren mantenimiento alguna. Ver tabla 1, para cantidades y aceites recomendados. En la tabla 2, se encuentran las cargas radiales y axiales admitidas por el reductor.

Standard supplied	For these mounting position specify in the order or add oil Per queste posizioni specificare in fase d'ordine o aggiungere olio				
1.10 LT	0.65 LT	0.65 LT	0.65 LT	1.15 LT	0.80 LT
SHELL Omala S4 WE 320			ENI Telium VSF 320		

For all details on lubrication and plugs check our website tab. 1
Per maggiori dettagli su lubrificazione e tappi olio vedi il nostro sito web

RADIAL AND AXIAL LOADS

Output shaft
Albero di uscita

F_R (N)
 F_A (N)

$F_{eq} = F_R \cdot \frac{127.5}{X+97.5}$

n_2 [min ⁻¹]	FA	FR	n_2 [min ⁻¹]	FA	FR	n_2 [min ⁻¹]	FA	FR
300	300	1500	140	390	1950	70	490	2450
250	320	1600	120	410	2050	40	590	2950
200	350	1750	85	460	2300	15	800	4000

On request reinforced bearings to increase loads.
A richiesta cuscinetti rinforzati per aumentare i carichi.

tab. 2

PFA41C... Basic gearbox
Riduttore base

Gearbox weight
peso riduttore **12.1 kg**

M. flanges	Kit code	øF	A
80/90B5	K023.4.042	200	179.5
100/112B5	K023.4.043	250	188.5
80B14	K085.4.046	120	179.5
90B14	K085.4.045	140	179.5
100/112B14	K085.4.047	160	

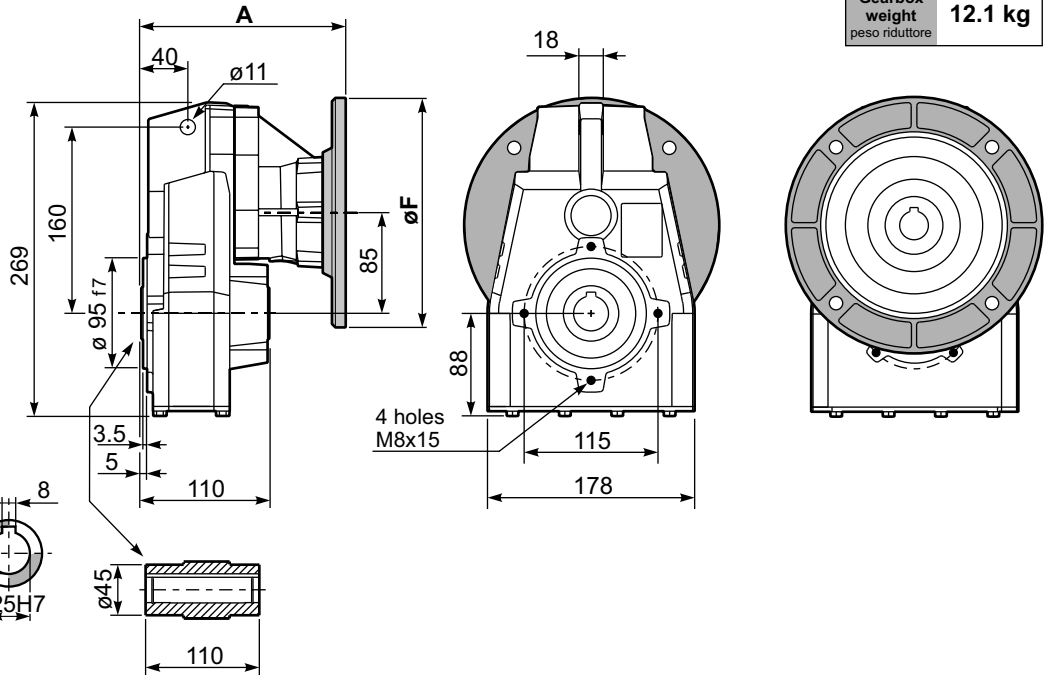

Standard
Hollow shaft

On request
A richiesta

PFA41...-F... Output flange
Flangia uscita

M. flanges	k1
80/90B5	215.5
100/112B5	221.5
80B14	213.5
90B14	213.5
100/112B14	224.5

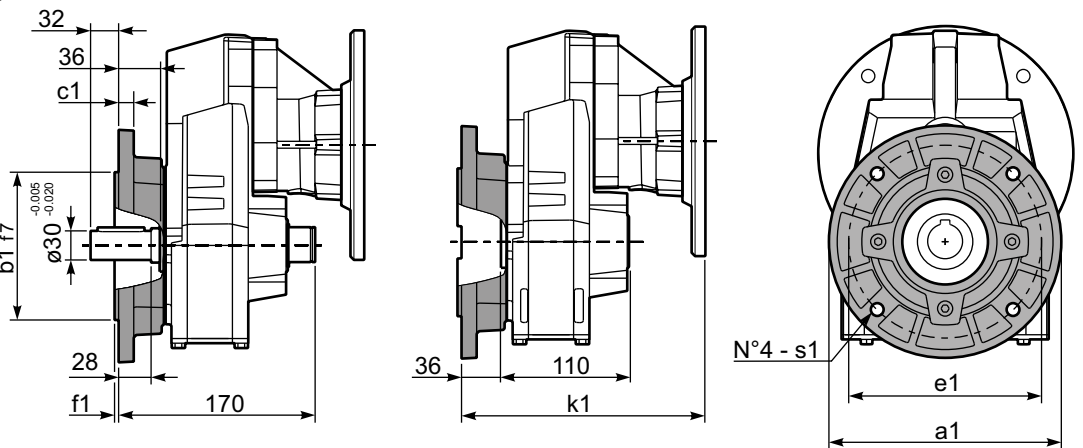

Available output flanges
Flange di uscita

a1 ø	b1	c1	e1	f1	s1	Kit code
160	110	10	130	3	9	KX5A.9.010
200	130	13	165	3.5	11	KX5A.9.011
250	180	14	215	4	14	KX5A.9.012

PFA41 A... Single output shaft
Albero uscita semplice

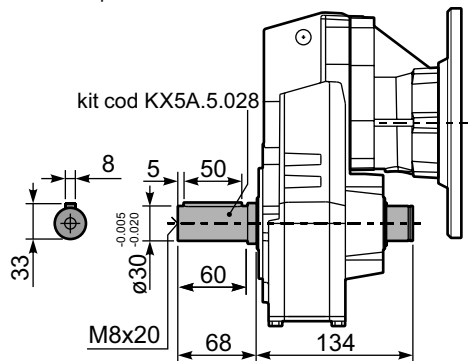



QUICK SELECTION / Selezione veloce input speed (n₁) = 1400 min⁻¹

Output Speed n ₂ [min ⁻¹]	Ratio i	Motor power P _{1M} [kW]	Output torque M _{2M} [Nm]	Service factor f.s.	Nominal power P _{1R} [kW]	Nominal torque M _{2R} [Nm]	Available B5 motor flanges					Available B14 motor flanges				Output Shaft 	Ratios code
							-B	-C	-D	-E	-F	-Q	-R	-T	-U		
							63	71	80	90	100	112	71	80	90		
167	8.38	4	215	1.0	4.1	225	B					C	C			2821	01
139	10.04	3	194	1.2	3.7	240	B					C	C			2818	02
114	12.33	3	238	1.1	3.2	260	B					C	C			2813	03
92	15.16	2.2	215	1.2	2.6	260	B					C	C			1921	04
80	17.57	2.2	250	1.1	2.3	270	B					C	C			1721	05
77	18.16	2.2	258	1.1	2.4	290	B					C	C			1918	06
67	21.05	2.2	299	1.1	2.3	320	B					C	C			1718	07
63	22.30	2.2	317	1.0	2.2	320	B					C	C			1913	08
57	24.70	1.5	242	1.3	2.0	320	B					C	C			1518	09
54	25.85	1.5	253	1.3	1.9	320	B					C	C			1713	10
47.5	29.49	1.5	289	1.1	1.7	320	B					C	C			1318	11
46.1	30.34	1.5	297	1.1	1.6	320	B					C	C			1513	12
41.7	33.60	1.1	240	1.0	1.1	250	B					C	C			1021	13
38.7	36.21	1.1	259	1.2	1.3	320	B					C	C			1313	14
34.8	40.25	1.1	288	1.0	1.1	300	B					C	C			1018	15
28.3	49.43	1.1	354	0.9	0.99	320	B					C	C			1013	16
26.7	52.53	0.75	258	1.0	0.76	260	B					C	C			918	17
21.7	64.51	0.75	317	1.0	0.75	315	B					C	C			913	18
20.2	69.37	0.37	168	1.1	0.42	190	B					C	C			718	19
16.4	85.19	0.37	206	1.1	0.41	230	B					C	C			713	20

The dynamic efficiency is **0.96** for all ratios

Motor Flanges Available Flange Motore Disponibili
 B) Supplied with Reduction Bushing Fornito con Bussola di Riduzione
 B) Available on Request without reduction bushing Disponibile a Richiesta senza Bussola di Riduzione
 C) Motor Flange Holes Position Posizione Fori Flangia Motore

EN Unit **FA42** is supplied with synthetic oil for lifetime lubrication, no maintenance is necessary. See table 1 for lubrication and recommended quantity. In table 2 please see possible radial loads and axial loads on the gearbox.

I Il riduttore **FA42** viene fornito completo di olio sintetico per la lubrificazione permanente e non necessita di alcuna manutenzione. Vedi tab.1 per oli e quantità consigliati. In tab.2 sono presenti i carichi radiali e assiali applicabili al riduttore.

D Das Getriebe **FA42** ist mit synthetischem Öl gefüllt und ist lebensdauergeschmiert. In Tabelle 1 ist die Schmiermenge und das empfohlene Schmiermittel angegeben. In Tabelle 2 sind die zulässigen Radial - und Axialbelastungen des Getriebes aufgeführt.

F Le réducteur **FA42** est fourni complet avec de l'huile synthétique pour la lubrification permanente et ne nécessite aucun entretien. Voir tableau 1 concernant les huiles et les quantités conseillées. Les charges radiales et axiales applicables au réducteur sont précisées dans le tableau 2.

E El reductor tamaño **FA42** se suministra, lubricado de por vida con aceite sintético y no requieren mantenimiento alguna. Ver tabla 1, para cantidades y aceites recomendados. En la tabla 2, se encuentran las cargas radiales y axiales admitidas por el reductor.

Standard supplied	For these mounting position specify in the order or add oil Per queste posizioni specificare in fase d'ordine o aggiungere olio				
H1	H4	H3	H2	H5	H6
1.15 LT	0.70 LT	0.70 LT	0.70 LT	1.20 LT	0.80 LT
SHELL Omala S4 WE 320			ENI Telium VSF 320		

For all details on lubrication and plugs check our website tab. 1
Per maggiori dettagli su lubrificazione e tappi olio vedi il nostro sito web

RADIAL AND AXIAL LOADS

Output shaft
Albero di uscita

$Feq = FR \cdot \frac{127.5}{X+97.5}$

n ₂ [min ⁻¹]	FA	FR	n ₂ [min ⁻¹]	FA	FR	n ₂ [min ⁻¹]	FA	FR
300	300	1500	140	390	1950	70	490	2450
250	320	1600	120	410	2050	40	590	2950
200	350	1750	85	460	2300	15	800	4000

On request reinforced bearings to increase loads.
A richiesta cuscinetti rinforzati per aumentare i carichi.

Input shaft
Albero in entrata

n ₁	FA	FR
1400	240	1200
900	280	1400
500	340	1700

tab. 2

PFA42C... Basic gearbox
Riduttore base

Gearbox weight
peso riduttore **9.0 kg**

M. flanges	Kit code	øF	A
63B5	K063.4.041	140	169.5
71B5	K063.4.042	160	167.5
80/90B5	K063.4.043	200	169.5
100/112B5	KC40.4.043	250	184.5
71B14	K063.4.047	105	167.5
80B14	K063.4.046	120	169.5
90B14	K063.4.041	140	169.5
100/112B14	KC40.4.041	160	184.5

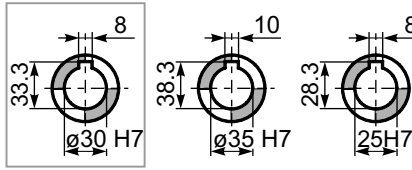
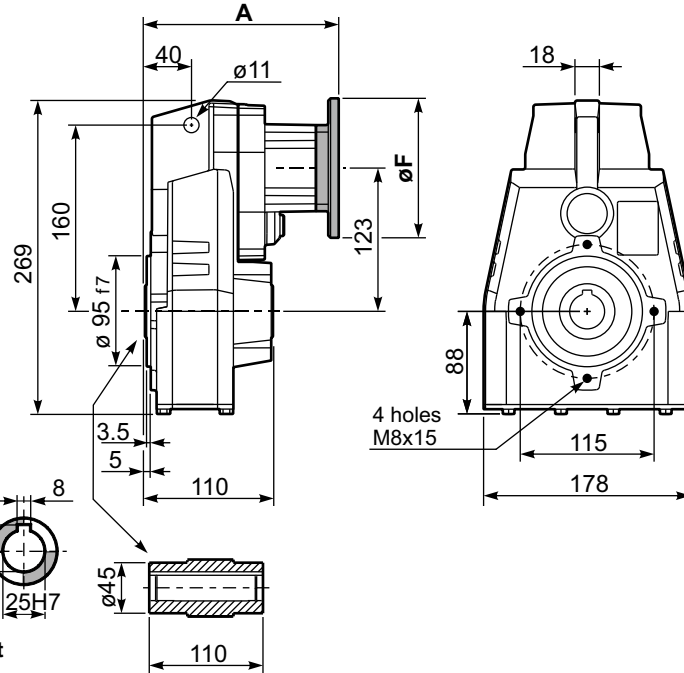

Standard
Hollow shaft

On request
A richiesta

PFA42...-F... Output flange
Flangia uscita

Motor Flange	k1
63B5	205.5
71B5	203.5
80/90B5	205.5
100/112B5	220.5
71B14	203.5
80B14	205.5
90B14	205.5
100/112B14	220.5

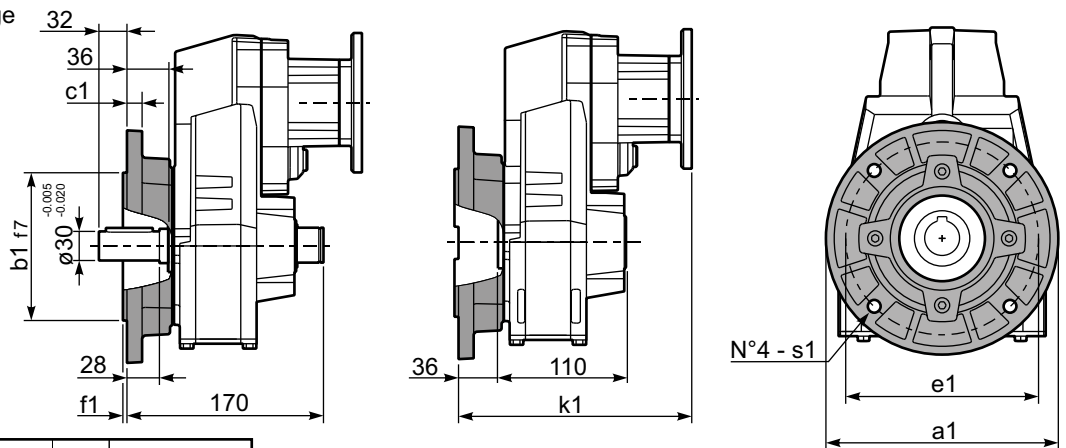

Available output flanges
Flange di uscita

a1 ø	b1	c1	e1	f1	s1	Kit code
160	110	10	130	3	9	KX5A.9.010
200	130	13	165	3.5	11	KX5A.9.011
250	180	14	215	4	14	KX5A.9.012

RFA42C... Input Shaft
Albero in entrata

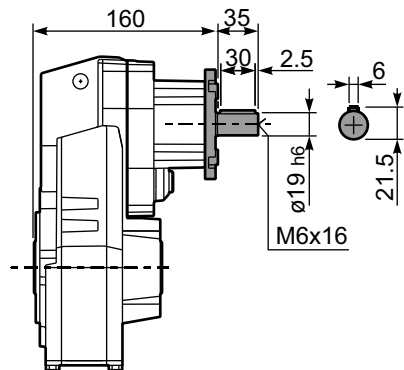

PFA42 A... Single output shaft
Albero uscita semplice

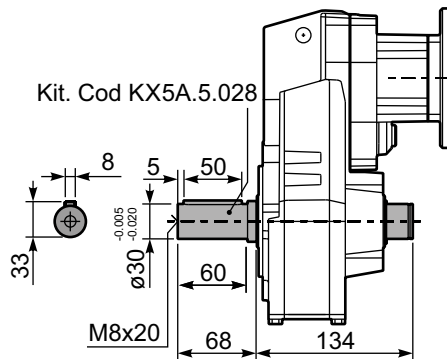

PFA42D... Shrink disk
Calettatore

Kit. Cod KF40.0.210LM

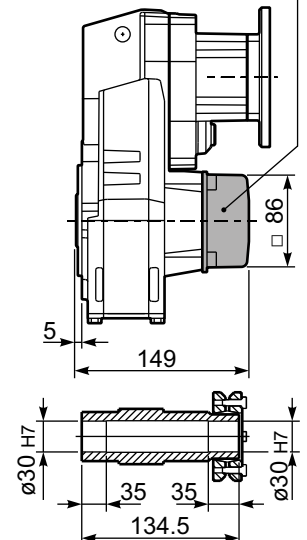



QUICK SELECTION / Selezione veloce							input speed (n ₁) = 1400 min ⁻¹						
Output Speed n ₂ [min ⁻¹]	Ratio i	Motor power P _{1M} [kW]	Output torque M _{2M} [Nm]	Service factor f.s.	Nominal power P _{1R} [kW]	Nominal torque M _{2R} [Nm]	Available B5 motor flanges		Available B14 motor flanges			Output Shaft Ø	Ratios code
							-B	-C	-O	-P	-Q		
18.8	74.33	0.37	176	1.8	0.67	320			C	C		191313	01
17.0	82.56	0.37	196	1.6	0.60	320			C	C		151318	02
16.0	87.48	0.37	207	1.5	0.57	320			C	C		131713	03
13.8	101.40	0.37	240	1.3	0.49	320			C	C		151313	04
11.4	122.57	0.37	291	1.1	0.41	320			C	C		131313	05
10.1	138.59	0.37	329	1.0	0.36	320			C	C		101318	06
8.7	160.82	0.25	257	1.2	0.31	320			C	C		91713	07
8.2	170.20	0.25	272	1.2	0.29	320			C	C		101313	08
7.6	183.48	0.25	294	1.1	0.27	320			C	C		91318	09
6.5	214.15	0.18	262	1.2	0.23	320			C	C		71713	10
6.2	225.33	0.18	276	1.2	0.22	320			C	C		91313	11
5.7	244.32	0.18	299	1.1	0.20	320			C	C		71318	12
5.5	254.15	0.18	311	1.0	0.20	320			C	C		61713	13
4.8	289.96	0.18	355	0.9	0.17	320			C	C		61318	14
4.7	300.05	0.18	367	0.9	0.17	320			C	C		71313	15
3.9	356.09	0.12	282	1.1	0.14	320			C	C		61313	16

The dynamic efficiency is **0.94** for all ratios

Motor Flanges Available Flange Motore Disponibili
 B) Supplied with Reduction Bushing Fornito con Bussola di Riduzione
 B) Available on Request without reduction bushing Disponibile a Richiesta senza Bussola di Riduzione
 C) Motor Flange Holes Position Posizione Fori Flangia Motore

EN Unit **FA43** is supplied with synthetic oil for lifetime lubrication, no maintenance is necessary. See table 1 for lubrication and recommended quantity. In table 2 please see possible radial loads and axial loads on the gearbox.

I Il riduttore **FA43** viene fornito completo di olio sintetico per la lubrificazione permanente e non necessita di alcuna manutenzione. Vedi tab.1 per oli e quantità consigliati. In tab.2 sono presenti i carichi radiali e assiali applicabili al riduttore.

D Das Getriebe **FA43** ist mit synthetischem Öl gefüllt und ist lebensdauergeschmiert. In Tabelle 1 ist die Schmiermenge und das empfohlene Schmiermittel angegeben. In Tabelle 2 sind die zulässigen Radial- und Axialbelastungen des Getriebes aufgeführt.

F Le réducteur **FA43** est fourni complet avec de l'huile synthétique pour la lubrification permanente et ne nécessite aucun entretien. Voir tableau 1 concernant les huiles et les quantités conseillées. Les charges radiales et axiales applicables au réducteur sont précisées dans le tableau 2.

E El reductor tamaño **FA43** se suministra, lubricado de por vida con aceite sintético y no requieren mantenimiento alguna. Ver tabla 1, para cantidades y aceites recomendados. En la tabla 2, se encuentran las cargas radiales y axiales admitidas por el reductor.

Standard supplied	For these mounting position specify in the order or add oil Per queste posizioni specificare in fase d'ordine o aggiungere olio				
H1	H4	H3	H2	H5	H6
1.30 LT	0.70 LT	0.70 LT	0.70 LT	1.35 LT	0.90 LT
SHELL Omala S4 WE 320			ENI Telium VSF 320		

For all details on lubrication and plugs check our website **tab. 1**
Per maggiori dettagli su lubrificazione e tappi olio vedi il nostro sito web

RADIAL AND AXIAL LOADS

Output shaft
Albero di uscita

Input shaft
Albero in entrata

n ₂ [min ⁻¹]	FA	FR	n ₂ [min ⁻¹]	FA	FR	n ₂ [min ⁻¹]	FA	FR
300	300	1500	140	390	1950	70	490	2450
250	320	1600	120	410	2050	40	590	2950
200	350	1750	85	460	2300	15	800	4000

On request reinforced bearings to increase loads.
A richiesta cuscinetti rinforzati per aumentare i carichi.

tab. 2

PFA43C... Basic gearbox
Riduttore base

Gearbox weight
peso riduttore **8.9 kg**

M. flanges	Kit code	øF	A
63B5	K050.4.041	138	175
71B5	K050.4.042	160	172.5
56B14	KC40.4.049	80	172.5
63B14	K050.4.047	90	175
71B14	K050.4.045	105	172.5

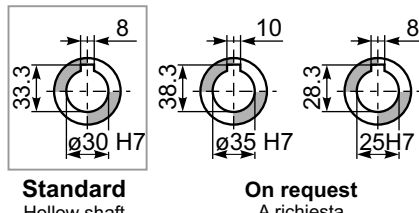
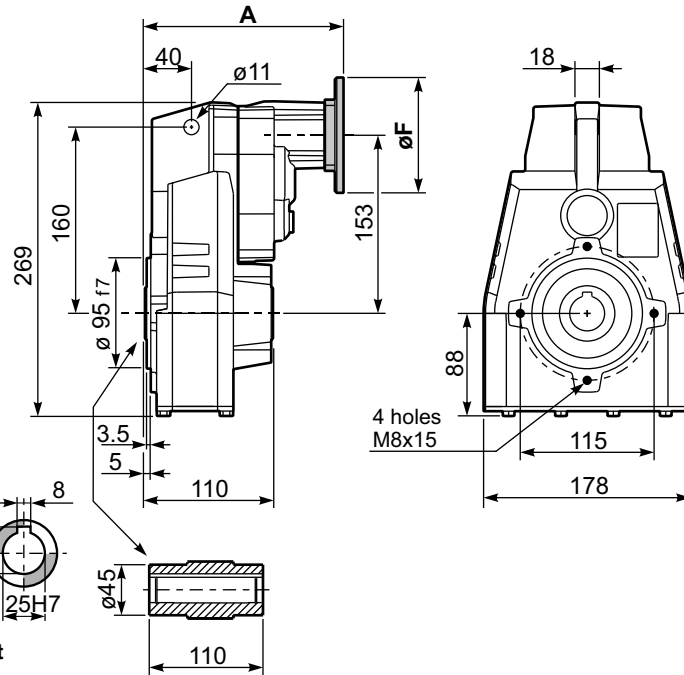

Standard
Hollow shaft

On request
A richiesta

PFA43...-F... Output flange
Flangia uscita

Motor Flange	k1
63B5	211
71B5	208.5
56B14	208.5
63B14	211
71B14	208.5

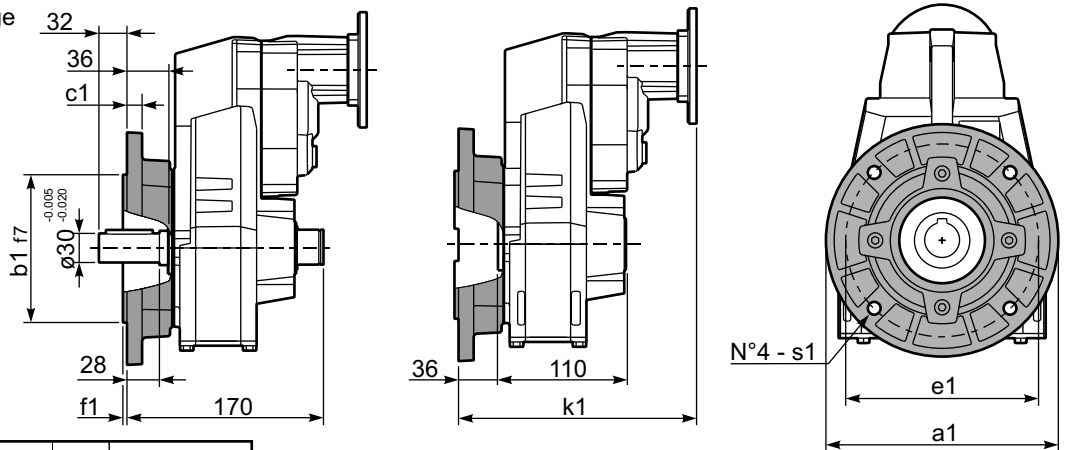

Available output flanges
Flange di uscita

a1 ø	b1	c1	e1	f1	s1	Kit code
160	110	10	130	3	9	KX5A.9.010
200	130	13	165	3.5	11	KX5A.9.011
250	180	14	215	4	14	KX5A.9.012

RFA43C... Input Shaft
Albero in entrata

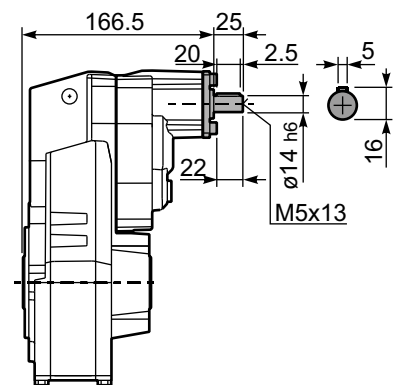

PFA43 A... Single output shaft
Albero uscita semplice

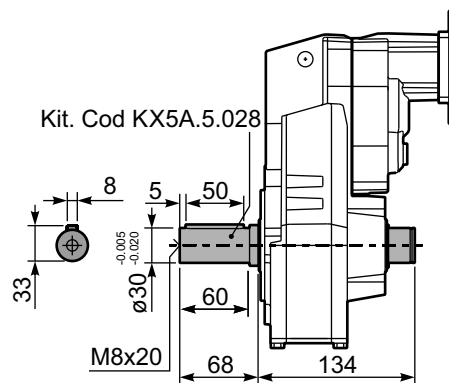

PFA43D... Shrink disk
Calettatore

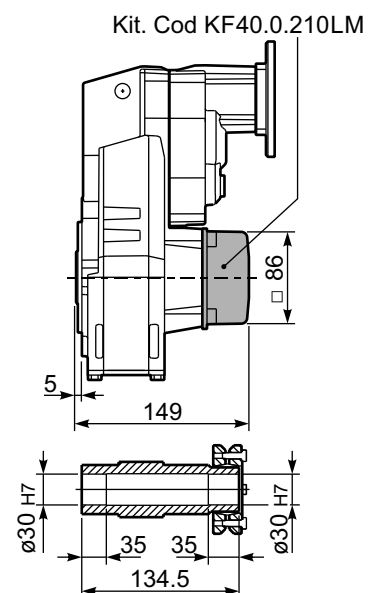



QUICK SELECTION / Selezione veloce

input speed (n_1) = 1400 min⁻¹

Output Speed n_2 [min ⁻¹]	Ratio i	Motor power P_{1M} [kW]	Output torque M_{2M} [Nm]	Service factor $f.s.$	Nominal power P_{1R} [kW]	Nominal torque M_{2R} [Nm]	Available B5 motor flanges					Available B14 motor flanges				Output Shaft 	Ratios code
							-C	-D	-E	-F	-G	-R	-T	-U	-V		
							71	80	90	100 112	132	80	90	100 112	132		
213	6.57	5.5	230	1.2	6.5	280	B									3018	01
185	7.56	5.5	265	1.1	5.9	290	B									3016	02
159	8.82	5.5	309	1.0	5.5	320	B									3014	03
113	12.39	5.5	434	1.0	5.5	450	B									2018	04
98	14.24	5.5	499	0.9	4.8	450	B									2016	05
84	16.75	4	429	1.1	4.3	470	B									1618	06
73	19.25	4	494	1.0	3.9	490	B									1616	07
64	21.78	4	558	0.9	3.4	490	B									1318	08
56	25.04	3	483	1.0	3.0	490	B									1316	09
47.9	29.23	3	564	0.9	2.6	490	B									1314	10
45.7	30.65	2.2	436	1.1	2.4	490	B									1116	11
39.1	35.78	2.2	509	1.0	2.1	490	B									1114	12
36.3	38.55	2.2	548	0.9	1.9	490	B									818	13
31.6	44.32	1.5	434	1.1	1.7	490	B									816	14
27.1	51.74	1.5	507	1.0	1.4	490	B									814	15
22.9	61.03	1.1	437	1.1	1.2	480	B									616	16
19.6	71.25	1.1	510	1.0	1.1	490	B									614	17

The dynamic efficiency is **0.96** for all ratios

Motor Flanges Available
Flange Motore Disponibili

B) Supplied with Reduction Bushing
Fornito con Bussola di Riduzione

B) Available on Request without reduction bushing
Disponibile a Richiesta senza Bussola di Riduzione

C) Motor Flange Holes Position
Posizione Fori Flangia Motore

EN Unit **FA52** is supplied with synthetic oil for lifetime lubrication, no maintenance is necessary. See table 1 for lubrication and recommended quantity. In table 2 please see possible radial loads and axial loads on the gearbox.

I Il riduttore **FA52** viene fornito completo di olio sintetico per la lubrificazione permanente e non necessita di alcuna manutenzione. Vedi tab.1 per oli e quantità consigliati. In tab.2 sono presenti i carichi radiali e assiali applicabili al riduttore.

D Das Getriebe **FA52** ist mit synthetischem Öl gefüllt und ist lebensdauergeschmiert. In Tabelle 1 ist die Schmiermenge und das empfohlene Schmiermittel angegeben. In Tabelle 2 sind die zulässigen Radial - und Axialbelastungen des Getriebes aufgeführt.

F Le réducteur **FA52** est fourni complet avec de l'huile synthétique pour la lubrification permanente et ne nécessite aucun entretien. Voir tableau 1 concernant les huiles et les quantités conseillées. Les charges radiales et axiales applicables au réducteur sont précisées dans le tableau 2.

E El reductor tamaño **FA52** se suministra, lubricado de por vida con aceite sintético y no requieren mantenimiento alguna. Ver tabla 1, para cantidades y aceites recomendados. En la tabla 2, se encuentran las cargas radiales y axiales admitidas por el reductor.

Standard supplied	For these mounting position specify in the order or add oil Per queste posizioni specificare in fase d'ordine o aggiungere olio				
1.85 LT	1.15 LT	1.15 LT	1.30 LT	2.10 LT	1.30 LT
SHELL Omala S4 WE 320			ENI Telium VSF 320		

For all details on lubrication and plugs check our website **tab. 1**
Per maggiori dettagli su lubrificazione e tappi olio vedi il nostro sito web

RADIAL AND AXIAL LOADS

Output shaft
Albero di uscita

$F_{eq} = FR \cdot \frac{149.5}{X+119.5}$

n_2	FA	FR	n_2	FA	FR	n_2	FA	FR
300	400	2000	140	460	2300	70	580	2900
250	420	2100	120	500	2500	40	780	3900
200	440	2200	85	550	2750	15	1140	5700

On request reinforced bearings to increase loads.
A richiesta cuscinetti rinforzati per aumentare i carichi.

Input shaft
Albero in entrata

n_1	FA	FR
1400	400	2000
900	440	2200
500	440	2200

tab. 2

PFA52C... Basic gearbox
Riduttore base

Gearbox weight
peso riduttore **15.5 kg**

M. flanges	Kit code	øF	A
71B5	K023.4.041	160	227
80/90B5	K023.4.042	200	229
100/112B5	K023.4.043	250	238
132B5	KC51.4.043	300	259
80B14	K085.4.046	120	229
90B14	K085.4.045	140	229
100/112B14	K085.4.047	160	238
132B14	KC51.4.041	200	259

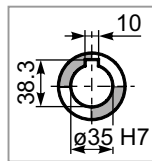
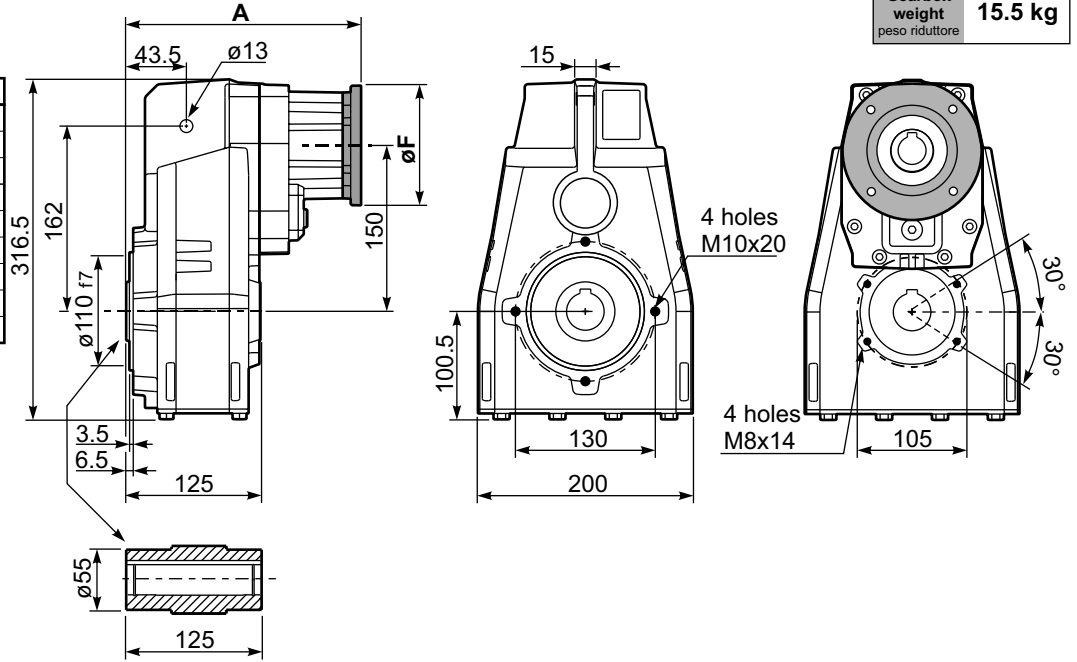

Standard
Hollow shaft

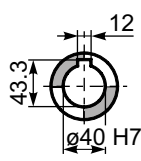

On request
A richiesta

PFA52...-F... Output flange
Flangia uscita

M. flanges	k1
71B5	260
80/90B5	262
100/112B5	271
132B5	289
80B14	262
90B14	262
100/112B14	271
132B14	289

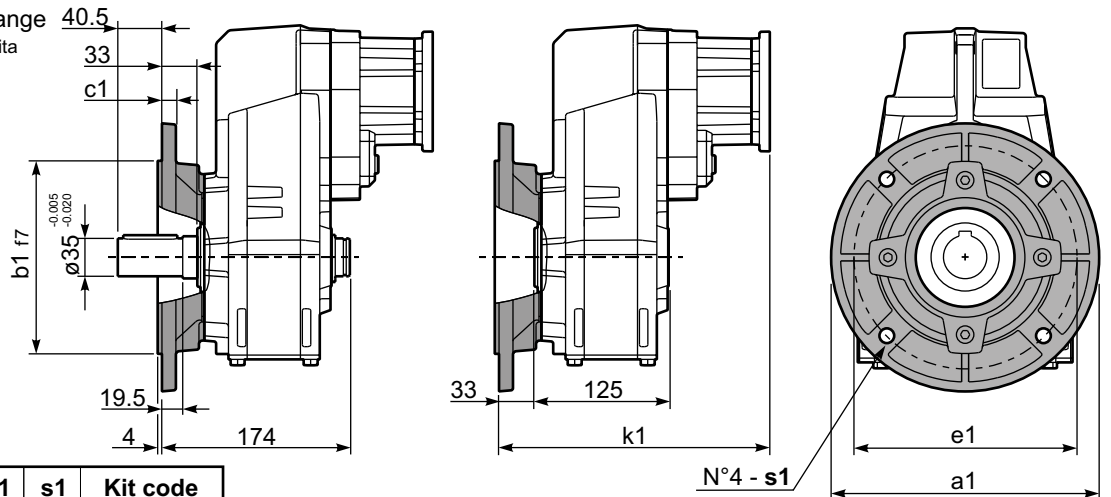

Available output flanges
Flange di uscita

a1 ø	b1	c1	e1	s1	Kit code
250	180	13	215	14	KF60.9.011
-	-	-	-	-	-

RFA52C... Input Shaft
Albero in entrata

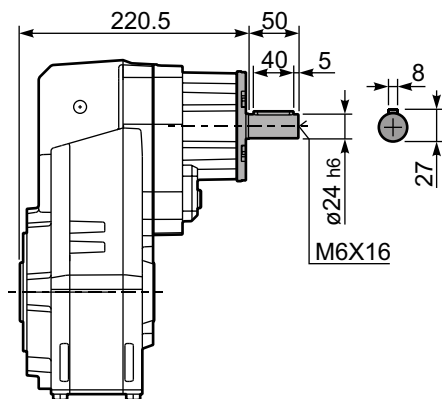

PFA52 A... Single output shaft
Albero uscita semplice

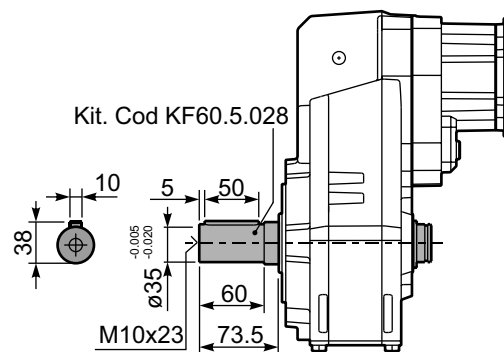

PFA52D... Shrink disk
Calettatore

Kit. Cod KF60.0.210LM

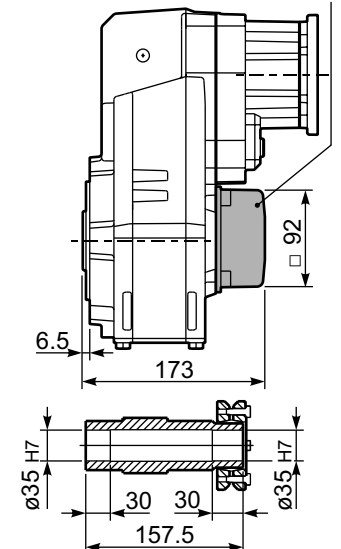



QUICK SELECTION / Selezione veloce

input speed (n_1) = 1400 min⁻¹

Output Speed n_2 [min ⁻¹]	Ratio i	Motor power P_{1M} [kW]	Output torque M_{2M} [Nm]	Service factor f.s.	Nominal power P_{1R} [kW]	Nominal torque M_{2R} [Nm]	Available B5 motor flanges				Available B14 motor flanges			Output Shaft 	Ratios code
							-B	-C	-D	-E	-Q	-R	-T		
							63	71	80	90	71	80	90		
22.6	61.89	1.1	434	1.2	1.3	510	B				C	C		191318	01
19.7	71.16	1.1	499	1.0	1.1	510	B				C	C		191316	02
17.0	82.48	1.1	578	0.9	0.96	510	B				C	C		171316	03
14.5	96.29	0.75	463	1.1	0.83	510	B				C	C		171314	04
13.9	100.51	0.75	483	1.1	0.79	510	B				C	C		131318	05
12.1	115.56	0.55	410	1.2	0.69	510	B				C	C		131316	06
11.1	125.96	0.55	447	1.1	0.63	510	B				C	C		190816	07
10.4	134.91	0.55	479	1.1	0.59	510	B				C	C		131314	08
9.5	147.05	0.55	522	1.0	0.54	510	B				C	C		190814	09
8.2	170.44	0.37	404	1.3	0.47	510	B				C	C		170814	10
7.6	184.15	0.37	437	1.2	0.43	510	B				C	C		101314	11
6.8	205.87	0.37	488	1.0	0.39	510	B				C	C		91316	12
5.8	240.34	0.37	570	0.9	0.33	510	B				C	C		91314	13
5.0	279.22	0.25	447	1.1	0.28	510	B				C	C		100816	14
4.3	325.97	0.25	522	1.0	0.24	510	B				C	C		100814	15
3.8	364.41	0.18	446	1.1	0.22	510	B				C	C		90816	16
3.3	425.43	0.18	521	1.0	0.19	510	B				C	C		90814	17
2.9	481.19	0.18	589	0.9	0.17	510	B				C	C		70816	18
2.5	561.76	0.12	444	1.1	0.14	510	B				C	C		70814	19

The dynamic efficiency is **0.94** for all ratios

- Motor Flanges Available** Flange Motore Disponibili
- B) Supplied with Reduction Bushing** Fornito con Bussola di Riduzione
- B) Available on Request without reduction bushing** Disponibile a Richiesta senza Bussola di Riduzione
- C) Motor Flange Holes Position** Posizione Fori Flangia Motore

EN Unit **FA53** is supplied with synthetic oil for lifetime lubrication, no maintenance is necessary. See table 1 for lubrication and recommended quantity. In table 2 please see possible radial loads and axial loads on the gearbox.

I Il riduttore **FA53** viene fornito completo di olio sintetico per la lubrificazione permanente e non necessita di alcuna manutenzione. Vedi tab.1 per oli e quantità consigliati. In tab.2 sono presenti i carichi radiali e assiali applicabili al riduttore.

D Das Getriebe **FA53** ist mit synthetischem Öl gefüllt und ist lebensdauergeschmiert. In Tabelle 1 ist die Schmiermenge und das empfohlene Schmiermittel angegeben. In Tabelle 2 sind die zulässigen Radial - und Axialbelastungen des Getriebes aufgeführt.

F Le réducteur **FA53** est fourni complet avec de l'huile synthétique pour la lubrification permanente et ne nécessite aucun entretien. Voir tableau 1 concernant les huiles et les quantités conseillées. Les charges radiales et axiales applicables au réducteur sont précisées dans le tableau 2.

E El reductor tamaño **FA53** se suministra, lubricado de por vida con aceite sintético y no requieren mantenimiento alguna. Ver tabla 1, para cantidades y aceites recomendados. En la tabla 2, se encuentran las cargas radiales y axiales admitidas por el reductor.

Standard supplied	For these mounting position specify in the order or add oil Per queste posizioni specificare in fase d'ordine o aggiungere olio				
2.15 LT	1.25 LT	1.25 LT	1.45 LT	2.35 LT	1.45 LT
SHELL Omala S4 WE 320			ENI Telium VSF 320		

For all details on lubrication and plugs check our website **tab. 1**
Per maggiori dettagli su lubrificazione e tappi olio vedi il nostro sito web

RADIAL AND AXIAL LOADS

Output shaft
Albero di uscita

$F_{eq} = F_R \cdot \frac{149.5}{X+119.5}$

n_2	FA	FR	n_2	FA	FR	n_2	FA	FR
300	400	2000	140	460	2300	70	580	2900
250	420	2100	120	500	2500	40	780	3900
200	440	2200	85	550	2750	15	1140	5700

On request reinforced bearings to increase loads.
A richiesta cuscinetti rinforzati per aumentare i carichi.

Input shaft
Albero in entrata

n_1	FA	FR
1400	240	1200
900	280	1400
500	340	1700

tab. 2

PFA53C... Basic gearbox
Riduttore base

Gearbox weight
peso riduttore **15.5 kg**

M. flanges	Kit code	øF	A
63B5	K063.4.041	140	239
71B5	K063.4.042	160	237
80/90B5	K063.4.043	200	
71B14	K063.4.047	105	237
80B14	K063.4.046	120	239
90B14	K063.4.041	140	239

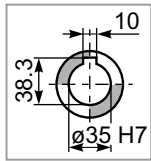
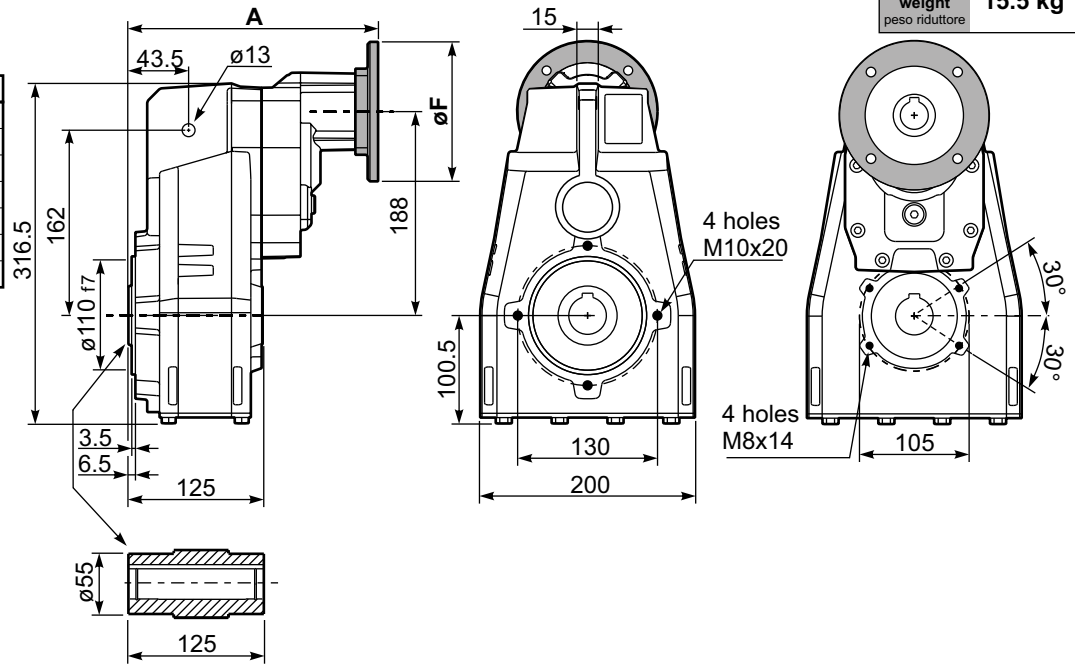

Standard
Hollow shaft

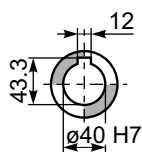

On request
A richiesta

PFA53...-F... Output flange
Flangia uscita

Motor Flange	k1
63B5	272
71B5	270
80/90B5	272
71B14	270
80B14	272
90B14	272

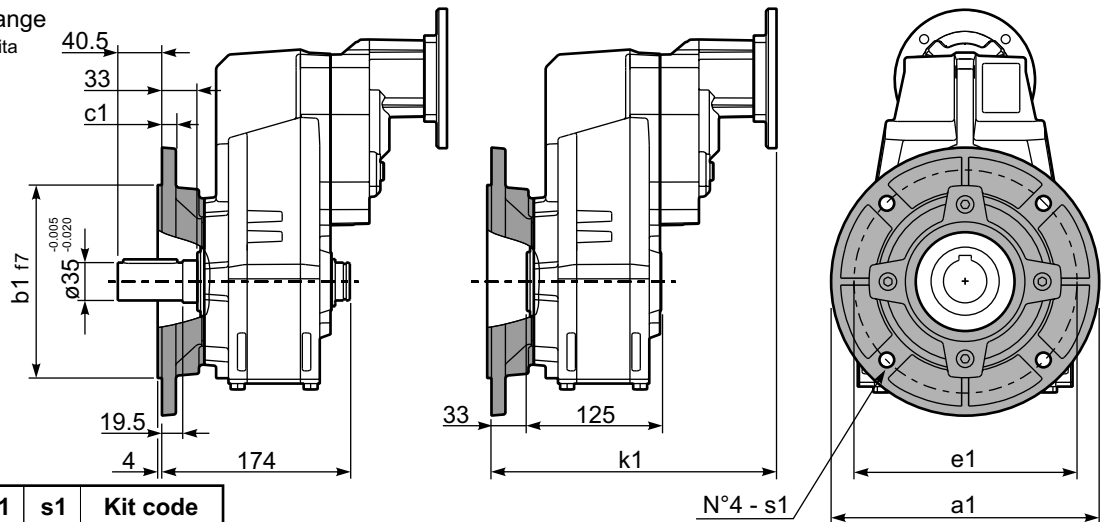

Available output flanges
Flange di uscita

a1 ø	b1	c1	e1	s1	Kit code
250	180	13	215	14	KF60.9.011
-	-	-	-	-	-

RFA53C... Input Shaft
Albero in entrata

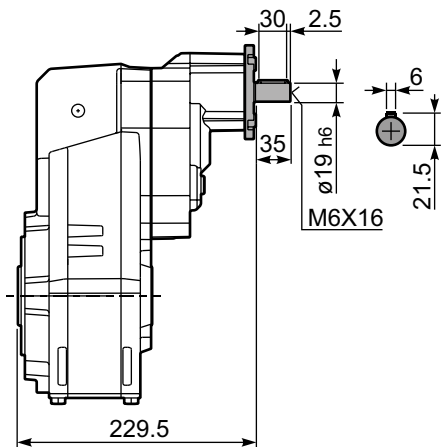

PFA53 A... Single output shaft
Albero uscita semplice

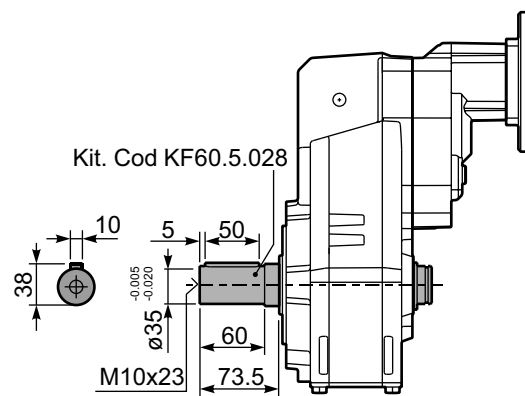

PFA53D... Shrink disk
Calettatore

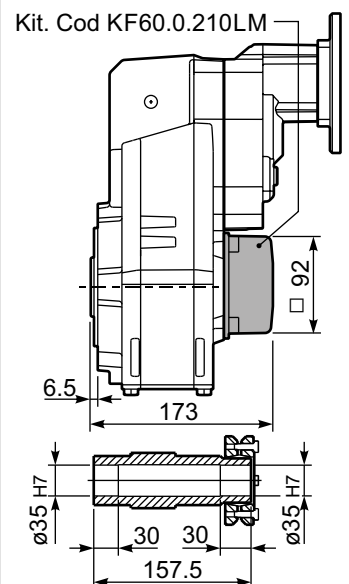



QUICK SELECTION / Selezione veloce

input speed (n_1) = 1400 min⁻¹

Output Speed n_2 [min ⁻¹]	Ratio i	Motor power P_{1M} [kW]	Output torque M_{2M} [Nm]	Service factor f.s.	Nominal power P_{1R} [kW]	Nominal torque M_{2R} [Nm]	Available B5 motor flanges		B14 motor flanges				Output Shaft		
							-G	132	-	-	-	-	-	-	
507	2.76	9	166	1.6	14.4	265			not available				2980	standard	01
395	3.54	9	213	1.3	11.6	275							2485	ø35	02
277	5.06	9	304	1.0	8.6	290							1891		03
241	5.81	7.5	281	1.2	8.5	330							1693	ø40	04
206	6.79	7.5	329	1.2	8.4	380							1495	On request	05

The dynamic efficiency is **0.98** for all ratios

A) Motor Flanges Available
Flange Motore Disponibili

B) Supplied with Reduction Bushing
Fornito con Bussola di Riduzione

B) Available on Request without reduction bushing
Disponibile a Richiesta senza Bussola di Riduzione

C) Motor Flange Holes Position
Posizione Fori Flangia Motore

EN Unit **FC61** is supplied with synthetic oil for lifetime lubrication, no maintenance is necessary. See table 1 for lubrication and recommended quantity. In table 2 please see possible radial loads and axial loads on the gearbox.

I Il riduttore **FC61** viene fornito completo di olio sintetico per la lubrificazione permanente e non necessita di alcuna manutenzione. Vedi tab.1 per oli e quantità consigliati. In tab.2 sono presenti i carichi radiali e assiali applicabili al riduttore.

D Das Getriebe **FC61** ist mit synthetischem Öl gefüllt und ist lebensdauergeschmiert. In Tabelle 1 ist die Schmiermenge und das empfohlene Schmiermittel angegeben. In Tabelle 2 sind die zulässigen Radial - und Axialbelastungen des Getriebes aufgeführt.

F Le réducteur **FC61** est fourni complet avec de l'huile synthétique pour la lubrification permanente et ne nécessite aucun entretien. Voir tableau 1 concernant les huiles et les quantités conseillées. Les charges radiales et axiales applicables au réducteur sont précisées dans le tableau 2.

E El reductor tamaño **FC61** se suministra, lubricado de por vida con aceite sintético y no requieren mantenimiento alguna. Ver tabla 1, para cantidades y aceites recomendados. En la tabla 2, se encuentran las cargas radiales y axiales admitidas por el reductor.

Standard supplied	For these mounting position specify in the order or add oil Per queste posizioni specificare in fase d'ordine o aggiungere olio				
H1	H4	H3	H2	H5	H6
2.05 LT	1.25 LT	1.25 LT	1.40 LT	2.05 LT	1.40 LT
SHELL Omala S4 WE 320			ENI Telium VSF 320		

For all details on lubrication and plugs check our website **tab. 1**
Per maggiori dettagli su lubrificazione e tappi olio vedi il nostro sito web

RADIAL AND AXIAL LOADS

Output shaft
Albero di uscita

$F_{eq} = F_R \cdot \frac{149.5}{X+119.5}$

n_2	FA	FR	n_2	FA	FR	n_2	FA	FR
300	600	3000	140	720	3600	70	940	4700
250	640	3200	120	740	3700	40	1220	6100
200	690	3460	85	860	4300	15	1300	6500

On request reinforced bearings to increase loads.
A richiesta cuscinetti rinforzati per aumentare i carichi.

tab. 2

PFC61C...

Basic gearbox
Riduttore base

Gearbox weight
peso riduttore **31.0 kg**

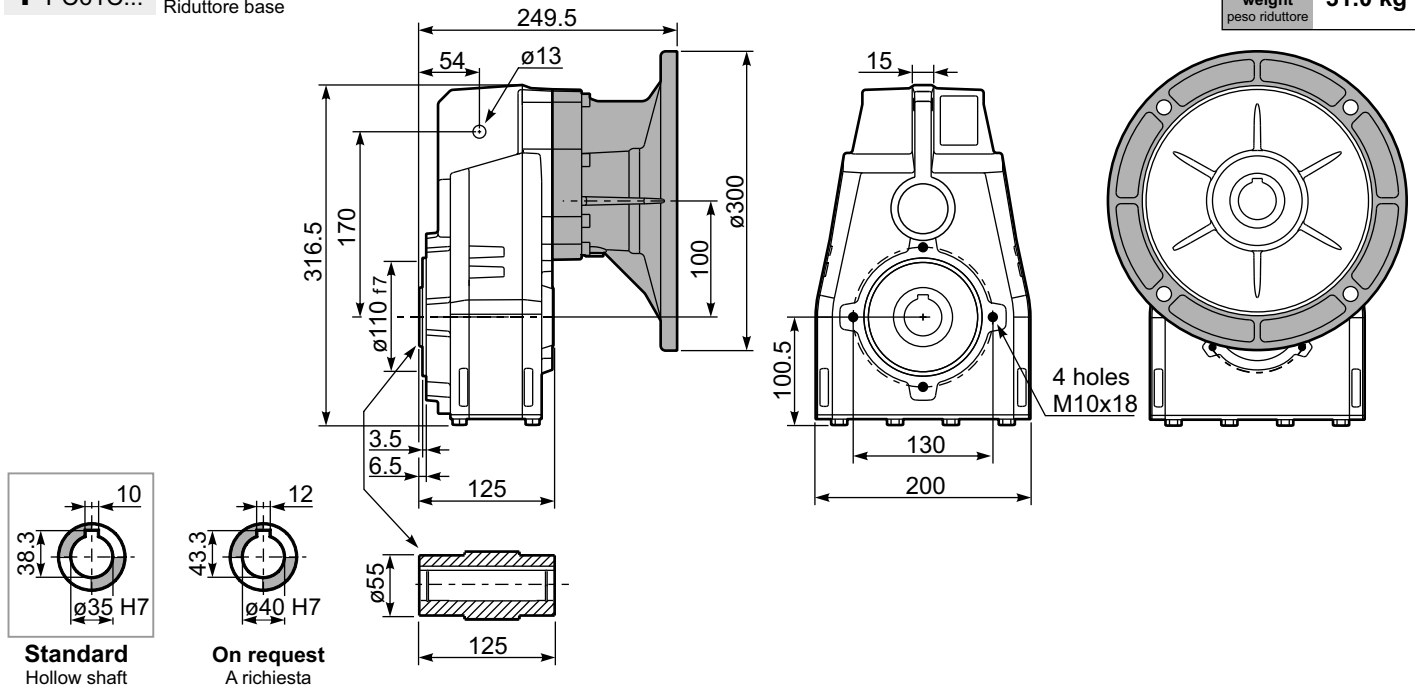

PFC61...-F...

Output flange
Flangia uscita

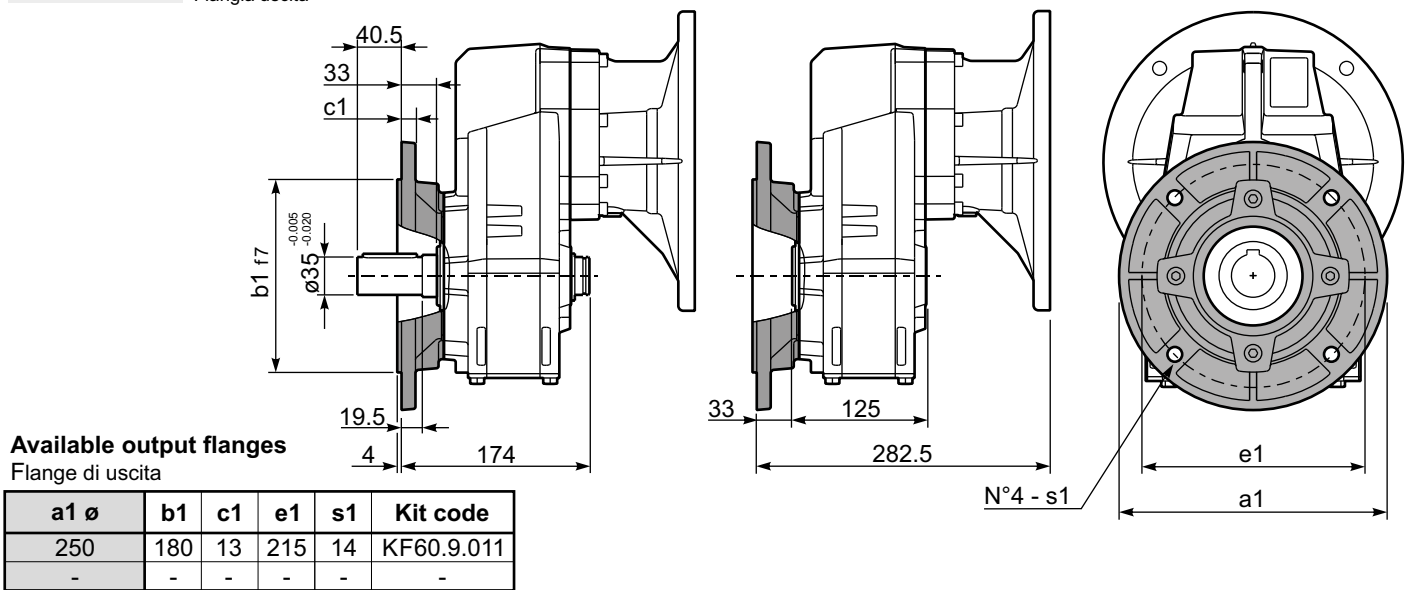

PFC61 A...

Single output shaft
Albero uscita semplice

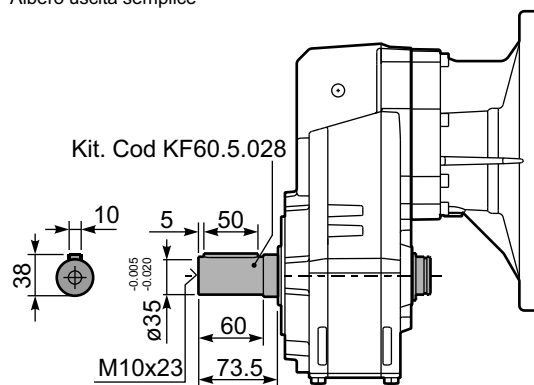



QUICK SELECTION / Selezione veloce input speed (n₁) = 1400 min⁻¹

Output Speed n ₂ [min ⁻¹]	Ratio i	Motor power P _{1M} [kW]	Output torque M _{2M} [Nm]	Service factor f.s.	Nominal power P _{1R} [kW]	Nominal torque M _{2R} [Nm]	Available B5 motor flanges					Available B14 motor flanges				Output Shaft 	Ratios code	
							-C	-D	-E	-F	-G	-R	-T	-U	-V			
							71	80	90	100 112	132	80	90	100 112	132			
213	6.57	7.5	312	1.2	8.8	380	B										3018	01
185	7.56	7.5	358	1.1	7.9	390	B										3016	02
159	8.82	7.5	419	1.0	7.1	410	B										3014	03
113	12.39	7.5	588	1.0	7.2	580	B										2018	04
98	14.24	5.5	499	1.2	6.4	600	B										2016	05
84	16.75	5.5	587	1.1	6.1	665	B										1618	06
73	19.25	5.5	675	1.0	5.4	675	B										1616	07
64	21.78	4	558	1.2	4.7	675	B										1318	08
56	25.04	4	642	1.1	4.1	675	B										1316	09
47.9	29.23	4	750	0.9	3.5	675	B										1314	10
45.7	30.65	3	592	1.1	3.4	675	B										1116	11
39.1	35.78	3	691	1.0	2.9	675	B										1114	12
36.3	38.55	2.2	548	1.1	2.3	580	B										818	13
31.6	44.32	2.2	630	1.1	2.3	665	B										816	14
27.1	51.74	2.2	735	0.9	2.0	675	B										814	15
22.9	61.03	1.1	437	1.1	1.2	480	B										616	16
19.6	71.25	1.1	510	1.1	1.2	560	B										614	17

The dynamic efficiency is **0.96** for all ratios

Motor Flanges Available Flange Motore Disponibili
B) Supplied with Reduction Bushing Fornito con Bussola di Riduzione
B) Available on Request without reduction bushing Disponibile a Richiesta senza Bussola di Riduzione
C) Motor Flange Holes Position Posizione Fori Flangia Motore

EN Unit **FC62** is supplied with synthetic oil for lifetime lubrication, no maintenance is necessary. See table 1 for lubrication and recommended quantity. In table 2 please see possible radial loads and axial loads on the gearbox.

I Il riduttore **FC62** viene fornito completo di olio sintetico per la lubrificazione permanente e non necessita di alcuna manutenzione. Vedi tab.1 per oli e quantità consigliati. In tab.2 sono presenti i carichi radiali e assiali applicabili al riduttore.

D Das Getriebe **FC62** ist mit synthetischem Öl gefüllt und ist lebensdauergeschmiert. In Tabelle 1 ist die Schmiermenge und das empfohlene Schmiermittel angegeben. In Tabelle 2 sind die zulässigen Radial - und Axialbelastungen des Getriebes aufgeführt.

F Le réducteur **FC62** est fourni complet avec de l'huile synthétique pour la lubrification permanente et ne nécessite aucun entretien. Voir tableau 1 concernant les huiles et les quantités conseillées. Les charges radiales et axiales applicables au réducteur sont précisées dans le tableau 2.

E El reductor tamaño **FC62** se suministra, lubricado de por vida con aceite sintético y no requieren mantenimiento alguna. Ver tabla 1, para cantidades y aceites recomendados. En la tabla 2, se encuentran las cargas radiales y axiales admitidas por el reductor.

Standard supplied	For these mounting position specify in the order or add oil Per queste posizioni specificare in fase d'ordine o aggiungere olio				
2.05 LT	1.25 LT	1.25 LT	1.40 LT	2.20 LT	1.40 LT
SHELL Omala S4 WE 320			ENI Telium VSF 320		

For all details on lubrication and plugs check our website tab. 1
Per maggiori dettagli su lubrificazione e tappi olio vedi il nostro sito web

RADIAL AND AXIAL LOADS

Output shaft
Albero di uscita

$F_{eq} = FR \cdot \frac{149.5}{X+119.5}$

n ₂	FA	FR	n ₂	FA	FR	n ₂	FA	FR
300	600	3000	140	720	3600	70	940	4700
250	640	3200	120	740	3700	40	1220	6100
200	690	3460	85	860	4300	15	1300	6500

On request reinforced bearings to increase loads.
A richiesta cuscinetti rinforzati per aumentare i carichi.

Input shaft
Albero in entrata

n ₁	FA	FR
1400	450	2250
900	500	2500
500	600	3000

tab. 2

PFC62C... Basic gearbox
Riduttore base

Gearbox weight
peso riduttore **20.8 kg**

M. flanges	Kit code	øF	A
71B5	K023.4.041	160	227
80/90B5	K023.4.042	200	229
100/112B5	K023.4.043	250	238
132B5	KC51.4.043	300	259
80B14	K085.4.046	120	229
90B14	K085.4.045	140	229
100/112B14	K085.4.047	160	238
132B14	KC51.4.041	200	259

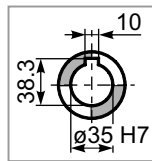
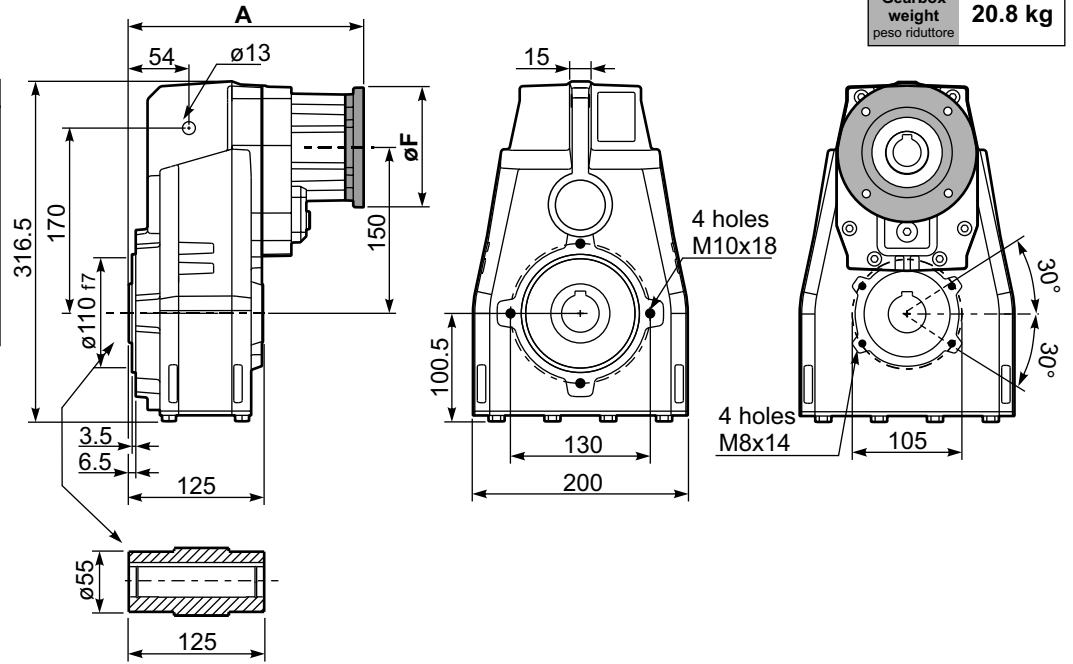

Standard
Hollow shaft

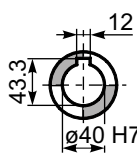

On request
A richiesta

PFC62...-F... Output flange
Flangia uscita

M. flanges	k1
71B5	260
80/90B5	262
100/112B5	271
132B5	289
80B14	262
90B14	262
100/112B14	271
132B14	289

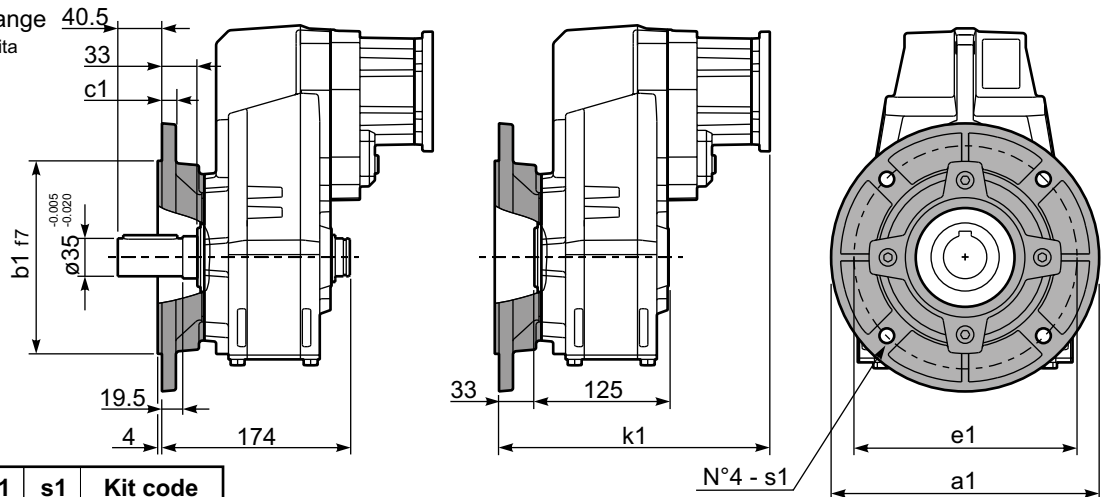

Available output flanges
Flange di uscita

a1 ø	b1	c1	e1	s1	Kit code
250	180	13	215	14	KF60.9.011
-	-	-	-	-	-

RFC62C... Input Shaft
Albero in entrata

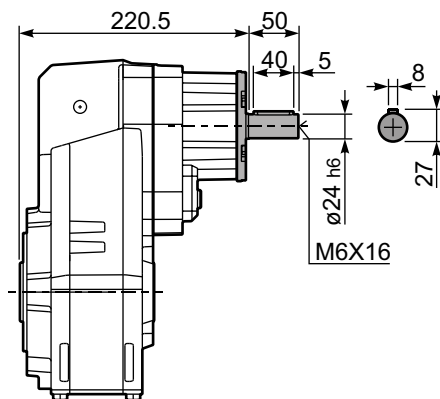

PFC62 A... Single output shaft
Albero uscita semplice

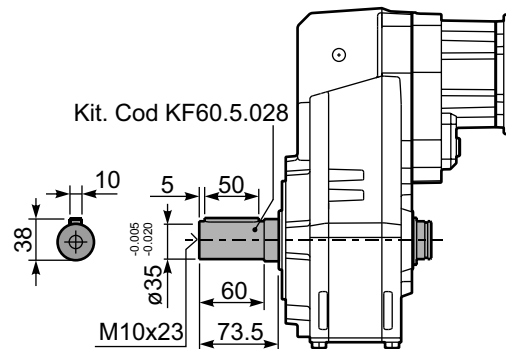

PFC62D... Shrink disk
Calettatore

Kit. Cod KF60.0.210LM

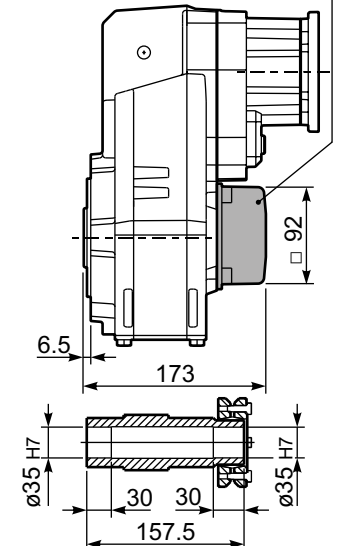



QUICK SELECTION / Selezione veloce

input speed (n_1) = 1400 min⁻¹

Output Speed n_2 [min ⁻¹]	Ratio i	Motor power P_{1M} [kW]	Output torque M_{2M} [Nm]	Service factor f.s.	Nominal power P_{1R} [kW]	Nominal torque M_{2R} [Nm]	Available B5 motor flanges				Available B14 motor flanges			Output Shaft 	Ratios code
							-B	-C	-D	-E	-Q	-R	-T		
							63	71	80	90	71	80	90		
22.6	61.89	1.5	594	1.1	1.7	675	B				C	C		191318	01
19.7	71.16	1.5	683	1.0	1.5	675	B				C	C		191316	02
17.0	82.48	1.5	792	0.9	1.3	675	B				C	C		171316	03
14.5	96.29	1.1	675	1.0	1.1	675	B				C	C		171314	04
13.9	100.51	1.1	705	1.0	1.0	675	B				C	C		131318	05
12.1	115.56	0.75	556	1.2	0.91	675	B				C	C		131316	06
11.1	125.96	0.75	606	1.1	0.82	665	B				C	C		190816	07
10.4	134.91	0.75	649	1.0	0.78	675	B				C	C		131314	08
9.5	147.05	0.75	707	1.0	0.72	675	B				C	C		190814	09
8.2	170.44	0.55	605	1.1	0.62	675	B				C	C		170814	10
7.6	184.15	0.55	653	1.0	0.57	675	B				C	C		101314	11
6.8	205.87	0.55	730	0.9	0.51	675	B				C	C		91316	12
5.8	240.34	0.37	570	1.2	0.44	675	B				C	C		91314	13
5.0	279.22	0.37	662	1.0	0.37	665	B				C	C		100816	14
4.3	325.97	0.37	773	0.9	0.32	675	B				C	C		100814	15
3.8	364.41	0.25	583	1.1	0.28	665	B				C	C		90816	16
3.3	425.43	0.25	681	1.0	0.25	675	B				C	C		90814	17
2.9	481.19	0.18	589	1.1	0.22	665	B				C	C		70816	18
2.5	561.76	0.18	687	1.0	0.19	675	B				C	C		70814	19

The dynamic efficiency is **0.94** for all ratios

Motor Flanges Available Flange Motore Disponibili
 B) Supplied with Reduction Bushing Fornito con Bussola di Riduzione
 B) Available on Request without reduction bushing Disponibile a Richiesta senza Bussola di Riduzione
 C) Motor Flange Holes Position Posizione Fori Flangia Motore

EN Unit **FC63** is supplied with synthetic oil for lifetime lubrication, no maintenance is necessary. See table 1 for lubrication and recommended quantity. In table 2 please see possible radial loads and axial loads on the gearbox.

I Il riduttore **FC63** viene fornito completo di olio sintetico per la lubrificazione permanente e non necessita di alcuna manutenzione. Vedi tab.1 per oli e quantità consigliati. In tab.2 sono presenti i carichi radiali e assiali applicabili al riduttore.

D Das Getriebe **FC63** ist mit synthetischem Öl gefüllt und ist lebensdauergeschmiert. In Tabelle 1 ist die Schmiermenge und das empfohlene Schmiermittel angegeben. In Tabelle 2 sind die zulässigen Radial - und Axialbelastungen des Getriebes aufgeführt.

F Le réducteur **FC63** est fourni complet avec de l'huile synthétique pour la lubrification permanente et ne nécessite aucun entretien. Voir tableau 1 concernant les huiles et les quantités conseillées. Les charges radiales et axiales applicables au réducteur sont précisées dans le tableau 2.

E El reductor tamaño **FC63** se suministra, lubricado de por vida con aceite sintético y no requieren mantenimiento alguna. Ver tabla 1, para cantidades y aceites recomendados. En la tabla 2, se encuentran las cargas radiales y axiales admitidas por el reductor.

Standard supplied	For these mounting position specify in the order or add oil Per queste posizioni specificare in fase d'ordine o aggiungere olio				
2.30 LT	1.35 LT	1.35 LT	1.55 LT	2.45 LT	1.55 LT
SHELL Omala S4 WE 320			ENI Telium VSF 320		

For all details on lubrication and plugs check our website **tab. 1**
Per maggiori dettagli su lubrificazione e tappi olio vedi il nostro sito web

RADIAL AND AXIAL LOADS

Output shaft
Albero di uscita

$F_{eq} = FR \cdot \frac{149.5}{X+119.5}$

n_2	FA	FR	n_2	FA	FR	n_2	FA	FR
300	600	3000	140	720	3600	70	940	4700
250	640	3200	120	740	3700	40	1220	6100
200	690	3460	85	860	4300	15	1300	6500

On request reinforced bearings to increase loads.
A richiesta cuscinetti rinforzati per aumentare i carichi.

Input shaft
Albero in entrata

n_1	FA	FR
1400	240	1200
900	280	1400
500	340	1700

tab. 2



QUICK SELECTION / Selezione veloce

input speed (n_1) = 1400 min⁻¹

Output Speed n_2 [min ⁻¹]	Ratio i	Motor power P_{1M} [kW]	Output torque M_{2M} [Nm]	Service factor f.s.	Nominal power P_{1R} [kW]	Nominal torque M_{2R} [Nm]	Available B5 motor flanges		B14 motor flanges				Output Shaft	
							-G	132	-	-	-	-	-	-
227	6.17	9	371	1.2	10.9	450			not available					
198	7.06	9	425	1.4	12.7	600			not available					
170	8.21	9	494	1.4	12.2	670			not available					

The dynamic efficiency is **0.98** for all ratios

A) Motor Flanges Available
Flange Motore Disponibili

B) Supplied with Reduction Bushing
Fornito con Bussola di Riduzione

B) Available on Request without reduction bushing
Disponibile a Richiesta senza Bussola di Riduzione

C) Motor Flange Holes Position
Posizione Fori Flangia Motore

EN Unit **FC71** is supplied without lubricant and equipped with a breather, level and drain plugs. User can add mineral oil keeping existing plugs. Should the user wish to fill it with synthetic oil, it is recommended to replace the existing plugs with a closed plug. See table 1 for lubrication and recommended quantity. In table 2 please see possible radial loads and axial loads on the gearbox.

I Il riduttore tipo **FC71** è fornito privo di lubrificazione con tappi di sfiato, livello e scarico olio. L'utente può immettere olio minerale mantenendo i tappi esistenti. Se immetterà olio sintetico, dovrà sostituire i tappi esistenti con altri tipo chiuso. Tab.1 per oli e quantità consigliati. Tab.2 carichi radiali e assiali applicabili al riduttore.

D Das Getriebe der Baugröße **FC71** wird ohne Schmiermittel geliefert. Es ist jedoch mit Einfüllschraube, Überdruckventil und Ablassschraube ausgerüstet. Das benötigte mineralische Öl kann über die Einfüllschraube eingefüllt werden. Sollte synthetisches Öl bevorzugt werden, so ist sind das eingebaute Überdruckventil durch eine geschlossenen Schraube zu ersetzen. In Tabelle 1 ist die Schmiermenge und das empfohlene Schmiermittel angegeben. In Tabelle 2 sind die zulässigen Radial - und Axialbelastungen des Getriebes aufgeführt.

F Le réducteur de type **FC71** est fourni sans lubrification et avec un bouchon de remplissage, de niveau et d'évacuation de l'huile. L'utilisateur peut y verser de l'huile minérale en conservant les bouchons existants. S'il y versera de l'huile synthétique, il devra substituer les bouchons existants avec d'autres bouchons de type fermé. Voir tableau 1 concernant les huiles et les quantités conseillées. Voir tableau 2 concernant les charges radiales et axiales applicables au réducteur

E El reductor tamaño **FC71** se suministra sin lubricante, provisto de tapones de respiración, nivel y descarga de aceite. El usuario puede utilizar aceite mineral, manteniendo los tapones existentes. Si prefiere utilizar aceite sintético deberá sustituir los tapones existentes por tapones ciegos. La prerreducción se suministra con tapones ciegos, lubricado de por vida con aceite sintético. Ver tabla 1, para cantidades y aceites recomendados. En la tabla 2, se encuentran las cargas radiales y axiales admitidas por el reductor.

H1	H4	H3	H2	H5	H6
3.30 LT	1.90 LT	1.90 LT	1.80 LT	3.30 LT	1.90 LT
SHELL Omala S2 GX 460			ENI Blasias 460		

For all details on lubrication and plugs check our website **tab. 1**
Per maggiori dettagli su lubrificazione e tappi olio vedi il nostro sito web

RADIAL AND AXIAL LOADS

Output shaft
Albero di uscita

$F_{eq} = F_R \cdot \frac{174.5}{X+134.5}$

n_2	FA	FR	n_2	FA	FR	n_2	FA	FR
300	740	3700	140	860	4300	70	1020	5100
250	800	4000	120	900	4500	40	1300	6500
200	830	4150	85	970	4850	15	1700	8500

On request reinforced bearings to increase loads.
A richiesta cuscinetti rinforzati per aumentare i carichi.

tab. 2

PFC71C...

Basic gearbox
Riduttore base

Gearbox weight
peso riduttore **35.0 kg**

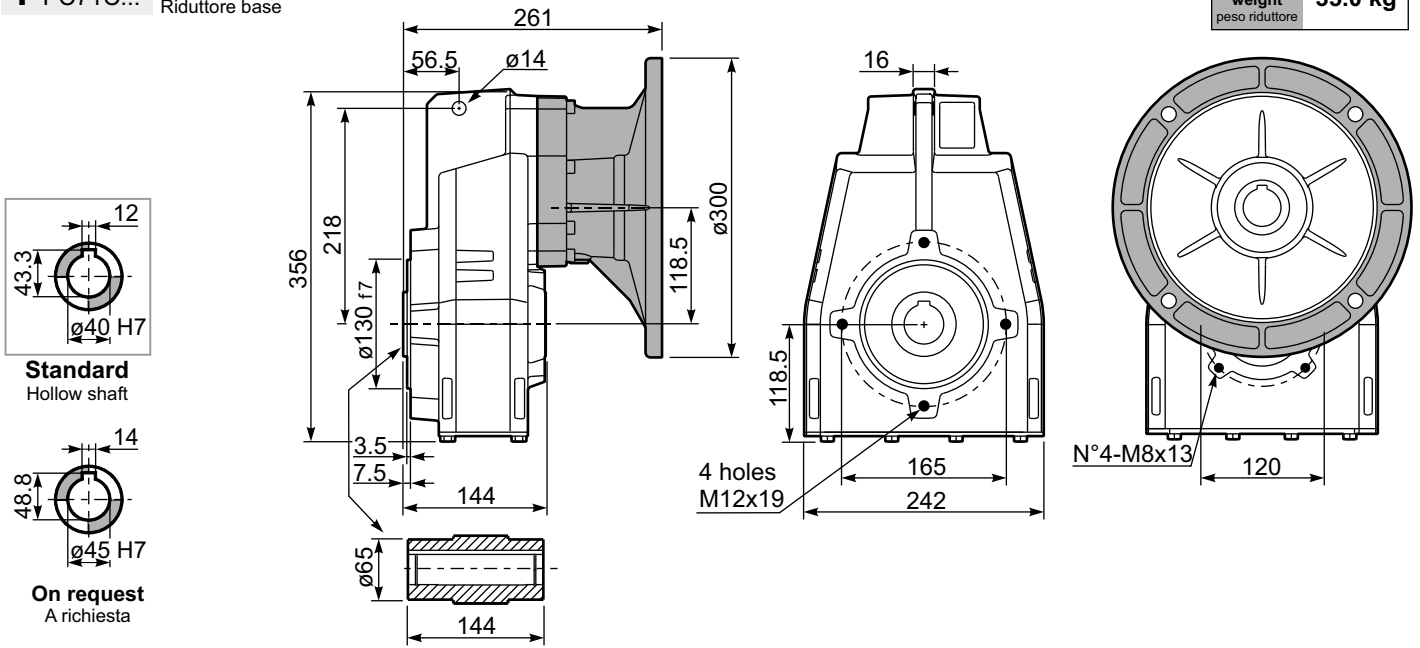

PFC71...-F...

Output flange
Flangia uscita

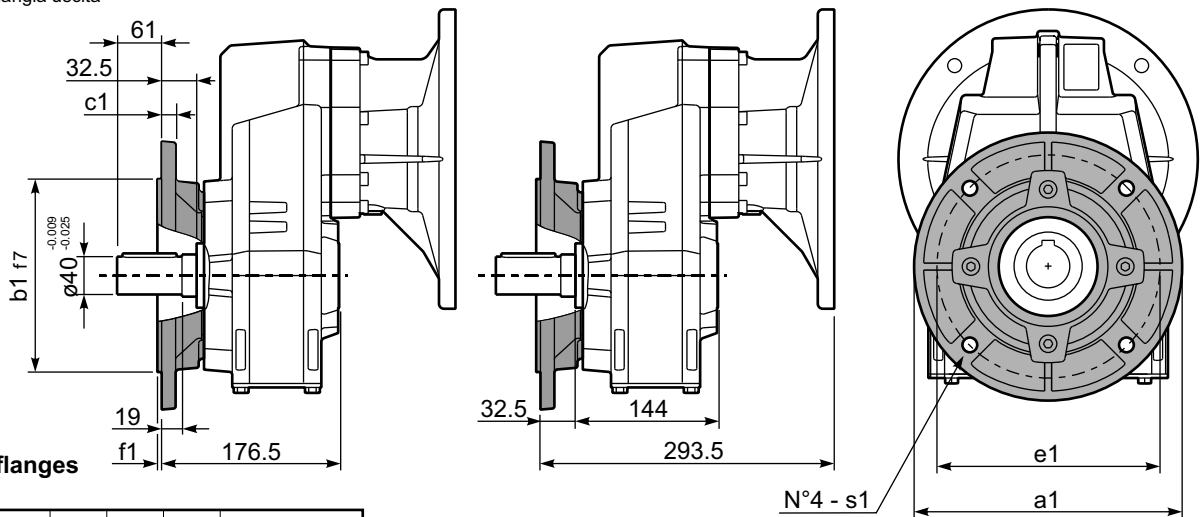

Available output flanges

Flange di uscita

a1	ø	b1	c1	e1	f1	s1	Kit code
250		180	13	215	3	14	KF70.9.011
300		230	16	265	4	14	KF70.9.012

PFC71 A...

Single output shaft
Albero uscita semplice

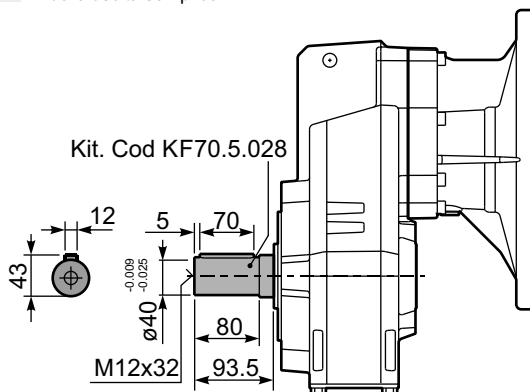



QUICK SELECTION / Selezione veloce

input speed (n_1) = 1400 min⁻¹

Output Speed n_2 [min ⁻¹]	Ratio i	Motor power P_{1M} [kW]	Output torque M_{2M} [Nm]	Service factor f.s.	Nominal power P_{1R} [kW]	Nominal torque M_{2R} [Nm]	Available B5 motor flanges					Available B14 motor flanges				Output Shaft 	Ratios code	
							-C	-D	-E	-F	-G	-R	-T	-U	-V			
							71	80	90	100 112	132	80	90	100 112	132			
175	8.02	9	473	1.1	9.9	520	B										3018	01
152	9.18	9	541	1.1	9.8	590	B										3016	02
131	10.68	9	630	1.1	9.7	680	B										3014	03
93	15.11	7.5	717	1.1	7.8	775	B										2018	04
81	17.30	7.5	821	1.1	7.8	885	B										2016	05
70	20.13	7.5	955	0.9	6.8	900	B										2014	06
60	23.39	5.5	820	1.1	5.9	900	B										1616	07
51	27.21	5.5	954	0.9	5.1	900	B										1614	08
46.0	30.42	4	780	1.2	4.5	900	B										1316	09
39.6	35.38	4	907	1.0	3.9	900	B										1314	10
37.6	37.24	3	719	1.2	3.7	895	B										1116	11
32.3	43.31	3	836	1.1	3.2	900	B										1114	12
29.8	47.02	2.2	668	1.1	2.3	705	B										818	13
26.0	53.85	2.2	765	1.1	2.3	810	B										816	14
22.4	62.63	2.2	890	1.0	2.2	900	B										814	15
18.9	74.16	1.1	531	1.1	1.2	585	B										616	16
16.2	86.25	1.1	617	1.1	1.2	680	B										614	17

The dynamic efficiency is **0.96** for all ratios

Motor Flanges Available
Flange Motore Disponibili

B) Supplied with Reduction Bushing
Fornito con Bussola di Riduzione

B) Available on Request without reduction bushing
Disponibile a Richiesta senza Bussola di Riduzione

C) Motor Flange Holes Position
Posizione Fori Flangia Motore

EN Unit **FC72** is supplied without lubricant and equipped with a breather, level and drain plugs. User can add mineral oil keeping existing plugs. Should the user wish to fill it with synthetic oil, it is recommended to replace the existing plugs with a closed plug. See table 1 for lubrication and recommended quantity. In table 2 please see possible radial loads and axial loads on the gearbox.

I Il riduttore tipo **FC72** è fornito privo di lubrificazione con tappi di sfiato, livello e scarico olio. L'utente può immettere olio minerale mantenendo i tappi esistenti. Se immetterà olio sintetico, dovrà sostituire i tappi esistenti con altri tipo chiuso. Tab.1 per oli e quantità consigliati. Tab.2 carichi radiali e assiali applicabili al riduttore.

D Das Getriebe der Baugröße **FC72** wird ohne Schmiermittel geliefert. Es ist jedoch mit Einfüllschraube, Überdruckventil und Ablassschraube ausgerüstet. Das benötigte mineralische Öl kann über die Einfüllschraube eingefüllt werden. Sollte synthetisches Öl bevorzugt werden, so ist sind das eingebaute Überdruckventil durch eine geschlossenen Schraube zu ersetzen. In Tabelle 1 ist die Schmiermenge und das empfohlene Schmiermittel angegeben. In Tabelle 2 sind die zulässigen Radial - und Axialbelastungen des Getriebes aufgeführt.

F Le réducteur de type **FC72** est fourni sans lubrification et avec un bouchon de remplissage, de niveau et d'évacuation de l'huile. L'utilisateur peut y verser de l'huile minérale en conservant les bouchons existants. S'il y versera de l'huile synthétique, il devra substituer les bouchons existants avec d'autres bouchons de type fermé. Voir tableau 1 concernant les huiles et les quantités conseillées. Voir tableau 2 concernant les charges radiales et axiales applicables au réducteur.

E El reductor tamaño **FC72** se suministra sin lubricante, provisto de tapones de respiración, nivel y descarga de aceite. El usuario puede utilizar aceite mineral, manteniendo los tapones existentes. Si prefiere utilizar aceite sintético deberá sustituir los tapones existentes por tapones ciegos. La prerreducción se suministra con tapones ciegos, lubricado de por vida con aceite sintético. Ver tabla 1, para cantidades y aceites recomendados. En la tabla 2, se encuentran las cargas radiales y axiales admitidas por el reductor.

H1	H4	H3	H2	H5	H6
3.50 LT	1.90 LT	1.90 LT	1.80 LT	3.60 LT	1.90 LT
SHELL Omala S2 GX 460			ENI Blasias 460		

For all details on lubrication and plugs check our website **tab. 1**
Per maggiori dettagli su lubrificazione e tappi olio vedi il nostro sito web

RADIAL AND AXIAL LOADS

Output shaft
Albero di uscita

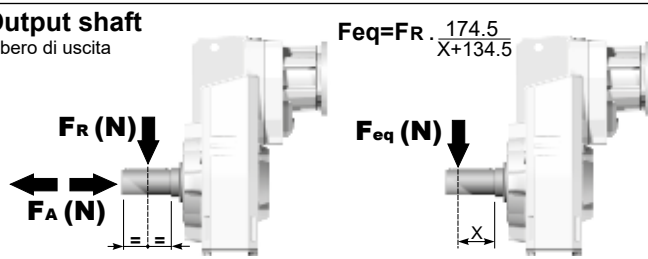

n_2	FA	FR	n_2	FA	FR	n_2	FA	FR
300	740	3700	140	860	4300	70	1020	5100
250	800	4000	120	900	4500	40	1300	6500
200	830	4150	85	970	4850	15	1700	8500

On request reinforced bearings to increase loads.
A richiesta cuscinetti rinforzati per aumentare i carichi.

Input shaft
Albero in entrata

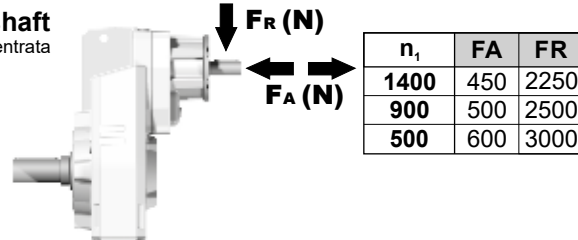

tab. 2

PFC72C... Basic gearbox
Riduttore base

M. flanges	Kit code	øF	A
71B5	K023.4.041	160	238.5
80/90B5	K023.4.042	200	240.5
100/112B5	K023.4.043	250	249.5
132B5	KC51.4.043	300	270.5
80B14	K085.4.046	120	240.5
90B14	K085.4.045	140	240.5
100/112B14	K085.4.047	160	249.5
132B14	KC51.4.041	200	270.5

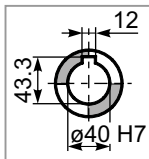
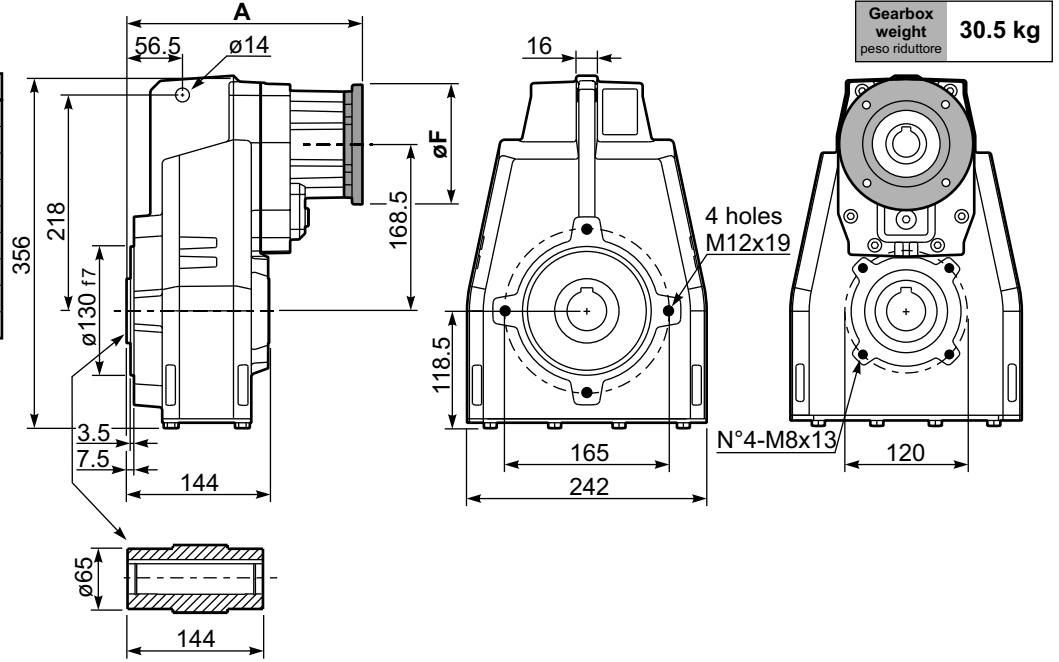

Standard
Hollow shaft

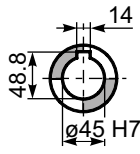

On request
A richiesta

PFC72...-F... Output flange
Flangia uscita

M. flanges	k1
71B5	271
80/90B5	273
100/112B5	282
132B5	300
80B14	273
90B14	273
100/112B14	282
132B14	300

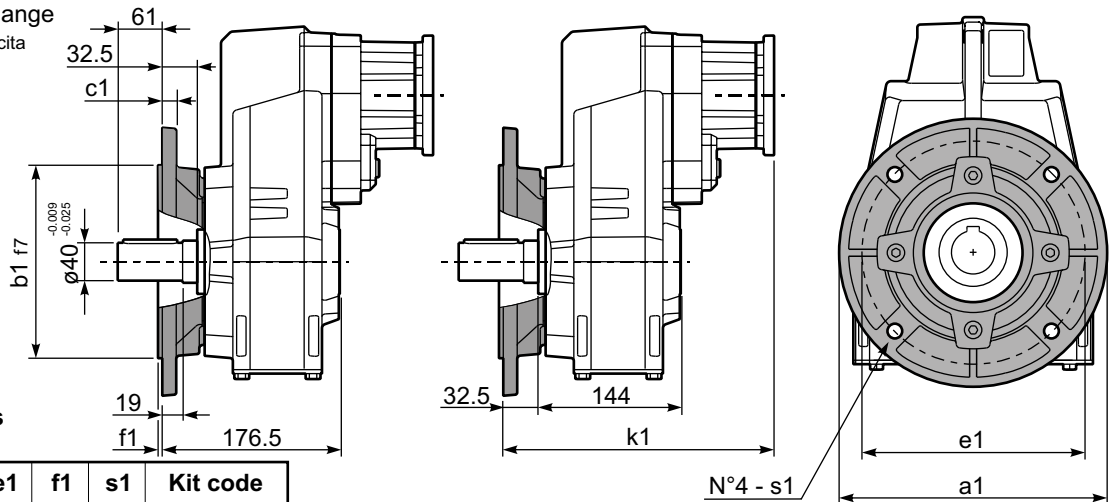

Available output flanges
Flange di uscita

a1 ø	b1	c1	e1	f1	s1	Kit code
250	180	13	215	3	14	KF70.9.011
300	230	16	265	4	14	KF70.9.012

RFC72C... Input Shaft
Albero in entrata

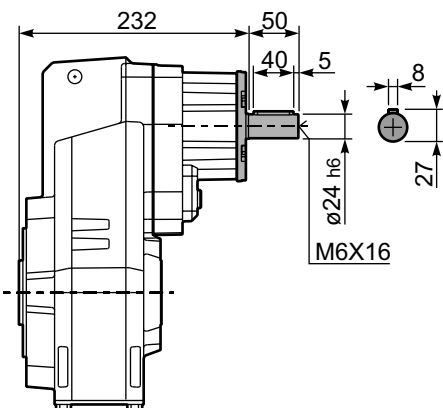

PFC72 A... Single output shaft
Albero uscita semplice

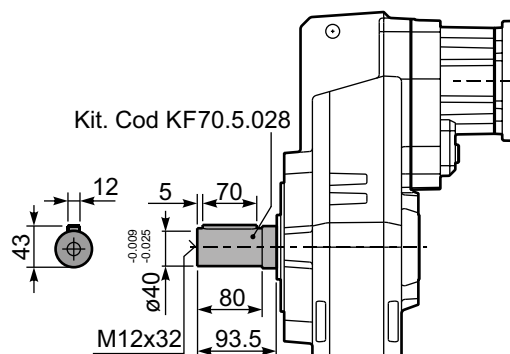

PFC72D... Shrink disk
Calettatore

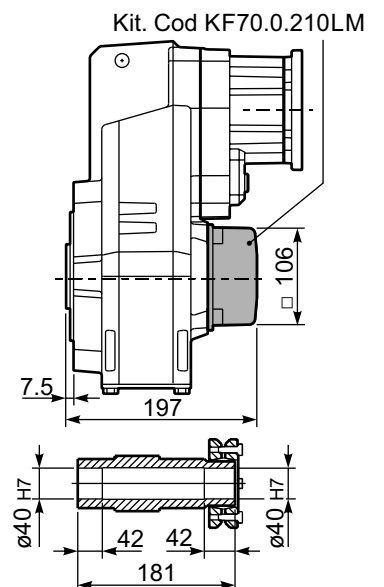



QUICK SELECTION / Selezione veloce

input speed (n_1) = 1400 min⁻¹

Output Speed n_2 [min ⁻¹]	Ratio i	Motor power P_{1M} [kW]	Output torque M_{2M} [Nm]	Service factor $f.s.$	Nominal power P_{1R} [kW]	Nominal torque M_{2R} [Nm]	Available B5 motor flanges				Available B14 motor flanges			Output Shaft 	Ratios code
							-B	-C	-D	-E	-Q	-R	-T		
							63	71	80	90	71	80	90		
18.5	75.50	1.5	725	1.1	1.7	825	B				C	C		191318	01
16.2	86.47	1.5	830	1.1	1.6	900	B				C	C		191316	02
14.0	100.22	1.5	962	0.9	1.4	900	B				C	C		171316	03
12.0	116.56	1.1	817	1.1	1.2	900	B				C	C		171314	04
10.2	136.82	1.1	959	0.9	1.0	900	B				C	C		151314	05
9.1	153.05	0.75	736	1.1	0.83	810	B				C	C		190816	06
8.6	163.31	0.75	785	1.1	0.86	900	B				C	C		131314	07
7.9	178.01	0.75	856	1.1	0.79	900	B				C	C		190814	08
7.3	191.67	0.75	922	1.0	0.73	900	B				C	C		101316	09
6.8	206.32	0.75	992	0.9	0.68	900	B				C	C		170814	10
6.3	222.92	0.55	791	1.1	0.63	900	B				C	C		101314	11
5.8	242.18	0.55	859	1.0	0.58	900	B				C	C		150814	12
5.6	250.15	0.55	888	1.0	0.56	900	B				C	C		91316	13
4.8	289.08	0.55	1026	0.9	0.49	900	B				C	C		130814	14
4.2	330.31	0.37	783	1.1	0.42	890	B				C	C		71316	15
3.5	394.59	0.37	936	1.0	0.36	900	B				C	C		100814	16
2.7	514.99	0.25	824	1.1	0.27	900	B				C	C		90814	17
2.1	680.03	0.18	832	1.1	0.21	900	B				C	C		70814	18

The dynamic efficiency is **0.94** for all ratios

- Motor Flanges Available** Flange Motore Disponibili
- B) Supplied with Reduction Bushing** Fornito con Bussola di Riduzione
- B) Available on Request without reduction bushing** Disponibile a Richiesta senza Bussola di Riduzione
- C) Motor Flange Holes Position** Posizione Fori Flangia Motore

EN Unit **FC73** is supplied without lubricant and equipped with a breather, level and drain plugs. User can add mineral oil keeping existing plugs. Should the user wish to fill it with synthetic oil, it is recommended to replace the existing plugs with a closed plug. See table 1 for lubrication and recommended quantity. In table 2 please see possible radial loads and axial loads on the gearbox.

3.55 LT	1.95 LT	1.95 LT	1.95 LT	3.75 LT	2.00 LT
SHELL Omala S2 GX 460			ENI Blasias 460		

For all details on lubrication and plugs check our website **tab. 1**
Per maggiori dettagli su lubrificazione e tappi olio vedi il nostro sito web

I Il riduttore tipo **FC73** è fornito privo di lubrificazione con tappi di sfiato, livello e scarico olio. L'utente può immettere olio minerale mantenendo i tappi esistenti. Se immetterà olio sintetico, dovrà sostituire i tappi esistenti con altri tipo chiuso. Tab.1 per oli e quantità consigliati. Tab.2 carichi radiali e assiali applicabili al riduttore.

D Das Getriebe der Baugröße **FC73** wird ohne Schmiermittel geliefert. Es ist jedoch mit Einfüllschraube, Überdruckventil und Ablassschraube ausgerüstet. Das benötigte mineralische Öl kann über die Einfüllschraube eingefüllt werden. Sollte synthetisches Öl bevorzugt werden, so ist sind das eingebaute Überdruckventil durch eine geschlossenen Schraube zu ersetzen. In Tabelle 1 ist die Schmiermenge und das empfohlene Schmiermittel angegeben. In Tabelle 2 sind die zulässigen Radial - und Axialbelastungen des Getriebes aufgeführt.

F Le réducteur de type **FC73** est fourni sans lubrification et avec un bouchon de remplissage, de niveau et d'évacuation de l'huile. L'utilisateur peut y verser de l'huile minérale en conservant les bouchons existants. S'il y versera de l'huile synthétique, il devra substituer les bouchons existants avec d'autres bouchons de type fermé. Voir tableau 1 concernant les huiles et les quantités conseillées. Voir tableau 2 concernant les charges radiales et axiales applicables au réducteur

E El reductor tamaño **FC73** se suministra sin lubricante, provisto de tapones de respiración, nivel y descarga de aceite. El usuario puede utilizar aceite mineral, manteniendo los tapones existentes. Si prefiere utilizar aceite sintético deberá sustituir los tapones existentes por tapones ciegos. La prerreducción se suministra con tapones ciegos, lubricado de por vida con aceite sintético. Ver tabla 1, para cantidades y aceites recomendados. En la tabla 2, se encuentran las cargas radiales y axiales admitidas por el reductor.

RADIAL AND AXIAL LOADS

Output shaft
Albero di uscita

$F_{eq} = F_R \cdot 174.5 \cdot X + 134.5$

n_2	FA	FR	n_2	FA	FR	n_2	FA	FR
300	740	3700	140	860	4300	70	1020	5100
250	800	4000	120	900	4500	40	1300	6500
200	830	4150	85	970	4850	15	1700	8500

On request reinforced bearings to increase loads.
A richiesta cuscinetti rinforzati per aumentare i carichi.

Input shaft
Albero in entrata

n_1	FA	FR
1400	400	2000
900	440	2200
500	440	2200

tab. 2

PFC73C... Basic gearbox
Riduttore base

Gearbox weight
peso riduttore **30.5 kg**

M. flanges	Kit code	øF	A
63B5	K063.4.041	140	250.5
71B5	K063.4.042	160	248.5
80/90B5	K063.4.043	200	250.5
71B14	K063.4.047	105	248.5
80B14	K063.4.046	120	250.5
90B14	K063.4.041	140	250.5

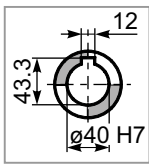
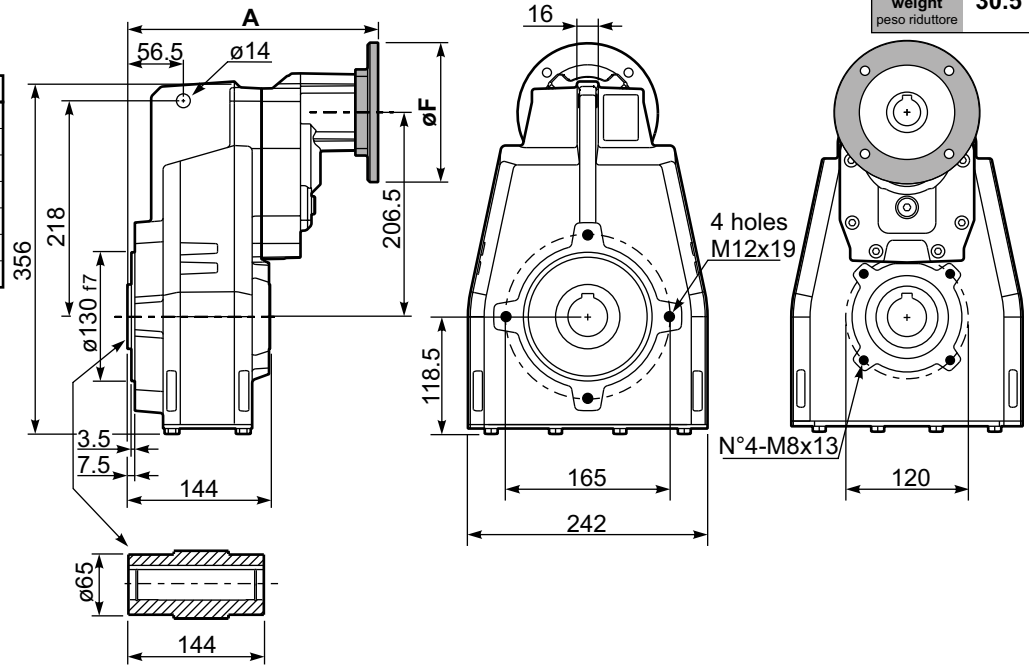

Standard
Hollow shaft

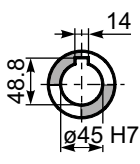

On request
A richiesta

PFC73...-F... Output flange
Flangia uscita

M. flanges	k1
63B5	283
71B5	281
80/90B5	283
71B14	281
80B14	283
90B14	283

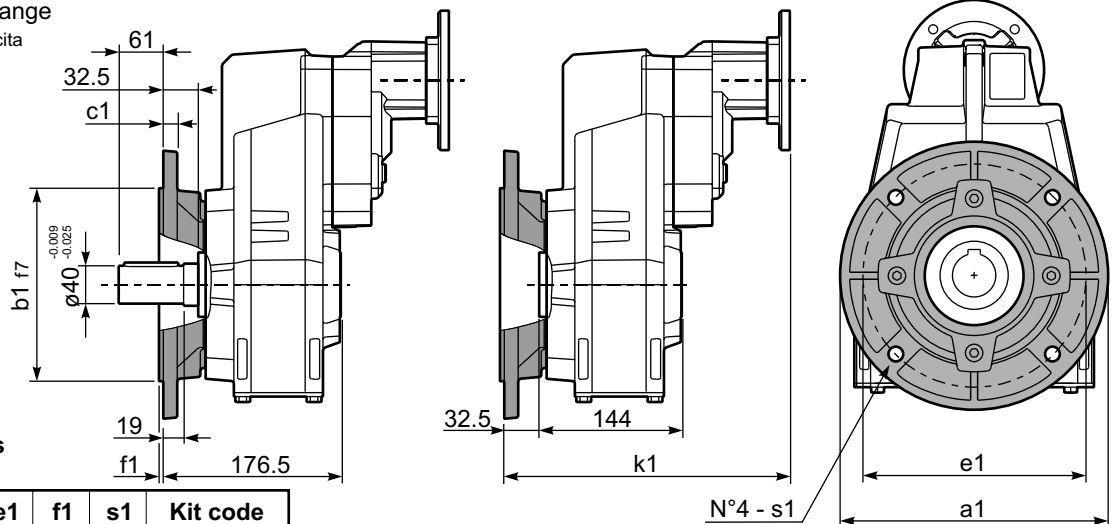

Available output flanges
Flange di uscita

a1 ø	b1	c1	e1	f1	s1	Kit code
250	180	13	215	3	14	KF70.9.011
300	230	16	265	4	14	KF70.9.012

RFC73C... Input Shaft
Albero in entrata

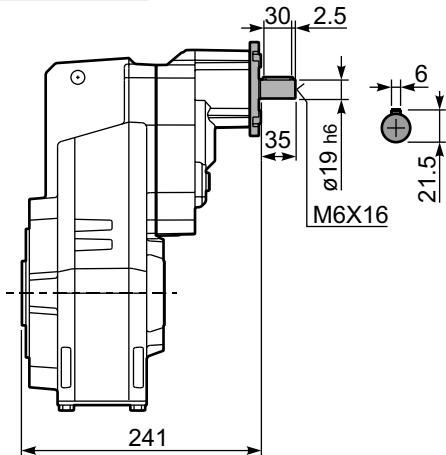

PFC73 A... Single output shaft
Albero uscita semplice

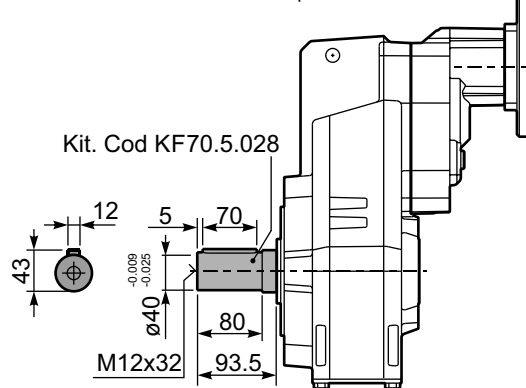

PFC73D... Shrink disk
Calettatore

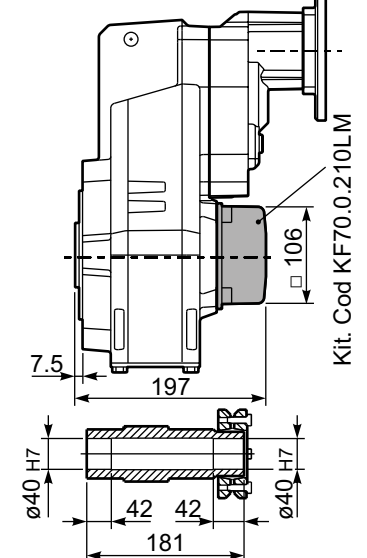



QUICK SELECTION / Selezione veloce input speed (n_1) = 1400 min⁻¹

Output Speed n_2 [min ⁻¹]	Ratio i	Motor power P_{1M} [kW]	Output torque M_{2M} [Nm]	Service factor f.s.	Nominal power P_{1R} [kW]	Nominal torque M_{2R} [Nm]	Available B5 motor flanges		B14 motor flanges				Output Shaft		
							-H	-I	-	-	-	-			Ratios code
							160	180	-	-	-	-			
528	2.65	22	374	1.7	36.7	650			not available				2361	standard	01
409	3.42	22	483	1.6	32.8	750			not available				1965	ø50	02
304	4.60	22	649	1.5	30.9	950			not available				1569		03
256	5.46	22	771	1.3	27.4	1000			not available				1371	ø55	04
211	6.64	22	937	1.3	26.5	1175			not available				1173	On request	05

The dynamic efficiency is **0.98** for all ratios

A) Motor Flanges Available Flange Motore Disponibili
 B) Supplied with Reduction Bushing Fornito con Bussola di Riduzione
 B) Available on Request without reduction bushing Disponibile a Richiesta senza Bussola di Riduzione
 C) Motor Flange Holes Position Posizione Fori Flangia Motore

EN Unit **FC81** is supplied without lubricant and equipped with a breather, level and drain plugs. User can add mineral oil keeping existing plugs. Should the user wish to fill it with synthetic oil, it is recommended to replace the existing plugs with a closed plug. See table 1 for lubrication and recommended quantity. In table 2 please see possible radial loads and axial loads on the gearbox.

H1	H4	H3	H2	H5	H6
5.50 LT	3.50 LT	3.50 LT	3.50 LT	6.20 LT	4.40 LT
SHELL Omala S2 GX 460			ENI Blasias 460		

For all details on lubrication and plugs check our website tab. 1
Per maggiori dettagli su lubrificazione e tappi olio vedi il nostro sito web

I Il riduttore tipo **FC81** è fornito privo di lubrificazione con tappi di sfiato, livello e scarico olio. L'utente può immettere olio minerale mantenendo i tappi esistenti. Se immetterà olio sintetico, dovrà sostituire i tappi esistenti con altri tipo chiuso. Tab.1 per oli e quantità consigliati. Tab.2 carichi radiali e assiali applicabili al riduttore.

D Das Getriebe der Baugröße **FC81** wird ohne Schmiermittel geliefert. Es ist jedoch mit Einfüllschraube, Überdruckventil und Ablassschraube ausgerüstet. Das benötigte mineralische Öl kann über die Einfüllschraube eingefüllt werden. Sollte synthetisches Öl bevorzugt werden, so ist sind das eingebaute Überdruckventil durch eine geschlossenen Schraube zu ersetzen. In Tabelle 1 ist die Schmiermenge und das empfohlene Schmiermittel angegeben. In Tabelle 2 sind die zulässigen Radial - und Axialbelastungen des Getriebes aufgeführt.

F Le réducteur de type **FC81** est fourni sans lubrification et avec un bouchon de remplissage, de niveau et d'évacuation de l'huile. L'utilisateur peut y verser de l'huile minérale en conservant les bouchons existants. S'il y versera de l'huile synthétique, il devra substituer les bouchons existants avec d'autres bouchons de type fermé. Voir tableau 1 concernant les huiles et les quantités conseillées. Voir tableau 2 concernant les charges radiales et axiales applicables au réducteur

E El reductor tamaño **FC81** se suministra sin lubricante, provisto de tapones de respiración, nivel y descarga de aceite. El usuario puede utilizar aceite mineral, manteniendo los tapones existentes. Si prefiere utilizar aceite sintético deberá sustituir los tapones existentes por tapones ciegos. La prerreducción se suministra con tapones ciegos, lubricado de por vida con aceite sintético. Ver tabla 1, para cantidades y aceites recomendados. En la tabla 2, se encuentran las cargas radiales y axiales admitidas por el reductor.

RADIAL AND AXIAL LOADS											
Output shaft Albero di uscita			$F_{eq} = FR \cdot \frac{227.5}{X+177.5}$								
F_R (N)	F_A (N)	F_R (N)	F_R (N)	F_R (N)	F_R (N)	F_R (N)	F_R (N)	F_R (N)	F_R (N)		
n_2	F_A	F_R	n_2	F_A	F_R	n_2	F_A	F_R	n_2	F_A	F_R
300	920	4600	140	1120	5600	70	1400	7000			
250	1000	5000	120	1140	5700	40	1800	9000			
200	1060	5300	85	1300	6500	15	2400	12000			

On request reinforced bearings to increase loads.
A richiesta cuscinetti rinforzati per aumentare i carichi.

tab. 2



QUICK SELECTION / Selezione veloce

input speed (n_1) = 1400 min⁻¹

Output Speed n_2 [min ⁻¹]	Ratio i	Motor power P_{1M} [kW]	Output torque M_{2M} [Nm]	Service factor f.s.	Nominal power P_{1R} [kW]	Nominal torque M_{2R} [Nm]	B5 motor flanges				B14 motor flanges		Output Shaft 	Ratios code
							-F	-G	-H	-I	-U	-V		
							100 112	132	160	180	100 112	132		
234	5.98	22	827	1.2	25.5	1000						3015	01	
197	7.10	22	982	1.2	25.3	1175						3013	02	
162	8.63	22	1193	1.1	23.9	1350						3011	03	
124	11.27	18.5	1310	1.1	20.3	1500						2015	04	
105	13.38	18.5	1555	1.1	19.4	1700						2013	05	
92	15.24	18.5	1771	1.1	19.0	1900						1615	06	
86	16.26	18.5	1889	1.1	19.7	2100						2011	07	
77	18.09	18.5	2102	1.0	17.7	2100						1613	08	
71	19.82	15	1865	1.1	15.9	2060						1315	09	
64	21.98	15	2069	1.0	14.6	2100						1611	10	
60	23.53	15	2214	0.9	13.6	2100						1313	11	
58	24.25	11	1677	1.2	12.2	1940						1115	12	
48.6	28.80	11	1991	1.1	11.1	2100						1113	13	
40.0	34.99	9	2063	1.0	9.2	2100						1111	14	
33.6	41.64	7.5	1976	1.0	7.2	1960						813	15	
27.7	50.60	5.5	1774	1.2	6.3	2100						811	16	

The dynamic efficiency is **0.96** for all ratios

Motor Flanges Available
Flange Motore Disponibili

B) Supplied with Reduction Bushing
Fornito con Bussola di Riduzione

B) Available on Request without reduction bushing
Disponibile a Richiesta senza Bussola di Riduzione

C) Motor Flange Holes Position
Posizione Fori Flangia Motore

EN Unit **FC82** is supplied without lubricant and equipped with a breather, level and drain plugs. User can add mineral oil keeping existing plugs. Should the user wish to fill it with synthetic oil, it is recommended to replace the existing plugs with a closed plug.
See table 1 for lubrication and recommended quantity. In table 2 please see possible radial loads and axial loads on the gearbox.

I Il riduttore tipo **FC82** è fornito privo di lubrificazione con tappi di sfiato, livello e scarico olio. L'utente può immettere olio minerale mantenendo i tappi esistenti. Se immetterà olio sintetico, dovrà sostituire i tappi esistenti con altri tipo chiuso.
Tab.1 per oli e quantità consigliati.
Tab.2 carichi radiali e assiali applicabili al riduttore.

D Das Getriebe der Baugröße **FC82** wird ohne Schmiermittel geliefert. Es ist jedoch mit Einfüllschraube, Überdruckventil und Ablassschraube ausgerüstet. Das benötigte mineralische Öl kann über die Einfüllschraube eingefüllt werden. Sollte synthetisches Öl bevorzugt werden, so ist sind das eingebaute Überdruckventil durch eine geschlossenen Schraube zu ersetzen.
In Tabelle 1 ist die Schmiermenge und das empfohlene Schmiermittel angegeben
In Tabelle 2 sind die zulässigen Radial - und Axialbelastungen des Getriebes aufgeführt.

F Le réducteur de type **FC82** est fourni sans lubrification et avec un bouchon de remplissage, de niveau et d'évacuation de l'huile. L'utilisateur peut y verser de l'huile minérale en conservant les bouchons existants. S'il y versera de l'huile synthétique, il devra substituer les bouchons existants avec d'autres bouchons de type fermé.
Voir tableau 1 concernant les huiles et les quantités conseillées.
Voir tableau 2 concernant les charges radiales et axiales applicables au réducteur

E El reductor tamaño **FC82** se suministra sin lubricante, provisto de tapones de respiración, nivel y descarga de aceite. El usuario puede utilizar aceite mineral, manteniendo los tapones existentes. Si prefiere utilizar aceite sintético deberá sustituir los tapones existentes por tapones ciegos. La prerreducción se suministra con tapones ciegos, lubricado de por vida con aceite sintético. Ver tabla 1, para cantidades y aceites recomendados. En la tabla 2, se encuentran las cargas radiales y axiales admitidas por el reductor.

5.70 LT	3.60 LT	3.60 LT	3.60 LT	6.60 LT	4.50 LT
SHELL Omala S2 GX 460			ENI Blasias 460		

For all details on lubrication and plugs check our website **tab. 1**
Per maggiori dettagli su lubrificazione e tappi olio vedi il nostro sito web

RADIAL AND AXIAL LOADS

Output shaft
Albero di uscita

$F_{eq} = F_R \cdot \frac{227.5}{X+177.5}$

n_2	FA	FR	n_2	FA	FR	n_2	FA	FR
300	920	4600	140	1120	5600	70	1400	7000
250	1000	5000	120	1140	5700	40	1800	9000
200	1060	5300	85	1300	6500	15	2400	12000

On request reinforced bearings to increase loads.
A richiesta cuscinetti rinforzati per aumentare i carichi.

Input shaft
Albero in entrata

n_1	FA	FR
1400	700	3500
900	840	4200
500	900	4500

tab. 2

PFC82C... Basic gearbox
Riduttore base

Gearbox weight **82.5 kg**
peso riduttore

M. flanges	Kit code	øF	A
100/112B5	K023.4.043	250	299
132B5	KC51.4.043C	300	320.5
160/180B5	KC86.4.0.43	350	352.5
100/112B14	K085.4.047	160	299
132B14	KC51.4.041C	200	320.5

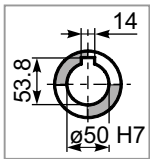
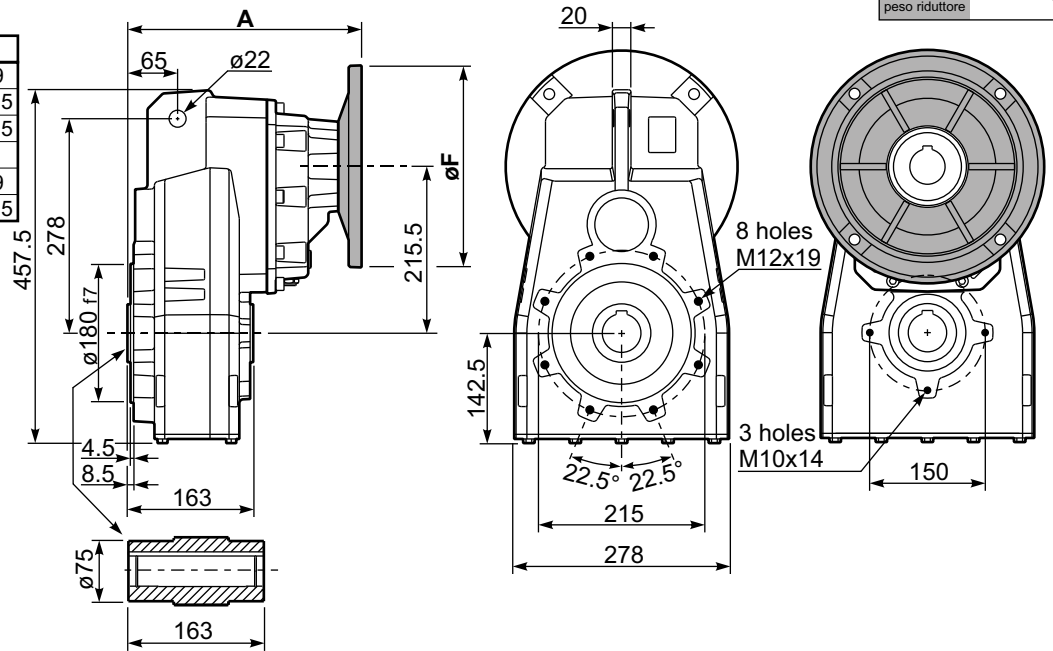

Standard
Hollow shaft

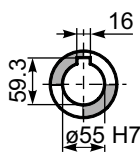

On request
A richiesta

PFC82...-F... Output flange
Flangia uscita

M. flanges	k1
100/112B5	345.5
132B5	367
160/180B5	399
100/112B14	345.5
132B14	367

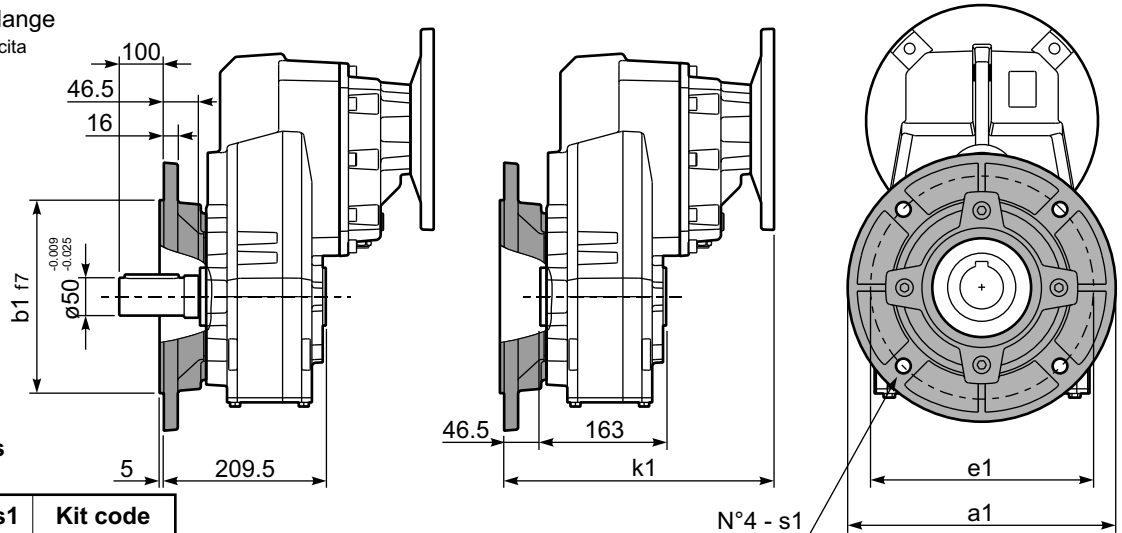

Available output flanges
Flange di uscita

a1 ø	b1	e1	s1	Kit code
300	230	265	14	KF80.9.011
350	250	300	18	KF80.9.012

RFC82C... Input Shaft
Albero in entrata

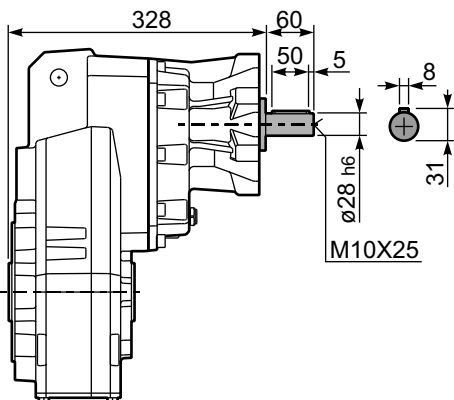

PFC82 A... Single output shaft
Albero uscita semplice

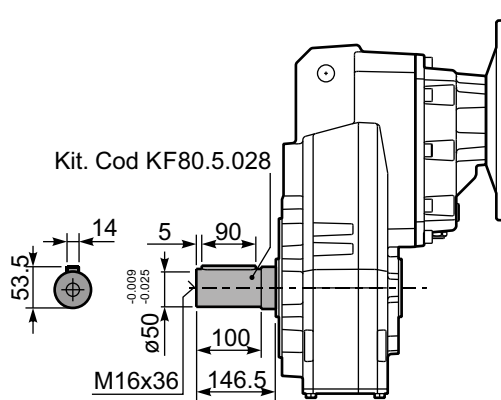

PFC82 D... Shrink disk
Calettatore

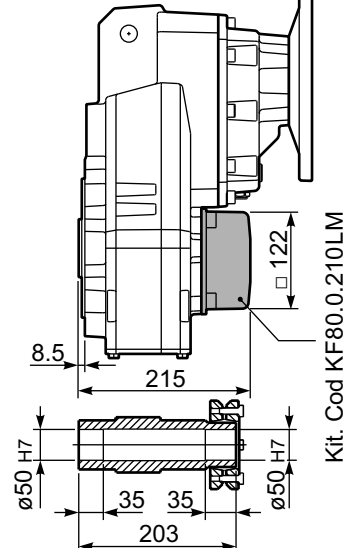



QUICK SELECTION / Selezione veloce

input speed (n_1) = 1400 min⁻¹

Output Speed n_2 [min ⁻¹]	Ratio i	Motor power P_{1M} [kW]	Output torque M_{2M} [Nm]	Service factor $f.s.$	Nominal power P_{1R} [kW]	Nominal torque M_{2R} [Nm]	Available B5 motor flanges					Available B14 motor flanges				Output Shaft 	Ratios code
							-C	-D	-E	-F	-G	-R	-T	-U	-V		
							71	80	90	100 112	132	80	90	100 112	132		
28.8	48.55	7.5	2257	0.9	6.7	2100	B									201315	01
24.3	57.64	5.5	1980	1.1	5.7	2100	B									201313	02
21.3	65.64	5.5	2255	0.9	5.0	2100	B									161315	03
20.0	70.04	4	1760	1.2	4.7	2100	B									201311	04
18.0	77.93	4	1958	1.1	4.2	2100	B									161313	05
16.4	85.36	4	2145	1.0	3.8	2100	B									131315	06
14.8	94.70	4	2380	0.9	3.5	2100	B									161311	07
13.8	101.35	3	1917	1.1	3.2	2100	B									131313	08
11.4	123.15	3	2330	0.9	2.7	2100	B									131311	09
9.3	150.73	2.2	2100	1.0	2.2	2100	B									111311	10
7.8	179.39	1.5	1722	1.2	1.8	2100	B									81313	11
6.4	217.98	1.5	2093	1.0	1.5	2100	B									81311	12
5.7	247.03	1.1	1732	1.1	1.2	1950	B									61313	13
4.7	300.17	1.1	2105	1.0	1.1	2100	B									61311	14

The dynamic efficiency is **0.94** for all ratios

- Motor Flanges Available Flange Motore Disponibili
- B) Supplied with Reduction Bushing Fornito con Bussola di Riduzione
- B) Available on Request without reduction bushing Disponibile a Richiesta senza Bussola di Riduzione
- C) Motor Flange Holes Position Posizione Fori Flangia Motore

EN Unit FC83 is supplied without lubricant and equipped with a breather, level and drain plugs. User can add mineral oil keeping existing plugs. Should the user wish to fill it with synthetic oil, it is recommended to replace the existing plugs with a closed plug. See table 1 for lubrication and recommended quantity. In table 2 please see possible radial loads and axial loads on the gearbox.

H1	H4	H3	H2	H5	H6
5.80 LT	3.90 LT	3.90 LT	3.90 LT	6.80 LT	4.90 LT
SHELL Omala S2 GX 460			ENI Blasias 460		

For all details on lubrication and plugs check our website [tab. 1](#)
Per maggiori dettagli su lubrificazione e tappi olio vedi il nostro sito web

I Il riduttore tipo FC83 è fornito privo di lubrificazione con tappi di sfiato, livello e scarico olio. L'utente può immettere olio minerale mantenendo i tappi esistenti. Se immetterà olio sintetico, dovrà sostituire i tappi esistenti con altri tipo chiuso. Tab.1 per oli e quantità consigliati. Tab.2 carichi radiali e assiali applicabili al riduttore.

D Das Getriebe der Baugröße FC83 wird ohne Schmiermittel geliefert. Es ist jedoch mit Einfüllschraube, Überdruckventil und Ablassschraube ausgerüstet. Das benötigte mineralische Öl kann über die Einfüllschraube eingefüllt werden. Sollte synthetisches Öl bevorzugt werden, so ist sind das eingebaute Überdruckventil durch eine geschlossenen Schraube zu ersetzen. In Tabelle 1 ist die Schmiermenge und das empfohlene Schmiermittel angegeben. In Tabelle 2 sind die zulässigen Radial - und Axialbelastungen des Getriebes aufgeführt.

F Le réducteur de type FC83 est fourni sans lubrification et avec un bouchon de remplissage, de niveau et d'évacuation de l'huile. L'utilisateur peut y verser de l'huile minérale en conservant les bouchons existants. S'il y versera de l'huile synthétique, il devra substituer les bouchons existants avec d'autres bouchons de type fermé. Voir tableau 1 concernant les huiles et les quantités conseillées. Voir tableau 2 concernant les charges radiales et axiales applicables au réducteur

E El reductor tamaño FC83 se suministra sin lubricante, provisto de tapones de respiración, nivel y descarga de aceite. El usuario puede utilizar aceite mineral, manteniendo los tapones existentes. Si prefiere utilizar aceite sintético deberá sustituir los tapones existentes por tapones ciegos. La prerreducción se suministra con tapones ciegos, lubricado de por vida con aceite sintético. Ver tabla 1, para cantidades y aceites recomendados. En la tabla 2, se encuentran las cargas radiales y axiales admitidas por el reductor.

RADIAL AND AXIAL LOADS

Output shaft
Albero di uscita

$F_{eq} = F_R \cdot \frac{227.5}{X+177.5}$

n_2	FA	FR	n_2	FA	FR	n_2	FA	FR
300	920	4600	140	1120	5600	70	1400	7000
250	1000	5000	120	1140	5700	40	1800	9000
200	1060	5300	85	1300	6500	15	2400	12000

On request reinforced bearings to increase loads.
A richiesta cuscinetti rinforzati per aumentare i carichi.

Input shaft
Albero in entrata

n_1	FA	FR
1400	450	2250
900	500	2500
500	600	3000

tab. 2

PFC83C... Basic gearbox
Riduttore base

Gearbox weight **68.5 kg**
peso riduttore

M. flanges	Kit code	øF	A
71B5	K023.4.041	160	292.5
80/90B5	K023.4.042	200	294.5
100/112B5	K023.4.043	250	303.5
132B5	KC51.4.043	300	324.5
80B14	K085.4.046	120	294.5
90B14	K085.4.045	140	294.5
100/112B14	K085.4.047	160	303.5
132B14	KC51.4.041	200	324.5

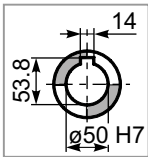
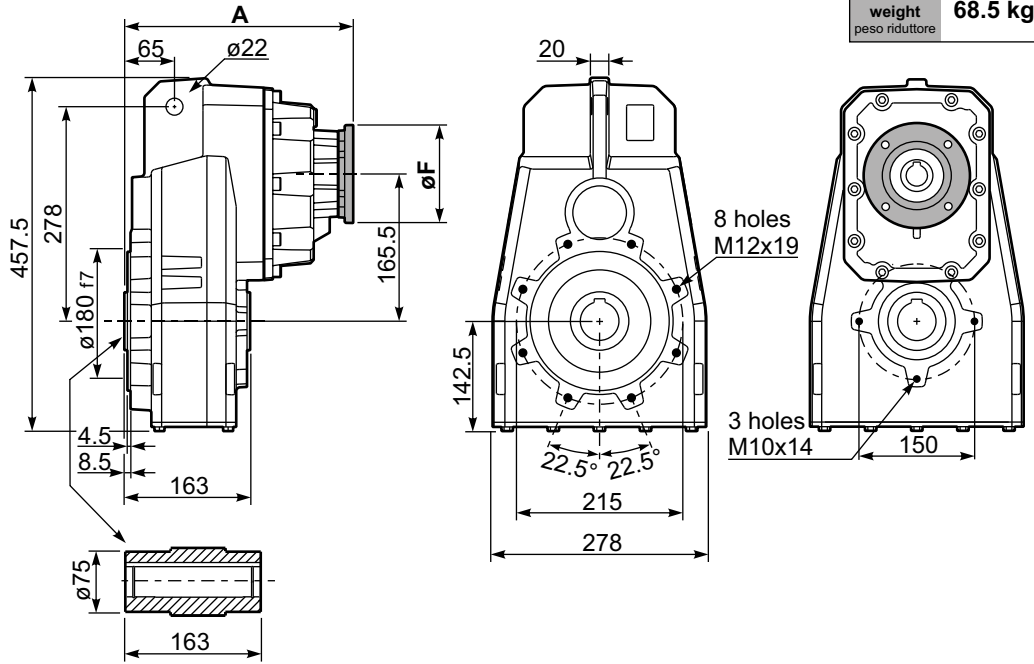

Standard
Hollow shaft

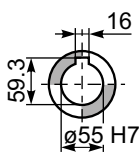

On request
A richiesta

PFC83...-F... Output flange
Flangia uscita

M. flanges	k1
71B5	339
80/90B5	341
100/112B5	350
132B5	368
80B14	341
90B14	341
100/112B14	350
132B14	368

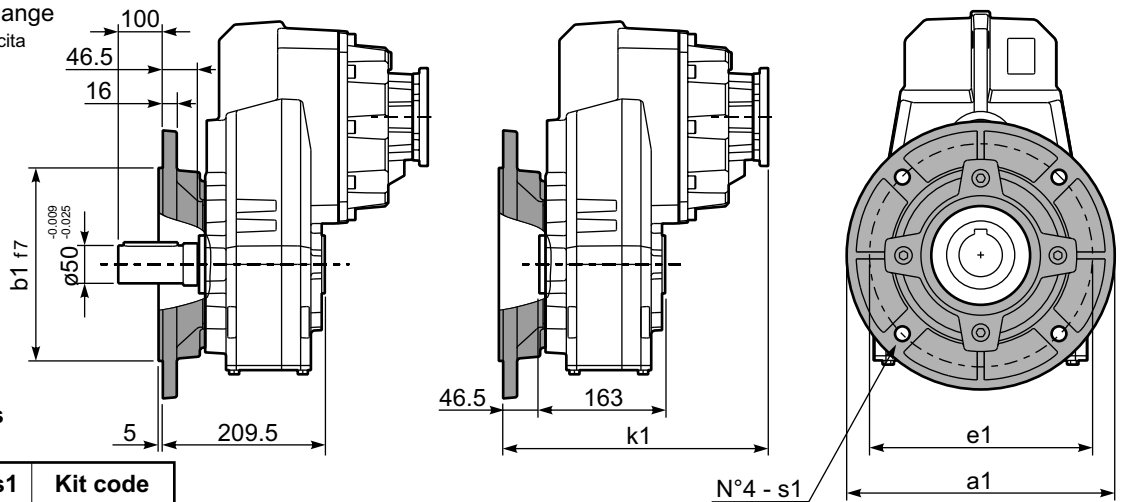

Available output flanges
Flange di uscita

a1 ø	b1	e1	s1	Kit code
300	230	265	14	KF80.9.011
350	250	300	18	KF80.9.012

RFC83C... Input Shaft
Albero in entrata

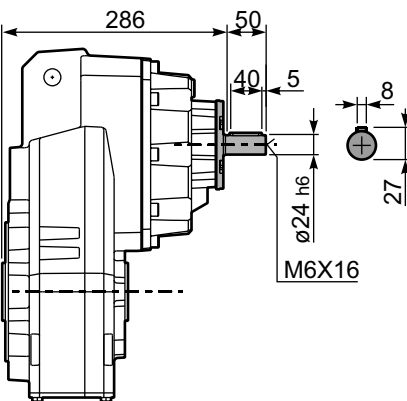

PFC83 A... Single output shaft
Albero uscita semplice

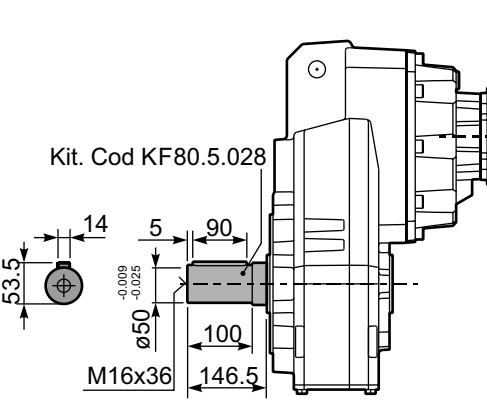

PFC83D... Shrink disk
Calettatore
Kit. Cod KF80.0.210LM

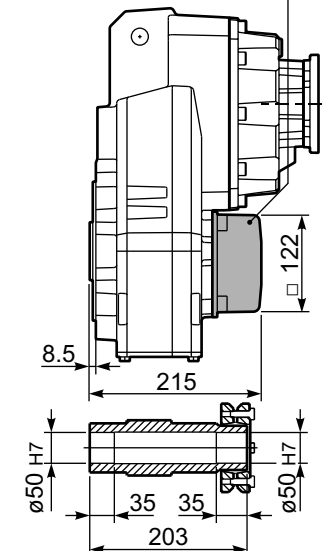

Cast iron parallel shaft gearboxes

A modular and compact product

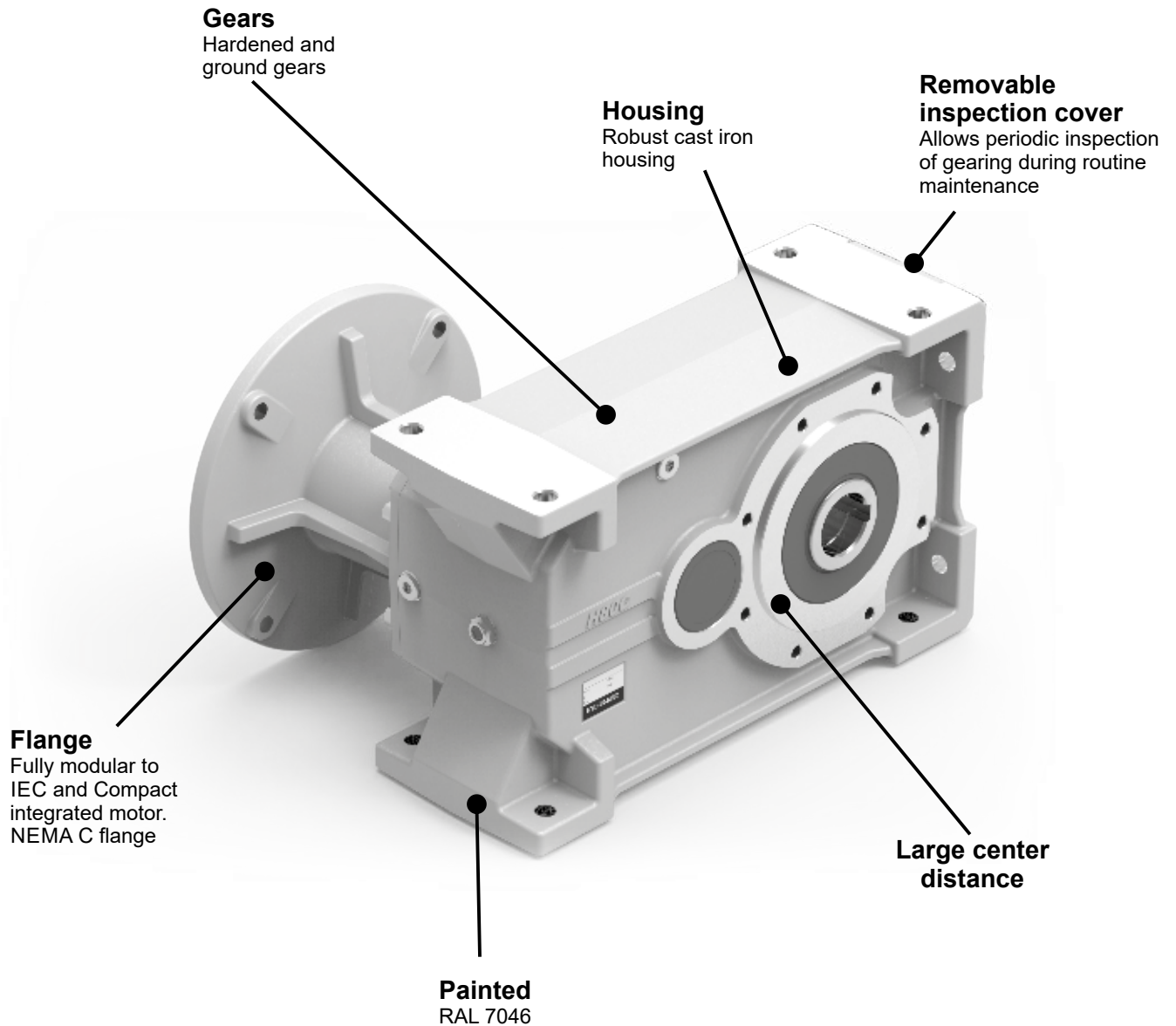

Single-piece Cast Iron housing

with high tensile strength. Precision machined for alignment of bearings and gearing

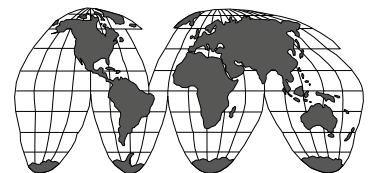
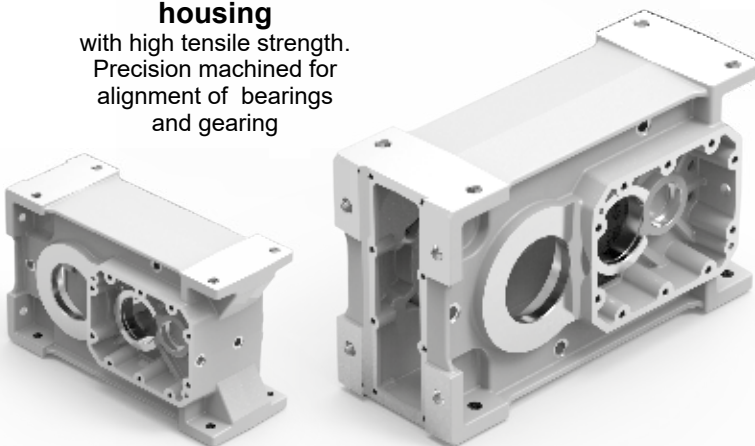

World wide sales network.

Specific type datasheet on page...

On page / A pagina / Auf Seite / À la page / En la página

1 Stage

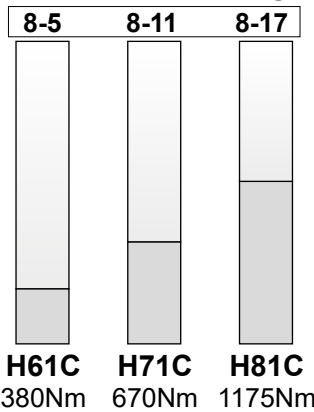
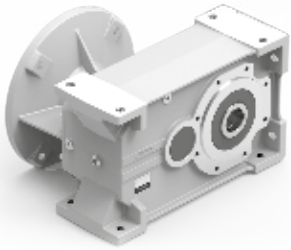

Types / Tipi /
Tipen / Types /
Tipos

On page / A pagina / Auf Seite / À la page / En la página

2 and 3 Stage

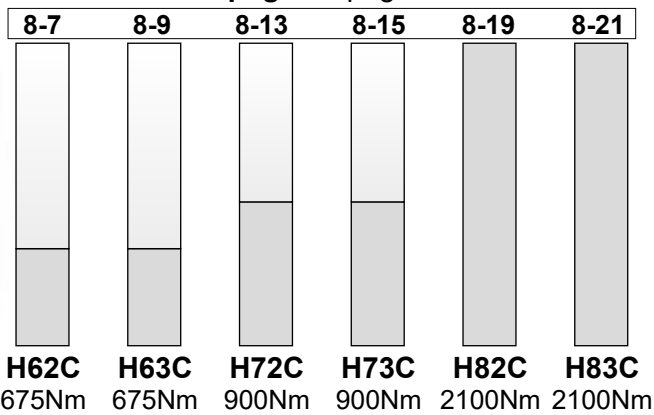
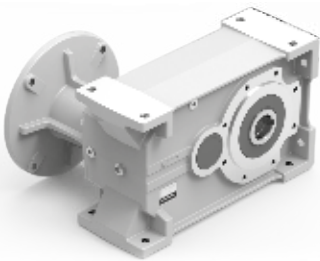

Types / Tipi /
Tipen / Types /
Tipos

On page / A pagina / Auf Seite / À la page / En la página

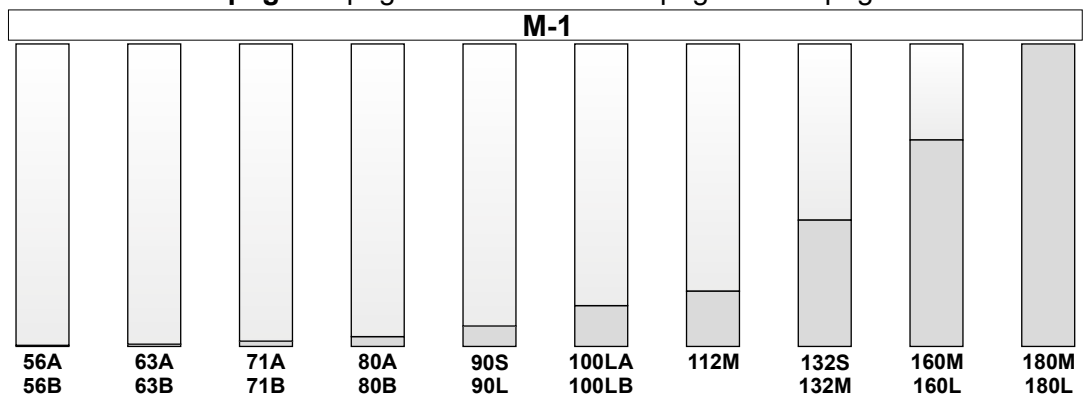
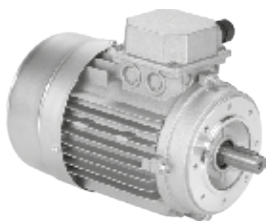



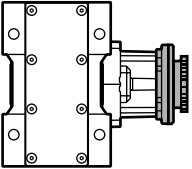
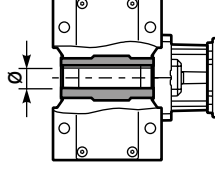
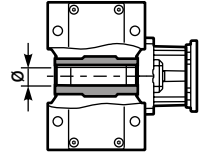
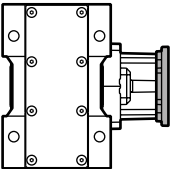
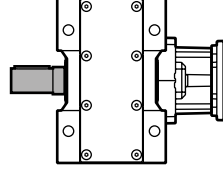
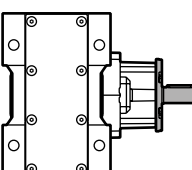
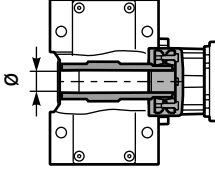
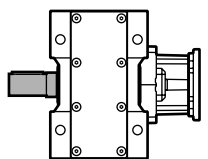
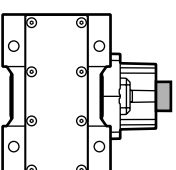
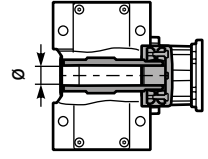





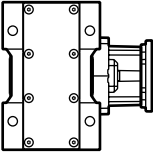
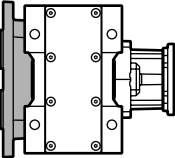

Types / Tipi /
Tipen / Types /
Tipos

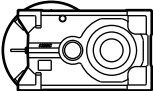
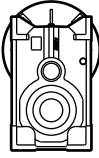
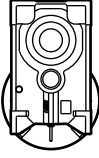
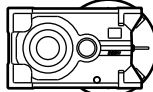
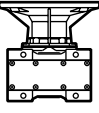
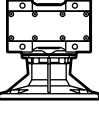
Type - Tipo - Typ Type - Tipo	Size - Grandezza - Grösse Taille - Tamaño	Mounting - Montaggio Montage - Fixation Tipo de montaje	Rapporto - Ratio Untersetzung Reduction - Relacion	Output shaft Albero uscita Abtriebswelle Arbre de sortie Eje en salida
M	H62C	C	12.39	-E
<p>Parallel shaft helical Riduttori ad assi paralleli</p> 	<p>1 Stage Riduzione Stufe Trains Etapas</p> <p>2 Stages Riduzioni Stufen Trains Etapas</p> <p>3 Stages Riduzioni Stufen Trains Etapas</p> <p>Cast Iron/Ghisa/Grauguss/Fonle/Fundicion</p>		<p>See technical data table</p> <p>Vedi tabelle dati tecnici.</p> <p>Technisches Datenblatt beachten</p> <p>Voir Tableau données techniques</p> <p>Ver tabla datos técnicos</p>	
<p>With IEC motor M</p>	<p>H61C H71C H81C</p>	<p>Hollow output shaft C</p>	<p>→ STANDARD ⇒ Only on request for Q.ty A richiesta per quantità</p>	<p>⇒ Only on request for Q.ty A richiesta per quantità</p>
 <p>With motor flange P</p>	<p>H62C H72C H82C</p> <p>H63C H73C H83C</p>	 <p>Single output shaft A</p>		<p>H61C H62C H63C -E ⇒ $\varnothing 35$ -F ⇒ $\varnothing 40$</p> <p>H71C H72C H73C -F ⇒ $\varnothing 40$ -G ⇒ $\varnothing 45$</p> <p>H81C H82C H83C -H ⇒ $\varnothing 50$ -I ⇒ $\varnothing 55$</p>
 <p>With male input shaft R</p>		 <p>Shrink Disk D</p> <p>Only on request for Q.ty A richiesta per quantità</p>		 <p>Single output shaft</p> <p>-N H61/2/3C ⇒ $\varnothing 35$ -O H71/2/3C ⇒ $\varnothing 40$ -K H81/2/3C ⇒ $\varnothing 50$</p>
 <p>Modular base B</p> <p>Not available for: H61C, H71C, H81C, H82C</p>				 <p>Shrink disk</p> <p>-T H62/3C ⇒ $\varnothing 35$ -U H72/3C ⇒ $\varnothing 40$ -V H82/3C ⇒ $\varnothing 50$</p>

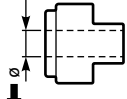
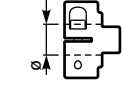
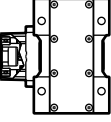

On request we can deliver our products according to the ATEX
 A richiesta possiamo fornire i nostri prodotti secondo le normative ATEX
 Auf Anfrage können wir unsere Produkte den Richtlinien ATEX entsprechend liefern
 Sur demande nos produits peuvent se conformer à la réglementation ATEX
 A pedido, se pueden enviar nuestros productos de acuerdo con las normas ATEX.

Type - Tipo - Typ Types - Tipo	Output flange Flangia uscita Ausgangsflansch Bride de sortie Brida en salida	Motor size - Grandezza motore Motor Größe Motor Grösse Grandeur moteur - Tamaño motor	Mounting position Posizione montaggio Einbaulage Position de montage Position de montaje	Input bore Foro entrata Eingangshohlwelle Trou d'entree Eje hueco de entrada	Terminal box position Posizione morsettieria Klemmkastenlage Position boîte à bornes Posición caja de bornes
<p>-N</p>  <p>-N Senza flangia Without flange</p>  <p>-F Whit output flange con flangia uscita</p>	<p>N</p> <p>Senza flangia Without flange</p> <p>H61C H62C H63C</p> <p>4 → ø250</p> <p>H71C H72C H73C</p> <p>4 → ø250 5 → ø300</p> <p>H81C H82C H83C</p> <p>5 → ø300 6 → ø350</p>	<p>-C</p> <p>Flange Flangia</p>  <p>B5</p> <p>-A=56 (ø120) -B=63 (ø140) -C=71 (ø160) -D=80 (ø200) -E=90 (ø200) -F=100 (ø250) -G=132 (ø300) -H=160 (ø350) -I=180 (ø350)</p> <p>B14</p> <p>-O=56 (ø80) -P=63 (ø90) -Q=71 (ø105) -R=80 (ø120) -T=90 (ø140) -U=100 (ø160) -V=132 (ø200)</p> <p>Brushless</p> <p>BB=50/70-M5 BC=60/75-M5 BD=70/90-M6 BE=80/100-M6 BF=95/115-M8 BG=110/145-M8 BH=130/165-M8</p> <p>Type R Tipo R</p>  <p>H63C H73C</p> <p>-2 → ø19</p> <p>H62C H72C H83C</p> <p>-3 → ø24</p> <p>H82C</p> <p>-4 → ø28</p> <p>Without flange Senza flangia</p>  <p>-M → With coupling</p> <p>H63C H73C</p> <p>-1 → ø14 (71B5) -2 → ø19 (80B5) -3 → ø24 (90B5)</p> <p>H62C H72C H83C</p> <p>-2 → ø19 (80B5) -3 → ø24 (90B5) -4 → ø28 (100B5)</p>	<p>B3</p>  <p>B3 STANDARD</p>  <p>B6</p>  <p>B7</p>  <p>B8</p>  <p>V5</p>  <p>V6</p>  <p>V8</p>	<p>ST</p> <p>standard bore foro standard</p> <p>COUPLING STANDARD (IEC)</p>  <p>-A = 9mm -B = 11mm -C = 14mm -D = 19mm -E = 24mm -F = 28mm</p> <p>BRUSHLESS *</p>  <p>-3 = 14mm -4 = 19mm -5 = 22mm -6 = 24mm</p> <p>-0</p> <p>Ready for input coupling Predisposto per giunto</p>  <p>* With reduction bushing where applicable Con bussola di riduzione dove prevista</p>	<p>With Type M specify terminal box position Con tipo M specificare posizione morsettieria</p>  <p>A</p>  <p>B STANDARD</p>  <p>C</p>  <p>D</p>

POTENZA RICHIESTA / REQUIRED POWER / ERFORDERLICHE LEISTUNG / PUISSANCE NECESSAIRE / POTENCIA NECESARIA

Lifting / sollevamento / hubantriebe / levage / elevación

$$P [KW] = \frac{M [Kg] \cdot g [9.81] \cdot v [m / s]}{1000}$$

Rotation / rotazione / drehung / rotation / rotação

$$P [KW] = \frac{M [Nm] \cdot n [rpm]}{9550}$$

Linear movement / traslazione / linearbewegung / translation / translación

$$P [KW] = \frac{F [N] \cdot v [m / s]}{1000}$$

TORQUE / COPPIA / DREHMOMENT / COUPLE / PAR

$$M [Nm] = \frac{9550 \cdot P[KW]}{n [rpm]}$$

$$M [lb in] = \frac{63030 \cdot P[HP]}{n [rpm]}$$

RADIAL LOADS / CARICHI RADIALI / RADIALE - UND AXIALLASTEN / CHARGES RADIALES / CARGA RADIAL Y AXIAL

- Radial load generated by external transmissions keyed onto input and/or output shafts.
- Forza radiale generata da organi di trasmissione calettati sugli alberi di ingresso e/o uscita.
- Belastungen der Antriebs- bzw. Abtriebswellen durch von aussen eingebrachte Radiallasten.
- Charge radiale générée par la transmissions calés sur les entrées et / ou des arbres de sortie
- Cargas radiales, generada por transmisiones externas, aplicadas sobre los ejes de entrada y/o salida

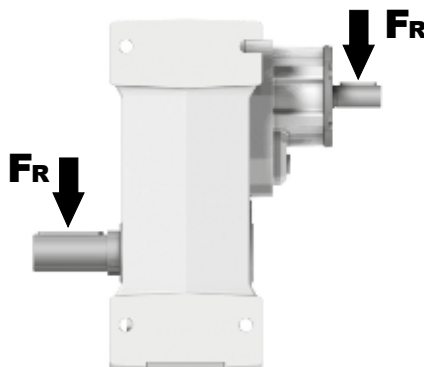

$$F_R [N] = \frac{M [Nm] \cdot 2000}{d [mm]} \cdot f_k$$

$$F_R [N] = \frac{M [lb in] \cdot 8.9}{d [in]} \cdot f_k$$

M	Momento torcente / Output torque / Abtriebsdrehmoment / Couple / Par torsion
d	Diametro primitivo / Diam. of driving element / Durchmesser der Abtriebseinheit / Diamètre primitif / Diámetro primitivo
f_k	Coefficiente di trasformazione / Factor / Faktor / Coefficient de transmission / Coeficiente de transmisión 1.15 Ingranaggi / Gearwheels / Zahnrad / Engrenage / Engranaje 1.25 Catena / Chain sprockets / Antriebskette / Chaîne / Cadena 1.75 Cinghia Trapezoidale / Narrow v-belt pulley / Keilriemen / Courroie trap. / Correa trapezoidal 2.50 Cinghia piatta / Flat-belt pulley / Flachzahnriem. / Courroie crantée / Correa plana

- If your application requires higher radial loads, contact our technical office. Higher load may be possible.
- Nel caso la vostra applicazione richieda carichi radiali superiori consultare il nostro ufficio tecnico, valori maggiori possono essere accettati.
- Wenn Ihre Anwendung höhere Radialbelastungen erfordert, so wenden Sie sich bitte an unser technischen Büro.
- Si votre application demande des charges radiales supérieures, s'adresser à notre bureau technique.
- En el caso en que una aplicación exija una carga radial superior a la especificada en el catálogo, consultar a nuestra oficinas técnica.

How to select a gearbox / Come selezionare un riduttore / Wie wählt man ein Getriebe
Comment sélectionner un réducteur / Cómo seleccionar un reductor

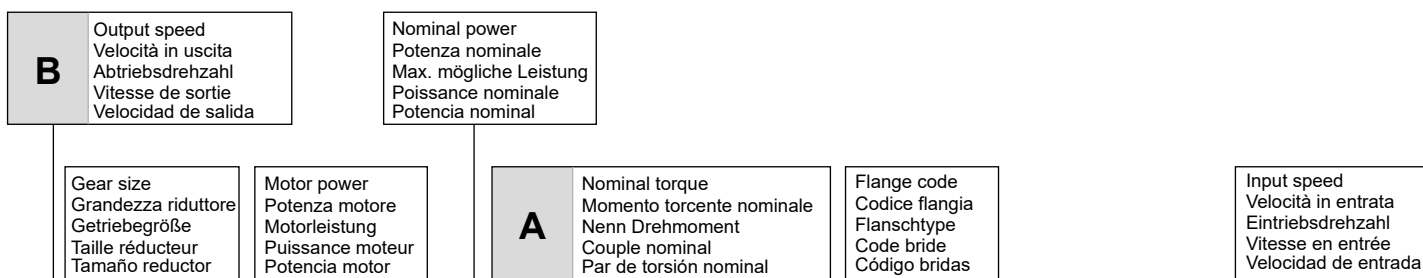

H62C Cube gear **675Nm** Rating - Cast Iron
PARALLEL SHAFT GEARBOXES

QUICK SELECTION / Selezione veloce input speed (n_1) = 1400 min⁻¹

Output Speed n_2 [min ⁻¹]	Ratio i	Motor power P_{1M} [kW]	Output torque M_{2M} [Nm]	Service factor f.s.	Nominal power P_{1R} [kW]	Nominal torque M_{2R} [Nm]	Available B5 motor flanges					Available B14 motor flanges				Output Shaft 	Ratios code 	
							-C	-D	-E	-F	-G	-R	-T	-U	-V			
213	6.57	7.5	312	1.2	8.8	380	B										3018	01
185	7.56	7.5	358	1.1	7.9	390	B										3016	02
159	8.82	7.5	419	1.0	7.1	410	B										3014	03
113	12.39	7.5	588	1.0	7.2	580	B										2018	04



fs

Type of load and starts per hour Tipo di carico e avviamenti per ora		Oper. hours per day Ore di funz. giorn.		
		3 h	10 h	24 h
Continuous or intermittent appl. with start / hour Applicazione cont. o interm. con n.ro operazioni/ora	Uniform / Uniforme	0.8	1	1.25
	Moderate / Moderato	1	1.25	1.5
	Heavy / Forte	1.25	1.5	1.75
Intermittent application with start / hour Applicazione intermittente con n.ro operazioni/ora	Uniform / Uniforme	1	1.25	1.5
	Moderate / Moderato	1.25	1.5	1.75
	Heavy / Forte	1.5	1.75	2.15

D Motor flange available
Flange disponibili
Erhältliche Motorflansche
Brides disponibles
Bridas disponibles

B) Mounting with reduction ring
Montaggio con boccola di riduzione
Reduzierhülsen
Montage avec douille de réduction
Montaje con casquillo de reducción

C) Motor flangeholes position/terminal box position
Posizione fori flangia/basetta motore
Bohrungsposition am Motorflansch/-socket
Position trous bride/barrette à bornes moteur
Posición agujeros brida / base motor

B) Available without reduction bushes
Disponibile anche senza boccola
Auch ohne Reduzierbuchse verfügbar
Disponible aussi sans douille de réduction
Disponible tambien sin casquillo

A	Select required torque (according to service factor)	Seleziona la coppia desiderata (comprensiva del fattore di servizio)	Max. Drehmoment in Bezug zum Betriebsfaktor	Sélectionner le couple souhaité (comprenant le facteur de service)	Seleccionar el par deseado (incluyendo el factor de servicio)
B	Select output speed	Seleziona la velocità in uscita	Ausgewählte Abtriebsdrehzahl	Sélectionner la vitesse de sortie	Seleccionar la velocidad de salida
C	On the same line of selected geared motor, you can find the gear ratio	Sulla riga corrispondente alla motorizzazione prescelta si può rilevare il rapporto di riduzione	Auf der gleichen Linie wie die ausgewählte Motorleistung steht auch die Getriebeuntersetzung	Sur la ligne correspondante à la motorisation pré-choisie on peut relever le rapport de réduction	En la línea correspondiente al motor preseleccionado es posible encontrar la relación de reducción
D	Select motor flange available (if requested)	Scegli la flangia disponibile (se richiesta)	Erhältliche Motorflansche (auf Anfrage)	Choisir la bride disponible (si elle est demandée)	Seleccionar la brida disponible (sobre pedido)

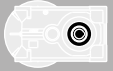

QUICK SELECTION / Selezione veloce							input speed (n ₁) = 1400 min ⁻¹								
Output Speed n ₂ [min ⁻¹]	Ratio i	Motor power P _{1M} [kW]	Output torque M _{2M} [Nm]	Service factor f.s.	Nominal power P _{1R} [kW]	Nominal torque M _{2R} [Nm]	Available B5 motor flanges		B14 motor flanges				Output Shaft		
							-G	132	-	-	-	-	-	-	Ø
507	2.76	9	166	1.6	14.4	265			not available				2980	standard	01
395	3.54	9	213	1.3	11.6	275							2485	ø35	02
277	5.06	9	304	1.0	8.6	290							1891		03
241	5.81	7.5	281	1.2	8.5	330							1693	ø40	04
206	6.79	7.5	329	1.2	8.4	380							1495	On request	05

The dynamic efficiency is **0.98** for all ratios

Motor Flanges Available Flange Motore Disponibili
 B) Supplied with Reduction Bushing Fornito con Bussola di Riduzione
 B) Available on Request without reduction bushing Disponibile a Richiesta senza Bussola di Riduzione
 C) Motor Flange Holes Position Posizione Fori Flangia Motore

EN Unit **H61C** is supplied with synthetic oil for lifetime lubrication, no maintenance is necessary. See table 1 for lubrication and recommended quantity. In table 2 please see possible radial loads and axial loads on the gearbox.

I Il riduttore **H61C** viene fornito completo di olio sintetico per la lubrificazione permanente e non necessita di alcuna manutenzione. Vedi tab.1 per oli e quantità consigliati. In tab.2 sono presenti i carichi radiali e assiali applicabili al riduttore.

D Das Getriebe **H61C** ist mit synthetischem Öl gefüllt und ist lebensdauergeschmiert. In Tabelle 1 ist die Schmiermenge und das empfohlene Schmiermittel angegeben. In Tabelle 2 sind die zulässigen Radial - und Axialbelastungen des Getriebes aufgeführt.

F Le réducteur **H61C** est fourni complet avec de l'huile synthétique pour la lubrification permanente et ne nécessite aucun entretien. Voir tableau 1 concernant les huiles et les quantités conseillées. Les charges radiales et axiales applicables au réducteur sont précisées dans le tableau 2.

E El reductor tamaño **H61C** se suministra, lubricado de por vida con aceite sintético y no requieren mantenimiento alguna. Ver tabla 1, para cantidades y aceites recomendados. En la tabla 2, se encuentran las cargas radiales y axiales admitidas por el reductor.

Standard supplied	For these mounting position specify in the order or add oil							
	Per queste posizioni specificare in fase d'ordine o aggiungere olio							
B3	B6	B7	B8	V5	V6	V8	V8	V8
2.25 LT	3.20 LT	3.00 LT	2.25 LT	4.35 LT	2.35 LT	Ask	Ask	Ask
SHELL Omala S4 WE 320				ENI Telium VSF 320				

For all details on lubrication and plugs check our website **tab. 1**
Per maggiori dettagli su lubrificazione e tappi olio vedi il nostro sito web

RADIAL AND AXIAL LOADS								
Output shaft Albero di uscita			$F_{eq} = F_R \cdot \frac{149.5}{X+119.5}$					
n ₂	FA	FR	n ₂	FA	FR	n ₂	FA	FR
300	600	3000	140	720	3600	70	940	4700
250	640	3200	120	740	3700	40	1220	6100
200	690	3460	85	860	4300	15	1300	6500
On request reinforced bearings to increase loads. A richiesta cuscinetti rinforzati per aumentare i carichi.								

tab. 2

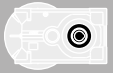

▪ **QUICK SELECTION** / Selezione veloce

input speed (n_1) = 1400 min⁻¹

Output Speed n_2 [min ⁻¹]	Ratio i	Motor power P_{1M} [kW]	Output torque M_{2M} [Nm]	Service factor $f.s.$	Nominal power P_{1R} [kW]	Nominal torque M_{2R} [Nm]	Available B5 motor flanges					Available B14 motor flanges				Output Shaft 	Ratios code	
							-C	-D	-E	-F	-G	-R	-T	-U	-V			
							71	80	90	100 112	132	80	90	100 112	132			
213	6.57	7.5	312	1.2	8.8	380	B										3018	01
185	7.56	7.5	358	1.1	7.9	390	B										3016	02
159	8.82	7.5	419	1.0	7.1	410	B										3014	03
113	12.39	7.5	588	1.0	7.2	580	B										2018	04
98	14.24	5.5	499	1.2	6.4	600	B										2016	05
84	16.75	5.5	587	1.1	6.1	665	B										1618	06
73	19.25	5.5	675	1.0	5.4	675	B										1616	07
64	21.78	4	558	1.2	4.7	675	B										1318	08
56	25.04	4	642	1.1	4.1	675	B										1316	09
47.9	29.23	4	750	0.9	3.5	675	B										1314	10
45.7	30.65	3	592	1.1	3.4	675	B										1116	11
39.1	35.78	3	691	1.0	2.9	675	B										1114	12
36.3	38.55	2.2	548	1.1	2.3	580	B										818	13
31.6	44.32	2.2	630	1.1	2.3	665	B										816	14
27.1	51.74	2.2	735	0.9	2.0	675	B										814	15
22.9	61.03	1.1	437	1.1	1.2	480	B										616	16
19.6	71.25	1.1	510	1.1	1.2	560	B										614	17

The dynamic efficiency is **0.96** for all ratios

Motor Flanges Available Flange Motore Disponibili
B) Supplied with Reduction Bushing Fornito con Bussola di Riduzione
B) Available on Request without reduction bushing Disponibile a Richiesta senza Bussola di Riduzione
C) Motor Flange Holes Position Posizione Fori Flangia Motore

EN Unit **H62C** is supplied with synthetic oil for lifetime lubrication, no maintenance is necessary. See table 1 for lubrication and recommended quantity. In table 2 please see possible radial loads and axial loads on the gearbox.

I Il riduttore **H62C** viene fornito completo di olio sintetico per la lubrificazione permanente e non necessita di alcuna manutenzione. Vedi tab.1 per oli e quantità consigliati. In tab.2 sono presenti i carichi radiali e assiali applicabili al riduttore.

D Das Getriebe **H62C** ist mit synthetischem Öl gefüllt und ist lebensdauergeschmiert. In Tabelle 1 ist die Schmiermenge und das empfohlene Schmiermittel angegeben. In Tabelle 2 sind die zulässigen Radial - und Axialbelastungen des Getriebes aufgeführt.

F Le réducteur **H62C** est fourni complet avec de l'huile synthétique pour la lubrification permanente et ne nécessite aucun entretien. Voir tableau 1 concernant les huiles et les quantités conseillées. Les charges radiales et axiales applicables au réducteur sont précisées dans le tableau 2.

E El reductor tamaño **H62C** se suministra, lubricado de por vida con aceite sintético y no requieren mantenimiento alguna. Ver tabla 1, para cantidades y aceites recomendados. En la tabla 2, se encuentran las cargas radiales y axiales admitidas por el reductor.

Standard supplied	For these mounting position specify in the order or add oil					
	Per queste posizioni specificare in fase d'ordine o aggiungere olio					
B3	B6	B7	B8	V5	V6	V8
2.25 LT	3.20 LT	3.00 LT	2.25 LT	4.35 LT	2.35 LT	Ask
SHELL Omala S4 WE 320			ENI Telium VSF 320			

For all details on lubrication and plugs check our website **tab. 1**
Per maggiori dettagli su lubrificazione e tappi olio vedi il nostro sito web

RADIAL AND AXIAL LOADS

Output shaft
Albero di uscita

$F_{eq} = F_R \cdot \frac{149.5}{X+119.5}$

n_2	FA	FR	n_2	FA	FR	n_2	FA	FR
300	600	3000	140	720	3600	70	940	4700
250	640	3200	120	740	3700	40	1220	6100
200	690	3460	85	860	4300	15	1300	6500

On request reinforced bearings to increase loads.
A richiesta cuscinetti rinforzati per aumentare i carichi.

Input shaft
Albero in entrata

n_1	FA	FR
1400	450	2250
900	500	2500
500	600	3000

tab. 2

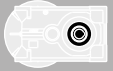

QUICK SELECTION / Selezione veloce

input speed (n_1) = 1400 min⁻¹

Output Speed n_2 [min ⁻¹]	Ratio i	Motor power P_{1M} [kW]	Output torque M_{2M} [Nm]	Service factor $f.s.$	Nominal power P_{1R} [kW]	Nominal torque M_{2R} [Nm]	Available B5 motor flanges				Available B14 motor flanges			Output Shaft 	Ratios code
							-B	-C	-D	-E	-Q	-R	-T		
							63	71	80	90	71	80	90		
22.6	61.89	1.5	594	1.1	1.7	675	B				C	C		191318	01
19.7	71.16	1.5	683	1.0	1.5	675	B				C	C		191316	02
17.0	82.48	1.5	792	0.9	1.3	675	B				C	C		171316	03
14.5	96.29	1.1	675	1.0	1.1	675	B				C	C		171314	04
13.9	100.51	1.1	705	1.0	1.0	675	B				C	C		131318	05
12.1	115.56	0.75	556	1.2	0.91	675	B				C	C		131316	06
11.1	125.96	0.75	606	1.1	0.82	665	B				C	C		190816	07
10.4	134.91	0.75	649	1.0	0.78	675	B				C	C		131314	08
9.5	147.05	0.75	707	1.0	0.72	675	B				C	C		190814	09
8.2	170.44	0.55	605	1.1	0.62	675	B				C	C		170814	10
7.6	184.15	0.55	653	1.0	0.57	675	B				C	C		101314	11
6.8	205.87	0.55	730	0.9	0.51	675	B				C	C		91316	12
5.8	240.34	0.37	570	1.2	0.44	675	B				C	C		91314	13
5.0	279.22	0.37	662	1.0	0.37	665	B				C	C		100816	14
4.3	325.97	0.37	773	0.9	0.32	675	B				C	C		100814	15
3.8	364.41	0.25	583	1.1	0.28	665	B				C	C		90816	16
3.3	425.43	0.25	681	1.0	0.25	675	B				C	C		90814	17
2.9	481.19	0.18	589	1.1	0.22	665	B				C	C		70816	18
2.5	561.76	0.18	687	1.0	0.19	675	B				C	C		70814	19

The dynamic efficiency is **0.94** for all ratios

Motor Flanges Available Flange Motore Disponibili
B) Supplied with Reduction Bushing Fornito con Bussola di Riduzione
B) Available on Request without reduction bushing Disponibile a Richiesta senza Bussola di Riduzione
C) Motor Flange Holes Position Posizione Fori Flangia Motore

EN Unit **H63C** is supplied with synthetic oil for lifetime lubrication, no maintenance is necessary. See table 1 for lubrication and recommended quantity. In table 2 please see possible radial loads and axial loads on the gearbox.

I Il riduttore **H63C** viene fornito completo di olio sintetico per la lubrificazione permanente e non necessita di alcuna manutenzione. Vedi tab.1 per oli e quantità consigliati. In tab.2 sono presenti i carichi radiali e assiali applicabili al riduttore.

D Das Getriebe **H63C** ist mit synthetischem Öl gefüllt und ist lebensdauergeschmiert. In Tabelle 1 ist die Schmiermenge und das empfohlene Schmiermittel angegeben. In Tabelle 2 sind die zulässigen Radial- und Axialbelastungen des Getriebes aufgeführt.

F Le réducteur **H63C** est fourni complet avec de l'huile synthétique pour la lubrification permanente et ne nécessite aucun entretien. Voir tableau 1 concernant les huiles et les quantités conseillées. Les charges radiales et axiales applicables au réducteur sont précisées dans le tableau 2.

E El reductor tamaño **H63C** se suministra, lubricado de por vida con aceite sintético y no requieren mantenimiento alguna. Ver tabla 1, para cantidades y aceites recomendados. En la tabla 2, se encuentran las cargas radiales y axiales admitidas por el reductor.

Standard supplied	For these mounting position specify in the order or add oil Per queste posizioni specificare in fase d'ordine o aggiungere olio							
B3	B6	B7	B8	V5	V6	V8	V8	V8
2.35 LT	3.85 LT	3.15 LT	2.35 LT	4.55 LT	2.50 LT	Ask	Ask	Ask
SHELL Omala S4 WE 320				ENI Telium VSF 320				

For all details on lubrication and plugs check our website **tab. 1**
Per maggiori dettagli su lubrificazione e tappi olio vedi il nostro sito web

RADIAL AND AXIAL LOADS

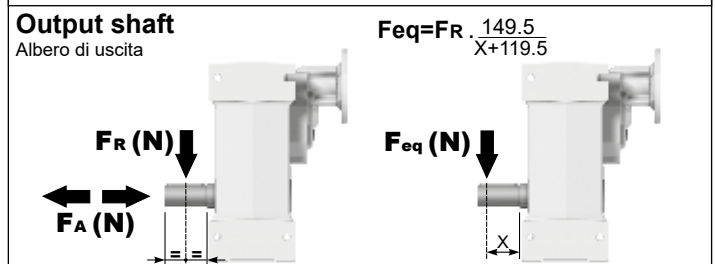

n_2	FA	FR	n_2	FA	FR	n_2	FA	FR
300	600	3000	140	720	3600	70	940	4700
250	640	3200	120	740	3700	40	1220	6100
200	690	3460	85	860	4300	15	1300	6500

On request reinforced bearings to increase loads.

A richiesta cuscinetti rinforzati per aumentare i carichi.

Input shaft Albero in entrata	n_1	FA	FR
	1400	240	1200
	900	280	1400
	500	340	1700

tab. 2

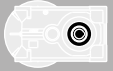

QUICK SELECTION / Selezione veloce

input speed (n_1) = 1400 min⁻¹

Output Speed n_2 [min ⁻¹]	Ratio i	Motor power P_{1M} [kW]	Output torque M_{2M} [Nm]	Service factor f.s.	Nominal power P_{1R} [kW]	Nominal torque M_{2R} [Nm]	Available B5 motor flanges				B14 motor flanges				Output Shaft		
							-G				-	-	-	-	-		
227	6.17	9	371	1.2	10.9	450					not available				18111	standard	01
198	7.06	9	425	1.4	12.7	600									16113	ø40	02
170	8.21	9	494	1.4	12.2	670									14115	ø45	03
The dynamic efficiency is 0.98 for all ratios											On request						

A Motor Flanges Available
Flange Motore Disponibili

B Supplied with Reduction Bushing
Fornito con Bussola di Riduzione

B Available on Request without reduction bushing
Disponibile a Richiesta senza Bussola di Riduzione

C Motor Flange Holes Position
Posizione Fori Flangia Motore

EN Unit **H71C** is supplied without lubricant and equipped with a breather, level and drain plugs. User can add mineral oil keeping existing plugs. Should the user wish to fill it with synthetic oil, it is recommended to replace the existing plugs with a closed plug.
See table 1 for lubrication and recommended quantity.
In table 2 please see possible radial loads and axial loads on the gearbox.

I Il riduttore tipo **H71C** è fornito privo di lubrificazione con tappi di sfiato, livello e scarico olio. L'utente può immettere olio minerale mantenendo i tappi esistenti. Se immetterà olio sintetico, dovrà sostituire i tappi esistenti con altri tipo chiuso.
Tab.1 per oli e quantità consigliati.
Tab.2 carichi radiali e assiali applicabili al riduttore.

D Das Getriebe der Baugröße **H71C** wird ohne Schmiermittel geliefert. Es ist jedoch mit Einfüllschraube, Überdruckventil und Ablassschraube ausgerüstet. Das benötigte mineralische Öl kann über die Einfüllschraube eingefüllt werden. Sollte synthetisches Öl bevorzugt werden, so ist sind das eingebaute Überdruckventil durch eine geschlossenen Schraube zu ersetzen.
In Tabelle 1 ist die Schmiermenge und das empfohlene Schmiermittel angegeben
In Tabelle 2 sind die zulässigen Radial - und Axialbelastungen des Getriebes aufgeführt.

F Le réducteur de type **H71C** est fourni sans lubrification et avec un bouchon de remplissage, de niveau et d'évacuation de l'huile. L'utilisateur peut y verser de l'huile minérale en conservant les bouchons existants. S'il y versera de l'huile synthétique, il devra substituer les bouchons existants avec d'autres bouchons de type fermé.
Voir tableau 1 concernant les huiles et les quantités conseillées.
Voir tableau 2 concernant les charges radiales et axiales applicables au réducteur

E El reductor tamaño **H71C** se suministra sin lubricante, provisto de tapones de respiración, nivel y descarga de aceite. El usuario puede utilizar aceite mineral, manteniendo los tapones existentes. Si prefiere utilizar aceite sintético deberá sustituir los tapones existentes por tapones ciegos. La prerreducción se suministra con tapones ciegos, lubricado de por vida con aceite sintético. Ver tabla 1, para cantidades y aceites recomendados. En la tabla 2, se encuentran las cargas radiales y axiales admitidas por el reductor.

B3	B6	B7	B8	V5	V6	V8
3.20 LT	4.65 LT	4.00 LT	3.20 LT	6.00 LT	3.10 LT	Ask
SHELL Omala S2 GX 460				ENI Blasias 460		

For all details on lubrication and plugs check our website **tab. 1**
Per maggiori dettagli su lubrificazione e tappi olio vedi il nostro sito web

RADIAL AND AXIAL LOADS

Output shaft
Albero di uscita

$F_{eq} = F_R \cdot \frac{174.5}{X+134.5}$

n_2	F_A	F_R	n_2	F_A	F_R	n_2	F_A	F_R
300	740	3700	140	860	4300	70	1020	5100
250	800	4000	120	900	4500	40	1300	6500
200	830	4150	85	970	4850	15	1700	8500

On request reinforced bearings to increase loads.
A richiesta cuscinetti rinforzati per aumentare i carichi.

tab. 2

PH71C... Basic gearbox
Riduttore base

Gearbox weight
peso riduttore **51.0 kg**

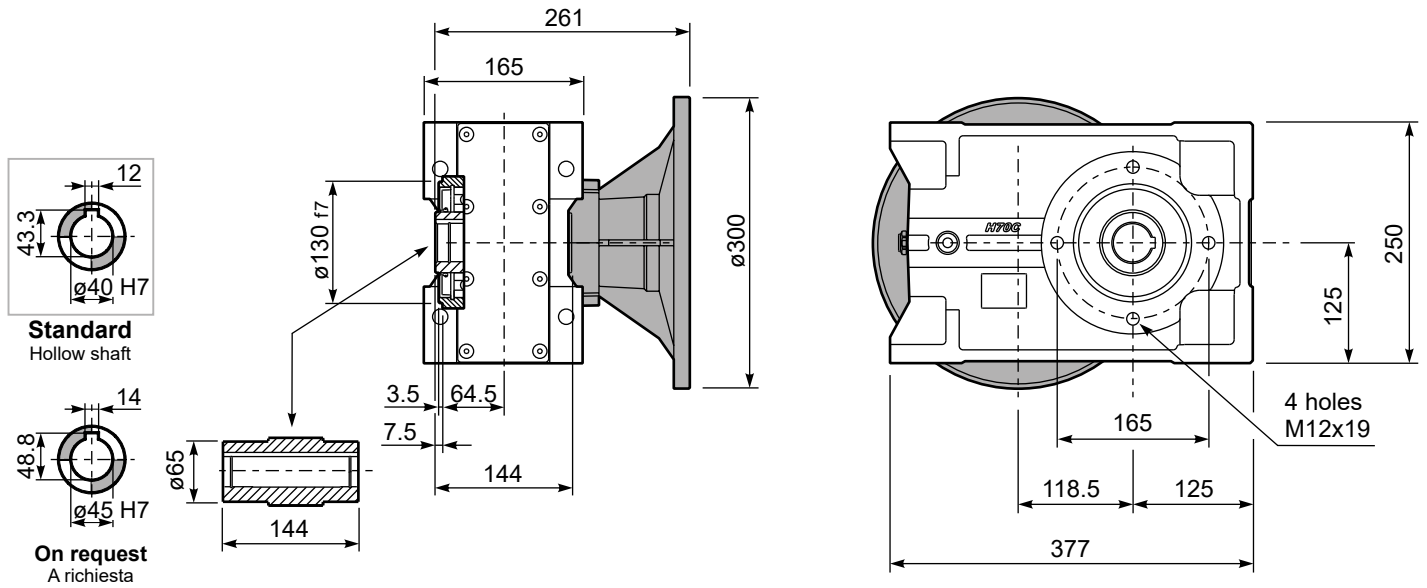

PH71C...-F Output flange
Flangia uscita

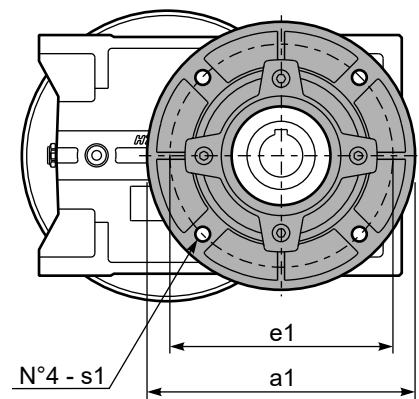
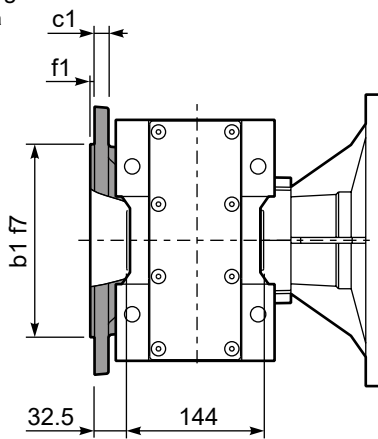

Available output flanges
Flange di uscita

a1 ø	b1	c1	e1	f1	s1	Kit code
250	180	13	215	3	14	KF70.9.011
300	230	16	265	4	14	KF70.9.012

PH71C...-N Feet
Piedini

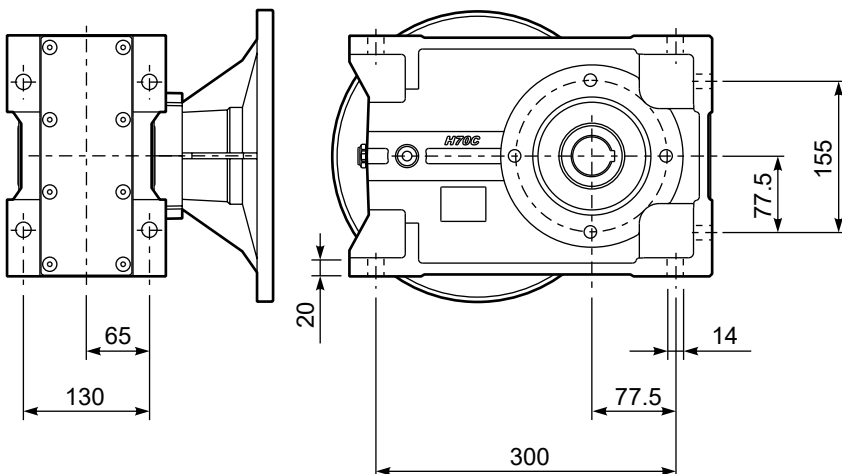

PH71C A... Single output shaft
Albero uscita semplice

Kit. Cod KF70.5.028

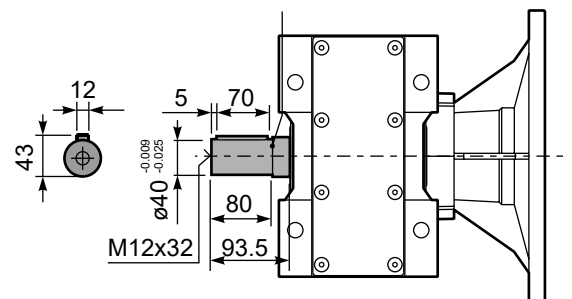

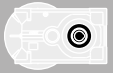

QUICK SELECTION / Selezione veloce

input speed (n_1) = 1400 min⁻¹

Output Speed n_2 [min ⁻¹]	Ratio i	Motor power P_{1M} [kW]	Output torque M_{2M} [Nm]	Service factor $f.s.$	Nominal power P_{1R} [kW]	Nominal torque M_{2R} [Nm]	Available B5 motor flanges					Available B14 motor flanges				Output Shaft 	Ratios code
							-C	-D	-E	-F	-G	-R	-T	-U	-V		
							71	80	90	100 112	132	80	90	100 112	132		
175	8.02	9	473	1.1	9.9	520	B									3018	01
152	9.18	9	541	1.1	9.8	590	B									3016	02
131	10.68	9	630	1.1	9.7	680	B									3014	03
93	15.11	7.5	717	1.1	7.8	775	B									2018	04
81	17.30	7.5	821	1.1	7.8	885	B									2016	05
70	20.13	7.5	955	0.9	6.8	900	B									2014	06
60	23.39	5.5	820	1.1	5.9	900	B									1616	07
51	27.21	5.5	954	0.9	5.1	900	B									1614	08
46.0	30.42	4	780	1.2	4.5	900	B									1316	09
39.6	35.38	4	907	1.0	3.9	900	B									1314	10
37.6	37.24	3	719	1.2	3.7	895	B									1116	11
32.3	43.31	3	836	1.1	3.2	900	B									1114	12
29.8	47.02	2.2	668	1.1	2.3	705	B									818	13
26.0	53.85	2.2	765	1.1	2.3	810	B									816	14
22.4	62.63	2.2	890	1.0	2.2	900	B									814	15
18.9	74.16	1.1	531	1.1	1.2	585	B									616	16
16.2	86.25	1.1	617	1.1	1.2	680	B									614	17

The dynamic efficiency is **0.96** for all ratios

- Motor Flanges Available
Flange Motore Disponibili
- B) Supplied with Reduction Bushing
Fornito con Bussola di Riduzione
- C) Available on Request without reduction bushing
Disponibile a Richiesta senza Bussola di Riduzione
- C) Motor Flange Holes Position
Posizione Fori Flangia Motore

EN Unit **H72C** is supplied without lubricant and equipped with a breather, level and drain plugs. User can add mineral oil keeping existing plugs. Should the user wish to fill it with synthetic oil, it is recommended to replace the existing plugs with a closed plug. See table 1 for lubrication and recommended quantity. In table 2 please see possible radial loads and axial loads on the gearbox.

I Il riduttore tipo **H72C** è fornito privo di lubrificazione con tappi di sfiato, livello e scarico olio. L'utente può immettere olio minerale mantenendo i tappi esistenti. Se immetterà olio sintetico, dovrà sostituire i tappi esistenti con altri tipo chiuso. Tab.1 per oli e quantità consigliati. Tab.2 carichi radiali e assiali applicabili al riduttore.

D Das Getriebe der Baugröße **H72C** wird ohne Schmiermittel geliefert. Es ist jedoch mit Einfüllschraube, Überdruckventil und Ablassschraube ausgerüstet. Das benötigte mineralische Öl kann über die Einfüllschraube eingefüllt werden. Sollte synthetisches Öl bevorzugt werden, so ist sind das eingebaute Überdruckventil durch eine geschlossenen Schraube zu ersetzen. In Tabelle 1 ist die Schmiermenge und das empfohlene Schmiermittel angegeben. In Tabelle 2 sind die zulässigen Radial - und Axialbelastungen des Getriebes aufgeführt.

F Le réducteur de type **H72C** est fourni sans lubrification et avec un bouchon de remplissage, de niveau et d'évacuation de l'huile. L'utilisateur peut y verser de l'huile minérale en conservant les bouchons existants. S'il y versera de l'huile synthétique, il devra substituer les bouchons existants avec d'autres bouchons de type fermé. Voir tableau 1 concernant les huiles et les quantités conseillées. Voir tableau 2 concernant les charges radiales et axiales applicables au réducteur.

E El reductor tamaño **H72C** se suministra sin lubricante, provisto de tapones de respiración, nivel y descarga de aceite. El usuario puede utilizar aceite mineral, manteniendo los tapones existentes. Si prefiere utilizar aceite sintético deberá sustituir los tapones existentes por tapones ciegos. La prerreducción se suministra con tapones ciegos, lubricado de por vida con aceite sintético. Ver tabla 1, para cantidades y aceites recomendados. En la tabla 2, se encuentran las cargas radiales y axiales admitidas por el reductor.

B3	B6	B7	B8	V5	V6	V8
3.20 LT	4.65 LT	4.00 LT	3.20 LT	6.20 LT	3.10 LT	Ask
SHELL Omala S2 GX 460				ENI Blasias 460		

For all details on lubrication and plugs check our website
Per maggiori dettagli su lubrificazione e tappi olio vedi il nostro sito web **tab. 1**

RADIAL AND AXIAL LOADS

Output shaft
Albero di uscita

$F_{eq} = FR \cdot \frac{174.5}{X+134.5}$

n_2	FA	FR	n_2	FA	FR	n_2	FA	FR
300	740	3700	140	860	4300	70	1020	5100
250	800	4000	120	900	4500	40	1300	6500
200	830	4150	85	970	4850	15	1700	8500

On request reinforced bearings to increase loads.
A richiesta cuscinetti rinforzati per aumentare i carichi.

Input shaft
Albero in entrata

n_1	FA	FR
1400	450	2250
900	500	2500
500	600	3000

tab. 2

PH72C... Basic gearbox
Riduttore base

M. flanges	Kit code	øF	A
71B5	K023.4.041	160	238.5
80/90B5	K023.4.042	200	240.5
100/112B5	K023.4.043	250	249.5
132B5	KC51.4.043	300	270.5
80B14	K085.4.046	120	240.5
90B14	K085.4.045	140	240.5
100/112B14	K085.4.047	160	249.5
132B14	KC51.4.041	200	270.5

Standard
Hollow shaft

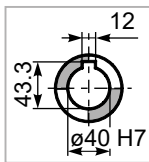

On request
A richiesta

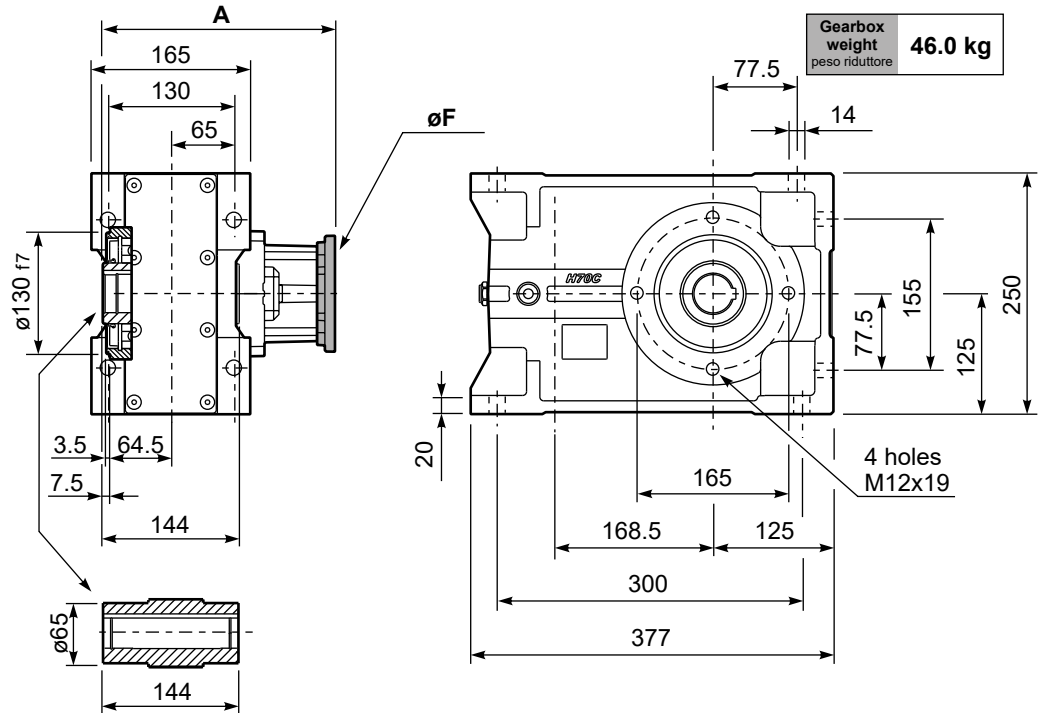
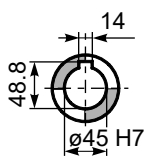

PH72C...-F Output flange
Flangia uscita

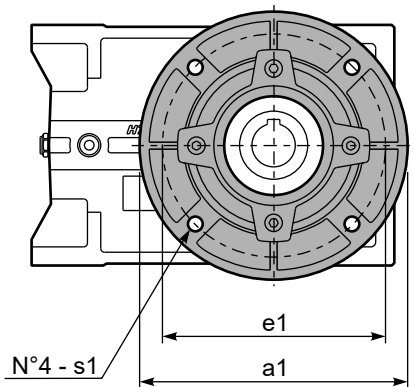
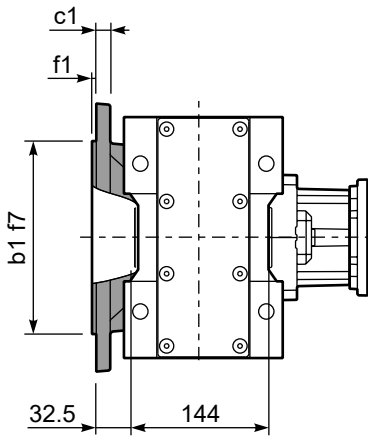

PH72C D... Shrink disk
Calettatore

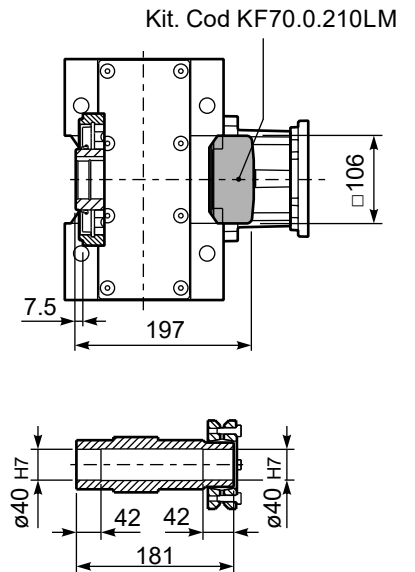

Available output flanges

Flange di uscita

a1 ø	b1	c1	e1	f1	s1	Kit code
250	180	13	215	3	14	KF70.9.011
300	230	16	265	4	14	KF70.9.012

RH72C... Input Shaft
Albero in entrata

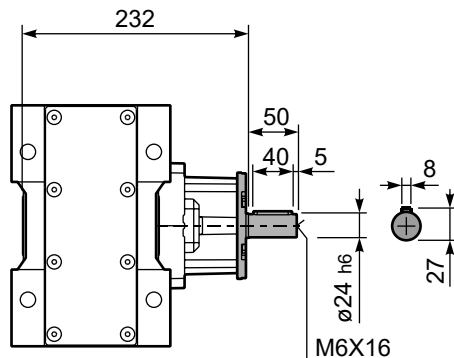

PH72C A... Single output shaft
Albero uscita semplice

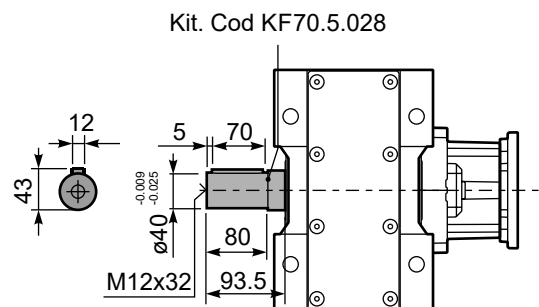

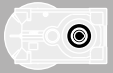

QUICK SELECTION / Selezione veloce

input speed (n_1) = 1400 min⁻¹

Output Speed n_2 [min ⁻¹]	Ratio i	Motor power P_{1M} [kW]	Output torque M_{2M} [Nm]	Service factor $f.s.$	Nominal power P_{1R} [kW]	Nominal torque M_{2R} [Nm]	Available B5 motor flanges				Available B14 motor flanges			Output Shaft 	Ratios code
							-B	-C	-D	-E	-Q	-R	-T		
							63	71	80	90	71	80	90		
18.5	75.50	1.5	725	1.1	1.7	825	B				C	C		191318	01
16.2	86.47	1.5	830	1.1	1.6	900	B				C	C		191316	02
14.0	100.22	1.5	962	0.9	1.4	900	B				C	C		171316	03
12.0	116.56	1.1	817	1.1	1.2	900	B				C	C		171314	04
10.2	136.82	1.1	959	0.9	1.0	900	B				C	C		151314	05
9.1	153.05	0.75	736	1.1	0.83	810	B				C	C		190816	06
8.6	163.31	0.75	785	1.1	0.86	900	B				C	C		131314	07
7.9	178.01	0.75	856	1.1	0.79	900	B				C	C		190814	08
7.3	191.67	0.75	922	1.0	0.73	900	B				C	C		101316	09
6.8	206.32	0.75	992	0.9	0.68	900	B				C	C		170814	10
6.3	222.92	0.55	791	1.1	0.63	900	B				C	C		101314	11
5.8	242.18	0.55	859	1.0	0.58	900	B				C	C		150814	12
5.6	250.15	0.55	888	1.0	0.56	900	B				C	C		91316	13
4.8	289.08	0.55	1026	0.9	0.49	900	B				C	C		130814	14
4.2	330.31	0.37	783	1.1	0.42	890	B				C	C		71316	15
3.5	394.59	0.37	936	1.0	0.36	900	B				C	C		100814	16
2.7	514.99	0.25	824	1.1	0.27	900	B				C	C		90814	17
2.1	680.03	0.18	832	1.1	0.21	900	B				C	C		70814	18

The dynamic efficiency is **0.94** for all ratios

Motor Flanges Available Flange Motore Disponibili B) Supplied with Reduction Bushing Fornito con Bussola di Riduzione B) Available on Request without reduction bushing Disponibile a Richiesta senza Bussola di Riduzione C) Motor Flange Holes Position Posizione Fori Flangia Motore

EN Unit **H73C** is supplied without lubricant and equipped with a breather, level and drain plugs. User can add mineral oil keeping existing plugs. Should the user wish to fill it with synthetic oil, it is recommended to replace the existing plugs with a closed plug. See table 1 for lubrication and recommended quantity. In table 2 please see possible radial loads and axial loads on the gearbox.

I Il riduttore tipo **H73C** è fornito privo di lubrificazione con tappi di sfiato, livello e scarico olio. L'utente può immettere olio minerale mantenendo i tappi esistenti. Se immetterà olio sintetico, dovrà sostituire i tappi esistenti con altri tipo chiuso. Tab.1 per oli e quantità consigliati. Tab.2 carichi radiali e assiali applicabili al riduttore.

D Das Getriebe der Baugröße **H73C** wird ohne Schmiermittel geliefert. Es ist jedoch mit Einfüllschraube, Überdruckventil und Ablassschraube ausgerüstet. Das benötigte mineralische Öl kann über die Einfüllschraube eingefüllt werden. Sollte synthetisches Öl bevorzugt werden, so ist sind das eingebaute Überdruckventil durch eine geschlossenen Schraube zu ersetzen. In Tabelle 1 ist die Schmiermenge und das empfohlene Schmiermittel angegeben. In Tabelle 2 sind die zulässigen Radial - und Axialbelastungen des Getriebes aufgeführt.

F Le réducteur de type **H73C** est fourni sans lubrification et avec un bouchon de remplissage, de niveau et d'évacuation de l'huile. L'utilisateur peut y verser de l'huile minérale en conservant les bouchons existants. S'il y versera de l'huile synthétique, il devra substituer les bouchons existants avec d'autres bouchons de type fermé. Voir tableau 1 concernant les huiles et les quantités conseillées. Voir tableau 2 concernant les charges radiales et axiales applicables au réducteur.

E El reductor tamaño **H73C** se suministra sin lubricante, provisto de tapones de respiración, nivel y descarga de aceite. El usuario puede utilizar aceite mineral, manteniendo los tapones existentes. Si prefiere utilizar aceite sintético deberá sustituir los tapones existentes por tapones ciegos. La prerreducción se suministra con tapones ciegos, lubricado de por vida con aceite sintético. Ver tabla 1, para cantidades y aceites recomendados. En la tabla 2, se encuentran las cargas radiales y axiales admitidas por el reductor.

B3	B6	B7	B8	V5	V6	V8
3.30 LT	5.70 LT	4.15 LT	3.30 LT	6.40 LT	3.25 LT	Ask
SHELL Omala S2 GX 460				ENI Blasias 460		

For all details on lubrication and plugs check our website **tab. 1**
Per maggiori dettagli su lubrificazione e tappi olio vedi il nostro sito web

RADIAL AND AXIAL LOADS

Output shaft
Albero di uscita

$F_{eq} = F_R \cdot \frac{174.5}{X+134.5}$

n_2	FA	FR	n_2	FA	FR	n_2	FA	FR
300	740	3700	140	860	4300	70	1020	5100
250	800	4000	120	900	4500	40	1300	6500
200	830	4150	85	970	4850	15	1700	8500

On request reinforced bearings to increase loads.
A richiesta cuscinetti rinforzati per aumentare i carichi.

Input shaft
Albero in entrata

n_1	FA	FR
1400	400	2000
900	440	2200
500	440	2200

tab. 2



QUICK SELECTION / Selezione veloce

input speed (n_1) = 1400 min⁻¹

Output Speed n_2 [min ⁻¹]	Ratio i	Motor power P_{1M} [kW]	Output torque M_{2M} [Nm]	Service factor f.s.	Nominal power P_{1R} [kW]	Nominal torque M_{2R} [Nm]	Available B5 motor flanges		B14 motor flanges				Output Shaft		
							-H	-I	-	-	-	-			Ratios code
							160	180	-	-	-	-			
528	2.65	22	374	1.7	36.7	650			not available				2361	standard	01
409	3.42	22	483	1.6	32.8	750							1965	ø50	02
304	4.60	22	649	1.5	30.9	950							1569		03
256	5.46	22	771	1.3	27.4	1000							1371	ø55	04
211	6.64	22	937	1.3	26.5	1175							1173	On request	05

The dynamic efficiency is **0.98** for all ratios

A) Motor Flanges Available
Flange Motore Disponibili

B) Supplied with Reduction Bushing
Fornito con Bussola di Riduzione

B) Available on Request without reduction bushing
Disponibile a Richiesta senza Bussola di Riduzione

C) Motor Flange Holes Position
Posizione Fori Flangia Motore

EN Unit **H81C** is supplied without lubricant and equipped with a breather, level and drain plugs. User can add mineral oil keeping existing plugs. Should the user wish to fill it with synthetic oil, it is recommended to replace the existing plugs with a closed plug. See table 1 for lubrication and recommended quantity. In table 2 please see possible radial loads and axial loads on the gearbox.

I Il riduttore tipo **H81C** è fornito privo di lubrificazione con tappi di sfiato, livello e scarico olio. L'utente può immettere olio minerale mantenendo i tappi esistenti. Se immetterà olio sintetico, dovrà sostituire i tappi esistenti con altri tipo chiuso. Tab.1 per oli e quantità consigliati. Tab.2 carichi radiali e assiali applicabili al riduttore.

D Das Getriebe der Baugröße **H81C** wird ohne Schmiermittel geliefert. Es ist jedoch mit Einfüllschraube, Überdruckventil und Ablassschraube ausgerüstet. Das benötigte mineralische Öl kann über die Einfüllschraube eingefüllt werden. Sollte synthetisches Öl bevorzugt werden, so ist sind das eingebaute Überdruckventil durch eine geschlossenen Schraube zu ersetzen. In Tabelle 1 ist die Schmiermenge und das empfohlene Schmiermittel angegeben. In Tabelle 2 sind die zulässigen Radial - und Axialbelastungen des Getriebes aufgeführt.

F Le réducteur de type **H81C** est fourni sans lubrification et avec un bouchon de remplissage, de niveau et d'évacuation de l'huile. L'utilisateur peut y verser de l'huile minérale en conservant les bouchons existants. S'il y versera de l'huile synthétique, il devra substituer les bouchons existants avec d'autres bouchons de type fermé. Voir tableau 1 concernant les huiles et les quantités conseillées. Voir tableau 2 concernant les charges radiales et axiales applicables au réducteur

E El reductor tamaño **H81C** se suministra sin lubricante, provisto de tapones de respiración, nivel y descarga de aceite. El usuario puede utilizar aceite mineral, manteniendo los tapones existentes. Si prefiere utilizar aceite sintético deberá sustituir los tapones existentes por tapones ciegos. La prerreducción se suministra con tapones ciegos, lubricado de por vida con aceite sintético. Ver tabla 1, para cantidades y aceites recomendados. En la tabla 2, se encuentran las cargas radiales y axiales admitidas por el reductor.

B3	B6	B7	B8	V5	V6	V8
5.70 LT	7.00 LT	7.90 LT	5.70 LT	10.20 LT	5.60 LT	Ask
SHELL Omala S2 GX 460				ENI Blasias 460		

For all details on lubrication and plugs check our website **tab. 1**
Per maggiori dettagli su lubrificazione e tappi olio vedi il nostro sito web

RADIAL AND AXIAL LOADS

Output shaft
Albero di uscita

$F_{eq} = FR \cdot \frac{227.5}{X+177.5}$

n_2	FA	FR	n_2	FA	FR	n_2	FA	FR
300	920	4600	140	1120	5600	70	1400	7000
250	1000	5000	120	1140	5700	40	1800	9000
200	1060	5300	85	1300	6500	15	2400	12000

On request reinforced bearings to increase loads.
A richiesta cuscinetti rinforzati per aumentare i carichi.

tab. 2

PH81C... Basic gearbox
Riduttore base

Gearbox weight **89.0 kg**
peso riduttore

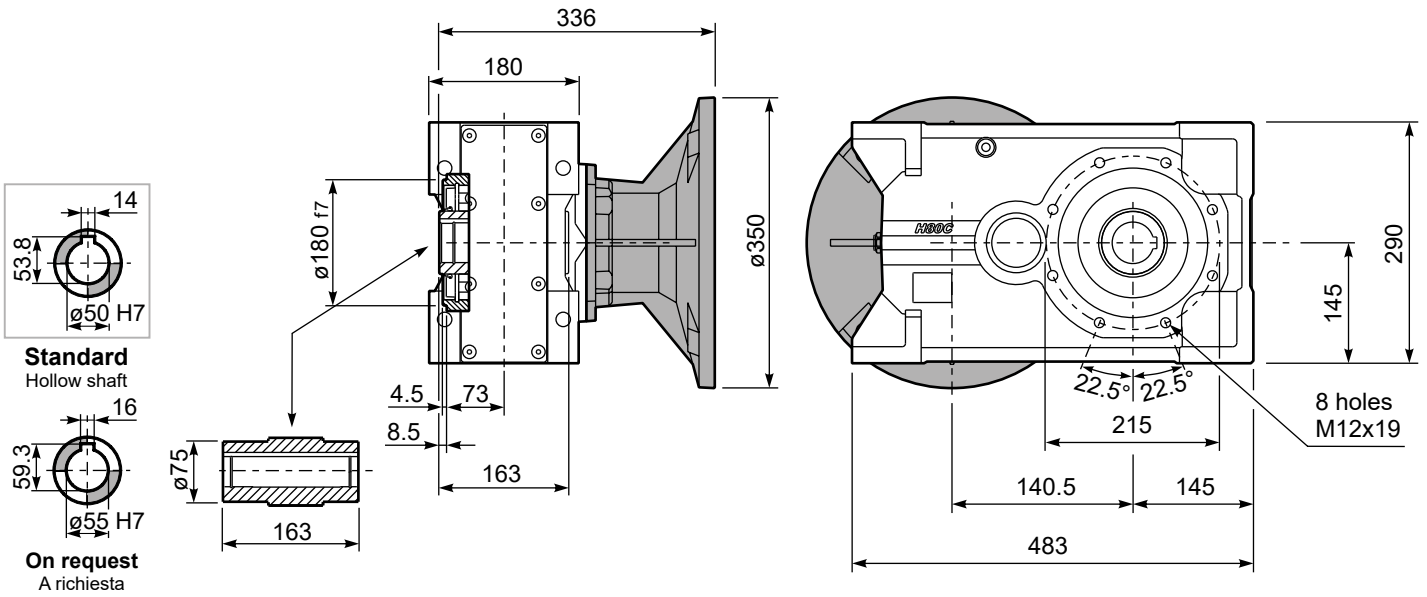

PH81C...-F Output flange
Flangia uscita

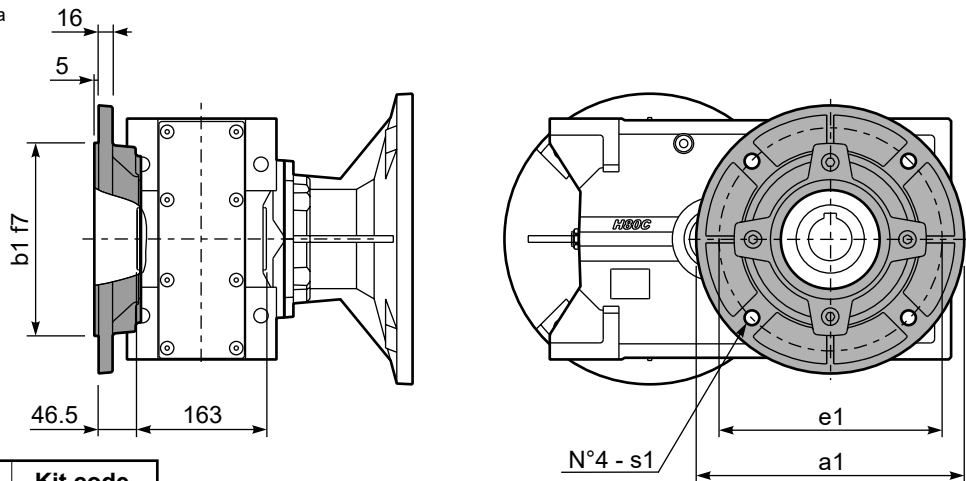

Available output flanges
Flange di uscita

a1 ø	b1	e1	s1	Kit code
300	230	265	14	KF80.9.011
350	250	300	18	KF80.9.012

PH81C...-N Feet
Piedini

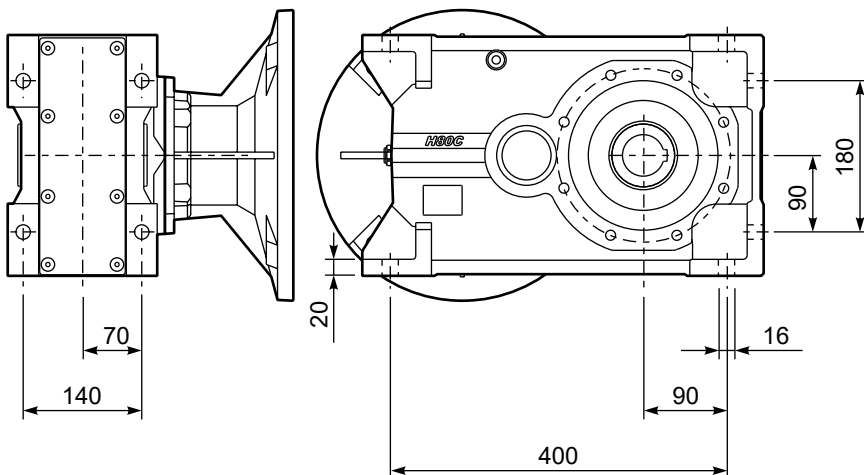

PH81C A... Single output shaft
Albero uscita semplice

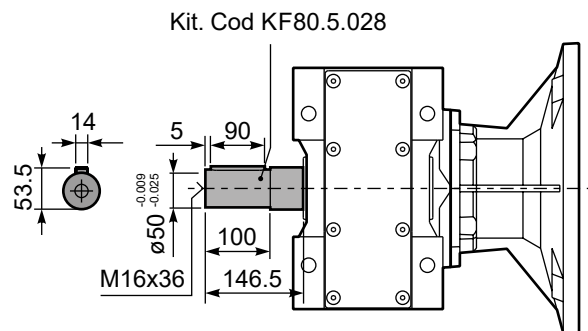

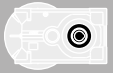

QUICK SELECTION / Selezione veloce

input speed (n_1) = 1400 min⁻¹

Output Speed n_2 [min ⁻¹]	Ratio i	Motor power P_{1M} [kW]	Output torque M_{2M} [Nm]	Service factor f.s.	Nominal power P_{1R} [kW]	Nominal torque M_{2R} [Nm]	B5 motor flanges				B14 motor flanges		Output Shaft 	Ratios code
							-F	-G	-H	-I	-U	-V		
							100 112	132	160	180	100 112	132		
234	5.98	22	827	1.2	25.5	1000						3015	01	
197	7.10	22	982	1.2	25.3	1175						3013	02	
162	8.63	22	1193	1.1	23.9	1350						3011	03	
124	11.27	18.5	1310	1.1	20.3	1500						2015	04	
105	13.38	18.5	1555	1.1	19.4	1700						2013	05	
92	15.24	18.5	1771	1.1	19.0	1900						1615	06	
86	16.26	18.5	1889	1.1	19.7	2100						2011	07	
77	18.09	18.5	2102	1.0	17.7	2100						1613	08	
71	19.82	15	1865	1.1	15.9	2060						1315	09	
64	21.98	15	2069	1.0	14.6	2100						1611	10	
60	23.53	15	2214	0.9	13.6	2100						1313	11	
58	24.25	11	1677	1.2	12.2	1940						1115	12	
48.6	28.80	11	1991	1.1	11.1	2100						1113	13	
40.0	34.99	9	2063	1.0	9.2	2100						1111	14	
33.6	41.64	7.5	1976	1.0	7.2	1960						813	15	
27.7	50.60	5.5	1774	1.2	6.3	2100						811	16	

The dynamic efficiency is **0.96** for all ratios

- Motor Flanges Available
Flange Motore Disponibili
- B) Supplied with Reduction Bushing
Fornito con Bussola di Riduzione
- B) Available on Request without reduction bushing
Disponibile a Richiesta senza Bussola di Riduzione
- C) Motor Flange Holes Position
Posizione Fori Flangia Motore

EN Unit **H82C** is supplied without lubricant and equipped with a breather, level and drain plugs. User can add mineral oil keeping existing plugs. Should the user wish to fill it with synthetic oil, it is recommended to replace the existing plugs with a closed plug.
See table 1 for lubrication and recommended quantity.
In table 2 please see possible radial loads and axial loads on the gearbox.

I Il riduttore tipo **H82C** è fornito privo di lubrificazione con tappi di sfiato, livello e scarico olio. L'utente può immettere olio minerale mantenendo i tappi esistenti. Se immetterà olio sintetico, dovrà sostituire i tappi esistenti con altri tipo chiuso.
Tab.1 per oli e quantità consigliati.
Tab.2 carichi radiali e assiali applicabili al riduttore.

D Das Getriebe der Baugröße **H82C** wird ohne Schmiermittel geliefert. Es ist jedoch mit Einfüllschraube, Überdruckventil und Ablassschraube ausgerüstet. Das benötigte mineralische Öl kann über die Einfüllschraube eingefüllt werden. Sollte synthetisches Öl bevorzugt werden, so ist sind das eingebaute Überdruckventil durch eine geschlossenen Schraube zu ersetzen.
In Tabelle 1 ist die Schmiermenge und das empfohlene Schmiermittel angegeben
In Tabelle 2 sind die zulässigen Radial - und Axialbelastungen des Getriebes aufgeführt.

F Le réducteur de type **H82C** est fourni sans lubrification et avec un bouchon de remplissage, de niveau et d'évacuation de l'huile. L'utilisateur peut y verser de l'huile minérale en conservant les bouchons existants. S'il y versera de l'huile synthétique, il devra substituer les bouchons existants avec d'autres bouchons de type fermé.
Voir tableau 1 concernant les huiles et les quantités conseillées.
Voir tableau 2 concernant les charges radiales et axiales applicables au réducteur

E El reductor tamaño **H82C** se suministra sin lubricante, provisto de tapones de respiración, nivel y descarga de aceite. El usuario puede utilizar aceite mineral, manteniendo los tapones existentes. Si prefiere utilizar aceite sintético deberá sustituir los tapones existentes por tapones ciegos. La prerreducción se suministra con tapones ciegos, lubricado de por vida con aceite sintético.
Ver tabla 1, para cantidades y aceites recomendados.
En la tabla 2, se encuentran las cargas radiales y axiales admitidas por el reductor.

B3	B6	B7	B8	V5	V6	V8
5.60 LT	6.80 LT	7.80 LT	5.60 LT	10.00 LT	5.50 LT	Ask
SHELL Omala S2 GX 460				ENI Blasias 460		

For all details on lubrication and plugs check our website **tab. 1**
Per maggiori dettagli su lubrificazione e tappi olio vedi il nostro sito web

RADIAL AND AXIAL LOADS

Output shaft
Albero di uscita

$F_{eq} = F_R \cdot \frac{227.5}{X+177.5}$

n_2	FA	FR	n_2	FA	FR	n_2	FA	FR
300	920	4600	140	1120	5600	70	1400	7000
250	1000	5000	120	1140	5700	40	1800	9000
200	1060	5300	85	1300	6500	15	2400	12000

On request reinforced bearings to increase loads.
A richiesta cuscinetti rinforzati per aumentare i carichi.

Input shaft
Albero in entrata

n_1	FA	FR
1400	700	3500
900	840	4200
500	900	4500

tab. 2

PH82C... Basic gearbox
Riduttore base

Gearbox weight
peso riduttore **86.0 kg**

M. flanges	Kit code	øF	A
100/112B5	K023.4.043	250	299
132B5	KC51.4.043C	300	320.5
160/180B5	KC86.4.0.43	350	352.5
100/112B14	K085.4.047	160	299
132B14	KC51.4.041C	200	320.5

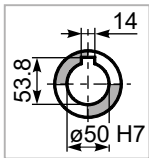

Standard
Hollow shaft

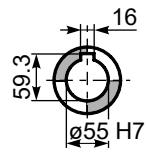

On request
A richiesta

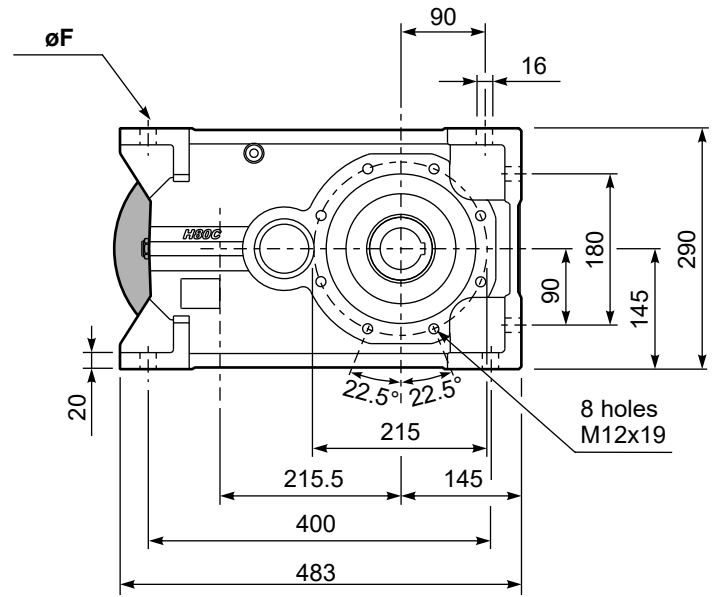
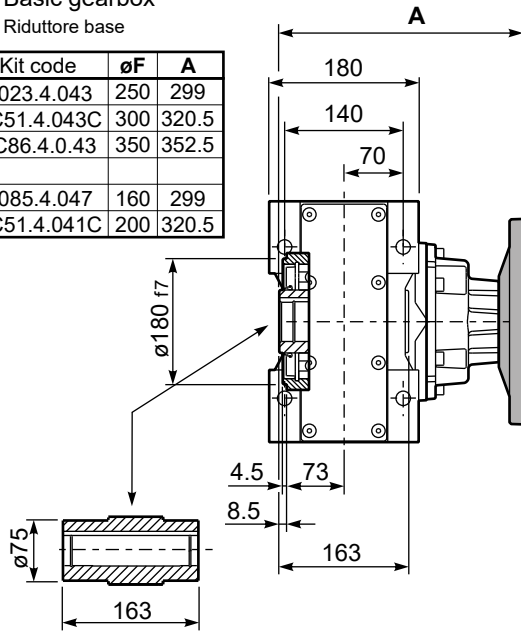

PH82C...-F Output flange
Flangia uscita

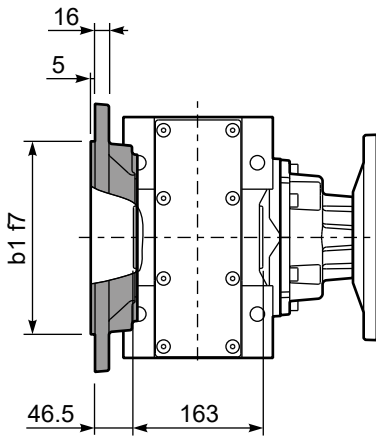

Available output flanges
Flange di uscita

a1 ø	b1	e1	s1	Kit code
300	230	265	14	KF80.9.011
350	250	300	18	KF80.9.012

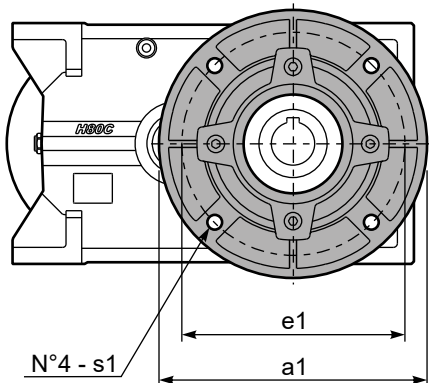

PH82C D... Shrink disk
Calettatore

Kit. Cod KF80.0.210LM

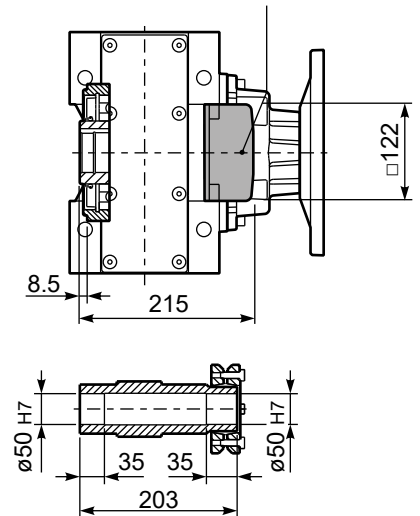

RH82C... Input Shaft
Albero in entrata

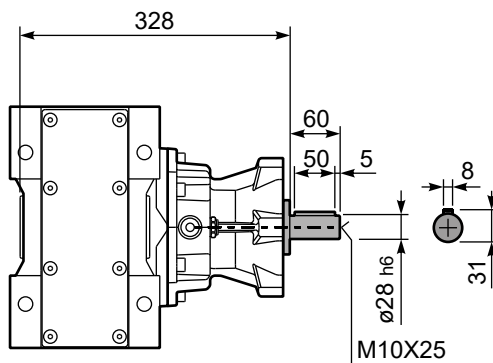

PH82C A... Single output shaft
Albero uscita semplice

Kit. Cod KF80.5.028

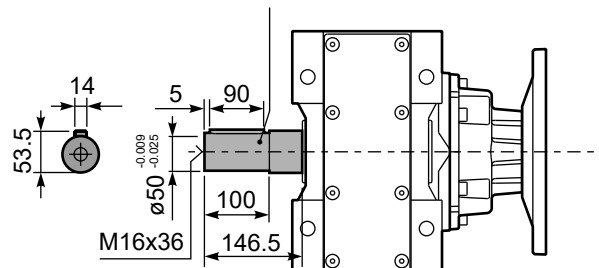

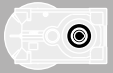

QUICK SELECTION / Selezione veloce

input speed (n_1) = 1400 min⁻¹

Output Speed n_2 [min ⁻¹]	Ratio i	Motor power P_{1M} [kW]	Output torque M_{2M} [Nm]	Service factor f.s.	Nominal power P_{1R} [kW]	Nominal torque M_{2R} [Nm]	Available B5 motor flanges					Available B14 motor flanges				Output Shaft 	Ratios code
							-C	-D	-E	-F	-G	-R	-T	-U	-V		
							71	80	90	100 112	132	80	90	100 112	132		
28.8	48.55	7.5	2257	0.9	6.7	2100	B									201315	01
24.3	57.64	5.5	1980	1.1	5.7	2100	B									201313	02
21.3	65.64	5.5	2255	0.9	5.0	2100	B									161315	03
20.0	70.04	4	1760	1.2	4.7	2100	B									201311	04
18.0	77.93	4	1958	1.1	4.2	2100	B									161313	05
16.4	85.36	4	2145	1.0	3.8	2100	B									131315	06
14.8	94.70	4	2380	0.9	3.5	2100	B									161311	07
13.8	101.35	3	1917	1.1	3.2	2100	B									131313	08
11.4	123.15	3	2330	0.9	2.7	2100	B									131311	09
9.3	150.73	2.2	2100	1.0	2.2	2100	B									111311	10
7.8	179.39	1.5	1722	1.2	1.8	2100	B									81313	11
6.4	217.98	1.5	2093	1.0	1.5	2100	B									81311	12
5.7	247.03	1.1	1732	1.1	1.2	1950	B									61313	13
4.7	300.17	1.1	2105	1.0	1.1	2100	B									61311	14

The dynamic efficiency is **0.94** for all ratios

- Motor Flanges Available
Flange Motore Disponibili
- B) Supplied with Reduction Bushing
Fornito con Bussola di Riduzione
- B) Available on Request without reduction bushing
Disponibile a Richiesta senza Bussola di Riduzione
- C) Motor Flange Holes Position
Posizione Fori Flangia Motore

EN Unit **H83C** is supplied without lubricant and equipped with a breather, level and drain plugs. User can add mineral oil keeping existing plugs. Should the user wish to fill it with synthetic oil, it is recommended to replace the existing plugs with a closed plug. See table 1 for lubrication and recommended quantity. In table 2 please see possible radial loads and axial loads on the gearbox.

I Il riduttore tipo **H83C** è fornito privo di lubrificazione con tappi di sfiato, livello e scarico olio. L'utente può immettere olio minerale mantenendo i tappi esistenti. Se immetterà olio sintetico, dovrà sostituire i tappi esistenti con altri tipo chiuso. Tab.1 per oli e quantità consigliati. Tab.2 carichi radiali e assiali applicabili al riduttore.

D Das Getriebe der Baugröße **H83C** wird ohne Schmiermittel geliefert. Es ist jedoch mit Einfüllschraube, Überdruckventil und Ablassschraube ausgerüstet. Das benötigte mineralische Öl kann über die Einfüllschraube eingefüllt werden. Sollte synthetisches Öl bevorzugt werden, so ist sind das eingebaute Überdruckventil durch eine geschlossenen Schraube zu ersetzen. In Tabelle 1 ist die Schmiermenge und das empfohlene Schmiermittel angegeben. In Tabelle 2 sind die zulässigen Radial - und Axialbelastungen des Getriebes aufgeführt.

F Le réducteur de type **H83C** est fourni sans lubrification et avec un bouchon de remplissage, de niveau et d'évacuation de l'huile. L'utilisateur peut y verser de l'huile minérale en conservant les bouchons existants. S'il y versera de l'huile synthétique, il devra substituer les bouchons existants avec d'autres bouchons de type fermé. Voir tableau 1 concernant les huiles et les quantités conseillées. Voir tableau 2 concernant les charges radiales et axiales applicables au réducteur

E El reductor tamaño **H83C** se suministra sin lubricante, provisto de tapones de respiración, nivel y descarga de aceite. El usuario puede utilizar aceite mineral, manteniendo los tapones existentes. Si prefiere utilizar aceite sintético deberá sustituir los tapones existentes por tapones ciegos. La prerreducción se suministra con tapones ciegos, lubricado de por vida con aceite sintético. Ver tabla 1, para cantidades y aceites recomendados. En la tabla 2, se encuentran las cargas radiales y axiales admitidas por el reductor.

B3	B6	B7	B8	V5	V6	V8
5.80 LT	7.10 LT	8.20 LT	5.80 LT	10.80 LT	6.00 LT	Ask
SHELL Omala S2 GX 460				ENI Blasias 460		

For all details on lubrication and plugs check our website [tab. 1](#)
Per maggiori dettagli su lubrificazione e tappi olio vedi il nostro sito web

RADIAL AND AXIAL LOADS

Output shaft
Albero di uscita

$F_{eq} = F_R \cdot \frac{227.5}{X+177.5}$

n_2	FA	FR	n_2	FA	FR	n_2	FA	FR
300	920	4600	140	1120	5600	70	1400	7000
250	1000	5000	120	1140	5700	40	1800	9000
200	1060	5300	85	1300	6500	15	2400	12000

On request reinforced bearings to increase loads.
A richiesta cuscinetti rinforzati per aumentare i carichi.

Input shaft
Albero in entrata

n_1	FA	FR
1400	450	2250
900	500	2500
500	600	3000

tab. 2

PH83C... Basic gearbox
Riduttore base

Gearbox weight
peso riduttore **81.0 kg**

M. flanges	Kit code	øF	A
71B5	K023.4.041	160	292.5
80/90B5	K023.4.042	200	294.5
100/112B5	K023.4.043	250	303.5
132B5	KC51.4.043	300	324.5
80B14	K085.4.046	120	294.5
90B14	K085.4.045	140	294.5
100/112B14	K085.4.047	160	303.5
132B14	KC51.4.041	200	324.5

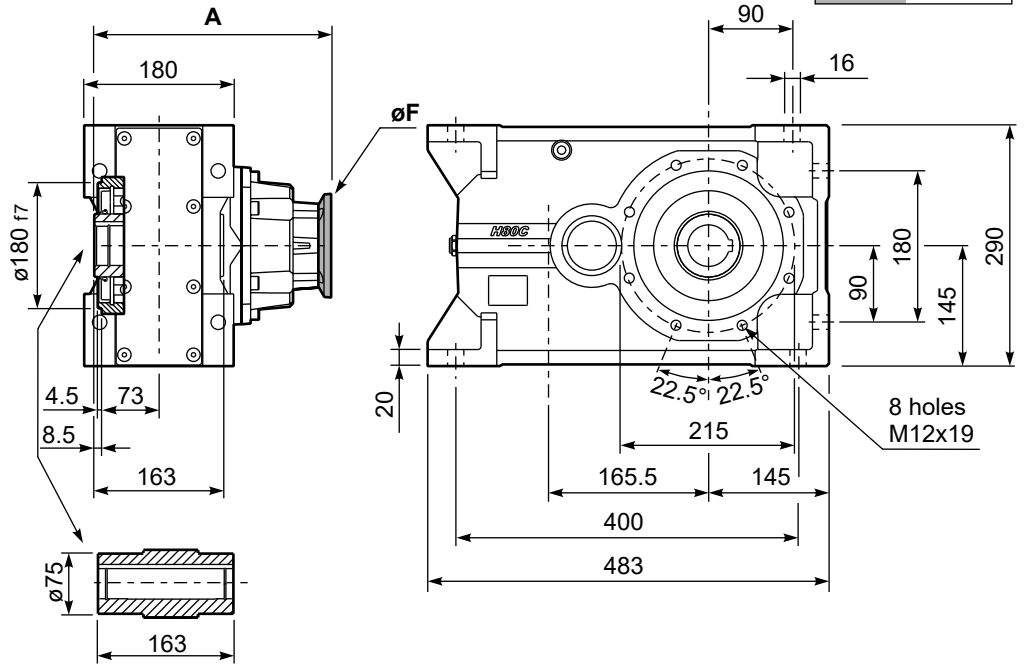

Standard
Hollow shaft

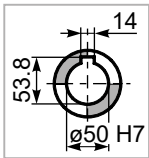

On request
A richiesta

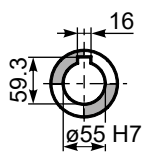

PH83C...-F Output flange
Flangia uscita

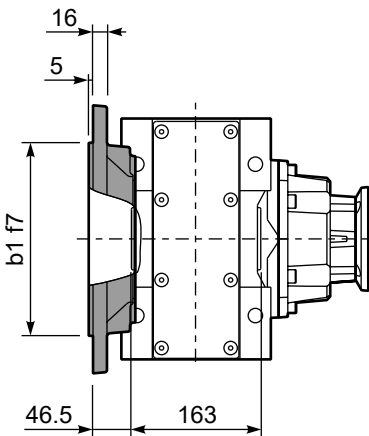

Available output flanges
Flange di uscita

a1 ø	b1	e1	s1	Kit code
300	230	265	14	KF80.9.011
350	250	300	18	KF80.9.012

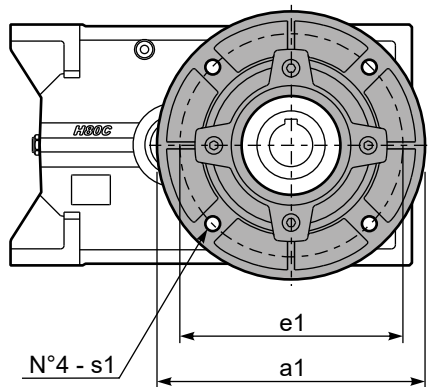

PH83C D... Shrink disk
Calettatore

Kit. Cod KF80.0.210LM

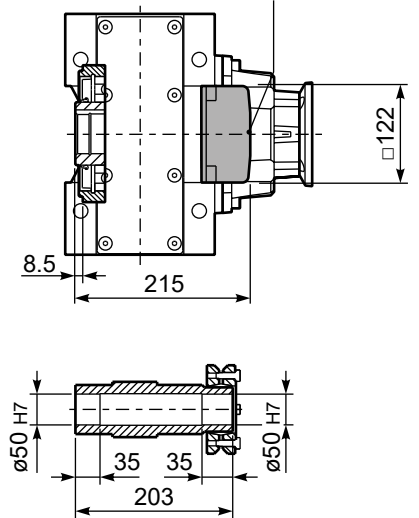

RH83C... Input Shaft
Albero in entrata

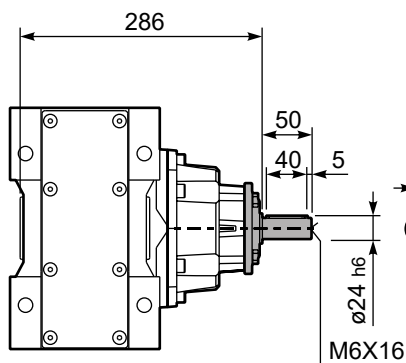

PH83C A... Single output shaft
Albero uscita semplice

Kit. Cod KF80.5.028

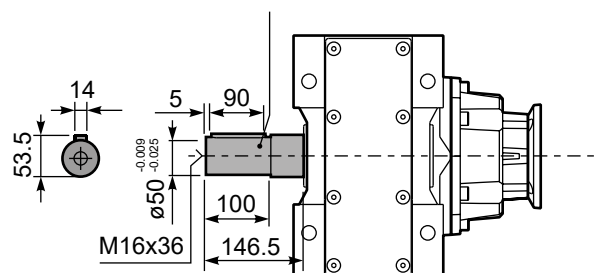

Aluminum and cast iron helical bevel gearboxes

A modular and compact product
Very energy efficient drive

Removable inspection cover

Allows periodic inspection of gearing during routine maintenance

Gears

Hardened and ground gears

Alloy housing

Is vacuum impregnated (MIL-STD 276) for protection and sealing. No secondary finish required but readily accepts paint.

Oil seals

Two oil seals on request

Single-piece aluminum

Combines light weight with high tensile strength. Precision machined for alignment of bearings and gearing

Flange

Fully modular to IEC and Compact integrated motor. NEMA C flange

Cast Iron housing

With high tensile strength. Precision machined for alignment of bearings and gearing

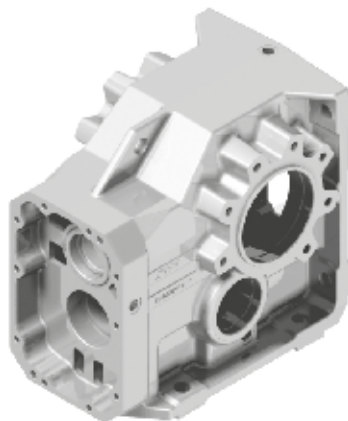

Painting

Cast iron gearboxes are painted RAL 7046

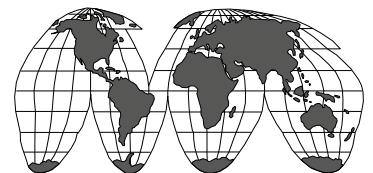

World wide sales network.

Specific type datasheet on page...

On page / A pagina / Auf Seite / À la page / En la página

9-5	9-7	9-9	9-11	9-13	9-15	9-17	9-19	9-21
X22S 50Nm	X32S 90Nm	X33S 100Nm	X42A 150Nm	X43A 160Nm	X52A 250Nm	X53A 250Nm	X62A 410Nm	X63A 410Nm

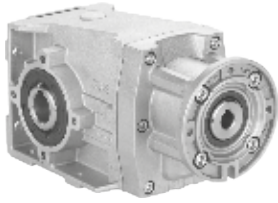

Types / Tipi
Typen / Types
Tipos

On page / A pagina / Auf Seite / À la page / En la página

9-23	9-25	9-27	9-29	9-31	9-33	9-35	9-37	9-39	9-41
X73C 675Nm	X74C 675Nm	X83C 1000Nm	X84C 1000Nm	X93C 1600Nm	X94C 1650Nm	X103 3000Nm	X104 3000Nm	X113 4500Nm	X114 4600Nm

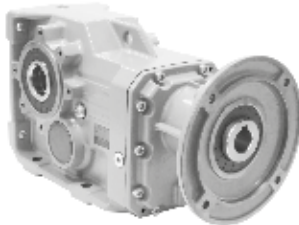

Types / Tipi
Typen / Types
Tipos

On page / A pagina / Auf Seite / À la page / En la página

9-43	9-45	9-47	9-49
113C 675Nm	114C 675Nm	133C 1000Nm	134C 1000Nm

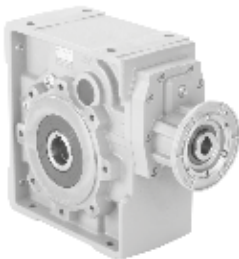

Types / Tipi
Typen / Types
Tipos

On page / A pagina / Auf Seite / À la page / En la página

M-1									
56A 56B	63A 63B	71A 71B	80A 80B	90S 90L	100LA 100LB	112M	132S 132M	160M 160L	180M 180L

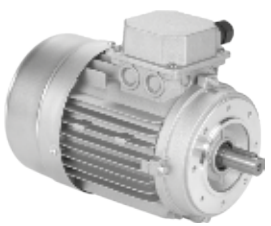



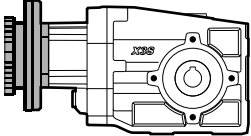
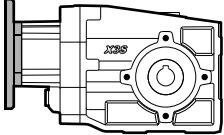
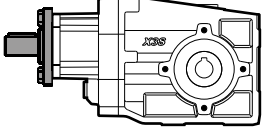
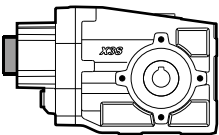
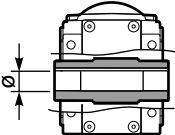
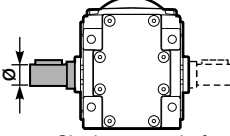
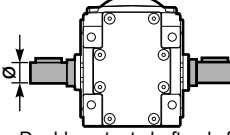
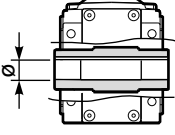
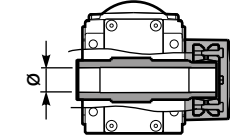





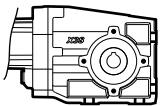
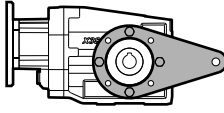
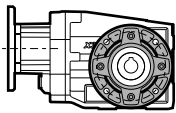
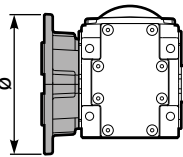

Types / Tipi
Typen / Types
Tipos

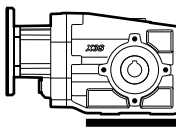
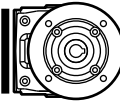
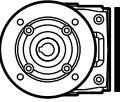
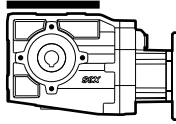
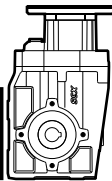
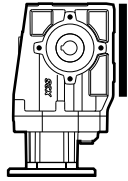
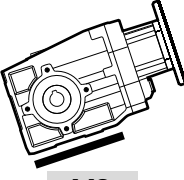
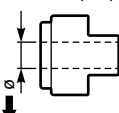
Type - Tipo - Typ Type - Tipo	Size - Grandezza - Größe Taille - Tamaño	Hub - Mozzo corona Hohlwelle Arbre creux Nucleo corona	Rapporto - Ratio Untersetzung Reduction Relacion	Output shaft - Albero uscita Ausgangsflansch Arbre de sortie Brida en salida
M	X22S	C	4.83	-A
<p>Helical-bevel gear Riduttori ortogonali</p>  <p>With IEC motor M</p>  <p>With motor flange P</p>  <p>With male input shaft R</p>  <p>Modular base B</p> <p>Not available for: X93C, X103, X104, X113, X114.</p>	<p>2 Stages Riduzioni Stufen Trains Etapas</p> <p>3 Stages Riduzioni Stufen Trains Etapas</p> <p>Aluminum Alluminio Aluminium Aluminio</p> <p>X22S X32S X42A X52A X62A</p> <p>X33S X43A X53A X63A</p> <p>3 Stages Riduzioni Stufen Trains Etapas</p> <p>4 Stages Riduzioni Stufen Trains Etapas</p> <p>Cast Iron Ghisa Grauguss Fonte Fundicion</p> <p>113C 114C 133C 134C X73C X74C X83C X84C X93C X94C X103 X104 X113 X114</p>	<p>Hollow output shaft C</p>  <p>Single output shaft A</p>  <p>Double output shaft only for 113/4C, 133/4C, X73/4C, X83/4C, X93/4C, X103/4 and X113/4 B</p>  <p>Shrink Disk (only on the DX side) D</p> <p>Only on request for Q.ty A richiesta per quantità</p> <p>Stainless steel hub I</p>  <p>Stainless steel hub Mozzo in acciaio Inox Edelstahlhohlwelle Moyeu en acier Inox Nucleo corona de acero Inox</p> <p>Only on request for Q.ty A richiesta per quantità</p>	<p>See technical data table</p> <p>Vedi tabella dati tecnici.</p> <p>Technisches Datenblatt beachten</p> <p>Voir Tableau données techniques</p> <p>Ver tabla datos técnicos</p>	<p>Hollow output shaft</p> <p>X22S</p> <p>-A ⇨ $\varnothing 18$ -B ⇨ $\varnothing 20$</p> <p>X32S X33S</p> <p>-B ⇨ $\varnothing 20$ -C ⇨ $\varnothing 25$</p> <p>X42A X43A</p> <p>-C ⇨ $\varnothing 25$ -D ⇨ $\varnothing 30$</p> <p>X52A X53A</p> <p>-D ⇨ $\varnothing 30$ -E ⇨ $\varnothing 35$</p> <p>X62A X63A</p> <p>-E ⇨ $\varnothing 35$ -F ⇨ $\varnothing 40$</p> <p>X73/4C X83/4C</p> <p>-F ⇨ $\varnothing 40$ -H ⇨ $\varnothing 45$ 113C 114C</p> <p>-F ⇨ $\varnothing 40$ -G ⇨ $\varnothing 42$ 133C 134C</p> <p>-F ⇨ $\varnothing 40$ -H ⇨ $\varnothing 45$ X93C X94C</p> <p>-H ⇨ $\varnothing 45$ -J ⇨ $\varnothing 50$ X103 X104</p> <p>-K ⇨ $\varnothing 60$ X113 X114</p> <p>-T ⇨ $\varnothing 70$</p> <p>Single and double output shaft</p> <p>-I X22S X32/3S ⇨ $\varnothing 20$ -L X32/3S X42/3A ⇨ $\varnothing 25$ -M X52/3A ⇨ $\varnothing 30$ -N X52/3A X62/3A X73/4A* ⇨ $\varnothing 35$ -V X83/4A 113/4C ⇨ $\varnothing 40^*$ -P 133/4C ⇨ $\varnothing 45^*$ -1 X93/4C ⇨ $\varnothing 50^*$ -3 X103/4 ⇨ $\varnothing 60^*$ -5 X113/4 ⇨ $\varnothing 70^*$</p> <p>* Also available double output shaft</p>  <p>Shrink Disk</p> <p>-U X22S X32/3S ⇨ $\varnothing 20$ -Q X42/3A ⇨ $\varnothing 30$ -R X52/3A ⇨ $\varnothing 35$ -S X62/3A X73/4A X83/4A 113/4C ⇨ $\varnothing 40$ -6 133/4C ⇨ $\varnothing 45$ -7 X93/4C ⇨ $\varnothing 50$ -8 X103/4 ⇨ $\varnothing 65$ -9 X113/4 ⇨ $\varnothing 75$</p>

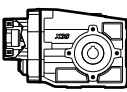

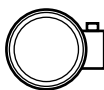
On request we can deliver our products according to the ATEX
 A richiesta possiamo fornire i nostri prodotti secondo le normative ATEX
 Auf Anfrage können wir unsere Produkte den Richtlinien ATEX entsprechend liefern
 Sur demande nos produits peuvent se conformer à la réglementation ATEX
 A pedido, se pueden enviar nuestros productos de acuerdo con las normas ATEX.

Type - Tipo - Typ Type - Tipo	Output flange Flangia di uscita Ausgangs Flansch Bride de sortie Brida en salida	Motor size - Grandezza motore Motor Größe Grandeur moteur - Tamaño motor	Mounting position Posizione montaggio Einbaulage Position de montage Position de montaje	Input bore Foro entrata Eingangshohlwelle Trou d'entree Eje hueco de entrada	Terminal box position Posizione morsettieria Klemmkastenlage Position boîte à bornes Posición caja de bornes	
BR	N	-O	B3	ST		
 <p>FB Forma base Universal</p>  <p>BR Braccio di reazione Reaction arm</p>  <p>-F Flangia uscita output flange</p>	 <p>N Senza flangia Without flange X22S</p> <p>1 ⇒ $\varnothing 120$ X32S X33S</p> <p>1 ⇒ $\varnothing 120$ 2 ⇒ $\varnothing 160$ X42-3A X52-3A X62-3A</p> <p>2 ⇒ $\varnothing 160$ 3 ⇒ $\varnothing 200$ X73C X74C X83C X84C</p> <p>4 ⇒ $\varnothing 250$ 113C 114C X93C X94C</p> <p>C ⇒ $\varnothing 280$ L ⇒ $\varnothing 280$ 133C 134C</p> <p>C ⇒ $\varnothing 320$ X103 X104</p> <p>6 ⇒ $\varnothing 350$ X113 X114</p> <p>7 ⇒ $\varnothing 450$</p>	<p>Flange Flangia </p> <p>B5</p> <p>-A=56 ($\varnothing 120$) -B=63 ($\varnothing 140$) -C=71 ($\varnothing 160$) -D=80 ($\varnothing 200$) -E=90 ($\varnothing 200$) -F=100 ($\varnothing 250$) -G=132 ($\varnothing 300$) -H=160 ($\varnothing 350$) -I=180 ($\varnothing 350$) -L=200 ($\varnothing 400$) CA=225 ($\varnothing 450$)</p> <p>B14</p> <p>-O=56 ($\varnothing 80$) -P=63 ($\varnothing 90$) -Q=71 ($\varnothing 105$) -R=80 ($\varnothing 120$) -T=90 ($\varnothing 140$) -U=100 ($\varnothing 160$) -V=132 ($\varnothing 200$)</p> <p>Brushless</p> <p>BB=50/70-M5 BC=60/75-M5 BD=70/90-M6 BE=80/100-M6 BF=95/115-M8 BG=110/145-M8 BH=130/165-M8</p>	<p>Type R Tipo R </p> <p>X22S X33S X43A</p> <p>-1 ⇒ $\varnothing 14$ X32S X42A X53A X63A X74C X84C 114C 134C</p> <p>-2 ⇒ $\varnothing 19$ X52A X62A 113C 133C X73C X83C X94C</p> <p>-3 ⇒ $\varnothing 24$ X93C X104 X114</p> <p>-4 ⇒ $\varnothing 28$ X103 X113</p> <p>-6 ⇒ $\varnothing 42$</p> <p>Without flange Senza flangia </p> <p>-M ⇒ With coupling</p> <p>X22S X33S X43A</p> <p>-Z ⇒ $\varnothing 9$ (56B5) -0 ⇒ $\varnothing 11$ (63B5) -1 ⇒ $\varnothing 14$ (71B5)</p> <p>X32S X42A X53A X63A X74C X84C 114C 134C</p> <p>-1 ⇒ $\varnothing 14$ (71B5) -2 ⇒ $\varnothing 19$ (80B5) -3 ⇒ $\varnothing 24$ (90B5)</p> <p>X52A X62A 113C 133C X73C X83C X94C</p> <p>-2 ⇒ $\varnothing 19$ (80B5) -3 ⇒ $\varnothing 24$ (90B5) -4 ⇒ $\varnothing 28$ (100B5)</p>	 <p>B3 STANDARD</p>  <p>B6</p>  <p>B7</p>  <p>B8</p>  <p>V5</p>  <p>V6</p>  <p>V8</p>	<p>ST standard bore foro standard</p> <p>COUPLING STANDARD (IEC)</p>  <p>-A = 9mm -B = 11mm -C = 14mm -D = 19mm -E = 24mm -F = 28mm</p> <p>BRUSHLESS *</p>  <p>-2 = 11mm -3 = 14mm -4 = 19mm -5 = 22mm -6 = 24mm</p> <p>-0 Ready for input coupling Predisposto per giunto</p> 	<p>With Type M specify terminal box position Con tipo M specificare posizione morsettieria</p>  <p>A</p>  <p>B STANDARD</p>  <p>C</p>  <p>D</p>

* With reduction bushing where applicable
Con bussola di riduzione dove prevista

POTENZA RICHIESTA / REQUIRED POWER / ERFORDERLICHE LEISTUNG / PUISSANCE NECESSAIRE / POTENCIA NECESARIA

Lifting / sollevamento / hubantriebe / levage / elevación	$P [KW] = \frac{M [Kg] \cdot g [9.81] \cdot v [m / s]}{1000}$
Rotation / rotazione / drehung / rotation / rotação	$P [KW] = \frac{M [Nm] \cdot n [rpm]}{9550}$
Linear movement / traslazione / linearbewegung / translation / translación	$P [KW] = \frac{F [N] \cdot v [m / s]}{1000}$

TORQUE / COPPIA / DREHMOMENT / COUPLE / PAR

	$M [Nm] = \frac{9550 \cdot P[KW]}{n [rpm]}$
	$M [lb in] = \frac{63030 \cdot P[HP]}{n [rpm]}$

RADIAL LOADS / CARICHI RADIALI / RADIALE - UND AXIALLASTEN / CHARGES RADIALES / CARGA RADIAL Y AXIAL

- Radial load generated by external transmissions keyed onto input and/or output shafts.
- Forza radiale generata da organi di trasmissione calettati sugli alberi di ingresso e/o uscita.
- Belastungen der Antriebs- bzw. Abtriebswellen durch von aussen eingebrachte Radiallasten.
- Charge radiale générée par la transmissions calés sur les entrées et / ou des arbres de sortie
- Cargas radiales, generada por transmisiones externas, aplicadas sobre los ejes de entrada y/o salida

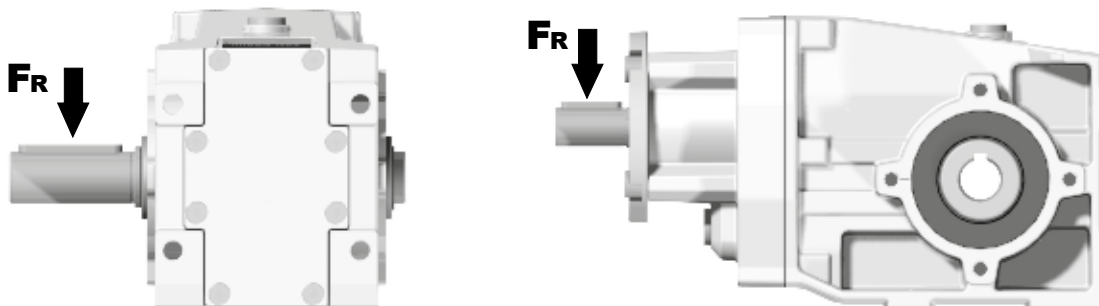

	$F_R [N] = \frac{M [Nm] \cdot 2000}{d [mm]} \cdot f_k$	$F_R [N] = \frac{M [lb in] \cdot 8.9}{d [in]} \cdot f_k$
M	Momento torcente / Output torque / Abtriebsdrehmoment / Couple / Par torsion	
d	Diametro primitivo / Diam. of driving element / Durchmesser der Abtriebseinheit / Diamètre primitif / Diámetro primitivo	
f_k	Coefficiente di trasformazione / Factor / Faktor / Coefficient de transmission / Coeficiente de transmisión 1.15 Ingranaggi / Gearwheels / Zahnrad / Engrenage / Engranaje 1.25 Catena / Chain sprockets / Antriebskette / Chaîne / Cadena 1.75 Cinghia Trapezoidale / Narrow v-belt pulley / Keilriemen / Courroie trap. / Correa trapezoidal 2.50 Cinghia piatta / Flat-belt pulley / Flachzahnriem. / Courroie crantée / Correa plana	

- If your application requires higher radial loads, contact our technical office. Higher load may be possible.
- Nel caso la vostra applicazione richieda carichi radiali superiori consultare il nostro ufficio tecnico, valori maggiori possono essere accettati.
- Wenn Ihre Anwendung höhere Radialbelastungen erfordert, so wenden Sie sich bitte an unser technischen Büro.
- Si votre application demande des charges radiales supérieures, s'adresser à notre bureau technique.
- En el caso en que una aplicación exija una carga radial superior a la especificada en el catálogo, consultar a nuestra oficinas técnica.

How to select a gearbox / Come selezionare un riduttore / Wie wählt man ein Getriebe
Comment sélectionner un réducteur / Cómo seleccionar un reductor

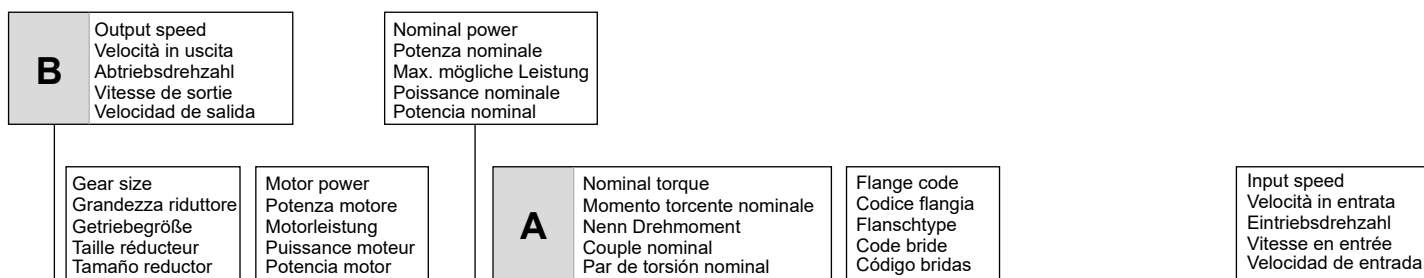

X22S Angletech Gear **50Nm** Rating - Aluminum HELICAL-BEVEL GEARBOXES

QUICK SELECTION / Selezione veloce The dynamic efficiency is **0.96** for all ratios input speed (n_1) = 1400 min⁻¹

Output Speed n_2 [min ⁻¹]	Ratio i	Motor power P_{1M} [kW]	Output torque M_{2M} [Nm]	Service factor f.s.	Nominal power P_{1R} [kW]	Nominal torque M_{2R} [Nm]	Available B5 motor flanges		Available B14 motor flanges			Output Shaft 	Ratios code
							-B	-C	-O	-P	-Q		
289.7	4.83	0.37	11.7	2.6	0.95	30			C	C		289	01
189.2	7.40	0.37	17.9	1.7	0.62	30			C	C		287	02
146.2	9.58	0.37	23.2	1.7	0.64	40			C	C		199	03
127.5	10.98	0.37	26.6	1.7	0.63	45			C	C		179	04



Type of load and starts per hour Tipo di carico e avviamenti per ora		Oper. hours per day Ore di funz. giorn.		
		3 h	10 h	24 h
Continuous or intermittent appl. with start / hour Applicazione cont. o interm. con n.ro operazioni/ora	Uniform / Uniforme	0.8	1	1.25
	Moderate / Moderato	1	1.25	1.5
	Heavy / Forte	1.25	1.5	1.75
Intermittent application with start / hour Applicazione intermittente con n.ro operazioni/ora	Uniform / Uniforme	1	1.25	1.5
	Moderate / Moderato	1.25	1.5	1.75
	Heavy / Forte	1.5	1.75	2.15

D	Motor flange available Flange disponibili Erhältliche Motorflansche Brides disponibles Bridas disponibles	
B)	Mounting with reduction ring Montaggio con boccia di riduzione Reduzierhülsen Montage avec douille de réduction Montaje con casquillo de reducción	
C)	Motor flangeholes position/terminal box position Bohrungsposition am Motorflansch/-sockel Position trous bride/barrette à bornes moteur Posición agujeros brida / base motor	
B)	Available without reduction bushes Disponibile anche senza boccia Auch ohne Reduzierbuchse verfügbar Disponible aussi sans douille de réduction Disponible tambien sin casquillo	

A	Select required torque (according to service factor)	Seleziona la coppia desiderata (comprensiva del fattore di servizio)	Max. Drehmoment in Bezug zum Betriebsfaktor	Sélectionner le couple souhaité (comprenant le facteur de service)	Seleccionar el par deseado (incluyendo el factor de servicio)
B	Select output speed	Seleziona la velocità in uscita	Ausgewählte Abtriebsdrehzahl	Sélectionner la vitesse de sortie	Seleccionar la velocidad de salida
C	On the same line of selected geared motor, you can find the gear ratio	Sulla riga corrispondente alla motorizzazione prescelta si può rilevare il rapporto di riduzione	Auf der gleichen Linie wie die ausgewählte Motorleistung steht auch die Getriebeuntersetzung	Sur la ligne correspondante à la motorisation pré-choisie on peut relever le rapport de réduction	En la línea correspondiente al motor preseleccionado es posible encontrar la relación de reducción
D	Select motor flange available (if requested)	Scegli la flangia disponibile (se richiesta)	Erhältliche Motorflansche (auf Anfrage)	Choisir la bride disponible (si elle est demandée)	Seleccionar la brida disponible (sobre pedido)



QUICK SELECTION / Selezione veloce The dynamic efficiency is **0.96** for all ratios **input speed (n₁) = 1400 min⁻¹**

Output Speed n ₂ [min ⁻¹]	Ratio i	Motor power P _{1M} [kW]	Output torque M _{2M} [Nm]	Service factor f.s.	Nominal power P _{1R} [kW]	Nominal torque M _{2R} [Nm]	Available B5 motor flanges		Available B14 motor flanges			Output Shaft 	Ratios code
							-B	-C	-O	-P	-Q		
290	4.83	0.37	12	2.6	0.95	30			C	C		289	01
189	7.40	0.37	18	1.7	0.62	30			C	C		287	02
146	9.58	0.37	23	1.7	0.64	40			C	C		199	03
128	10.98	0.37	27	1.7	0.63	45			C	C		179	04
107	13.07	0.37	32	1.4	0.53	45			C	C		159	05
95	14.66	0.37	35	1.3	0.47	45			C	C		197	06
89	15.79	0.37	38	1.2	0.44	45			C	C		139	07
83	16.81	0.37	41	1.1	0.41	45			C	C		177	08
70	20.00	0.37	48	1.0	0.37	48			C	C		157	09
64	21.93	0.37	53	0.9	0.35	50			C	C		109	10
58	24.18	0.25	39	1.3	0.32	50			C	C		137	11
48.2	29.04	0.25	47	1.1	0.26	50			C	C		99	12
41.7	33.57	0.18	42	1.2	0.23	50			C	C		107	13
36.2	38.67	0.18	48	1.0	0.20	50			C	C		79	14
31.5	44.44	0.18	55	0.9	0.17	50			C	C		97	15
23.7	59.18	0.12	48	1.0	0.13	50			C	C		77	16
19.9	70.24	0.09	45	1.1	0.11	50			C	C		67	17

Motor Flanges Available Flange Motore Disponibili
 B) Supplied with Reduction Bushing Fornito con Bussola di Riduzione
 B) Available on Request without reduction bushing Disponibile a Richiesta senza Bussola di Riduzione
 C) Motor Flange Holes Position Posizione Fori Flangia Motore

EN Unit **X22S** is supplied with synthetic oil for lifetime lubrication, no maintenance is necessary. See table 1 for lubrication and recommended quantity. In table 2 please see possible radial loads and axial loads on the gearbox.

I Il riduttore **X22S** viene fornito completo di olio sintetico per la lubrificazione permanente e non necessita di alcuna manutenzione. Vedi tab.1 per oli e quantità consigliati. In tab.2 sono presenti i carichi radiali e assiali applicabili al riduttore.

D Das Getriebe **X22S** ist mit synthetischem Öl gefüllt und ist lebensdauergeschmiert. In Tabelle 1 ist die Schmiermenge und das empfohlene Schmiermittel angegeben. In Tabelle 2 sind die zulässigen Radial- und Axialbelastungen des Getriebes aufgeführt.

F Le réducteur **X22S** est fourni complet avec de l'huile synthétique pour la lubrification permanente et ne nécessite aucun entretien. Voir tableau 1 concernant les huiles et les quantités conseillées. Les charges radiales et axiales applicables au réducteur sont précisées dans le tableau 2.

E El reductor tamaño **X22S** se suministra, lubricado de por vida con aceite sintético y no requieren mantenimiento alguna. Ver tabla 1, para cantidades y aceites recomendados. En la tabla 2, se encuentran las cargas radiales y axiales admitidas por el reductor.

Standard supplied	For these mounting position specify in the order or add oil Per queste posizioni specificare in fase d'ordine o aggiungere olio					
0.25 LT	0.25 LT	0.25 LT	0.25 LT	0.43 LT	0.31 LT	Ask
SHELL Omala S4 WE 320				ENI Telium VSF 320		

For all details on lubrication and plugs check our website **tab. 1**
Per maggiori dettagli su lubrificazione e tappi olio vedi il nostro sito web

RADIAL AND AXIAL LOADS

Output shaft

Albero di uscita

$$F_{eq} = F_R \cdot \frac{101}{X+82}$$

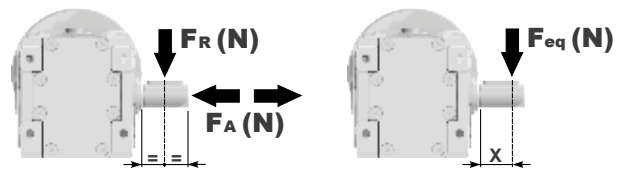

n ₂ [min ⁻¹]	FA	FR	n ₂ [min ⁻¹]	FA	FR	n ₂ [min ⁻¹]	FA	FR
400	360	1800	100	440	2200	25	440	2200
250	380	1900	75	440	2200	15	440	2200
150	420	2100	50	440	2200			

FR On request taper roller bearings to increase radial loads.
A richiesta cuscinetti a rulli conici per aumentare i carichi radiali.

Input shaft

albero in entrata

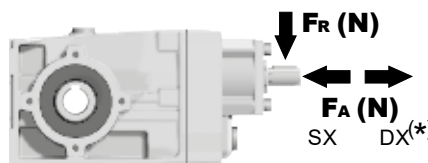

n ₁ [min ⁻¹]	FA	FR
1400	140	700
900	160	800
500	190	950

*Strong axial loads in the DX direction are not allowed.
Non sono consentiti forti carichi assiali con direzione DX

tab. 2

PX22SC... Basic Gearbox
Riduttore base

Gearbox weight
peso riduttore **3.70 kg**

M. flanges	Kit code	øF	A
63B5	K050.4.041	138	154.5
71B5	K050.4.042	160	152
56B14	KC40.4.049	80	152
63B14	K050.4.047	90	154.5
71B14	K050.4.045	105	152

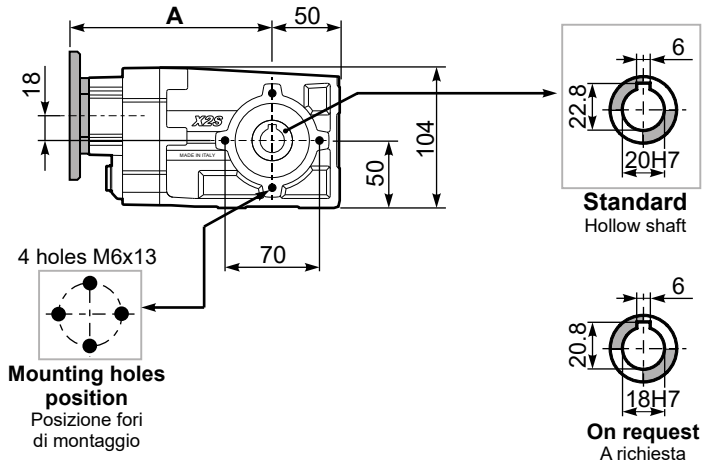
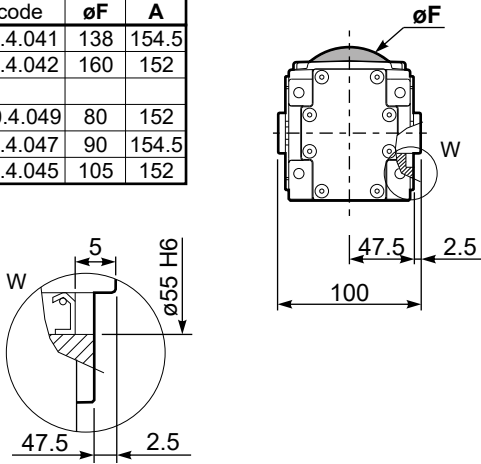

PX22S...**FB**.. Feet
Piedini

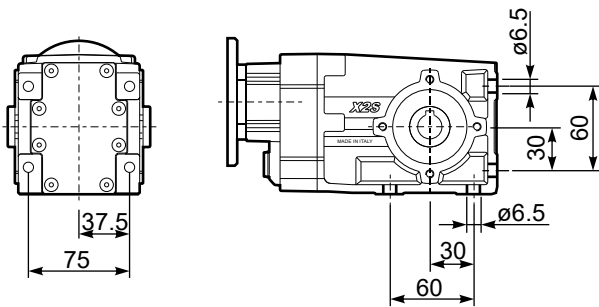

PX22S...**-F1**.. Output flange
Flangia uscita

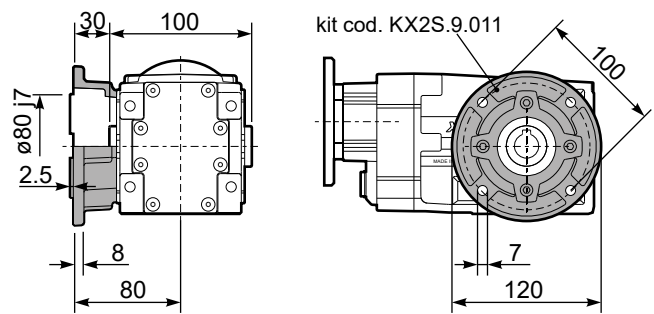

PX22S**A**.. Single output shaft
Albero semplice in uscita

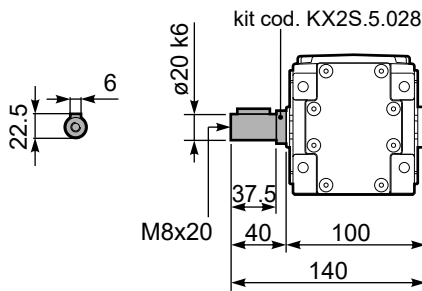

PX22S...**BR**.. Reaction Arm
Braccio di reazione

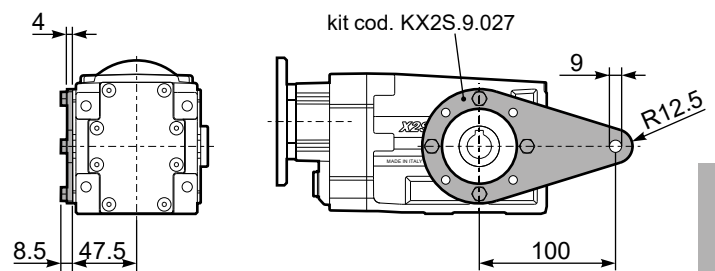

RX22S.. Input shaft
Albero in entrata

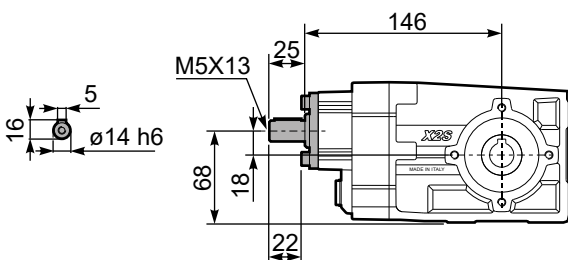



QUICK SELECTION / Selezione veloce The dynamic efficiency is **0.96** for all ratios **input speed (n₁) = 1400 min⁻¹**

Output Speed n ₂ [min ⁻¹]	Ratio i	Motor power P _{1M} [kW]	Output torque M _{2M} [Nm]	Service factor f.s.	Nominal power P _{1R} [kW]	Nominal torque M _{2R} [Nm]	Available B5 motor flanges				Available B14 motor flanges			Output Shaft 	Ratios code		
							-B	-C	-D	-E	-Q	-R	-T				
							63	71	80	90	71	80	90				
191	7.33	1.5	72	1.0	1.5	70	B				C	C		289	standard ø20	01	
125	11.22	1.1	80	1.1	1.2	85	B				C	C		287		02	
106	13.26	1.1	95	0.9	0.98	85	B				C	C		199		03	
91	15.37	1.1	110	0.8	0.89	90	B				C	C		179		04	
78	18.04	0.75	89	1.0	0.76	90	B				C	C		159		05	
69	20.30	0.75	100	0.9	0.68	90	B				C	C		197		06	
65	21.54	0.75	106	0.9	0.64	90	B				C	C		139		07	
59	23.53	0.55	85	1.1	0.58	90	B				C	C		177		08	
51	27.62	0.55	100	0.9	0.50	90	B				C	C		157		09	
47.6	29.40	0.55	106	0.8	0.47	90	B				C	C		109		On request	10
42.5	32.97	0.37	80	1.1	0.42	90	B				C	C		137		11	
36.5	38.37	0.37	93	1.0	0.36	90	B				C	C		99		12	
31.1	45.00	0.25	73	1.2	0.31	90	B				C	C		107		13	
27.6	50.67	0.25	83	1.1	0.27	90	B				C	C		79		14	
23.8	58.73	0.18	73	1.2	0.23	90	B				C	C		97		15	
18.1	77.55	0.18	97	0.9	0.18	90	B				C	C		77		16	

Motor Flanges Available Flange Motore Disponibili **B) Supplied with Reduction Bushing** Fornito con Bussola di Riduzione **B) Available on Request without reduction bushing** Disponibile a Richiesta senza Bussola di Riduzione **C) Motor Flange Holes Position** Posizione Fori Flangia Motore

EN Unit **X32S** is supplied with synthetic oil for lifetime lubrication, no maintenance is necessary. See table 1 for lubrication and recommended quantity. In table 2 please see possible radial loads and axial loads on the gearbox.

I Il riduttore **X32S** viene fornito completo di olio sintetico per la lubrificazione permanente e non necessita di alcuna manutenzione. Vedi tab.1 per oli e quantità consigliati. In tab.2 sono presenti i carichi radiali e assiali applicabili al riduttore.

D Das Getriebe **X32S** ist mit synthetischem Öl gefüllt und ist lebensdauer geschmiert. In Tabelle 1 ist die Schmiermenge und das empfohlene Schmiermittel angegeben. In Tabelle 2 sind die zulässigen Radial- und Axialbelastungen des Getriebes aufgeführt.

F Le réducteur **X32S** est fourni complet avec de l'huile synthétique pour la lubrification permanente et ne nécessite aucun entretien. Voir tableau 1 concernant les huiles et les quantités conseillées. Les charges radiales et axiales applicables au réducteur sont précisées dans le tableau 2.

E El reductor tamaño **X32S** se suministra, lubricado de por vida con aceite sintético y no requieren mantenimiento alguna. Ver tabla 1, para cantidades y aceites recomendados. En la tabla 2, se encuentran las cargas radiales y axiales admitidas por el reductor.

Standard supplied	For these mounting position specify in the order or add oil Per queste posizioni specificare in fase d'ordine o aggiungere olio						
0.40 LT	0.60 LT	0.40 LT	0.60 LT	0.85 LT	0.60 LT	Ask	
SHELL Omala S4 WE 320				ENI Telium VSF 320			

For all details on lubrication and plugs check our website **tab. 1**
Per maggiori dettagli su lubrificazione e tappi olio vedi il nostro sito web

RADIAL AND AXIAL LOADS

Output shaft
Albero di uscita

$$F_{eq} = F_R \cdot \frac{115.5}{X+96.5}$$

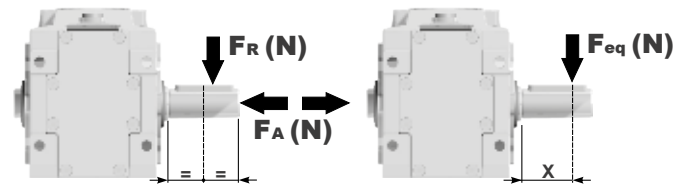

n ₂ [min ⁻¹]	FA	FR	n ₂ [min ⁻¹]	FA	FR	n ₂ [min ⁻¹]	FA	FR
250	400	2000	75	560	2800	15	560	2800
150	450	2250	50	560	2800			
100	500	2500	25	560	2800			

F_R On request taper roller bearings to increase radial loads.
A richiesta cuscinetti a rulli conici per aumentare i carichi radiali.

Input shaft
albero in entrata

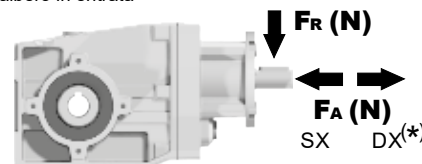

n ₁ [min ⁻¹]	FA	FR
1400	240	1200
900	280	1400
500	340	1700

***Strong axial loads in the DX direction are not allowed.**
Non sono consentiti forti carichi assiali con direzione DX

tab. 2

PX32SC... Basic Gearbox
Riduttore base

Gearbox weight
peso riduttore **6.30 kg**

M. flanges	Kit code	øF	A
63B5	K063.4.041	140	184
71B5	K063.4.042	160	182
80/90B5	K063.4.043	200	184
71B14	K063.4.047	105	182
80B14	K063.4.046	120	184
90B14	K063.4.041	140	184

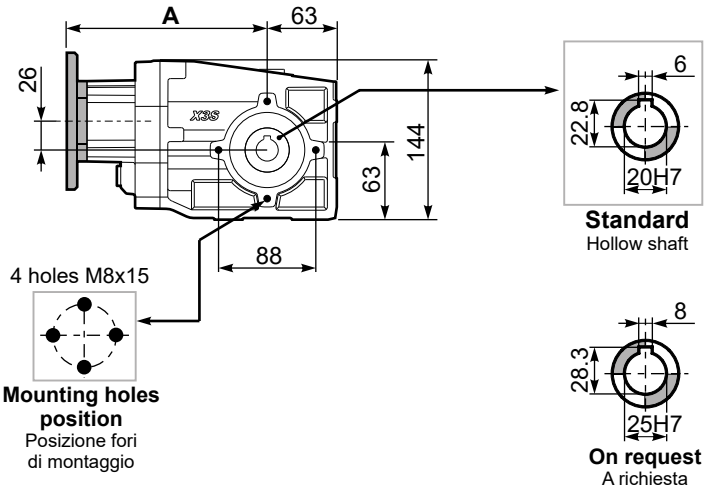
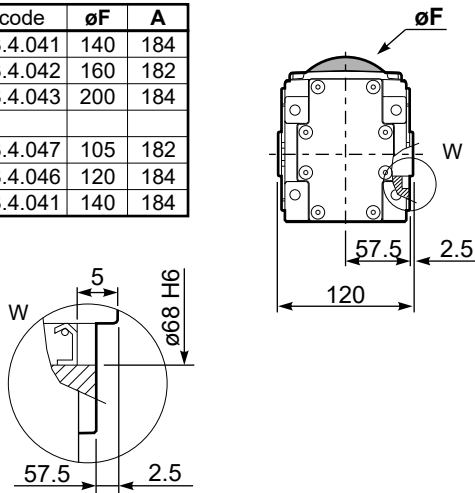

PX32S...FB.. Feet
Piedini

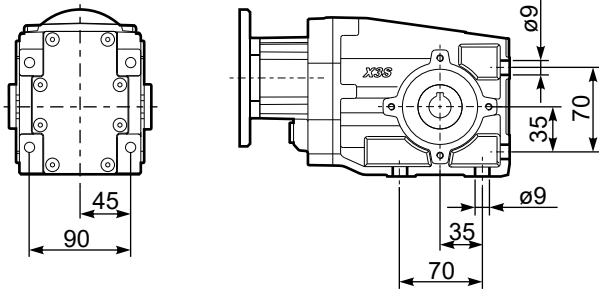

PX32S...-F1.. Output flange
Flangia uscita

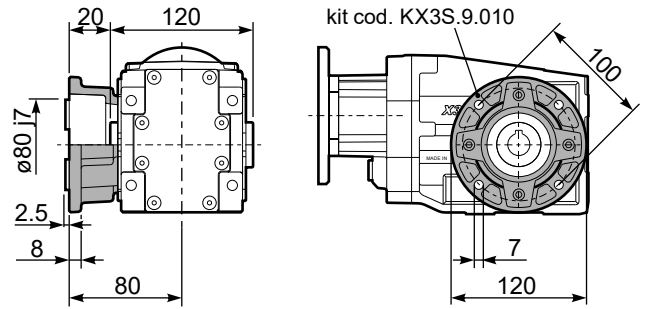

PX32S...-F2.. Output flange
Flangia uscita

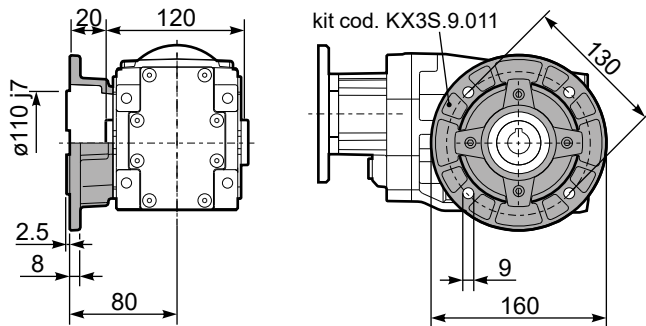

PX32S...BR.. Reaction Arm
Braccio di reazione

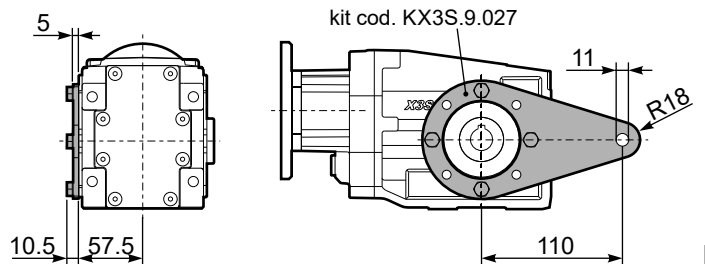

RX32S... Input shaft
Albero in entrata

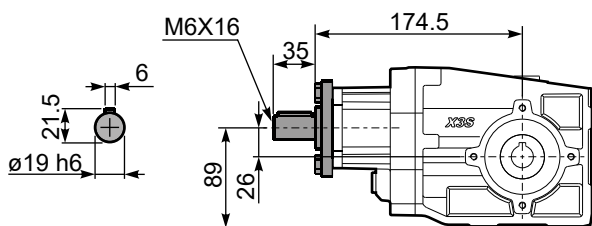

PX32SA.. Single output shaft
Albero semplice in uscita

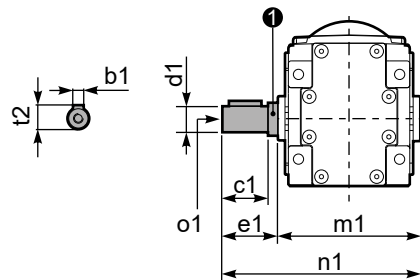

d1	b1	c1	e1	m1	n1	t2	o1	1 kit code
ø20 k6	6	37.5	40	120	160	22.5	M8x20	KX2S.5.028
ø25 ^{-0.005} _{-0.020}	8	60	63.2	126.8	190	28	M8x20	K063.5.028



QUICK SELECTION / Selezione veloce The dynamic efficiency is 0.94 for all ratios input speed (n₁) = 1400 min⁻¹

Output Speed n ₂ [min ⁻¹]	Ratio i	Motor power P _{1M} [kW]	Output torque M _{2M} [Nm]	Service factor f.s.	Nominal power P _{1R} [kW]	Nominal torque M _{2R} [Nm]	Available B5 motor flanges		Available B14 motor flanges			Output Shaft 	Ratios code
							-B	-C	-O	-P	-Q		
							63	71	56	63	71		
38.7	36.17	0.37	86	1.2	0.43	100			C	C		17179	02
31.7	44.21	0.37	105	1.0	0.35	100			C	C		19139	03
27.6	50.68	0.25	81	1.2	0.31	100			C	C		17139	04
25.3	55.36	0.25	89	1.1	0.28	100			C	C		17177	05
23.2	60.31	0.25	96	1.0	0.26	100			C	C		15139	06
21.2	65.88	0.25	105	0.9	0.24	100			C	C		15177	07
19.4	72.25	0.18	88	1.1	0.22	100			C	C		10179	08
17.6	79.64	0.18	97	1.0	0.20	100			C	C	standard ø20	13177	09
15.2	92.31	0.18	113	0.9	0.17	100			C	C		15137	10
14.6	95.65	0.18	117	0.9	0.16	100			C	C		9179	11
13.8	101.23	0.12	80	1.2	0.15	100			C	C	ø25	10139	12
11.0	127.37	0.12	101	1.0	0.12	100			C	C	On request	7179	13
9.3	151.16	0.09	95	1.0	0.10	100			C	C		6179	14
7.8	178.46	0.09	113	0.9	0.09	100			C	C		7139	15
6.6	211.79	0.06	88	1.1	0.07	100			C	C		6139	16
6.1	231.37	0.06	96	1.0	0.07	100			C	C		6177	17
5.1	273.16	0.06	113	0.9	0.06	100			C	C		7137	18
4.3	324.18	0.06	134	0.7	0.05	100			C	C		6137	19

Motor Flanges Available Flange Motore Disponibili
B) Supplied with Reduction Bushing Fornito con Bussola di Riduzione
B) Available on Request without reduction bushing Disponibile a Richiesta senza Bussola di Riduzione
C) Motor Flange Holes Position Posizione Fori Flangia Motore

EN Unit **X33S** is supplied with synthetic oil for lifetime lubrication, no maintenance is necessary. See table 1 for lubrication and recommended quantity. In table 2 please see possible radial loads and axial loads on the gearbox.

I Il riduttore **X33S** viene fornito completo di olio sintetico per la lubrificazione permanente e non necessita di alcuna manutenzione. Vedi tab.1 per oli e quantità consigliati. In tab.2 sono presenti i carichi radiali e assiali applicabili al riduttore.

D Das Getriebe **X33S** ist mit synthetischem Öl gefüllt und ist lebensdauergeschmiert. In Tabelle 1 ist die Schmiermenge und das empfohlene Schmiermittel angegeben. In Tabelle 2 sind die zulässigen Radial - und Axialbelastungen des Getriebes aufgeführt.

F Le réducteur **X33S** est fourni complet avec de l'huile synthétique pour la lubrification permanente et ne nécessite aucun entretien. Voir tableau 1 concernant les huiles et les quantités conseillées. Les charges radiales et axiales applicables au réducteur sont précisées dans le tableau 2.

E El reductor tamaño **X33S** se suministra, lubricado de por vida con aceite sintético y no requieren mantenimiento alguna. Ver tabla 1, para cantidades y aceites recomendados. En la tabla 2, se encuentran las cargas radiales y axiales admitidas por el reductor.

Standard supplied	For these mounting position specify in the order or add oil Per queste posizioni specificare in fase d'ordine o aggiungere olio					
0.70 LT	0.65 LT	0.40 LT	0.65 LT	0.95 LT	0.65 LT	Ask
SHELL Omala S4 WE 320				ENI Telium VSF 320		

For all details on lubrication and plugs check our website **tab. 1**
Per maggiori dettagli su lubrificazione e tappi olio vedi il nostro sito web

RADIAL AND AXIAL LOADS

Output shaft

Albero di uscita

$$F_{eq} = F_R \cdot \frac{115.5}{X+96.5}$$

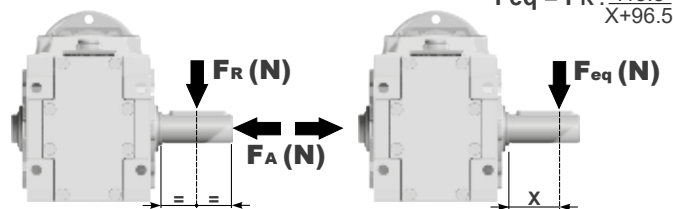

n ₂ [min ⁻¹]	FA	FR	n ₂ [min ⁻¹]	FA	FR	n ₂ [min ⁻¹]	FA	FR
250	400	2000	75	560	2800	15	560	2800
150	450	2250	50	560	2800			
100	500	2500	25	560	2800			

FR On request taper roller bearings to increase radial loads.
A richiesta cuscinetti a rulli conici per aumentare i carichi radiali.

Input shaft

albero in entrata

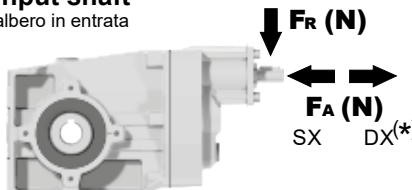

n ₁ [min ⁻¹]	FA	FR
1400	140	700
900	160	800
500	190	950

*Strong axial loads in the DX direction are not allowed.
Non sono consentiti forti carichi assiali con direzione DX

tab. 2

PX33SC... Basic Gearbox
Riduttore base

Gearbox weight
peso riduttore **6.55 kg**

M. flanges	Kit code	øF	A
63B5	K050.4.041	138	189.5
71B5	K050.4.042	160	187
56B14	KC40.4.049	80	187
63B14	K050.4.047	90	189.5
71B14	K050.4.045	105	187

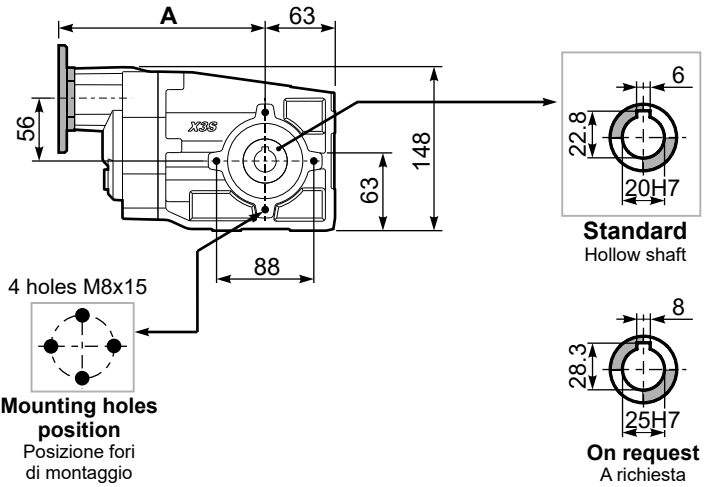
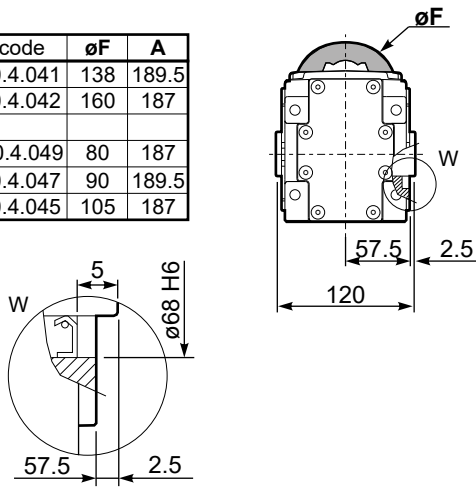

4 holes M8x15
Mounting holes position
Posizione fori di montaggio

PX33S...FB.. Feet
Piedini

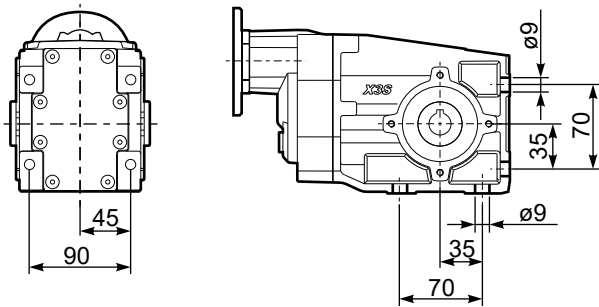

PX33S...-F1.. Output flange
Flangia uscita

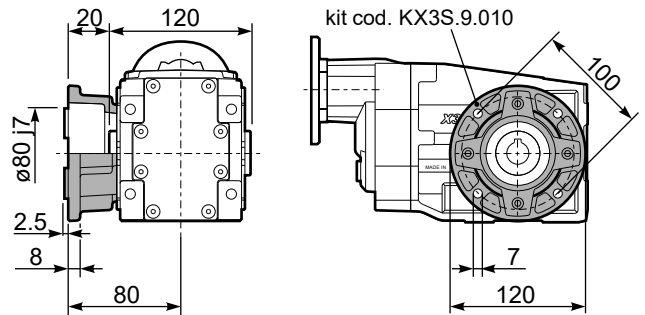

PX33S...-F2.. Output flange
Flangia uscita

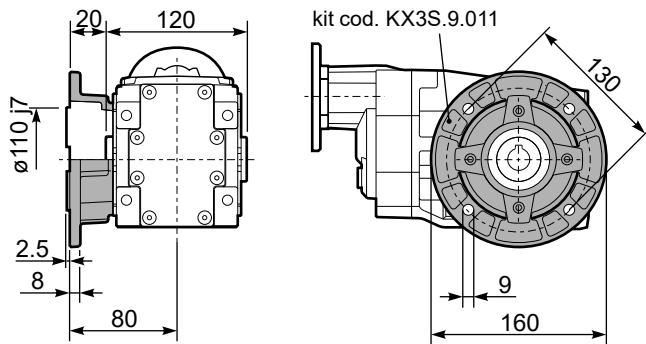

PX33S...BR.. Reaction Arm
Braccio di reazione

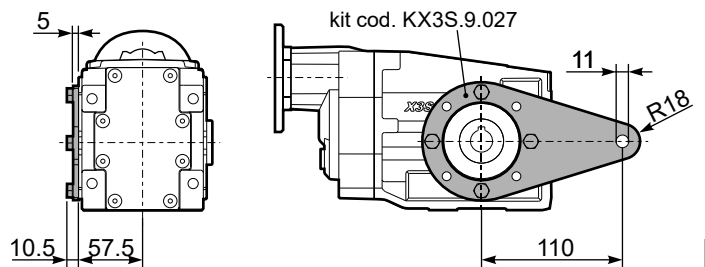

RX33S... Input shaft
Albero in entrata

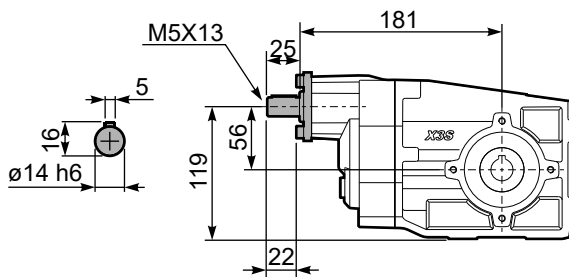

PX33SA.. Single output shaft
Albero semplice in uscita

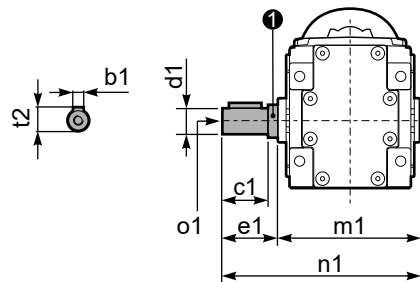

d1	b1	c1	e1	m1	n1	t2	o1	1 kit code
ø20 k6	6	37.5	40	120	160	22.5	M8x20	KX2S.5.028
ø25 ^{-0.005} _{-0.020}	8	60	63.2	126.8	190	28	M8x20	K063.5.028



QUICK SELECTION / Selezione veloce The dynamic efficiency is **0.96** for all ratios **input speed (n₁) = 1400 min⁻¹**

Output Speed n ₂ [min ⁻¹]	Ratio i	Motor power P _{1M} [kW]	Output torque M _{2M} [Nm]	Service factor f.s.	Nominal power P _{1R} [kW]	Nominal torque M _{2R} [Nm]	Available B5 motor flanges					Available B14 motor flanges				Output Shaft 	Ratios code
							-B	-C	-D	-E	-F	-Q	-R	-T	-U		
							63	71	80	90	100	112	71	80	90		
192	7.29	2.2	104	0.9	2.0	95	B					C	C			2811	01
125	11.20	2.2	159	0.9	2.0	150	B					C	C			288	02
106	13.18	1.5	129	1.2	1.7	150	B					C	C			1911	03
92	15.27	1.1	109	1.4	1.5	150	B					C	C			1711	04
78	17.93	1.1	128	1.2	1.3	150	B					C	C			1511	05
69	20.25	1.1	145	1.0	1.1	150	B					C	C			198	06
65	21.40	1.1	153	1.0	1.1	150	B					C	C			1311	07
60	23.47	0.75	115	1.3	0.98	150	B					C	C			178	08
51	27.55	0.75	135	1.1	0.83	150	B					C	C			158	09
47.9	29.21	0.75	143	1.0	0.78	150	B					C	C			1011	10
42.6	32.88	0.75	161	0.9	0.70	150	B					C	C			138	11
36.7	38.12	0.55	138	1.1	0.60	150	B					C	C			911	12
31.2	44.89	0.55	163	0.9	0.51	150	B					C	C			108	13
27.8	50.34	0.37	122	1.1	0.40	131	B					C	C			711	14
23.9	58.58	0.37	142	1.1	0.39	150	B					C	C			98	15
18.1	77.36	0.25	126	1.2	0.30	150	B					C	C			78	16

Motor Flanges Available Flange Motore Disponibili **B) Supplied with Reduction Bushing** Fornito con Bussola di Riduzione **B) Available on Request without reduction bushing** Disponibile a Richiesta senza Bussola di Riduzione **C) Motor Flange Holes Position** Posizione Fori Flangia Motore

EN Unit **X42A** is supplied with synthetic oil for lifetime lubrication, no maintenance is necessary. See table 1 for lubrication and recommended quantity. In table 2 please see possible radial loads and axial loads on the gearbox.

I Il riduttore **X42A** viene fornito completo di olio sintetico per la lubrificazione permanente e non necessita di alcuna manutenzione. Vedi tab.1 per oli e quantità consigliati. In tab.2 sono presenti i carichi radiali e assiali applicabili al riduttore.

D Das Getriebe **X42A** ist mit synthetischem Öl gefüllt und ist lebensdauergeschmiert. In Tabelle 1 ist die Schmiermenge und das empfohlene Schmiermittel angegeben. In Tabelle 2 sind die zulässigen Radial- und Axialbelastungen des Getriebes aufgeführt.

F Le réducteur **X42A** est fourni complet avec de l'huile synthétique pour la lubrification permanente et ne nécessite aucun entretien. Voir tableau 1 concernant les huiles et les quantités conseillées. Les charges radiales et axiales applicables au réducteur sont précisées dans le tableau 2.

E El reductor tamaño **X42A** se suministra, lubricado de por vida con aceite sintético y no requieren mantenimiento alguna. Ver tabla 1, para cantidades y aceites recomendados. En la tabla 2, se encuentran las cargas radiales y axiales admitidas por el reductor.

Standard supplied	For these mounting position specify in the order or add oil Per queste posizioni specificare in fase d'ordine o aggiungere olio					
B3	B6	B7	B8	V5	V6	V8
0.60 LT	0.75 LT	0.50 LT	0.70 LT	1.10 LT	0.60 LT	Ask
SHELL Omala S4 WE 320				ENI Telium VSF 320		

For all details on lubrication and plugs check our website **tab. 1**
Per maggiori dettagli su lubrificazione e tappi olio vedi il nostro sito web

RADIAL AND AXIAL LOADS

Output shaft

Albero di uscita

$$F_{eq} = FR \cdot \frac{123}{X+97}$$

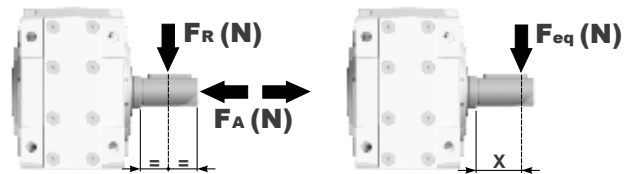

n ₂ [min ⁻¹]	FA	FR	n ₂ [min ⁻¹]	FA	FR	n ₂ [min ⁻¹]	FA	FR
250	500	2500	75	800	4000	15	960	4800
150	600	3000	50	960	4800			
100	700	3500	25	960	4800			

FR On request taper roller bearings to increase radial loads.
A richiesta cuscinetti a rulli conici per aumentare i carichi radiali.

Input shaft

albero in entrata

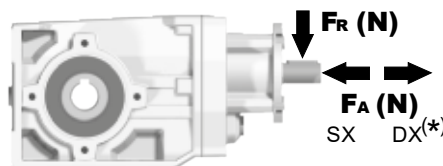

n ₁ [min ⁻¹]	FA	FR
1400	240	1200
900	280	1400
500	340	1700

***Strong axial loads in the DX direction are not allowed.**
Non sono consentiti forti carichi assiali con direzione DX

tab. 2

PX42AC... Basic Gearbox
Riduttore base

Gearbox weight
peso riduttore **7.82 kg**

M. flanges	Kit code	øF	A
63B5	K063.4.041	140	199.5
71B5	K063.4.042	160	197.5
80/90B5	K063.4.043	200	199.5
100/112B5	KC40.4.043	250	214.3
71B14	K063.4.047	105	197.5
80B14	K063.4.046	120	199.5
90B14	K063.4.041	140	199.5
100/112B14	KC40.4.041	160	214.5

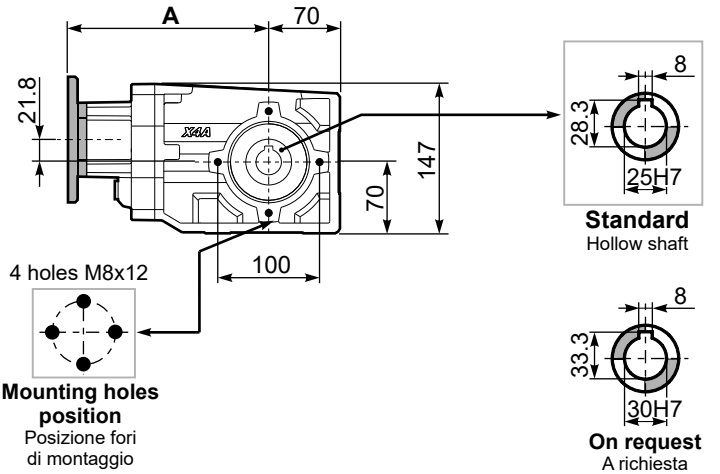
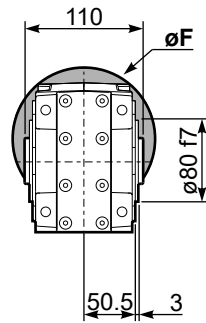

PX42A...FB.. Feet
Piedini

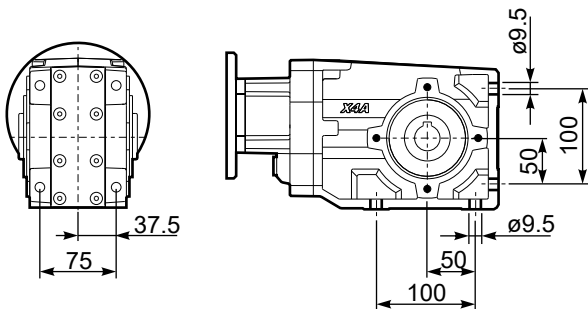

PX42A...-F2.. Output flange
Flangia uscita

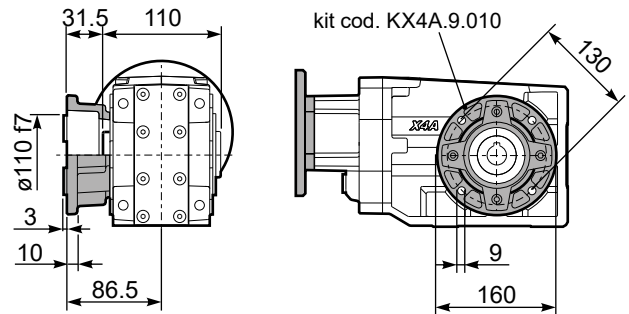

PX42A...-F3.. Output flange
Flangia uscita

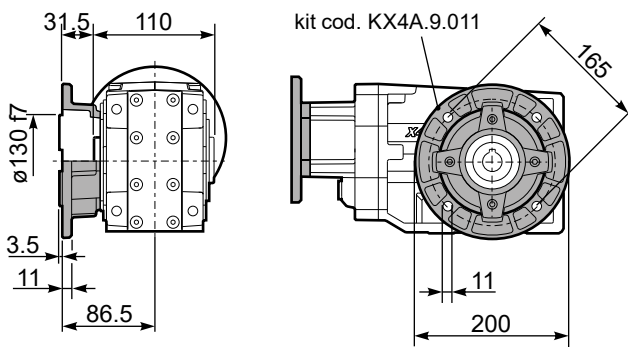

PX42A...BR.. Reaction Arm
Braccio di reazione

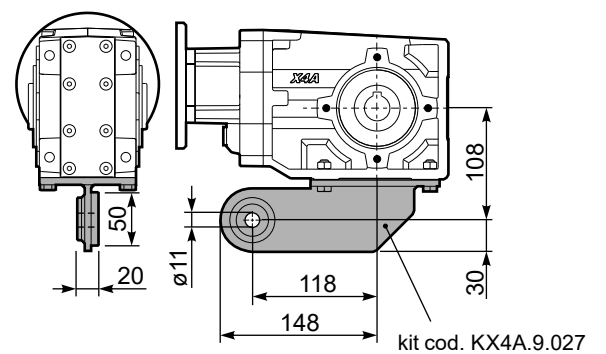

RX42A... Input shaft
Albero in entrata

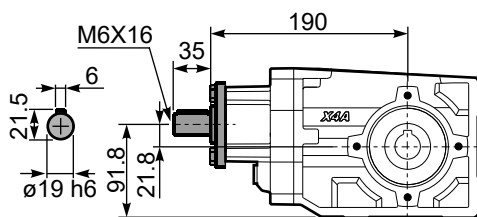

PX42AA.. Single output shaft
Albero semplice in uscita

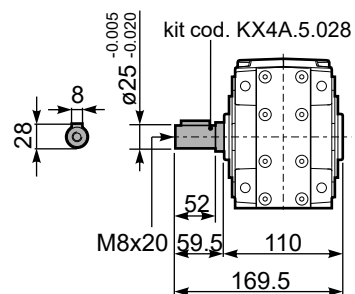



QUICK SELECTION / Selezione veloce The dynamic efficiency is **0.94** for all ratios **input speed (n₁) = 1400 min⁻¹**

Output Speed n ₂ [min ⁻¹]	Ratio i	Motor power P _{1M} [kW]	Output torque M _{2M} [Nm]	Service factor f.s.	Nominal power P _{1R} [kW]	Nominal torque M _{2R} [Nm]	Available B5 motor flanges		Available B14 motor flanges			Output Shaft 	Ratios code
							-B	-C	-O	-P	-Q		
							63	71	56	63	71		
27.8	50.35	0.37	119	1.3	0.46	150			C	C		171311	01
25.4	55.22	0.37	131	1.1	0.42	150			C	C		17178	02
23.4	59.92	0.37	142	1.1	0.39	150			C	C		151311	03
21.3	65.72	0.37	156	1.0	0.36	150			C	C		15178	04
19.5	71.78	0.25	115	1.3	0.33	150			C	C		101711	05
17.6	79.44	0.25	127	1.2	0.29	150			C	C		13178	06
15.2	92.08	0.25	147	1.0	0.25	150			C	C		15138	07
14.7	95.03	0.25	152	1.0	0.25	150			C	C		91711	08
11.1	126.55	0.18	155	1.0	0.20	160			C	C		71711	09
10.5	133.15	0.18	163	1.0	0.19	160			C	C		91311	10
9.3	150.18	0.12	119	1.3	0.17	160			C	C		61711	11
7.9	177.30	0.12	140	1.1	0.14	160			C	C		71311	12
6.7	210.42	0.09	133	1.2	0.12	160			C	C		61311	13
6.1	230.79	0.09	146	1.1	0.11	160			C	C		6178	14
5.1	272.47	0.06	113	1.4	0.09	160			C	C		7138	15
4.3	323.37	0.06	134	1.2	0.08	160			C	C		6138	16

Motor Flanges Available Flange Motore Disponibili
B) Supplied with Reduction Bushing Fornito con Bussola di Riduzione
B) Available on Request without reduction bushing Disponibile a Richiesta senza Bussola di Riduzione
C) Motor Flange Holes Position Posizione Fori Flangia Motore

EN Unit **X43A** is supplied with synthetic oil for lifetime lubrication, no maintenance is necessary. See table 1 for lubrication and recommended quantity. In table 2 please see possible radial loads and axial loads on the gearbox.

I Il riduttore **X43A** viene fornito completo di olio sintetico per la lubrificazione permanente e non necessita di alcuna manutenzione. Vedi tab.1 per oli e quantità consigliati. In tab.2 sono presenti i carichi radiali e assiali applicabili al riduttore.

D Das Getriebe **X43A** ist mit synthetischem Öl gefüllt und ist lebensdauergeschmiert. In Tabelle 1 ist die Schmiermenge und das empfohlene Schmiermittel angegeben. In Tabelle 2 sind die zulässigen Radial- und Axialbelastungen des Getriebes aufgeführt.

F Le réducteur **X43A** est fourni complet avec de l'huile synthétique pour la lubrification permanente et ne nécessite aucun entretien. Voir tableau 1 concernant les huiles et les quantités conseillées. Les charges radiales et axiales applicables au réducteur sont précisées dans le tableau 2.

E El reductor tamaño **X43A** se suministra, lubricado de por vida con aceite sintético y no requieren mantenimiento alguna. Ver tabla 1, para cantidades y aceites recomendados. En la tabla 2, se encuentran las cargas radiales y axiales admitidas por el reductor.

Standard supplied	For these mounting position specify in the order or add oil Per queste posizioni specificare in fase d'ordine o aggiungere olio					
B3	B6	B7	B8	V5	V6	V8
0.80 LT	0.80 LT	0.60 LT	0.80 LT	1.20 LT	0.70 LT	Ask
SHELL Omala S4 WE 320			ENI Telium VSF 320			

For all details on lubrication and plugs check our website **tab. 1**
Per maggiori dettagli su lubrificazione e tappi olio vedi il nostro sito web

RADIAL AND AXIAL LOADS

Output shaft

Albero di uscita

$$F_{eq} = F_R \cdot \frac{123}{X+97}$$

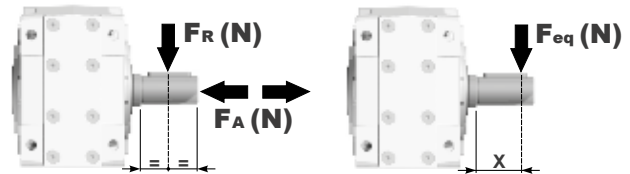

n ₂ [min ⁻¹]	FA	FR	n ₂ [min ⁻¹]	FA	FR	n ₂ [min ⁻¹]	FA	FR
250	500	2500	75	800	4000	15	960	4800
150	600	3000	50	960	4800			
100	700	3500	25	960	4800			

FR On request taper roller bearings to increase radial loads.
A richiesta cuscinetti a rulli conici per aumentare i carichi radiali.

Input shaft

albero in entrata

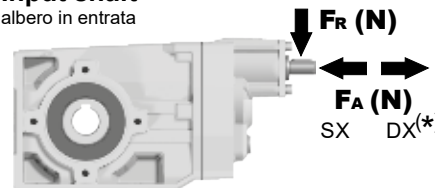

n ₁ [min ⁻¹]	FA [N]	FR [N]
1400	140	700
900	160	800
500	190	950

***Strong axial loads in the DX direction are not allowed.**
Non sono consentiti forti carichi assiali con direzione DX

PX43AC... Basic Gearbox
Riduttore base

Gearbox weight
peso riduttore **7.93 kg**

M. flanges	Kit code	øF	A
63B5	K050.4.041	138	205
71B5	K050.4.042	160	202.5
56B14	KC40.4.049	80	202.5
63B14	K050.4.047	90	205
71B14	K050.4.045	105	202.5

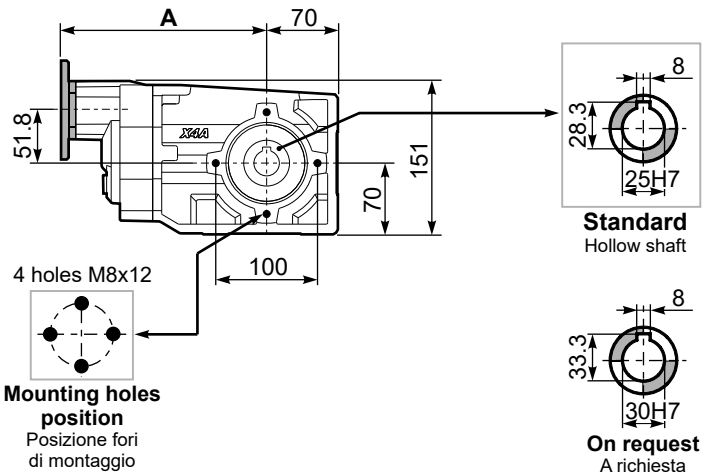
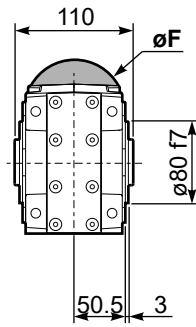

PX43A...FB.. Feet
Piedini

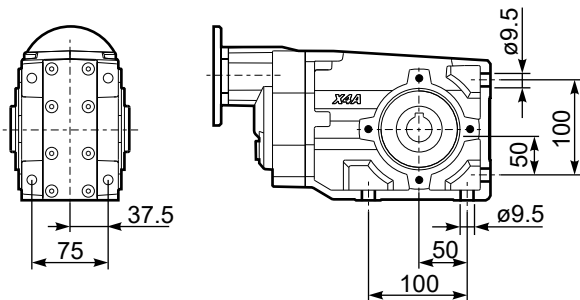

PX43A...-F2.. Output flange
Flangia uscita

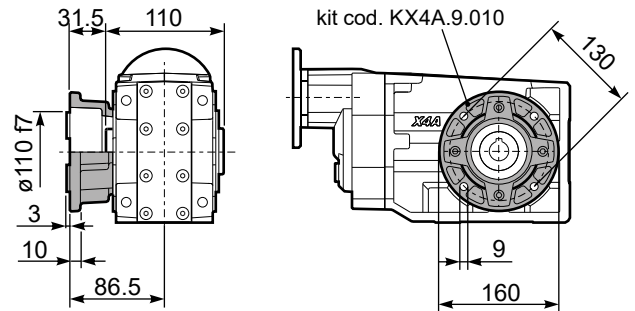

PX43A...-F3.. Output flange
Flangia uscita

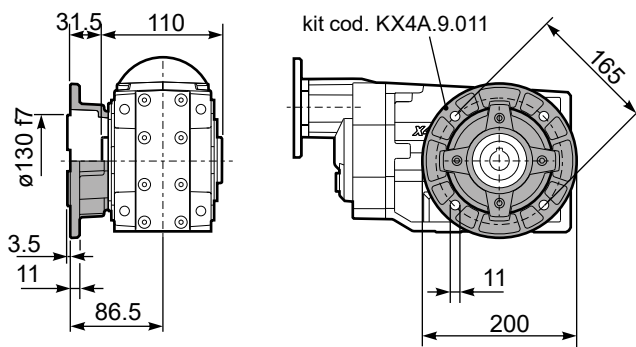

PX43A...BR.. Reaction Arm
Braccio di reazione

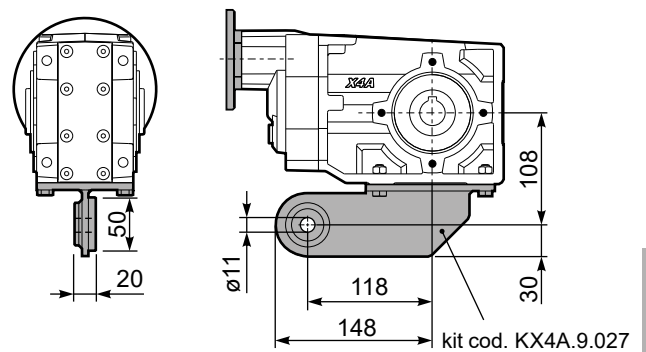

RX43A... Input shaft
Albero in entrata

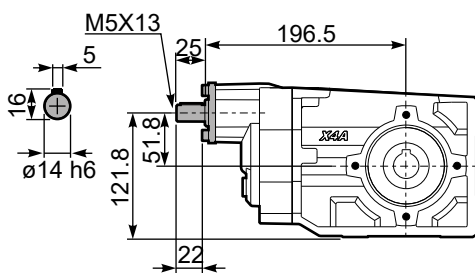

PX43AA.. Single output shaft
Albero semplice in uscita

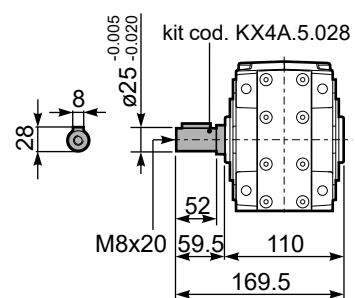



QUICK SELECTION / Selezione veloce The dynamic efficiency is **0.96** for all ratios **input speed (n₁) = 1400 min⁻¹**

Output Speed n ₂ [min ⁻¹]	Ratio i	Motor power P _{1M} [kW]	Output torque M _{2M} [Nm]	Service factor f.s.	Nominal power P _{1R} [kW]	Nominal torque M _{2R} [Nm]	Available B5 motor flanges				Available B14 motor flanges			Output Shaft 	Ratios code
							-C	-D	-E	-F	-R	-T	-U		
							71	80	90	100 112	80	90	100 112		
232	6.03	3	116	1.2	3.4	135	B							3011	01
151	9.26	3	179	0.9	2.6	155	B							308	02
123	11.36	3	219	1.0	3.1	230	B							2011	03
91	15.36	2.2	218	1.1	2.5	250	B							1611	04
80	17.46	2.2	248	1.0	2.2	250	B							208	05
70	19.97	2.2	284	0.9	1.9	250	B							1311	06
59	23.60	1.5	231	1.1	1.6	250	B							168	07
57	24.45	1.5	239	1.0	1.6	250	B							1111	08
45.6	30.69	1.1	220	1.1	1.2	250	B							138	09
39.6	35.35	1.1	253	1.0	1.1	250	B							811	10
37.3	37.57	1.1	269	0.9	1.0	250	B							118	11
28.8	48.68	0.75	239	1.0	0.78	250	B							611	12
25.8	54.33	0.75	267	0.9	0.70	250	B							88	13
18.7	74.81	0.37	181	1.2	0.43	210	B							68	14

A) Motor Flanges Available
Flange Motore Disponibili

B) Supplied with Reduction Bushing
Fornito con Bussola di Riduzione

B) Available on Request without reduction bushing
Disponibile a Richiesta senza Bussola di Riduzione

C) Motor Flange Holes Position
Posizione Fori Flangia Motore

EN Unit **X52A** is supplied with synthetic oil for lifetime lubrication, no maintenance is necessary. See table 1 for lubrication and recommended quantity. In table 2 please see possible radial loads and axial loads on the gearbox.

I Il riduttore **X52A** viene fornito completo di olio sintetico per la lubrificazione permanente e non necessita di alcuna manutenzione. Vedi tab.1 per oli e quantità consigliati. In tab.2 sono presenti i carichi radiali e assiali applicabili al riduttore.

D Das Getriebe **X52A** ist mit synthetischem Öl gefüllt und ist lebensdauergeschmiert. In Tabelle 1 ist die Schmiermenge und das empfohlene Schmiermittel angegeben. In Tabelle 2 sind die zulässigen Radial - und Axialbelastungen des Getriebes aufgeführt.

F Le réducteur **X52A** est fourni complet avec de l'huile synthétique pour la lubrification permanente et ne nécessite aucun entretien. Voir tableau 1 concernant les huiles et les quantités conseillées. Les charges radiales et axiales applicables au réducteur sont précisées dans le tableau 2.

E El reductor tamaño **X52A** se suministra, lubricado de por vida con aceite sintético y no requieren mantenimiento alguna. Ver tabla 1, para cantidades y aceites recomendados. En la tabla 2, se encuentran las cargas radiales y axiales admitidas por el reductor.

Standard supplied	For these mounting position specify in the order or add oil Per queste posizioni specificare in fase d'ordine o aggiungere olio						
B3	B6	B7	B8	V5	V6	V8	
0.90 LT	1.50LT	0.75 LT	1.40 LT	1.95 LT	1.15 LT	Ask	
SHELL Omala S4 WE 320				ENI Telium VSF 320			

For all details on lubrication and plugs check our website **tab. 1**
Per maggiori dettagli su lubrificazione e tappi olio vedi il nostro sito web

RADIAL AND AXIAL LOADS

Output shaft
Albero di uscita

$$F_{eq} = F_R \frac{144.5}{X+114.5}$$

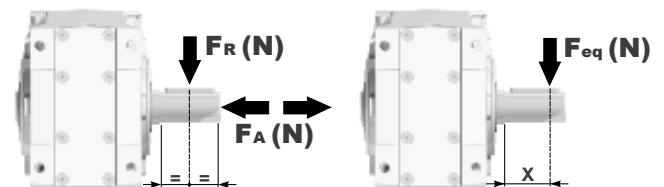

n ₂ [min ⁻¹]	FA	FR	n ₂ [min ⁻¹]	FA	FR	n ₂ [min ⁻¹]	FA	FR
250	600	3000	75	820	4100	15	1660	8300
150	700	3500	50	960	4800			
100	800	4000	25	1350	6750			

F_R On request taper roller bearings to increase radial loads.
A richiesta cuscinetti a rulli conici per aumentare i carichi radiali.

Input shaft
albero in entrata

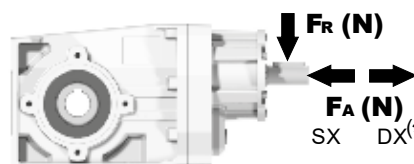

n ₁ [min ⁻¹]	FA	FR
1400	450	2250
900	500	2500
500	600	3000

***Strong axial loads in the DX direction are not allowed.**
Non sono consentiti forti carichi assiali con direzione DX

tab. 2

PX52AC... Basic Gearbox
Riduttore base

Gearbox weight **12.80 kg**
peso riduttore

M. flanges	Kit code	øF	A
71B5	K023.4.041	160	234
80/90B5	K023.4.042	200	236
100/112B5	K023.4.043	250	245
80B14	K085.4.046	120	236
90B14	K085.4.045	140	236
100/112B14	K085.4.047	160	245

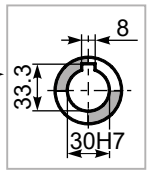
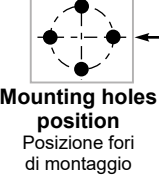
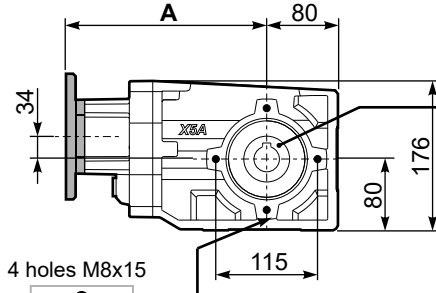
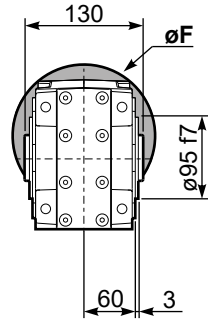

Standard
Hollow shaft

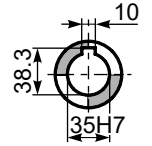

On request
A richiesta

PX52A...FB.. Feet
Piedini

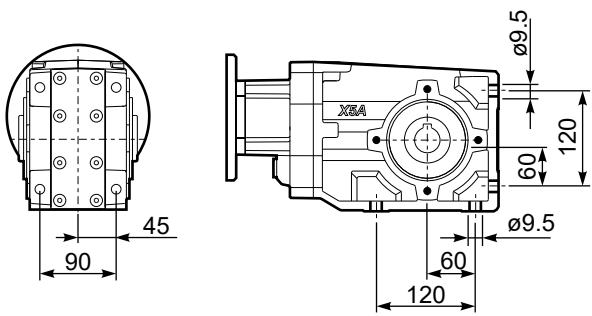

PX52A...-F2.. Output flange
Flangia uscita

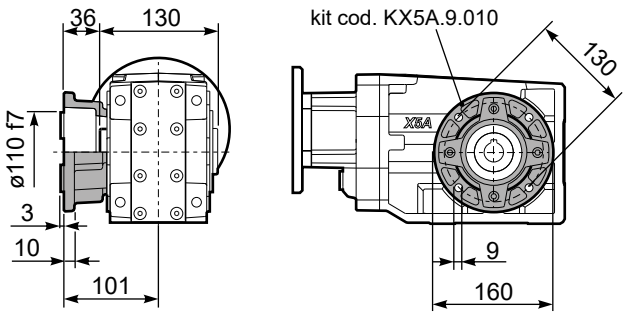

PX52A...-F3.. Output flange
Flangia uscita

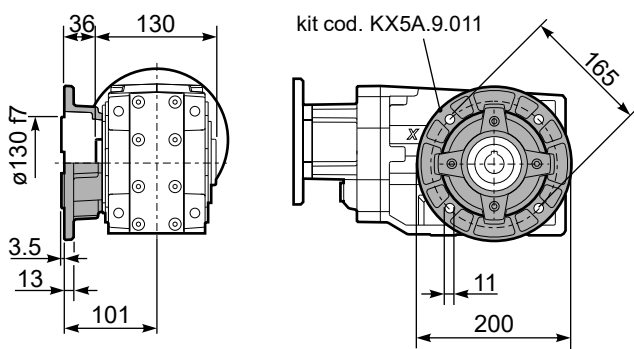

PX52A...-F4.. Output flange
Flangia uscita

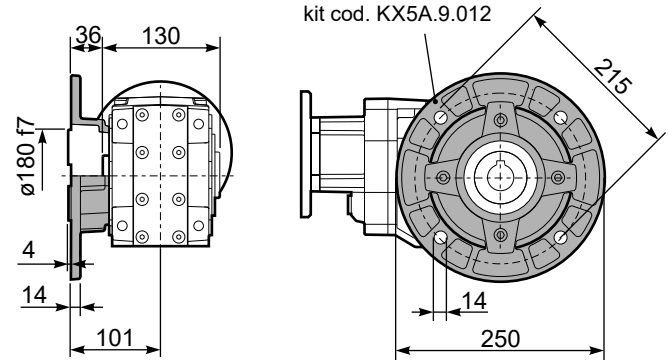

RX52A... Input shaft
Albero in entrata

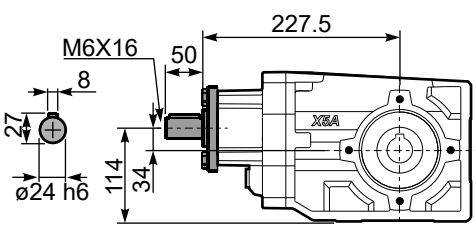

PX52A...BR.. Reaction Arm
Braccio di reazione

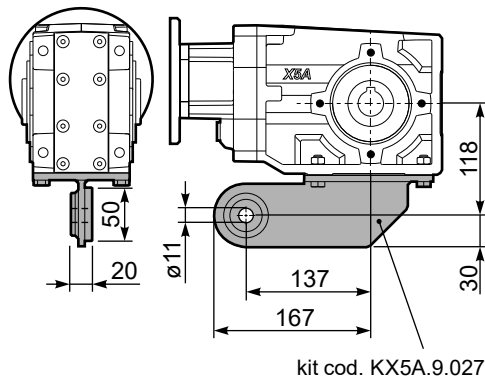

PX52AA.. Single output shaft
Albero semplice in uscita

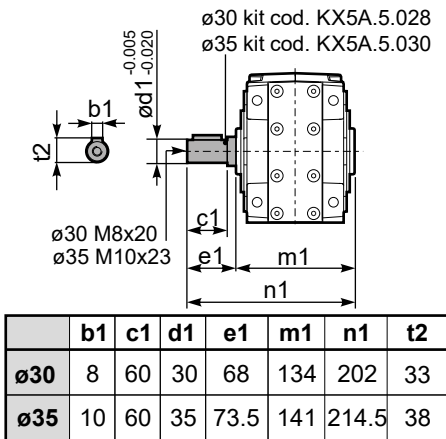



QUICK SELECTION / Selezione veloce The dynamic efficiency is **0.94** for all ratios **input speed (n₁) = 1400 min⁻¹**

Output Speed n ₂ [min ⁻¹]	Ratio i	Motor power P _{1M} [kW]	Output torque M _{2M} [Nm]	Service factor f.s.	Nominal power P _{1R} [kW]	Nominal torque M _{2R} [Nm]	Available B5 motor flanges				Available B14 motor flanges			Output Shaft 	Ratios code
							-B	-C	-D	-E	-Q	-R	-T		
							63	71	80	90	71	80	90		
24.7	56.76	0.55	201	1.2	0.69	250	B				C	C		191311	01
21.3	65.79	0.55	233	1.1	0.59	250	B				C	C		171311	02
18.1	77.23	0.55	274	0.9	0.50	250	B				C	C		151311	03
16.0	87.23	0.37	207	1.2	0.45	250	B				C	C		19138	04
15.2	92.18	0.37	219	1.1	0.42	250	B				C	C		131311	05
13.9	100.47	0.37	238	1.0	0.39	250	B				C	C		19811	06
12.0	116.45	0.37	276	0.9	0.33	250	B				C	C		17811	07
11.1	125.82	0.25	201	1.2	0.31	250	B				C	C	standard ø30	101311	08
9.9	141.66	0.25	227	1.1	0.28	250	B				C	C		13138	09
8.6	163.16	0.25	261	1.0	0.24	250	B				C	C		13811	10
7.8	178.96	0.18	219	1.1	0.22	250	B				C	C	ø35	1788	11
7.2	193.36	0.18	237	1.1	0.20	250	B				C	C	On request	10138	12
6.5	216.84	0.18	265	0.9	0.18	250	B				C	C		71311	13
5.5	252.36	0.12	200	1.3	0.15	250	B				C	C		9138	14
4.8	290.67	0.12	230	1.1	0.13	250	B				C	C		9811	15
4.2	333.23	0.12	263	0.9	0.12	250	B				C	C		7138	16
3.6	383.82	0.12	303	0.8	0.10	250	B				C	C		7811	17
3.1	446.70	0.12*	353	0.7	0.09	250	B				C	C		988	18
2.4	589.85	0.12*	466	0.5	0.07	250	B				C	C		788	19

Motor Flanges Available Flange Motore Disponibili
B) Supplied with Reduction Bushing Fornito con Bussola di Riduzione
B) Available on Request without reduction bushing Disponibile a Richiesta senza Bussola di Riduzione
C) Motor Flange Holes Position Posizione Fori Flangia Motore

* Power higher than the maximum one which can be supported by the gearbox. Select according to the torque M_{2R}
 Potenza superiore a quella massima sopportabile dal riduttore. Selezionare in base al momento torcente M_{2R}

EN Unit **X53A** is supplied with synthetic oil for lifetime lubrication, no maintenance is necessary. See table 1 for lubrication and recommended quantity. In table 2 please see possible radial loads and axial loads on the gearbox.

I Il riduttore **X53A** viene fornito completo di olio sintetico per la lubrificazione permanente e non necessita di alcuna manutenzione. Vedi tab.1 per oli e quantità consigliati. In tab.2 sono presenti i carichi radiali e assiali applicabili al riduttore.

D Das Getriebe **X53A** ist mit synthetischem Öl gefüllt und ist lebensdauergeschmiert. In Tabelle 1 ist die Schmiermenge und das empfohlene Schmiermittel angegeben. In Tabelle 2 sind die zulässigen Radial- und Axialbelastungen des Getriebes aufgeführt.

F Le réducteur **X53A** est fourni complet avec de l'huile synthétique pour la lubrification permanente et ne nécessite aucun entretien. Voir tableau 1 concernant les huiles et les quantités conseillées. Les charges radiales et axiales applicables au réducteur sont précisées dans le tableau 2.

E El reductor tamaño **X53A** se suministra, lubricado de por vida con aceite sintético y no requieren mantenimiento alguna. Ver tabla 1, para cantidades y aceites recomendados. En la tabla 2, se encuentran las cargas radiales y axiales admitidas por el reductor.

Standard supplied	For these mounting position specify in the order or add oil Per queste posizioni specificare in fase d'ordine o aggiungere olio					
1.30 LT	1.55 LT	0.85 LT	1.45 LT	2.10 LT	1.25 LT	Ask
SHELL Omala S4 WE 320				ENI Telium VSF 320		

For all details on lubrication and plugs check our website **tab. 1**
 Per maggiori dettagli su lubrificazione e tappi olio vedi il nostro sito web

RADIAL AND AXIAL LOADS

Output shaft
 Albero di uscita

$F_{eq} = FR \cdot \frac{144.5}{X+114.5}$

n ₂ [min ⁻¹]	FA	FR	n ₂ [min ⁻¹]	FA	FR	n ₂ [min ⁻¹]	FA	FR
250	600	3000	75	820	4100	15	1660	8300
150	700	3500	50	960	4800			
100	800	4000	25	1350	6750			

FR On request taper roller bearings to increase radial loads.
 A richiesta cuscinetti a rulli conici per aumentare i carichi radiali.

Input shaft
 albero in entrata

n ₁ [min ⁻¹]	FA [N]	FR [N]
1400	400	2000
900	440	2200
500	440	2200

*Strong axial loads in the DX direction are not allowed.
 Non sono consentiti forti carichi assiali con direzione DX

tab. 2

PX53AC... Basic Gearbox
Riduttore base

Gearbox weight **12.65 kg**
peso riduttore

M. flanges	Kit code	øF	A
63B5	K063.4.041	140	246
71B5	K063.4.042	160	244
80/90B5	K063.4.043	200	246
71B14	K063.4.047	105	244
80B14	K063.4.046	120	246
90B14	K063.4.041	140	246

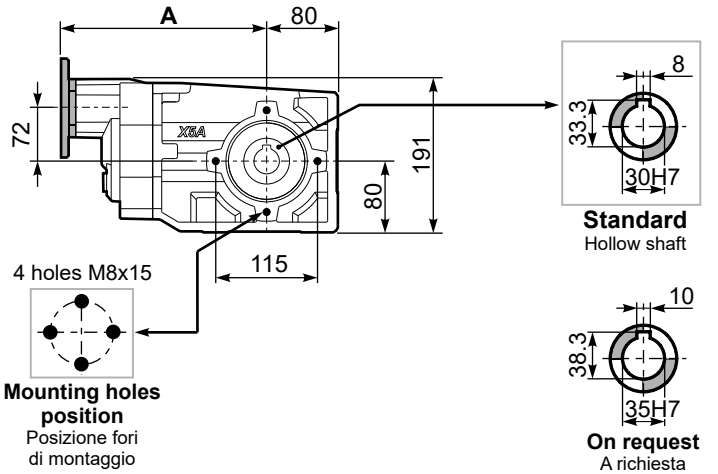
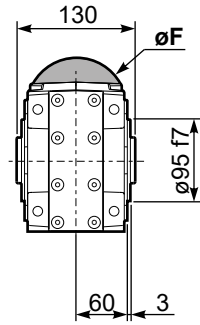

PX53A...FB.. Feet
Piedini

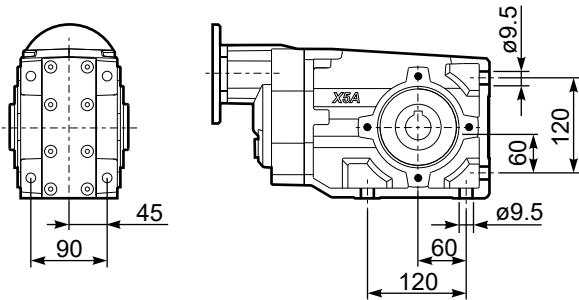

PX53A...-F2.. Output flange
Flangia uscita

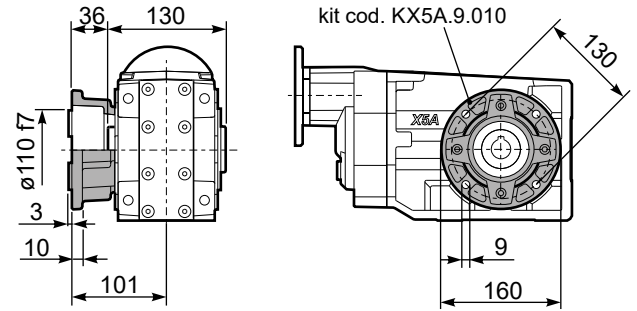

PX53A...-F3.. Output flange
Flangia uscita

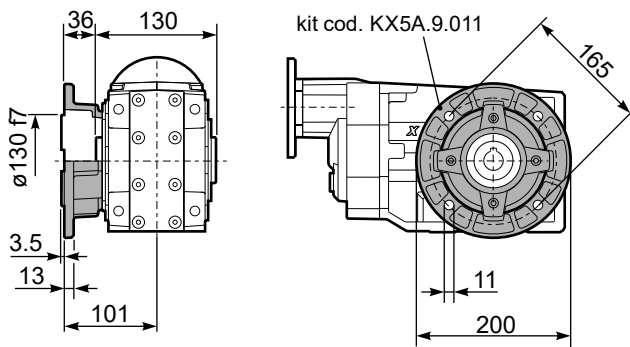

PX53A...-F4.. Output flange
Flangia uscita

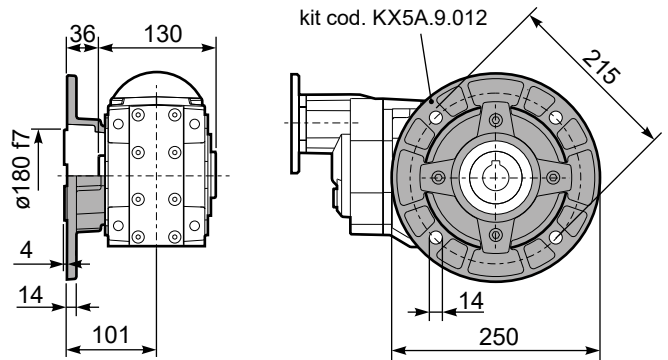

RX53A... Input shaft
Albero in entrata

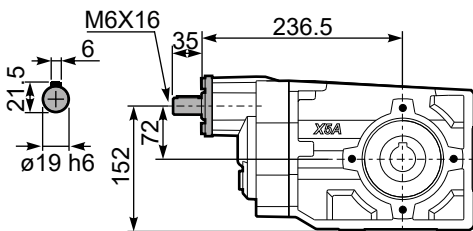

PX53A...BR.. Reaction Arm
Braccio di reazione

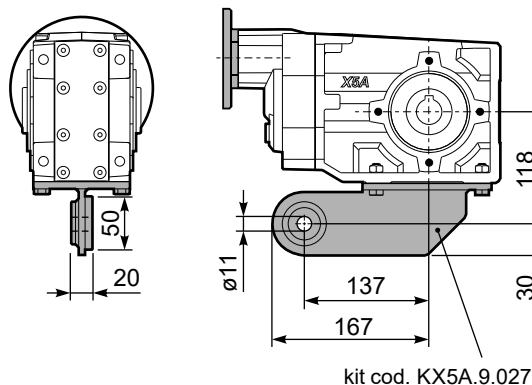

PX53A.. Single output shaft
Albero semplice in uscita

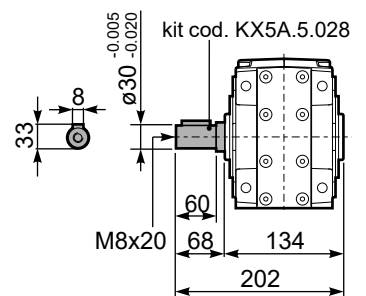



QUICK SELECTION / Selezione veloce The dynamic efficiency is **0.96** for all ratios **input speed (n₁) = 1400 min⁻¹**

Output Speed n ₂ [min ⁻¹]	Ratio i	Motor power P _{1M} [kW]	Output torque M _{2M} [Nm]	Service factor f.s.	Nominal power P _{1R} [kW]	Nominal torque M _{2R} [Nm]	Available B5 motor flanges					Available B14 motor flanges				Output Shaft 	Ratios code
							-C	-D	-E	-F	-G	-R	-T	-U	-V		
							71	80	90	100 112	132	80	90	100 112	132		
232	6.03	5.5	211	1.1	6.1	240	B								3011	01	
151	9.26	4	238	1.1	4.5	270	B								308	02	
123	11.36	4	291	1.2	4.7	350	B								2011	03	
91	15.36	4	394	1.0	3.8	385	B								1611	04	
80	17.46	4	448	0.9	3.5	400	B								208	05	
70	19.97	3	386	1.1	3.1	410	B								1311	06	
59	23.60	3	456	0.9	2.7	410	B								168	07	
57	24.45	3	472	0.9	2.6	410	B								1111	08	
45.6	30.69	2.2	436	0.9	2.0	410	B								138	09	
39.6	35.35	1.5	346	1.2	1.8	410	B								811	10	
37.3	37.57	1.5	368	1.1	1.7	410	B								118	11	
28.8	48.68	1.1	348	1.0	1.1	365	B								611	12	
25.8	54.33	1.1	389	1.1	1.2	410	B								88	13	
18.7	74.81	0.75	367	1.0	0.73	360	B								68	14	

Motor Flanges Available Flange Motore Disponibili **B) Supplied with Reduction Bushing** Fornito con Bussola di Riduzione **B) Available on Request without reduction bushing** Disponibile a Richiesta senza Bussola di Riduzione **C) Motor Flange Holes Position** Posizione Fori Flangia Motore

EN Unit **X62A** is supplied with synthetic oil for lifetime lubrication, no maintenance is necessary. See table 1 for lubrication and recommended quantity. In table 2 please see possible radial loads and axial loads on the gearbox.

I Il riduttore **X62A** viene fornito completo di olio sintetico per la lubrificazione permanente e non necessita di alcuna manutenzione. Vedi tab.1 per oli e quantità consigliati. In tab.2 sono presenti i carichi radiali e assiali applicabili al riduttore.

D Das Getriebe **X62A** ist mit synthetischem Öl gefüllt und ist lebensdauergeschmiert. In Tabelle 1 ist die Schmiermenge und das empfohlene Schmiermittel angegeben. In Tabelle 2 sind die zulässigen Radial - und Axialbelastungen des Getriebes aufgeführt.

F Le réducteur **X62A** est fourni complet avec de l'huile synthétique pour la lubrification permanente et ne nécessite aucun entretien. Voir tableau 1 concernant les huiles et les quantités conseillées. Les charges radiales et axiales applicables au réducteur sont précisées dans le tableau 2.

E El reductor tamaño **X62A** se suministra, lubricado de por vida con aceite sintético y no requieren mantenimiento alguna. Ver tabla 1, para cantidades y aceites recomendados. En la tabla 2, se encuentran las cargas radiales y axiales admitidas por el reductor.

Standard supplied	For these mounting position specify in the order or add oil Per queste posizioni specificare in fase d'ordine o aggiungere olio						
B3	B6	B7	B8	V5	V6	V8	V8
1.25 LT	1.70 LT	0.95 LT	1.60 LT	2.45 LT	1.50 LT	Ask	Ask
SHELL Omala S4 WE 320				ENI Telium VSF 320			

For all details on lubrication and plugs check our website **tab. 1**
Per maggiori dettagli su lubrificazione e tappi olio vedi il nostro sito web

RADIAL AND AXIAL LOADS

Output shaft

Albero di uscita

$$F_{eq} = F_R \cdot \frac{168}{X+138}$$

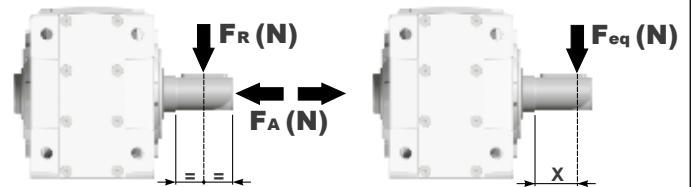

n ₂ [min ⁻¹]	FA	FR	n ₂ [min ⁻¹]	FA	FR	n ₂ [min ⁻¹]	FA	FR
250	600	3000	75	890	4450	15	1660	8300
150	700	3500	50	1140	5700			
100	780	3900	25	1330	6650			

FR On request taper roller bearings to increase radial loads.
A richiesta cuscinetti a rulli conici per aumentare i carichi radiali.

Input shaft

albero in entrata

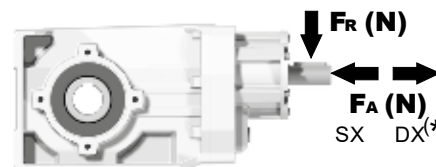

n ₁ [min ⁻¹]	FA	FR
1400	450	2250
900	500	2500
500	600	3000

***Strong axial loads in the DX direction are not allowed.**
Non sono consentiti forti carichi assiali con direzione DX

tab. 2

PX62AC... Basic Gearbox
Riduttore base

Gearbox weight
peso riduttore **15.80 kg**

M. flanges	Kit code	øF	A
71B5	K023.4.041	160	253
80/90B5	K023.4.042	200	255
100/112B5	K023.4.043	250	264
132B5	KC51.4.043	300	285
<hr/>			
80B14	K085.4.046	120	255
90B14	K085.4.045	140	255
100/112B14	K085.4.047	160	264
132B14	KC51.4.041	200	285

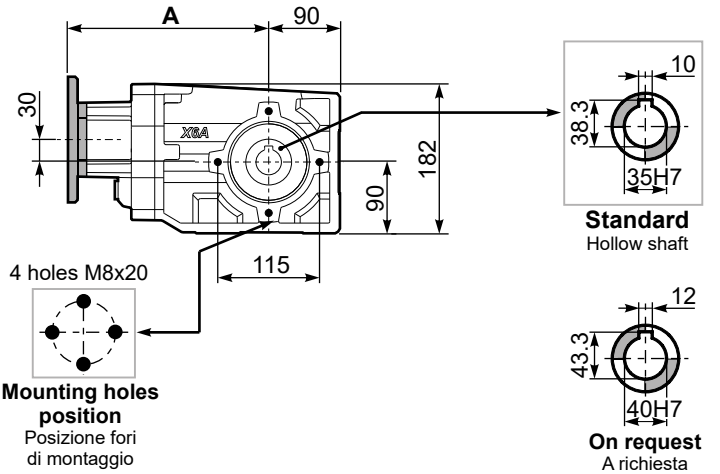
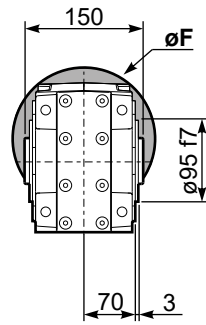

PX62A...FB.. Feet
Piedini

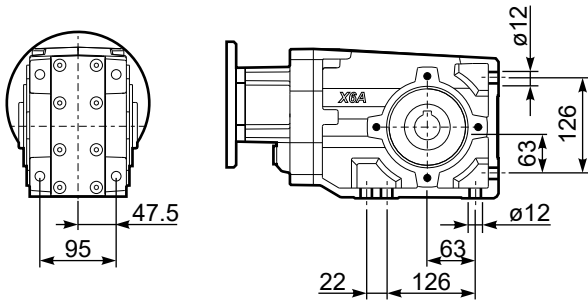

PX62A...-F2.. Output flange
Flangia uscita

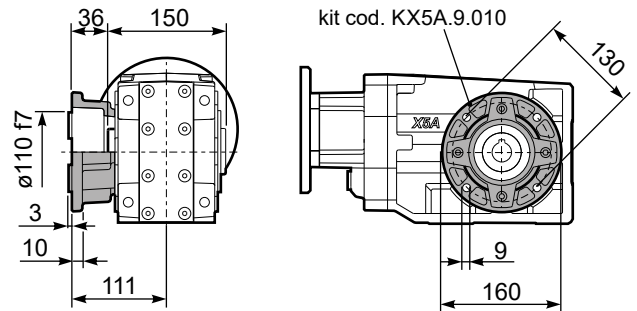

PX62A...-F3.. Output flange
Flangia uscita

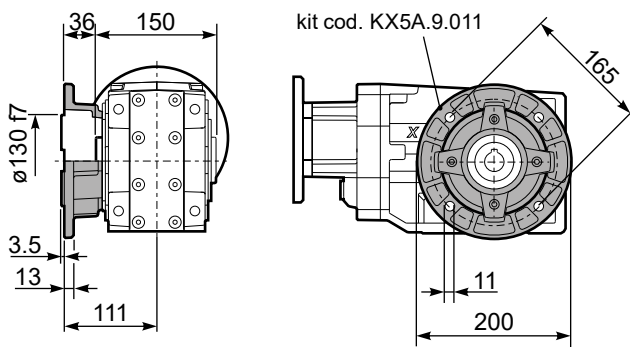

PX62A...-F4.. Output flange
Flangia uscita

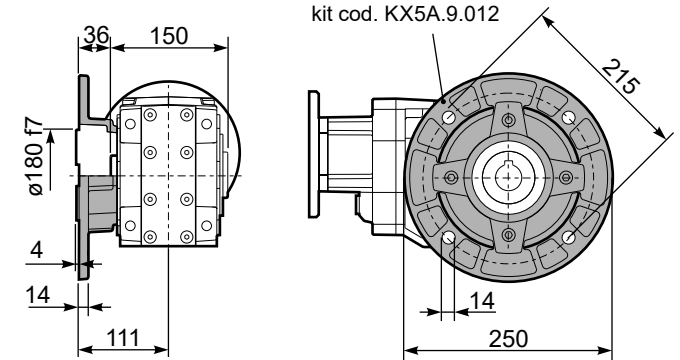

RX62A... Input shaft
Albero in entrata

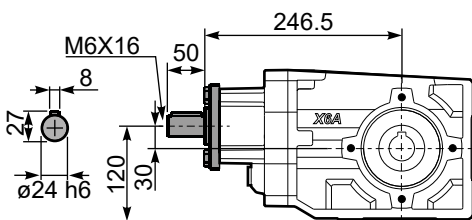

PX62A...BR.. Reaction Arm
Braccio di reazione

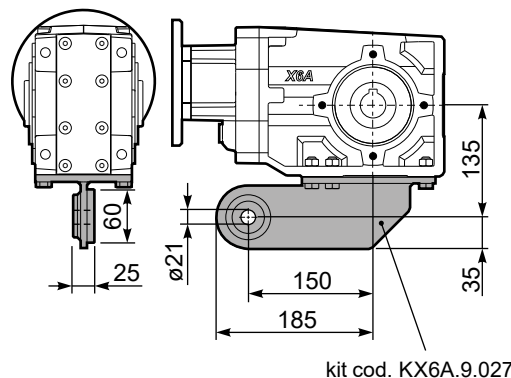

PX62AA.. Single output shaft
Albero semplice in uscita

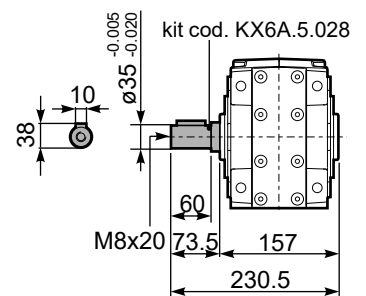



QUICK SELECTION / Selezione veloce The dynamic efficiency is **0.94** for all ratios **input speed (n₁) = 1400 min⁻¹**

Output Speed n ₂ [min ⁻¹]	Ratio i	Motor power P _{1M} [kW]	Output torque M _{2M} [Nm]	Service factor f.s.	Nominal power P _{1R} [kW]	Nominal torque M _{2R} [Nm]	Available B5 motor flanges				Available B14 motor flanges			Output Shaft 	Ratios code
							-B	-C	-D	-E	-Q	-R	-T		
							63	71	80	90	71	80	90		
24.7	56.76	1.1	398	1.0	1.1	410	B				C	C		191311	01
21.3	65.79	0.75	316	1.3	0.97	410	B				C	C		171311	02
18.1	77.23	0.75	371	1.1	0.83	410	B				C	C		151311	03
16.0	87.23	0.75	420	1.0	0.73	410	B				C	C		19138	04
15.2	92.18	0.75	443	0.9	0.69	410	B				C	C		131311	05
13.9	100.47	0.55	357	1.2	0.64	410	B				C	C		19811	06
12.0	116.45	0.55	413	1.0	0.55	410	B				C	C		17811	07
11.1	125.82	0.55	446	0.9	0.51	410	B				C	C		101311	08
9.9	141.66	0.37	336	1.2	0.45	410	B				C	C		13138	09
8.6	163.16	0.37	387	1.1	0.39	410	B				C	C		13811	10
7.8	178.96	0.37	424	1.0	0.36	410	B				C	C		1788	11
7.2	193.36	0.37	459	0.9	0.33	410	B				C	C		10138	12
6.5	216.84	0.25	347	1.2	0.29	410	B				C	C		71311	13
5.5	252.36	0.25	404	1.0	0.25	410	B				C	C		9138	14
4.8	290.67	0.25	465	0.9	0.22	410	B				C	C		9811	15
4.2	333.23	0.18	408	1.0	0.19	410	B				C	C		7138	16
3.6	383.82	0.18	470	0.9	0.17	410	B				C	C		7811	17
3.1	446.70	0.12	353	1.2	0.14	410	B				C	C		988	18
2.4	589.85	0.12	466	0.9	0.11	410	B				C	C		788	19

 Motor Flanges Available Flange Motore Disponibili
 B) Supplied with Reduction Bushing Fornito con Bussola di Riduzione
 B) Available on Request without reduction bushing Disponibile a Richiesta senza Bussola di Riduzione
 C) Motor Flange Holes Position Posizione Fori Flangia Motore

EN Unit **X63A** is supplied with synthetic oil for lifetime lubrication, no maintenance is necessary. See table 1 for lubrication and recommended quantity. In table 2 please see possible radial loads and axial loads on the gearbox.

I Il riduttore **X63A** viene fornito completo di olio sintetico per la lubrificazione permanente e non necessita di alcuna manutenzione. Vedi tab.1 per oli e quantità consigliati. In tab.2 sono presenti i carichi radiali e assiali applicabili al riduttore.

D Das Getriebe **X63A** ist mit synthetischem Öl gefüllt und ist lebensdauergeschmiert. In Tabelle 1 ist die Schmiermenge und das empfohlene Schmiermittel angegeben. In Tabelle 2 sind die zulässigen Radial- und Axialbelastungen des Getriebes aufgeführt.

F Le réducteur **X63A** est fourni complet avec de l'huile synthétique pour la lubrification permanente et ne nécessite aucun entretien. Voir tableau 1 concernant les huiles et les quantités conseillées. Les charges radiales et axiales applicables au réducteur sont précisées dans le tableau 2.

E El reductor tamaño **X63A** se suministra, lubricado de por vida con aceite sintético y no requieren mantenimiento alguna. Ver tabla 1, para cantidades y aceites recomendados. En la tabla 2, se encuentran las cargas radiales y axiales admitidas por el reductor.

Standard supplied	For these mounting position specify in the order or add oil Per queste posizioni specificare in fase d'ordine o aggiungere olio						
B3	B6	B7	B8	V5	V6	V8	
1.80 LT	1.80 LT	1.05 LT	1.70 LT	2.60 LT	1.65 LT	Ask	
SHELL Omala S4 WE 320				ENI Telium VSF 320			

For all details on lubrication and plugs check our website **tab. 1**
Per maggiori dettagli su lubrificazione e tappi olio vedi il nostro sito web

RADIAL AND AXIAL LOADS

Output shaft
Albero di uscita

$F_{eq} = F_R \cdot \frac{168}{X+138}$

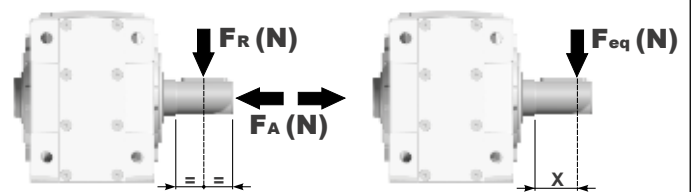

n ₂ [min ⁻¹]	FA	FR	n ₂ [min ⁻¹]	FA	FR	n ₂ [min ⁻¹]	FA	FR
250	600	3000	75	890	4450	15	1660	8300
150	700	3500	50	1140	5700			
100	780	3900	25	1330	6650			

FR On request taper roller bearings to increase radial loads.
A richiesta cuscinetti a rulli conici per aumentare i carichi radiali.

Input shaft
albero in entrata

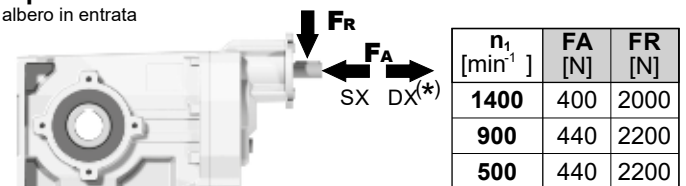

n ₁ [min ⁻¹]	FA [N]	FR [N]
1400	400	2000
900	440	2200
500	440	2200

*Strong axial loads in the DX direction are not allowed.
Non sono consentiti forti carichi assiali con direzione DX

tab. 2

PX63AC... Basic Gearbox
Riduttore base

Gearbox weight
peso riduttore **15.98 kg**

M. flanges	Kit code	øF	A
63B5	K063.4.041	140	265
71B5	K063.4.042	160	263
80/90B5	K063.4.043	200	265
71B14	K063.4.047	105	263
80B14	K063.4.046	120	265
90B14	K063.4.041	140	265

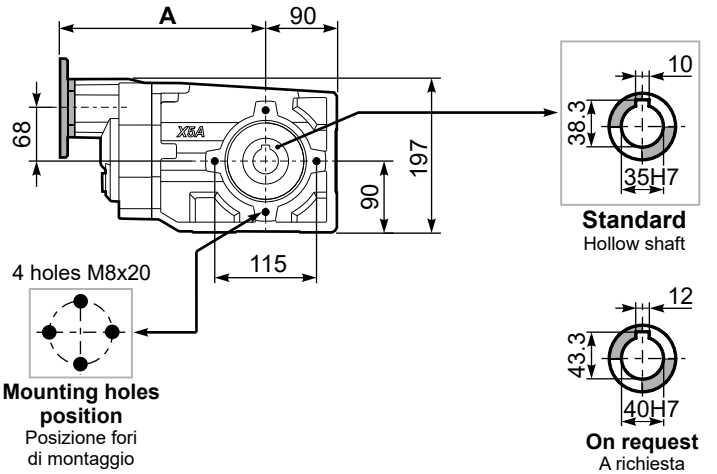
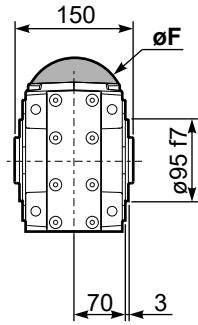

PX63A...FB.. Feet
Piedini

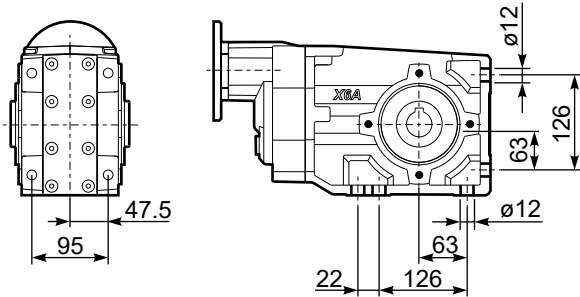

PX63A...-F2.. Output flange
Flangia uscita

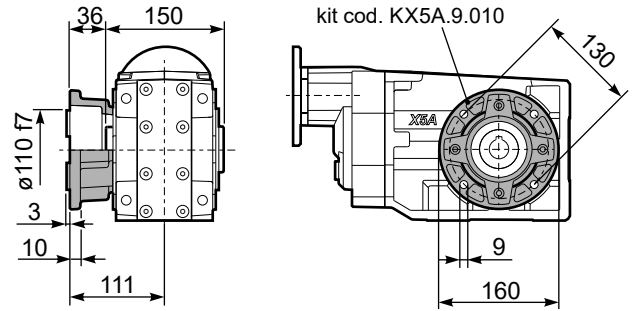

PX63A...-F3.. Output flange
Flangia uscita

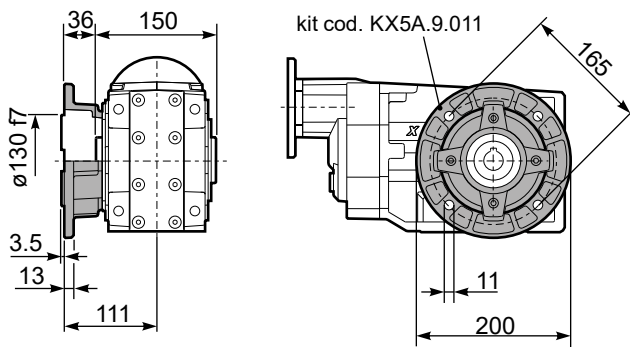

PX63A...-F4.. Output flange
Flangia uscita

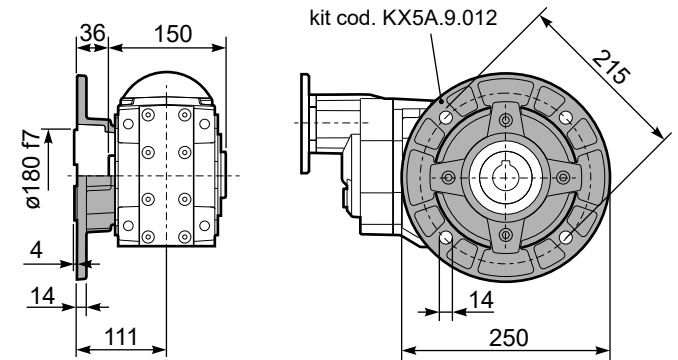

RX63A... Input shaft
Albero in entrata

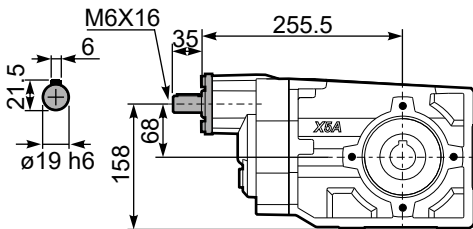

PX63A...BR.. Reaction Arm
Braccio di reazione

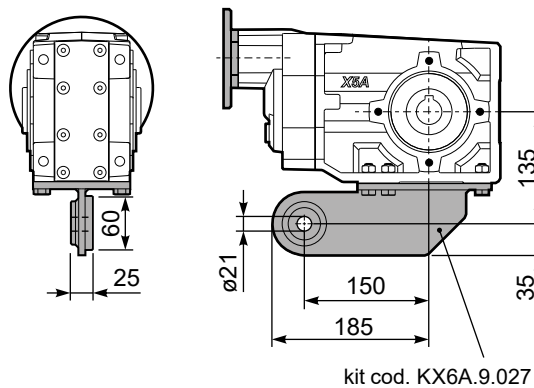

PX63AA.. Single output shaft
Albero semplice in uscita

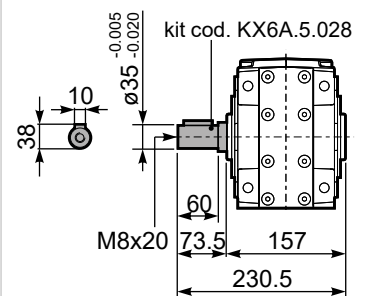

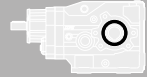

QUICK SELECTION / Selezione veloce

input speed (n_1) = 1400 min⁻¹

Output Speed n_2 [min ⁻¹]	Ratio i	Motor power P_{1M} [kW]	Output torque M_{2M} [Nm]	Service factor f.s.	Nominal power P_{1R} [kW]	Nominal torque M_{2R} [Nm]	Available B5 motor flanges					Available B14 motor flanges				Output Shaft Ø	Ratios code
							-C	-D	-E	-F	-G	-R	-T	-U	-V		
							71	80	90	100 112	132	80	90	100 112	132		
176	7.94	7.5	369	1.0	7.5	380	B									302418	01
153	9.13	7.5	425	0.9	6.7	390	B									302416	02
131	10.66	5.5	366	1.1	6.0	410	B									302414	03
94	14.97	5.5	514	1.1	6.0	580	B									202418	04
81	17.21	5.5	591	1.0	5.4	600	B									202416	05
69	20.24	5.5	695	1.0	5.2	675	B									162418	06
60	23.27	4	585	1.2	4.5	675	B									162416	07
53	26.31	4	661	1.0	4.0	675	B									132418	08
46.3	30.25	4	760	0.9	3.5	675	B									132416	09
39.6	35.32	3	668	1.0	3.0	675	B									132414	10
37.8	37.03	3	701	1.0	2.8	675	B									112416	11
32.4	43.23	2.2	602	1.1	2.4	675	B									112414	12
30.1	46.58	2.2	649	1.0	2.3	675	B									82418	13
26.1	53.55	2.2	746	0.9	2.0	675	B									82416	14
22.4	62.52	1.5	600	1.1	1.7	675	B									82414	15
19.0	73.75	1.1	517	1.1	1.2	580	B									62416	16
16.3	86.09	1.1	604	1.1	1.2	675	B									62414	17

The dynamic efficiency is **0.94** for all ratios

Motor Flanges Available Flange Motore Disponibili
 B) Supplied with Reduction Bushing Fornito con Bussola di Riduzione
 B) Available on Request without reduction bushing Disponibile a Richiesta senza Bussola di Riduzione
 C) Motor Flange Holes Position Posizione Fori Flangia Motore

EN Unit **X73C** is supplied with synthetic oil for lifetime lubrication, no maintenance is necessary. See table 1 for lubrication and recommended quantity. In table 2 please see possible radial loads and axial loads on the gearbox.

I Il riduttore **X73C** viene fornito completo di olio sintetico per la lubrificazione permanente e non necessita di alcuna manutenzione. Vedi tab.1 per oli e quantità consigliati. In tab.2 sono presenti i carichi radiali e assiali applicabili al riduttore.

D Das Getriebe **X73C** ist mit synthetischem Öl gefüllt und ist lebensdauergeschmiert. In Tabelle 1 ist die Schmiermenge und das empfohlene Schmiermittel angegeben. In Tabelle 2 sind die zulässigen Radial - und Axialbelastungen des Getriebes aufgeführt.

F Le réducteur **X73C** est fourni complet avec de l'huile synthétique pour la lubrification permanente et ne nécessite aucun entretien. Voir tableau 1 concernant les huiles et les quantités conseillées.

Les charges radiales et axiales applicables au réducteur sont précisées dans le tableau 2.

E El reductor tamaño **X73C** se suministra, lubricado de por vida con aceite sintético y no requieren mantenimiento alguna. Ver tabla 1, para cantidades y aceites recomendados. En la tabla 2, se encuentran las cargas radiales y axiales admitidas por el reductor.

Standard supplied	For these mounting position specify in the order or add oil Per queste posizioni specificare in fase d'ordine o aggiungere olio					
B3	B6	B7	B8	V5	V6	V8
2.45 LT	2.55 LT	1.80 LT	1.95 LT	4.05 LT	2.55 LT	Ask
SHELL Omala S4 WE 320			ENI Telium VSF 320			

For all details on lubrication and plugs check our website **tab. 1**
Per maggiori dettagli su lubrificazione e tappi olio vedi il nostro sito web

RADIAL AND AXIAL LOADS

Output shaft
Albero di uscita

$F_{eq} = FR \cdot \frac{178.5}{X+143.5}$

n_2	FA	FR	n_2	FA	FR	n_2	FA	FR
300	1360	6800	140	1480	7400	70	1720	8600
250	1400	7000	120	1520	7600	40	1840	9200
200	1440	7200	85	1560	7800	15	1920	9600

On request reinforced bearings to increase loads.

A richiesta cuscinetti rinforzati per aumentare i carichi.

Input shaft

Albero di entrata

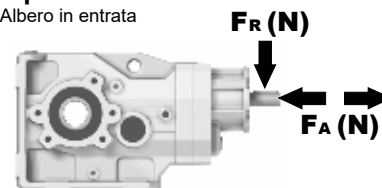

n_1	FA	FR
1400	400	2000
900	440	2200
500	440	2200

tab. 2

PX73CC... Basic Gearbox
Riduttore base

Gearbox weight
peso riduttore **41.0 kg**

M. flanges	Kit code	øF	A
71B5	K023.4.041	160	298.9
80/90B5	K023.4.042	200	300.9
100/112B5	K023.4.043	250	309.9
132B5	KC51.4.043	300	330.9
80B14	K085.4.046	120	300.9
90B14	K085.4.045	140	300.9
100/112B14	K085.4.047	160	309.9
132B14	KC51.4.041	200	330.9

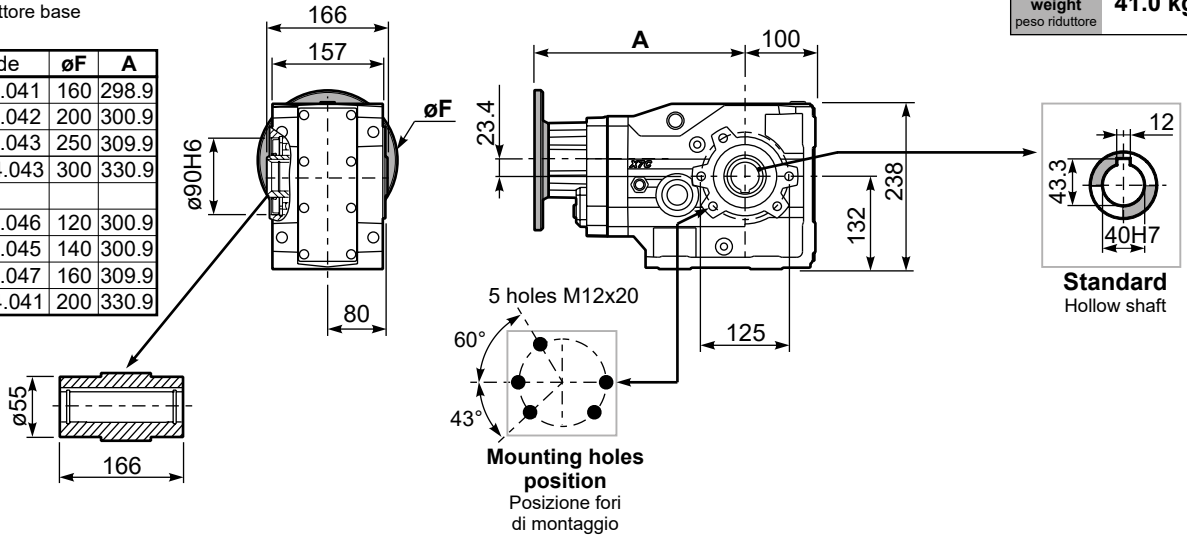

PX73C...FB.. Feet
Piedini

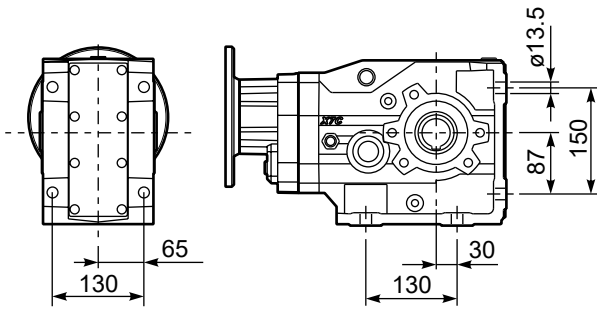

PX73C...-F4.. Output flange
Flangia uscita

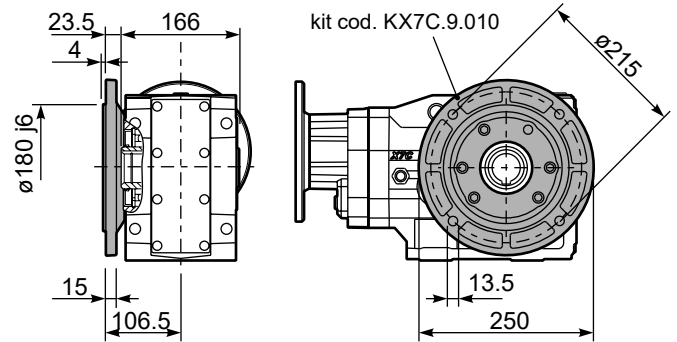

PX73C...BR.. Reaction Arm
Braccio di reazione

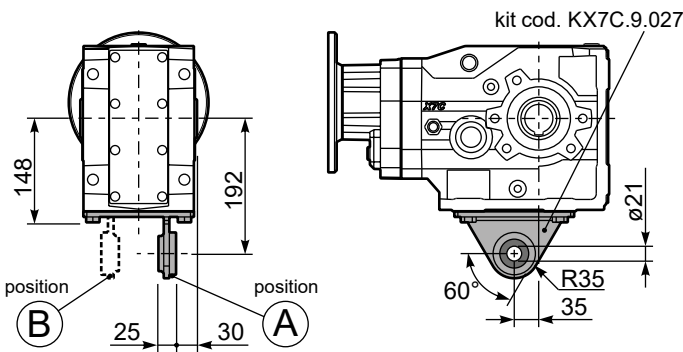

RX73C... Input shaft
Albero in entrata

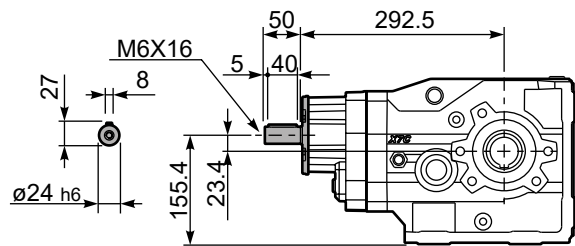

PX73CA... Single shaft
Albero lento semplice

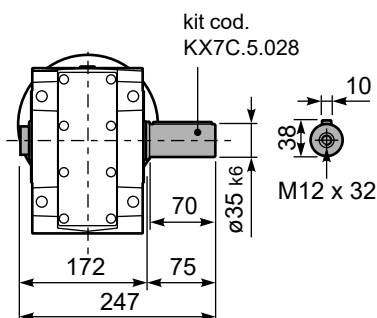

PX73CB... Double shaft
Albero lento bisp.

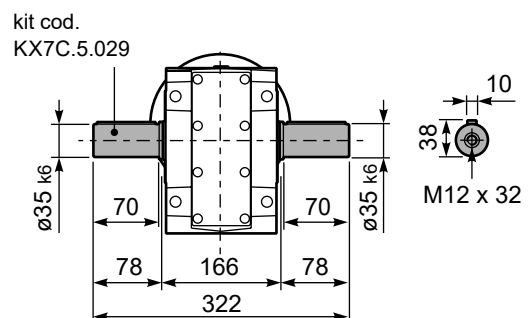



QUICK SELECTION / Selezione veloce

input speed (n_1) = 1400 min⁻¹

Output Speed n_2 [min ⁻¹]	Ratio i	Motor power P_{1M} [kW]	Output torque M_{2M} [Nm]	Service factor $f.s.$	Nominal power P_{1R} [kW]	Nominal torque M_{2R} [Nm]	Available B5 motor flanges				Available B14 motor flanges			Output Shaft 	Ratios code
							-B	-C	-D	-E	-Q	-R	-T		
							63	71	80	90	71	80	90		
18.7	74.79	1.5	704	1.0	1.4	675	B				C	C		19132418	01
16.3	85.99	1.1	591	1.1	1.3	675	B				C	C		19132416	02
14.0	99.66	1.1	685	1.0	1.1	675	B				C	C		17132416	03
12.0	116.35	0.75	548	1.2	0.92	675	B				C	C		17132414	04
11.5	121.45	0.75	572	1.2	0.89	675	B				C	C		13132418	05
10.0	139.64	0.75	658	1.0	0.77	675	B				C	C		13132416	06
9.2	152.21	0.75	717	0.9	0.71	675	B				C	C		19082416	07
8.6	163.02	0.55	567	1.2	0.66	675	B				C	C		13132414	08
7.9	177.69	0.55	618	1.1	0.61	675	B				C	C		19082414	09
6.8	205.95	0.55	716	0.9	0.52	675	B				C	C		17082414	10
6.3	222.52	0.55	774	0.9	0.48	675	B				C	C		10132414	11
5.6	248.76	0.37	578	1.2	0.43	675	B				C	C		9132416	12
4.8	290.41	0.37	675	1.0	0.37	675	B				C	C		9132414	13
4.1	337.39	0.37	784	0.9	0.32	675	B				C	C		10082416	14
3.6	393.88	0.25	618	1.1	0.27	675	B				C	C		10082414	15
3.2	440.33	0.25	690	1.0	0.24	675	B				C	C		9082416	16
2.7	514.06	0.18	616	1.1	0.21	675	B				C	C		9082414	17
2.4	581.44	0.18	697	1.0	0.18	675	B				C	C		7082416	18
2.1	678.79	0.12	526	1.3	0.16	675	B				C	C		7082414	19

The dynamic efficiency is **0.92** for all ratios

Motor Flanges Available
Flange Motore Disponibili

B) Supplied with Reduction Bushing
Fornito con Bussola di Riduzione

B) Available on Request without reduction bushing
Disponibile a Richiesta senza Bussola di Riduzione

C) Motor Flange Holes Position
Posizione Fori Flangia Motore

EN Unit **X74C** is supplied with synthetic oil for lifetime lubrication, no maintenance is necessary. See table 1 for lubrication and recommended quantity. In table 2 please see possible radial loads and axial loads on the gearbox.

I Il riduttore **X74C** viene fornito completo di olio sintetico per la lubrificazione permanente e non necessita di alcuna manutenzione. Vedi tab.1 per oli e quantità consigliati. In tab.2 sono presenti i carichi radiali e assiali applicabili al riduttore.

D Das Getriebe **X74C** ist mit synthetischem Öl gefüllt und ist lebensdauergeschmiert. In Tabelle 1 ist die Schmiermenge und das empfohlene Schmiermittel angegeben. In Tabelle 2 sind die zulässigen Radial - und Axialbelastungen des Getriebes aufgeführt.

F Le réducteur **X74C** est fourni complet avec de l'huile synthétique pour la lubrification permanente et ne nécessite aucun entretien. Voir tableau 1 concernant les huiles et les quantités conseillées. Les charges radiales et axiales applicables au réducteur sont précisées dans le tableau 2.

E El reductor tamaño **X74C** se suministra, lubricado de por vida con aceite sintético y no requieren mantenimiento alguna. Ver tabla 1, para cantidades y aceites recomendados. En la tabla 2, se encuentran las cargas radiales y axiales admitidas por el reductor.

Standard supplied	For these mounting position specify in the order or add oil Per queste posizioni specificare in fase d'ordine o aggiungere olio					
3.55 LT	2.65 LT	1.90 LT	2.05 LT	4.25 LT	2.65 LT	Ask
SHELL Omala S4 WE 320			ENI Telium VSF 320			

For all details on lubrication and plugs check our website **tab. 1**
Per maggiori dettagli su lubrificazione e tappi olio vedi il nostro sito web

RADIAL AND AXIAL LOADS

Output shaft
Albero di uscita

$F_{eq} = FR \cdot \frac{178.5}{X+143.5}$

n_2	FA	FR	n_2	FA	FR	n_2	FA	FR
300	1360	6800	140	1480	7400	70	1720	8600
250	1400	7000	120	1520	7600	40	1840	9200
200	1440	7200	85	1560	7800	15	1920	9600

On request reinforced bearings to increase loads.
A richiesta cuscinetti rinforzati per aumentare i carichi.

Input shaft
Albero in entrata

n_1	FA	FR
1400	240	1200
900	280	1400
500	310	1700

tab. 2

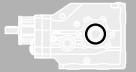

QUICK SELECTION / Selezione veloce

input speed (n_1) = 1400 min⁻¹

Output Speed n_2 [min ⁻¹]	Ratio i	Motor power P_{1M} [kW]	Output torque M_{2M} [Nm]	Service factor $f.s.$	Nominal power P_{1R} [kW]	Nominal torque M_{2R} [Nm]	Available B5 motor flanges					Available B14 motor flanges				Output Shaft 	Ratios code	
							-C	-D	-E	-F	-G	-R	-T	-U	-V			
							71	80	90	100 112	132	80	90	100 112	132			
145	9.69	9	560	1.3	12.2	755	B										302418	01
126	11.09	9	641	1.1	9.6	680	B										302416	02
108	12.90	9	746	1.1	9.6	790	B										302414	03
77	18.26	7.5	849	1.1	8.0	935	B										202418	04
67	20.91	7.5	972	1.0	7.5	1000	B										202416	05
58	24.32	5.5	835	1.2	6.4	1000	B										202414	06
49.5	28.27	5.5	971	1.0	5.5	1000	B										162416	07
42.6	32.88	4	826	1.2	4.7	1000	B										162414	08
38.1	36.76	4	924	1.1	4.2	1000	B										132416	09
32.7	42.76	3	809	1.2	3.6	1000	B										132414	10
31.1	45.00	3	851	1.2	3.5	1000	B										112416	11
26.8	52.33	3	990	1.0	3.0	1000	B										112414	12
24.6	56.82	2.2	791	1.1	2.3	850	B										82418	13
21.5	65.07	2.2	906	1.1	2.3	975	B										82416	14
18.5	75.68	2.2	1054	0.9	2.1	1000	B										82414	15
15.6	89.61	1.1	628	1.1	1.2	710	B										62416	16
13.4	104.22	1.1	731	1.1	1.2	820	B										62414	17

The dynamic efficiency is **0.94** for all ratios

- Motor Flanges Available** Flange Motore Disponibili
- B) Supplied with Reduction Bushing** Fornito con Bussola di Riduzione
- B) Available on Request without reduction bushing** Disponibile a Richiesta senza Bussola di Riduzione
- C) Motor Flange Holes Position** Posizione Fori Flangia Motore

EN Unit **X83C** is supplied without lubricant and equipped with a breather, level and drain plugs. User can add mineral oil keeping existing plugs. Should the user wish to fill it with synthetic oil, it is recommended to replace the existing plugs with a closed plug. See table 1 for lubrication and recommended quantity. In table 2 please see possible radial loads and axial loads on the gearbox.

I Il riduttore tipo **X83C** è fornito privo di lubrificazione con tappi di sfiato, livello e scarico olio. L'utente può immettere olio minerale mantenendo i tappi esistenti. Se immetterà olio sintetico, dovrà sostituire i tappi esistenti con altri tipo chiuso. Tab.1 per oli e quantità consigliati. Tab.2 carichi radiali e assiali applicabili al riduttore.

D Das Getriebe der Baugröße **X83C** wird ohne Schmiermittel geliefert. Es ist jedoch mit Einfüllschraube, Überdruckventil und Ablassschraube ausgerüstet. Das benötigte mineralische Öl kann über die Einfüllschraube eingefüllt werden. Sollte synthetisches Öl bevorzugt werden, so ist sind das eingebaute Überdruckventil durch eine geschlossenen Schraube zu ersetzen. In Tabelle 1 ist die Schmiermenge und das empfohlene Schmiermittel angegeben. In Tabelle 2 sind die zulässigen Radial - und Axialbelastungen des Getriebes aufgeführt.

F Le réducteur de type **X83C** est fourni sans lubrification et avec un bouchon de remplissage, de niveau et d'évacuation de l'huile. L'utilisateur peut y verser de l'huile minérale en conservant les bouchons existants. S'il y versera de l'huile synthétique, il devra substituer les bouchons existants avec d'autres bouchons de type fermé. Voir tableau 1 concernant les huiles et les quantités conseillées. Voir tableau 2 concernant les charges radiales et axiales applicables au réducteur.

E El reductor tamaño **X83C** se suministra sin lubricante, provisto de tapones de respiración, nivel y descarga de aceite. El usuario puede utilizar aceite mineral, manteniendo los tapones existentes. Si prefiere utilizar aceite sintético deberá sustituir los tapones existentes por tapones ciegos. La prerreducción se suministra con tapones ciegos, lubricado de por vida con aceite sintético. Ver tabla 1, para cantidades y aceites recomendados. En la tabla 2, se encuentran las cargas radiales y axiales admitidas por el reductor.

B3	B6	B7	B8	V5	V6	V8
2.80 LT	3.10 LT	2.00 LT	2.50 LT	4.95 LT	2.80 LT	Ask
SHELL Omala S2 GX 460				ENI Blasias 460		

For all details on lubrication and plugs check our website [www.angletech.com](#) tab. 1
Per maggiori dettagli su lubrificazione e tappi olio vedi il nostro sito web

RADIAL AND AXIAL LOADS

Output shaft
Albero di uscita

$F_{eq} = F_R \cdot \frac{196.5}{X+156.5}$

n_2	FA	FR	n_2	FA	FR	n_2	FA	FR
300	1700	8500	140	1860	9300	70	2160	10800
250	1760	8800	120	1900	9500	40	2300	11500
200	1800	9000	85	1960	9800	15	2400	12000

On request reinforced bearings to increase loads.
A richiesta cuscinetti rinforzati per aumentare i carichi.

Input shaft
Albero in entrata

n_1	FA	FR
1400	450	2250
900	500	2500
500	600	3000

tab. 2

PX83CC... Basic gearbox
Riduttore base

Gearbox weight
peso riduttore **48.5 kg**

M. flanges	Kit code	øF	A
71B5	K023.4.041	160	315.7
80/90B5	K023.4.042	200	317.7
100/112B5	K023.4.043	250	326.7
132B5	KC51.4.043	300	347.7
80B14	K085.4.046	120	317.7
90B14	K085.4.045	140	317.7
100/112B14	K085.4.047	160	326.7
132B14	KC51.4.041	200	347.7

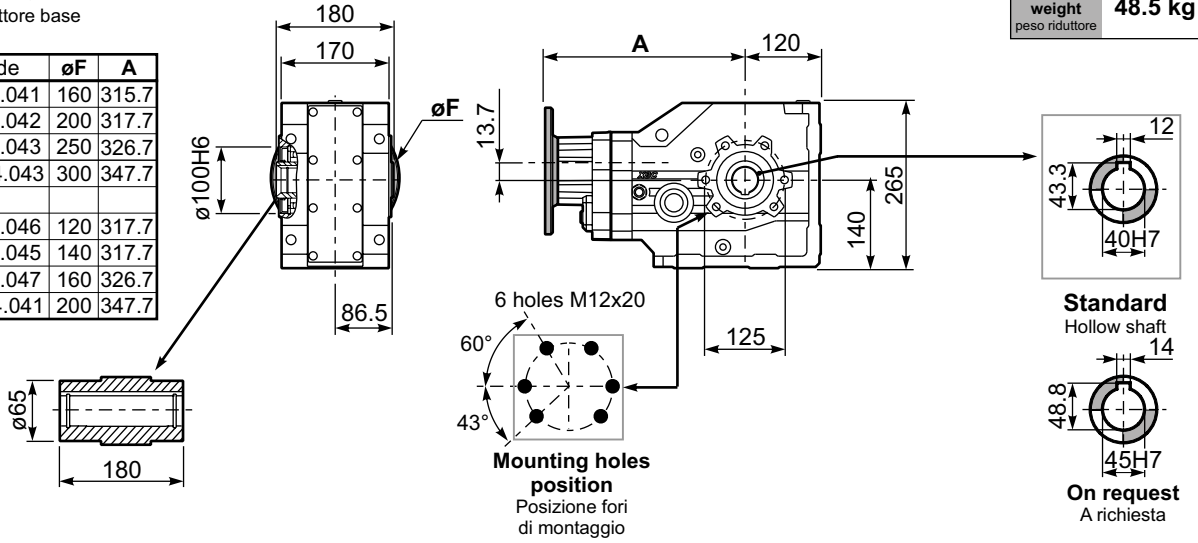

PX83C...FB.. Feet
Piedini

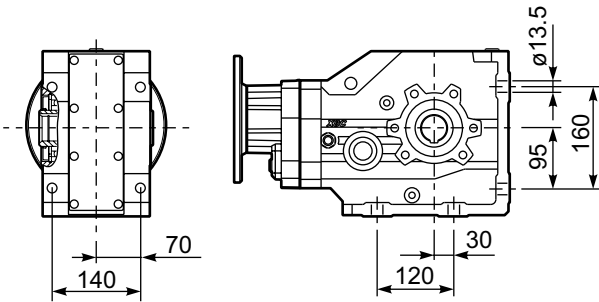

PX83C...-F4.. Output flange
Flangia uscita

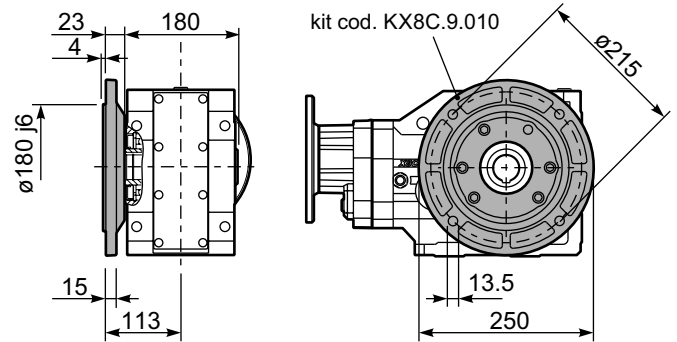

PX83C...BR.. Reaction Arm
Braccio di reazione

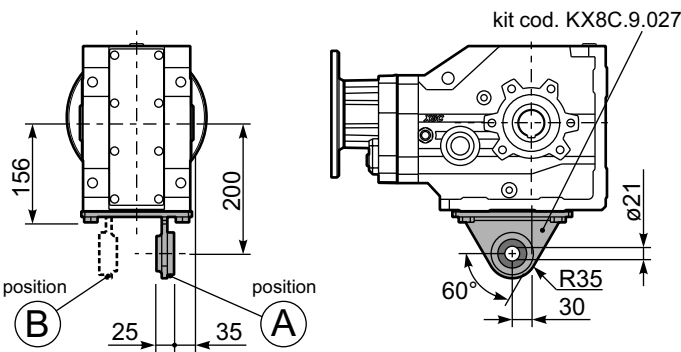

RX83C... Input shaft
Albero in entrata

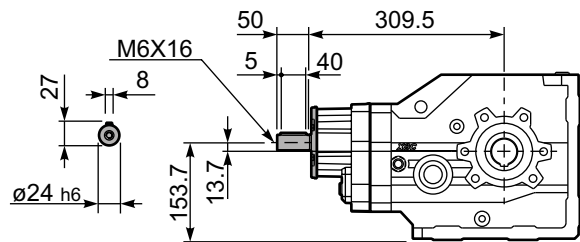

PX83CA... Single shaft
Albero lento semplice

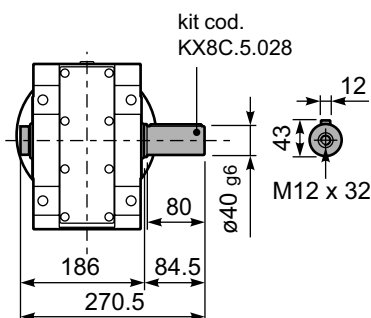

PX83CB... Double shaft
Albero lento bisp.

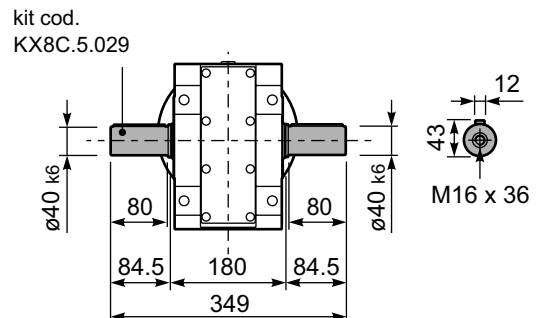

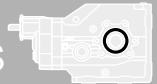

QUICK SELECTION / Selezione veloce

input speed (n_1) = 1400 min⁻¹

Output Speed n_2 [min ⁻¹]	Ratio i	Motor power P_{1M} [kW]	Output torque M_{2M} [Nm]	Service factor f.s.	Nominal power P_{1R} [kW]	Nominal torque M_{2R} [Nm]	Available B5 motor flanges				Available B14 motor flanges			Output Shaft 	Ratios code
							-B	-C	-D	-E	-Q	-R	-T		
							63	71	80	90	71	80	90		
15.3	91.23	1.5	858	1.2	1.7	1000	B				C	C		19132418	01
13.4	104.48	1.5	983	1.0	1.5	1000	B				C	C		19132416	02
11.6	121.10	1.5	1139	0.9	1.3	1000	B				C	C		17132416	03
9.9	140.84	1.1	968	1.0	1.1	1000	B				C	C		17132414	04
8.5	165.32	1.1	1136	0.9	0.96	1000	B				C	C		15132414	05
7.6	184.94	0.75	872	1.1	0.86	1000	B				C	C		19082416	06
7.1	197.34	0.75	930	1.1	0.81	1000	B				C	C		13132414	07
6.5	215.10	0.75	1014	1.0	0.74	1000	B				C	C		19082414	08
6.0	231.60	0.55	805	1.2	0.69	1000	B				C	C		10132416	09
5.6	249.31	0.55	867	1.2	0.64	1000	B				C	C		17082414	10
5.2	269.37	0.55	937	1.1	0.59	1000	B				C	C		10132414	11
4.8	292.64	0.55	1018	1.0	0.54	1000	B				C	C		15082414	12
4.6	302.26	0.55	1051	1.0	0.53	1000	B				C	C		9132416	13
4.0	349.30	0.37	812	1.2	0.46	1000	B				C	C		13082414	14
3.5	399.12	0.37	928	1.1	0.40	1000	B				C	C		7132416	15
2.9	476.80	0.37	1108	0.9	0.33	1000	B				C	C		10082414	16
2.2	622.28	0.25	976	1.0	0.26	1000	B				C	C		9082414	17
1.7	821.70	0.18	985	1.0	0.19	1000	B				C	C		7082414	18

The dynamic efficiency is **0.92** for all ratios

Motor Flanges Available Flange Motore Disponibili
B) Supplied with Reduction Bushing Fornito con Bussola di Riduzione
B) Available on Request without reduction bushing Disponibile a Richiesta senza Bussola di Riduzione
C) Motor Flange Holes Position Posizione Fori Flangia Motore

EN Unit **X84C** is supplied without lubricant and equipped with a breather, level and drain plugs. User can add mineral oil keeping existing plugs. Should the user wish to fill it with synthetic oil, it is recommended to replace the existing plugs with a closed plug.
See table 1 for lubrication and recommended quantity. In table 2 please see possible radial loads and axial loads on the gearbox.

B3	B6	B7	B8	V5	V6	V8
4.25 LT	3.20 LT	2.10 LT	2.60 LT	5.20 LT	2.90 LT	Ask
SHELL Omala S2 GX 460				ENI Blasias 460		

For all details on lubrication and plugs check our website [Per maggiori dettagli su lubrificazione e tappi olio vedi il nostro sito web](#) **tab. 1**

I Il riduttore tipo **X84C** è fornito privo di lubrificazione con tappi di sfiato, livello e scarico olio. L'utente può immettere olio minerale mantenendo i tappi esistenti. Se immetterà olio sintetico, dovrà sostituire i tappi esistenti con altri tipo chiuso.
Tab.1 per oli e quantità consigliati.
Tab.2 carichi radiali e assiali applicabili al riduttore.

D Das Getriebe der Baugröße **X84C** wird ohne Schmiermittel geliefert. Es ist jedoch mit Einfüllschraube, Überdruckventil und Ablassschraube ausgerüstet. Das benötigte mineralische Öl kann über die Einfüllschraube eingefüllt werden. Sollte synthetisches Öl bevorzugt werden, so ist sind das eingebaute Überdruckventil durch eine geschlossenen Schraube zu ersetzen.
In Tabelle 1 ist die Schmiermenge und das empfohlene Schmiermittel angegeben
In Tabelle 2 sind die zulässigen Radial - und Axialbelastungen des Getriebes aufgeführt.

F Le réducteur de type **X84C** est fourni sans lubrification et avec un bouchon de remplissage, de niveau et d'évacuation de l'huile. L'utilisateur peut y verser de l'huile minérale en conservant les bouchons existants.
S'il y versera de l'huile synthétique, il devra substituer les bouchons existants avec d'autres bouchons de type fermé.
Voir tableau 1 concernant les huiles et les quantités conseillées.
Voir tableau 2 concernant les charges radiales et axiales applicables au réducteur

E El reductor tamaño **X84C** se suministra sin lubricante, provisto de tapones de respiración, nivel y descarga de aceite. El usuario puede utilizar aceite mineral, manteniendo los tapones existentes. Si prefiere utilizar aceite sintético deberá sustituir los tapones existentes por tapones ciegos. La prerreducción se suministra con tapones ciegos, lubricado de por vida con aceite sintético.
Ver tabla 1, para cantidades y aceites recomendados. En la tabla 2, se encuentran las cargas radiales y axiales admitidas por el reductor.

RADIAL AND AXIAL LOADS

Output shaft
Albero di uscita

$F_{eq} = FR \cdot \frac{196.5}{X + 156.5}$

n_2	FA	FR	n_2	FA	FR	n_2	FA	FR
300	1700	8500	140	1860	9300	70	2160	10800
250	1760	8800	120	1900	9500	40	2300	11500
200	1800	9000	85	1960	9800	15	2400	12000

On request reinforced bearings to increase loads.
A richiesta cuscinetti rinforzati per aumentare i carichi.

Input shaft
Albero in entrata

n_1	FA	FR
1400	400	2000
900	440	2200
500	440	2200

tab. 2

PX84CC... Basic gearbox
Riduttore base

Gearbox weight
peso riduttore **46.5 kg**

M. flanges	Kit code	øF	A
63B5	K063.4.041	140	327.7
71B5	K063.4.042	160	325.7
80/90B5	K063.4.043	200	327.7
71B14	K063.4.047	105	325.7
80B14	K063.4.046	120	327.7
90B14	K063.4.041	140	327.7

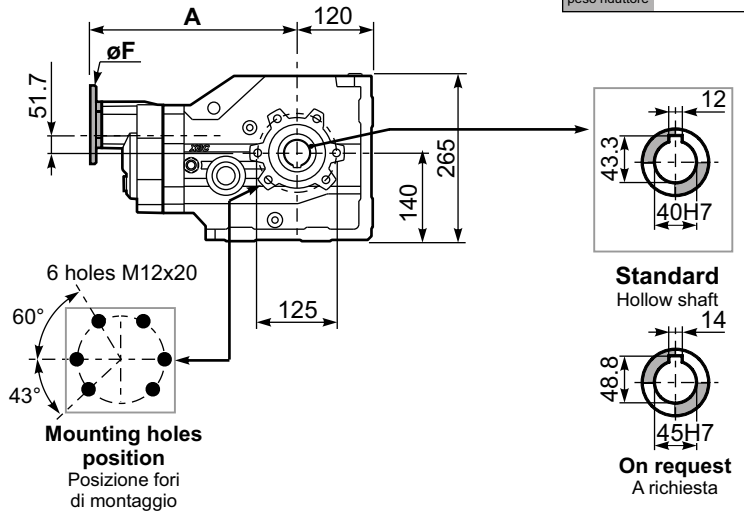
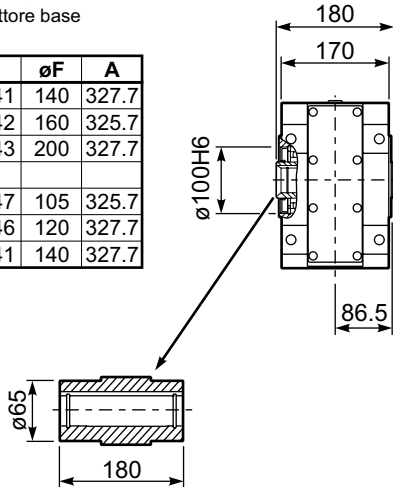

PX84C...FB.. Feet
Piedini

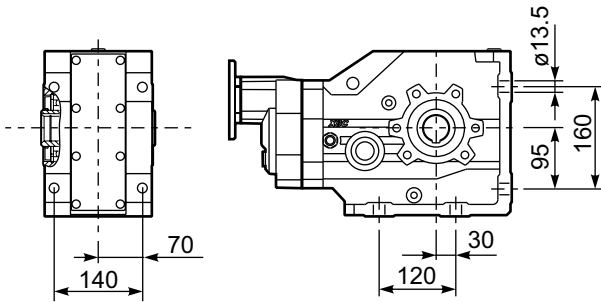

PX84C...-F4.. Output flange
Flangia uscita

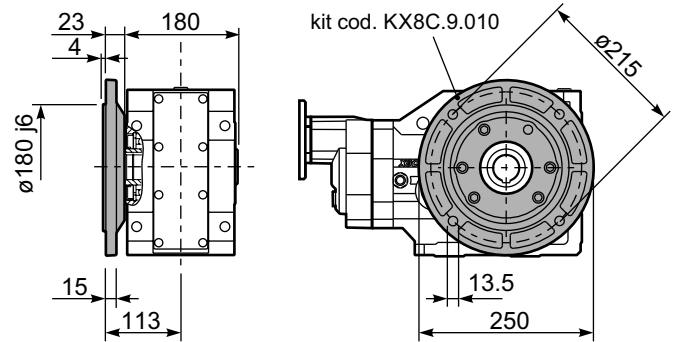

PX84C...BR.. Reaction Arm
Braccio di reazione

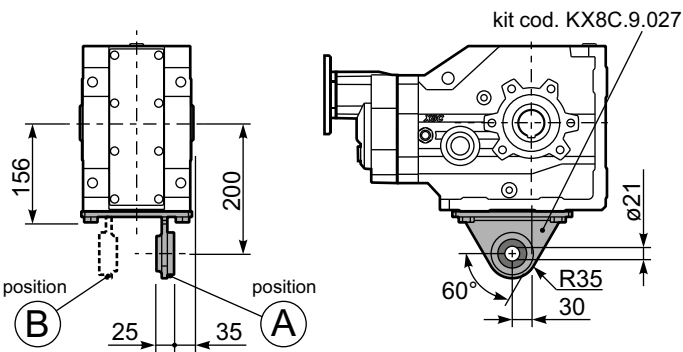

RX84C... Input shaft
Albero in entrata

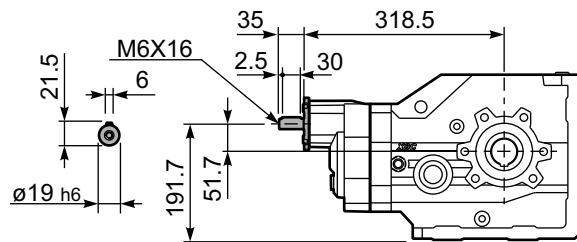

PX84CA... Single shaft
Albero lento semplice

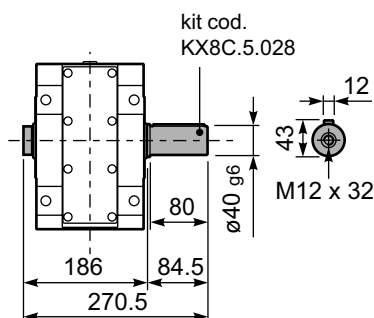

PX84CB... Double shaft
Albero lento bisp.

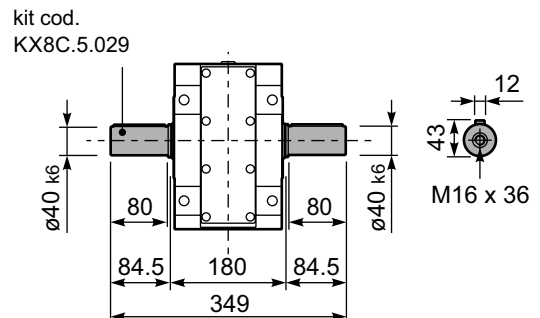

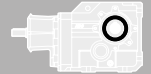

QUICK SELECTION / Selezione veloce

input speed (n₁) = 1400 min⁻¹

Output Speed n ₂ [min ⁻¹]	Ratio i	Motor power P _{1M} [kW]	Output torque M _{2M} [Nm]	Service factor f.s.	Nominal power P _{1R} [kW]	Nominal torque M _{2R} [Nm]	B5 motor flanges				B14 motor flanges		Output Shaft 	Ratios code
							-F	-G	-H	-I	-U	-V		
							100 112	132	160	180	100 112	132		
236	5.94	22	806	1.0	21.0	800						302915	01	
196	7.13	18.5	812	1.0	17.9	820						302913	02	
163	8.58	18.5	977	1.0	17.3	950						302911	03	
125	11.20	15	1033	1.0	13.9	1000						202915	04	
104	13.43	15	1239	1.1	15.7	1350						202913	05	
92	15.15	15	1397	1.0	14.4	1400						162915	06	
87	16.17	15	1492	1.0	14.0	1450						202911	07	
77	18.16	15	1675	0.9	13.3	1550						162913	08	
71	19.70	11	1335	1.2	12.3	1550						132915	09	
64	21.87	11	1482	1.1	11.4	1600						162911	10	
59	23.62	11	1600	1.0	10.6	1600						132913	11	
48.4	28.91	9	1671	1.0	8.6	1600						112913	12	
40.2	34.81	7.5	1618	1.0	7.2	1600						112911	13	
33.5	41.81	5.5	1436	1.1	6.0	1600						82913	14	
27.8	50.34	5.5	1729	0.9	5.0	1600						82911	15	

The dynamic efficiency is **0.94** for all ratios

- Motor Flanges Available Flange Motore Disponibili
- B) Supplied with Reduction Bushing Fornito con Bussola di Riduzione
- B) Available on Request without reduction bushing Disponibile a Richiesta senza Bussola di Riduzione
- C) Motor Flange Holes Position Posizione Fori Flangia Motore

EN Unit **X93C** is supplied without lubricant and equipped with a breather, level and drain plugs. User can add mineral oil keeping existing plugs. Should the user wish to fill it with synthetic oil, it is recommended to replace the existing plugs with a closed plug. See table 1 for lubrication and recommended quantity. In table 2 please see possible radial loads and axial loads on the gearbox.

I Il riduttore tipo **X93C** è fornito privo di lubrificazione con tappi di sfiato, livello e scarico olio. L'utente può immettere olio minerale mantenendo i tappi esistenti. Se immetterà olio sintetico, dovrà sostituire i tappi esistenti con altri tipo chiuso. Tab.1 per oli e quantità consigliati. Tab.2 carichi radiali e assiali applicabili al riduttore.

D Das Getriebe der Baugröße **X93C** wird ohne Schmiermittel geliefert. Es ist jedoch mit Einfüllschraube, Überdruckventil und Ablassschraube ausgerüstet. Das benötigte mineralische Öl kann über die Einfüllschraube eingefüllt werden. Sollte synthetisches Öl bevorzugt werden, so ist sind das eingebaute Überdruckventil durch eine geschlossenen Schraube zu ersetzen. In Tabelle 1 ist die Schmiermenge und das empfohlene Schmiermittel angegeben. In Tabelle 2 sind die zulässigen Radial - und Axialbelastungen des Getriebes aufgeführt.

F Le réducteur de type **X93C** est fourni sans lubrification et avec un bouchon de remplissage, de niveau et d'évacuation de l'huile. L'utilisateur peut y verser de l'huile minérale en conservant les bouchons existants. S'il y versera de l'huile synthétique, il devra substituer les bouchons existants avec d'autres bouchons de type fermé. Voir tableau 1 concernant les huiles et les quantités conseillées. Voir tableau 2 concernant les charges radiales et axiales applicables au réducteur

E El reductor tamaño **X93C** se suministra sin lubricante, provisto de tapones de respiración, nivel y descarga de aceite. El usuario puede utilizar aceite mineral, manteniendo los tapones existentes. Si prefiere utilizar aceite sintético deberá sustituir los tapones existentes por tapones ciegos. La prerreducción se suministra con tapones ciegos, lubricado de por vida con aceite sintético. Ver tabla 1, para cantidades y aceites recomendados. En la tabla 2, se encuentran las cargas radiales y axiales admitidas por el reductor.

Standard supplied	For these mounting position specify in the order or add oil Per queste posizioni specificare in fase d'ordine o aggiungere olio					
B3	B6	B7	B8	V5	V6	V8
4.20 LT	3.60 LT	4.40 LT	5.10 LT	6.90 LT	5.00 LT	Ask
SHELL Omala S2 GX 460				ENI Blasias 460		

For all details on lubrication and plugs check our website [tab. 1](#)
Per maggiori dettagli su lubrificazione e tappi olio vedi il nostro sito web

RADIAL AND AXIAL LOADS

Output shaft
Albero di uscita

$$F_{eq} = F_R \cdot \frac{218}{X+168}$$

n ₂	FA	FR	n ₂	FA	FR	n ₂	FA	FR
300	1800	9000	140	2700	13500	70	3020	15100
250	2400	12000	120	2800	14000	40	3200	16000
200	2600	13000	85	2900	14500	15	3500	17500

Input shaft
Albero in entrata

n ₁	FA	FR
1400	700	3500
900	840	4200
500	900	4500

tab. 2

PX93CC... Basic Gearbox
Riduttore base

Gearbox weight
peso riduttore **75.0 kg**

M. flanges	Kit code	øF	A
100/112B5	K023.4.043	250	342.5
132B5	KC51.4.043C	300	364
160/180B5	KC86.4.0.43	350	396
100/112B14	K085.4.047	160	342.5
132B14	KC51.4.041C	200	364

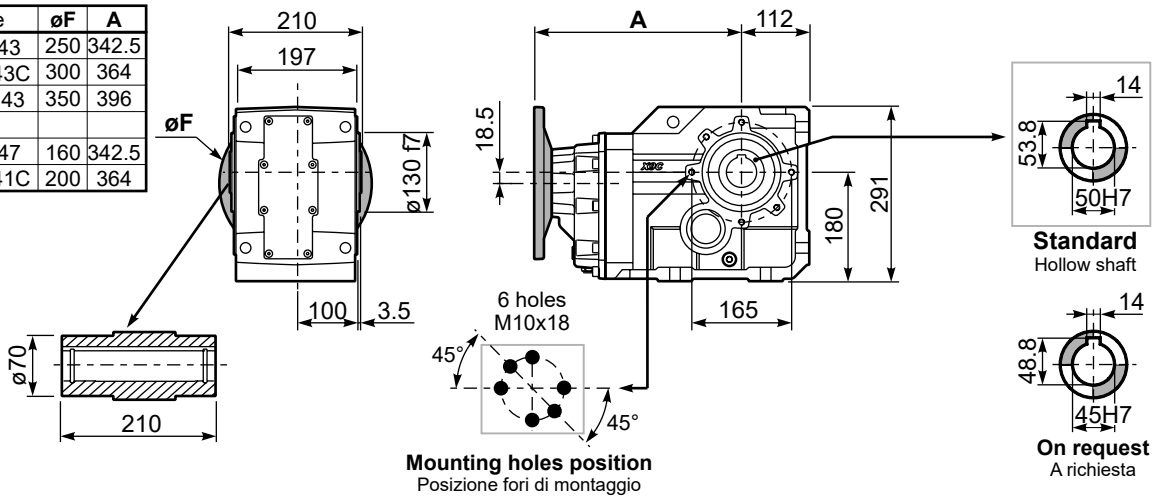

PX93C...FB.. Feet
Piedini

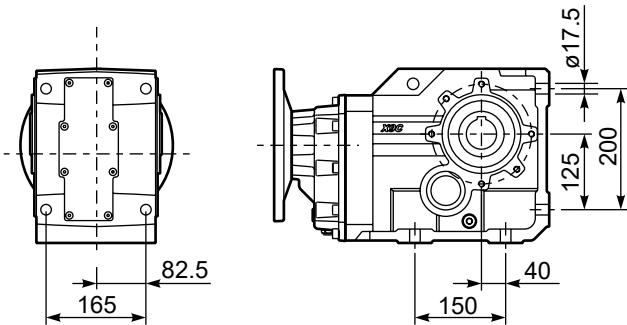

PX93C...-FC.. Output flange
Flangia uscita

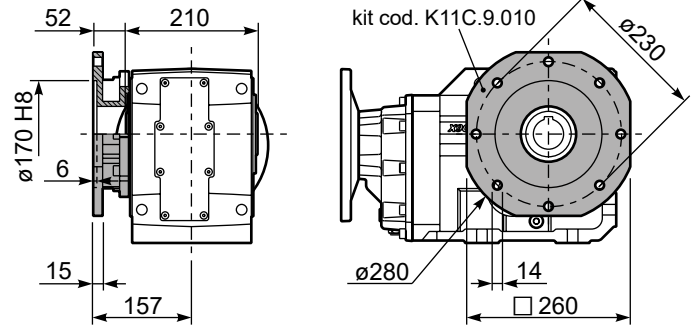

PX93C...-FL.. Output flange
Flangia uscita

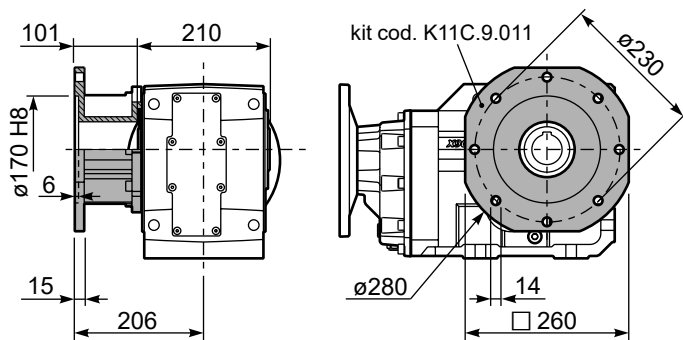

PX93C...BR.. Reaction Arm
Braccio di reazione

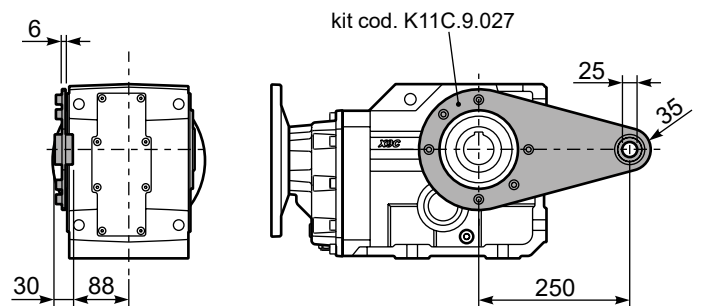

RX93C... Input shaft
Albero in entrata

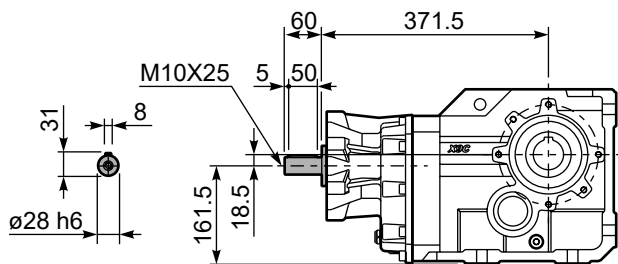

PX93CA... Single shaft
Albero lento semplice

PX93CB... Double shaft
Albero lento bisp.

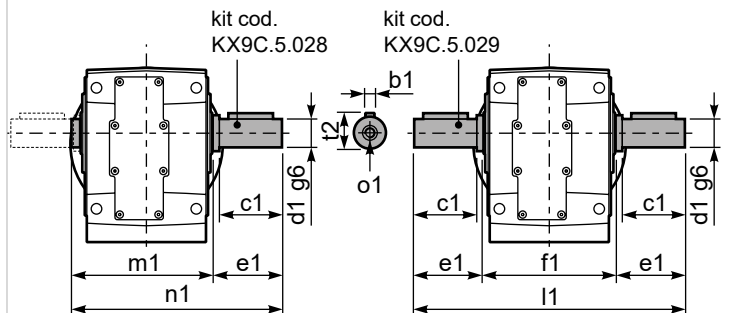

	b1	c1	d1	e1	f1	l1	m1	n1	t2	o1
Standard	14	100	50	105	210	420	218	323	53.5	M16
-	-	-	-	-	-	-	-	-	-	-



QUICK SELECTION / Selezione veloce

input speed (n_1) = 1400 min⁻¹

Output Speed n_2 [min ⁻¹]	Ratio i	Motor power P_{1M} [kW]	Output torque M_{2M} [Nm]	Service factor $f.s.$	Nominal power P_{1R} [kW]	Nominal torque M_{2R} [Nm]	Available B5 motor flanges					Available B14 motor flanges				Output Shaft 	Ratios code
							-C	-D	-E	-F	-G	-R	-T	-U	-V		
							71	80	90	100 112	132	80	90	100 112	132		
45.6	30.70	7.5	1399	1.1	8.3	1600	B									30132913	01
37.9	36.97	7.5	1685	0.9	6.9	1600	B									30132911	02
29.0	48.26	5.5	1625	1.0	5.3	1600	B									20132915	03
24.2	57.86	4	1425	1.1	4.4	1600	B									20132913	04
21.5	65.24	4	1607	1.0	3.9	1600	B									16132915	05
20.1	69.68	4	1716	1.0	3.8	1650	B									20132911	06
17.9	78.23	3	1450	1.1	3.4	1650	B									16132913	07
16.5	84.85	3	1573	1.0	3.0	1600	B									13132915	08
14.9	94.20	3	1747	0.9	2.8	1650	B									16132911	09
13.8	101.74	3	1886	0.9	2.6	1650	B									13132913	10
11.4	122.51	2.2	1672	1.0	2.1	1650	B									13132911	11
9.3	149.95	1.5	1411	1.2	1.8	1650	B									11132911	12
7.8	180.09	1.5	1694	1.0	1.5	1650	B									8132913	13
6.8	206.81	1.1	1421	1.1	1.2	1600	B									6132915	14
6.5	216.85	1.1	1490	1.1	1.2	1650	B									8132911	15
5.6	247.99	1.1	1704	1.0	1.1	1650	B									6132913	16
4.7	298.61	0.75	1407	1.2	0.88	1650	B									6132911	17

The dynamic efficiency is **0.92** for all ratios

- Motor Flanges Available Flange Motore Disponibili
- B) Supplied with Reduction Bushing Fornito con Bussola di Riduzione
- B) Available on Request without reduction bushing Disponibile a Richiesta senza Bussola di Riduzione
- C) Motor Flange Holes Position Posizione Fori Flangia Motore

EN Unit **X94C** is supplied without lubricant and equipped with a breather, level and drain plugs. User can add mineral oil keeping existing plugs. Should the user wish to fill it with synthetic oil, it is recommended to replace the existing plugs with a closed plug. See table 1 for lubrication and recommended quantity. In table 2 please see possible radial loads and axial loads on the gearbox.

I Il riduttore tipo **X94C** è fornito privo di lubrificazione con tappi di sfiato, livello e scarico olio. L'utente può immettere olio minerale mantenendo i tappi esistenti. Se immetterà olio sintetico, dovrà sostituire i tappi esistenti con altri tipo chiuso. Tab.1 per oli e quantità consigliati. Tab.2 carichi radiali e assiali applicabili al riduttore.

D Das Getriebe der Baugröße **X94C** wird ohne Schmiermittel geliefert. Es ist jedoch mit Einfüllschraube, Überdruckventil und Ablassschraube ausgerüstet. Das benötigte mineralische Öl kann über die Einfüllschraube eingefüllt werden. Sollte synthetisches Öl bevorzugt werden, so ist sind das eingebaute Überdruckventil durch eine geschlossenen Schraube zu ersetzen. In Tabelle 1 ist die Schmiermenge und das empfohlene Schmiermittel angegeben. In Tabelle 2 sind die zulässigen Radial - und Axialbelastungen des Getriebes aufgeführt.

F Le réducteur de type **X94C** est fourni sans lubrification et avec un bouchon de remplissage, de niveau et d'évacuation de l'huile. L'utilisateur peut y verser de l'huile minérale en conservant les bouchons existants. S'il y versera de l'huile synthétique, il devra substituer les bouchons existants avec d'autres bouchons de type fermé. Voir tableau 1 concernant les huiles et les quantités conseillées. Voir tableau 2 concernant les charges radiales et axiales applicables au réducteur

E El reductor tamaño **X94C** se suministra sin lubricante, provisto de tapones de respiración, nivel y descarga de aceite. El usuario puede utilizar aceite mineral, manteniendo los tapones existentes. Si prefiere utilizar aceite sintético deberá sustituir los tapones existentes por tapones ciegos. La prerreducción se suministra con tapones ciegos, lubricado de por vida con aceite sintético. Ver tabla 1, para cantidades y aceites recomendados. En la tabla 2, se encuentran las cargas radiales y axiales admitidas por el reductor.

Standard supplied	For these mounting position specify in the order or add oil Per queste posizioni specificare in fase d'ordine o aggiungere olio					
B3	B6	B7	B8	V5	V6	V8
4.50 LT	3.80 LT	4.50 LT	5.30 LT	7.60 LT	5.30 LT	Ask
SHELL Omala S2 GX 460				ENI Blasias 460		

For all details on lubrication and plugs check our website [tab. 1](#)
Per maggiori dettagli su lubrificazione e tappi olio vedi il nostro sito web

RADIAL AND AXIAL LOADS

Output shaft
Albero di uscita

$F_{eq} = FR \cdot \frac{218}{X+168}$

n_2	FA	FR	n_2	FA	FR	n_2	FA	FR
300	1800	9000	140	2700	13500	70	3020	15100
250	2400	12000	120	2800	14000	40	3200	16000
200	2600	13000	85	2900	14500	15	3500	17500

Input shaft
Albero in entrata

n_1	FA	FR
1400	450	2250
900	500	2500
500	600	3000

tab. 2

PX94CC... Basic Gearbox
Riduttore base

Gearbox weight **68.5 kg**
peso riduttore

M. flanges	Kit code	øF	A
71B5	K023.4.041	160	336
80/90B5	K023.4.042	200	338
100/112B5	K023.4.043	250	347
132B5	KC51.4.043	300	368
80B14	K085.4.046	120	338
90B14	K085.4.045	140	338
100/112B14	K085.4.047	160	347
132B14	KC51.4.041	200	368

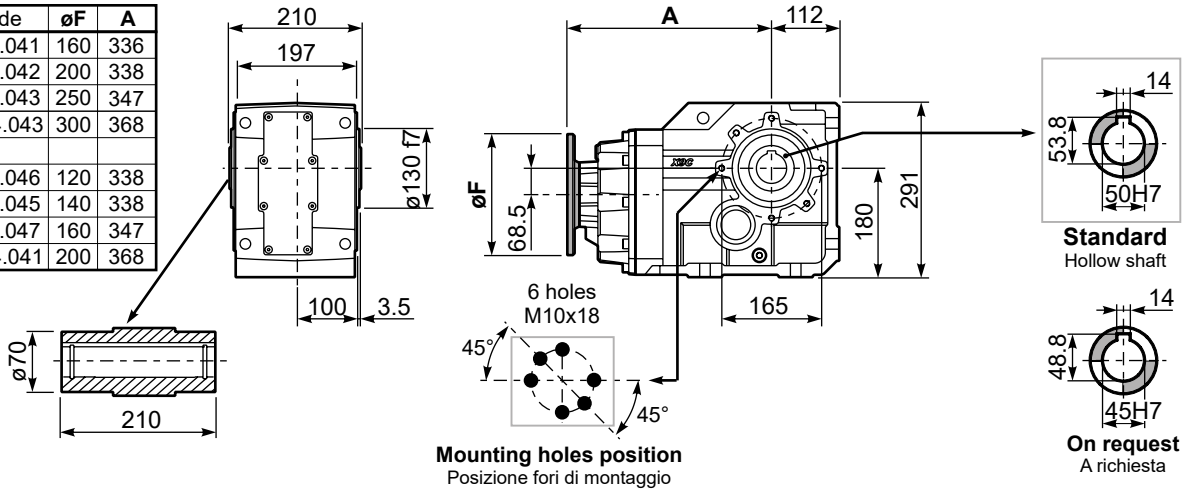

PX94C...FB.. Feet
Piedini

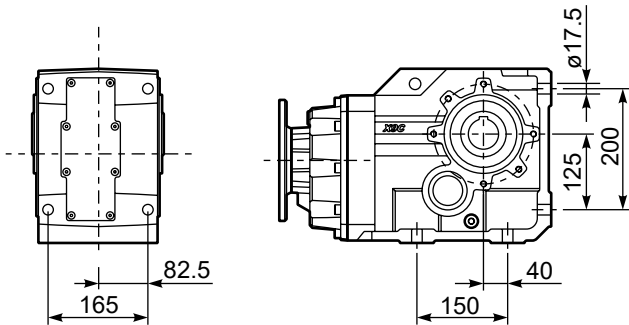

PX94C...-FC.. Output flange
Flangia uscita

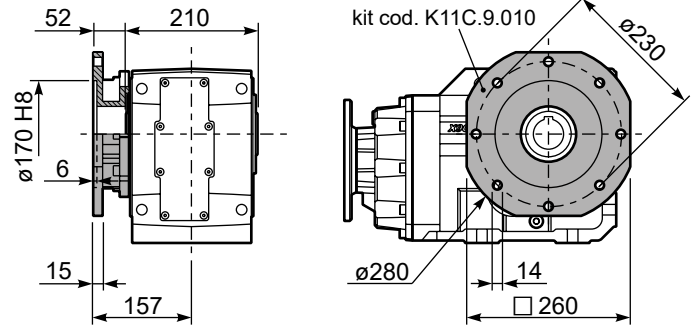

PX94C...-FL.. Output flange
Flangia uscita

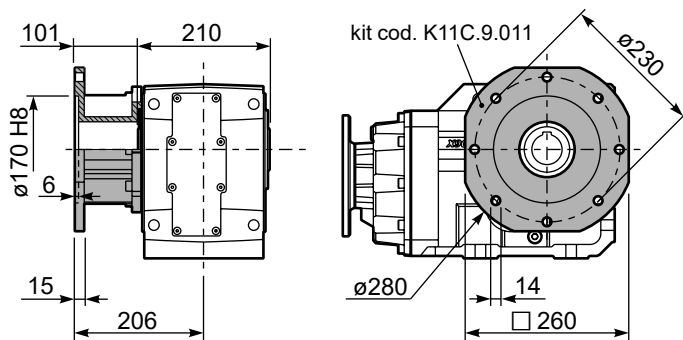

PX94C...BR.. Reaction Arm
Braccio di reazione

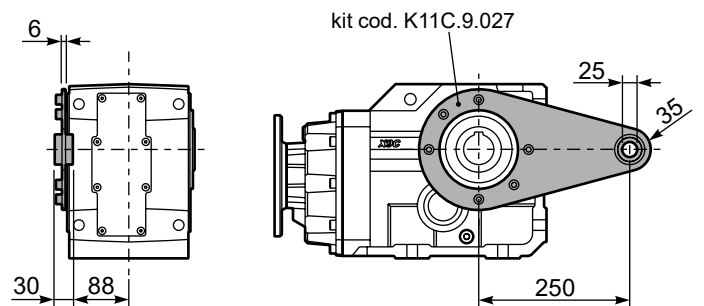

RX94C... Input shaft
Albero in entrata

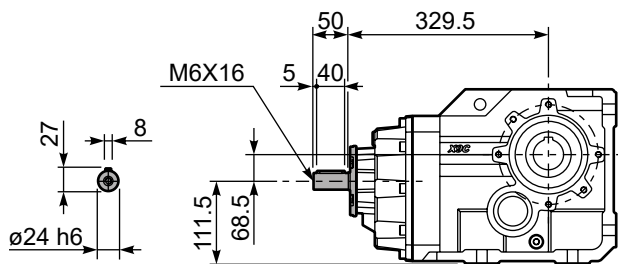

PX94CA... Single shaft
Albero lento semplice

PX94CB... Double shaft
Albero lento bisp.

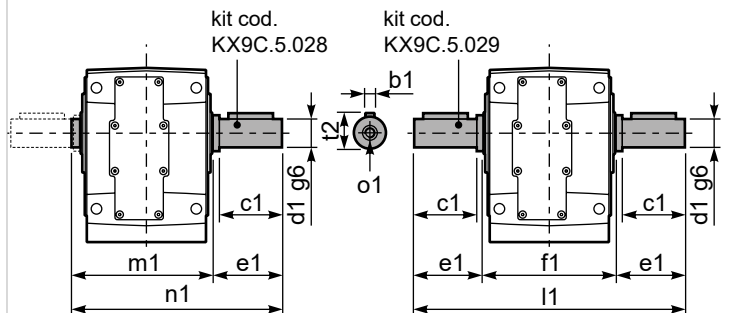

	b1	c1	d1	e1	f1	l1	m1	n1	t2	o1
Standard	14	100	50	105	210	420	218	323	53.5	M16
-	-	-	-	-	-	-	-	-	-	-

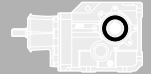

QUICK SELECTION / Selezione veloce

input speed (n_1) = 1400 min⁻¹

Output Speed n_2 [min ⁻¹]	Ratio i	Motor power P_{1M} [kW]	Output torque M_{2M} [Nm]	Service factor $f.s.$	Nominal power P_{1R} [kW]	Nominal torque M_{2R} [Nm]	B5 motor flanges				B14 motor flanges				Output Shaft 	Ratios code
							-G	-H	-I	-L	-	-	-	-		
							132	160	180	200	-	-	-	-		
219	6.39	30	1180	1.1	31.7	1300								392914	01	
200	7.00	30	1292	1.1	31.2	1400								392913	02	
164	8.55	30	1578	1.0	27.4	1500								392911	03	
140	10.01	22	1357	1.2	24.9	1600								302914	04	
128	10.97	22	1486	1.1	24.2	1700								302913	05	
105	13.39	22	1815	1.2	24.5	2100								302911	06	
89	15.71	22	2130	1.0	21.8	2200								222914	07	
81	17.21	22	2333	1.0	20.8	2300								222913	08	
67	21.02	18.5	2394	1.0	17.8	2400								222911	09	
59	23.73	18.5	2703	1.0	17.1	2600								162914	10	
54	25.99	18.5	2960	0.9	16.8	2800								162913	11	
50	27.93	15	2576	1.1	16.2	2900								142914	12	
45.8	30.59	15	2822	1.0	14.8	2900								142913	13	
44.1	31.74	15	2928	1.0	14.2	2900								162911	14	
37.5	37.36	11	2532	1.1	12.1	2900								142911	15	
33.8	41.37	11	2804	1.0	10.9	2900								102914	16	
30.9	45.31	9	2618	1.1	10.0	2900								102913	17	
25.3	55.33	7.5	2573	1.2	8.5	3000								102911	18	

The dynamic efficiency is **0.94** for all ratios

Motor Flanges Available
Flange Motore Disponibili

B) Supplied with Reduction Bushing
Fornito con Bussola di Riduzione

B) Available on Request without reduction bushing
Disponibile a Richiesta senza Bussola di Riduzione

C) Motor Flange Holes Position
Posizione Fori Flangia Motore

EN Unit **X103** is supplied without lubricant and equipped with a breather, level and drain plugs. User can add mineral oil keeping existing plugs. Should the user wish to fill it with synthetic oil, it is recommended to replace the existing plugs with a closed plug.
See table 1 for lubrication and recommended quantity. In table 2 please see possible radial loads and axial loads on the gearbox.

I Il riduttore tipo **X103** è fornito privo di lubrificazione con tappi di sfio, livello e scarico olio. L'utente può immettere olio minerale mantenendo i tappi esistenti. Se immetterà olio sintetico, dovrà sostituire i tappi esistenti con altri tipo chiuso.
Tab.1 per oli e quantità consigliati.
Tab.2 carichi radiali e assiali applicabili al riduttore.

D Das Getriebe der Baugröße **X103** wird ohne Schmiermittel geliefert. Es ist jedoch mit Einfüllschraube, Überdruckventil und Ablassschraube ausgerüstet. Das benötigte mineralische Öl kann über die Einfüllschraube eingefüllt werden. Sollte synthetisches Öl bevorzugt werden, so ist sind das eingebaute Überdruckventil durch eine geschlossenen Schraube zu ersetzen.
In Tabelle 1 ist die Schmiermenge und das empfohlene Schmiermittel angegeben
In Tabelle 2 sind die zulässigen Radial - und Axialbelastungen des Getriebes aufgeführt.

F Le réducteur de type **X103** est fourni sans lubrification et avec un bouchon de remplissage, de niveau et d'évacuation de l'huile. L'utilisateur peut y verser de l'huile minérale en conservant les bouchons existants. S'il y versera de l'huile synthétique, il devra substituer les bouchons existants avec d'autres bouchons de type fermé.
Voir tableau 1 concernant les huiles et les quantités conseillées.
Voir tableau 2 concernant les charges radiales et axiales applicables au réducteur

E El reductor tamaño **X103** se suministra sin lubricante, provisto de tapones de respiración, nivel y descarga de aceite. El usuario puede utilizar aceite mineral, manteniendo los tapones existentes. Si prefiere utilizar aceite sintético deberá sustituir los tapones existentes por tapones ciegos. La prerreducción se suministra con tapones ciegos, lubricado de por vida con aceite sintético.
Ver tabla 1, para cantidades y aceites recomendados.
En la tabla 2, se encuentran las cargas radiales y axiales admitidas por el reductor.

Standard supplied	For these mounting position specify in the order or add oil Per queste posizioni specificare in fase d'ordine o aggiungere olio					
B3	B6	B7	B8	V5	V6	V8
11.50 LT	5.50 LT	10.50 LT	7.50 LT	13.50 LT	9.50 LT	Ask
SHELL Omala S2 GX 460				ENI Blasias 460		

For all details on lubrication and plugs check our website **tab. 1**
Per maggiori dettagli su lubrificazione e tappi olio vedi il nostro sito web

RADIAL AND AXIAL LOADS

Output shaft
Albero di uscita

$F_{eq} = FR \cdot \frac{253}{X+193}$

n_2	FA	FR	n_2	FA	FR	n_2	FA	FR
300	2000	10000	140	2800	14000	70	3500	17500
250	2500	12500	120	3000	15000	40	4200	21000
200	2700	13500	85	3200	16000	15	5400	27000

Input shaft
Albero in entrata

n_1	FA	FR
1400	1120	5600
900	1220	6100
500	1300	6500

tab. 2

PX103C... Basic Gearbox
Riduttore base

Gearbox weight **125 kg**
peso riduttore

M. flanges	Kit code	øF	A
132B5	KC110.9.052	300	486.5
160B5	KC110.9.053	350	511.5
180B5	KC110.9.053 B	350	511.5
200B5	KC110.9.054	400	511.5

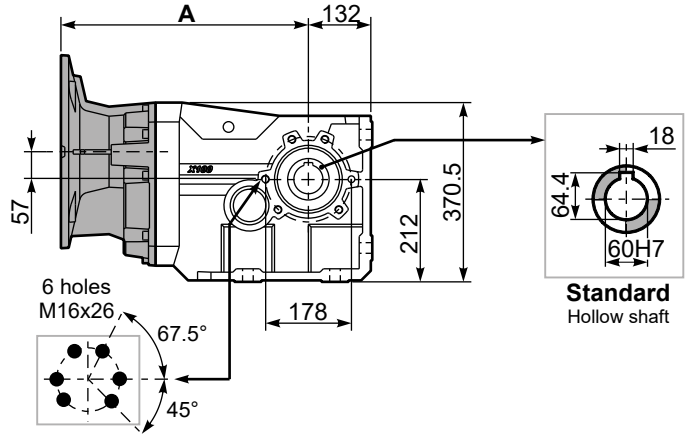
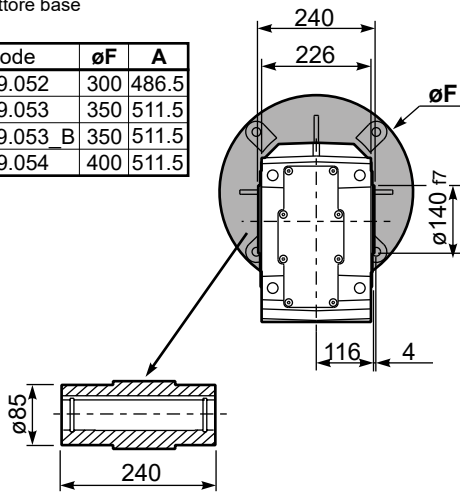

Mounting holes position
Posizione fori di montaggio

Standard
Hollow shaft

PX103...FB.. Feet
Piedini

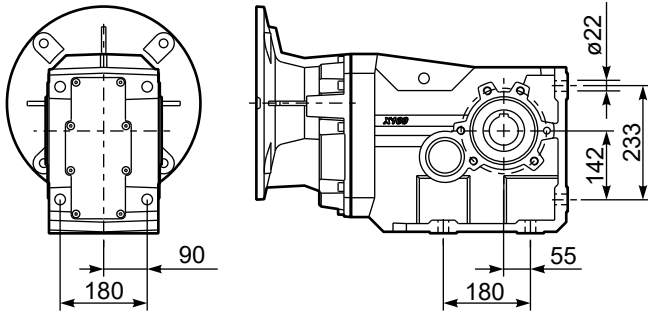

PX103...-F6.. Output flange
Flangia uscita

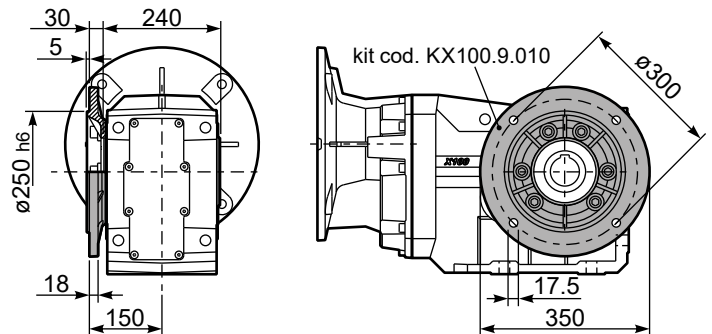

PX103...BR.. Reaction Arm
Braccio di reazione

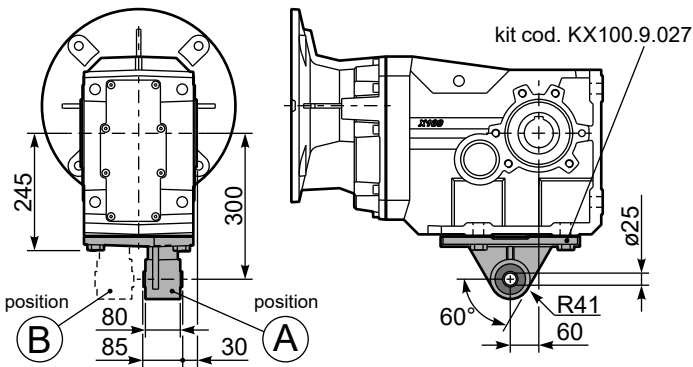

RX103... Input shaft
Albero in entrata

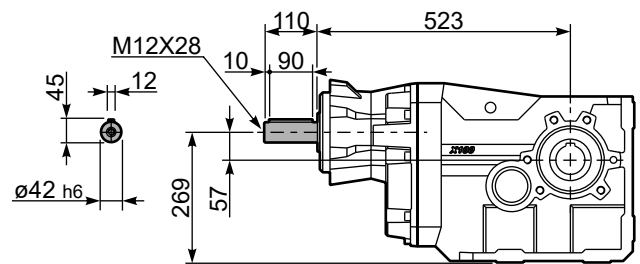

PX103A... Single shaft
Albero lento semplice

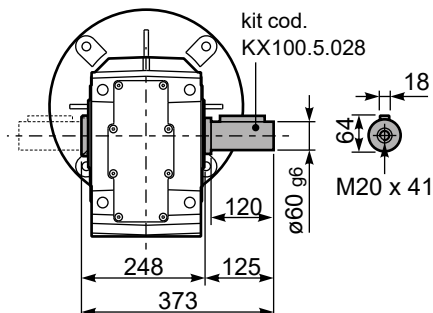

PX103B... Double shaft
Albero lento bisp.

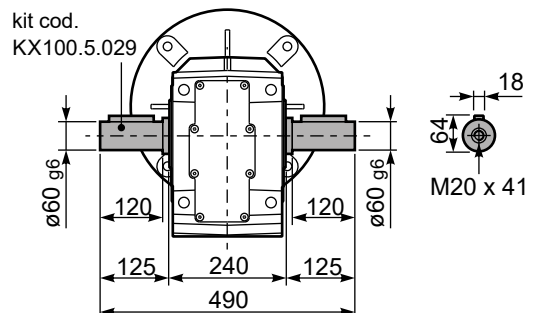

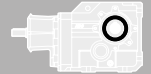

QUICK SELECTION / Selezione veloce

input speed (n_1) = 1400 min⁻¹

Output Speed n_2 [min ⁻¹]	Ratio i	Motor power P_{1M} [kW]	Output torque M_{2M} [Nm]	Service factor f.s.	Nominal power P_{1R} [kW]	Nominal torque M_{2R} [Nm]	Available B5 motor flanges		B14 motor flanges			Output Shaft 	Ratios code
							-F	-G	-U	-V			
							100 112	132	100 112	132			
28.8	48.57	9	2750	1.1	9.5	2900					30142911	01	
20.5	68.43	7.5	3118	1.0	7.0	3000					20142914	02	
18.7	74.95	5.5	2523	1.2	6.4	3000					20142913	03	
15.1	92.53	5.5	3115	1.0	5.2	3000					16142914	04	
13.8	101.33	4	2496	1.2	4.7	3000					16142913	05	
11.6	120.33	4	2963	1.0	4.0	3000					13142914	06	
11.3	123.75	4	3048	1.0	3.9	3000					16142911	07	
10.6	131.78	4	3245	0.9	3.6	3000					13142913	08	
9.5	147.28	3	2731	1.1	3.2	3000					11142914	09	
8.7	161.30	3	2990	1.0	3.0	3000					11142913	10	
7.1	196.98	2.2	2689	1.1	2.4	3000					11142911	11	
6.6	212.99	2.2	2907	1.0	2.2	3000					8142914	12	
6.0	233.26	2.2	3184	0.9	2.0	3000					8142913	13	
4.9	284.86	2.2	3889	0.8	1.7	3000					8142911	14	

The dynamic efficiency is **0.92** for all ratios

Motor Flanges Available
Flange Motore Disponibili

B) Supplied with Reduction Bushing
Fornito con Bussola di Riduzione

B) Available on Request without reduction bushing
Disponibile a Richiesta senza Bussola di Riduzione

C) Motor Flange Holes Position
Posizione Fori Flangia Motore

EN Unit **X104** is supplied without lubricant and equipped with a breather, level and drain plugs. User can add mineral oil keeping existing plugs. Should the user wish to fill it with synthetic oil, it is recommended to replace the existing plugs with a closed plug. See table 1 for lubrication and recommended quantity. In table 2 please see possible radial loads and axial loads on the gearbox.

I Il riduttore tipo **X104** è fornito privo di lubrificazione con tappi di sfiato, livello e scarico olio. L'utente può immettere olio minerale mantenendo i tappi esistenti. Se immetterà olio sintetico, dovrà sostituire i tappi esistenti con altri tipo chiuso. Tab.1 per oli e quantità consigliati. Tab.2 carichi radiali e assiali applicabili al riduttore.

D Das Getriebe der Baugröße **X104** wird ohne Schmiermittel geliefert. Es ist jedoch mit Einfüllschraube, Überdruckventil und Ablassschraube ausgerüstet. Das benötigte mineralische Öl kann über die Einfüllschraube eingefüllt werden. Sollte synthetisches Öl bevorzugt werden, so ist sind das eingebaute Überdruckventil durch eine geschlossenen Schraube zu ersetzen. In Tabelle 1 ist die Schmiermenge und das empfohlene Schmiermittel angegeben. In Tabelle 2 sind die zulässigen Radial - und Axialbelastungen des Getriebes aufgeführt.

F Le réducteur de type **X104** est fourni sans lubrification et avec un bouchon de remplissage, de niveau et d'évacuation de l'huile. L'utilisateur peut y verser de l'huile minérale en conservant les bouchons existants. S'il y versera de l'huile synthétique, il devra substituer les bouchons existants avec d'autres bouchons de type fermé. Voir tableau 1 concernant les huiles et les quantités conseillées. Voir tableau 2 concernant les charges radiales et axiales applicables au réducteur

E El reductor tamaño **X104** se suministra sin lubricante, provisto de tapones de respiración, nivel y descarga de aceite. El usuario puede utilizar aceite mineral, manteniendo los tapones existentes. Si prefiere utilizar aceite sintético deberá sustituir los tapones existentes por tapones ciegos. La prerreducción se suministra con tapones ciegos, lubricado de por vida con aceite sintético. Ver tabla 1, para cantidades y aceites recomendados. En la tabla 2, se encuentran las cargas radiales y axiales admitidas por el reductor.

Standard supplied	For these mounting position specify in the order or add oil					
	Per queste posizioni specificare in fase d'ordine o aggiungere olio					
B3	B6	B7	B8	V5	V6	V8
12.00 LT	6.00 LT	11.50 LT	8.00 LT	14.50 LT	11.00 LT	Ask
SHELL Omala S2 GX 460			ENI Blasias 460			

For all details on lubrication and plugs check our website **tab. 1**
Per maggiori dettagli su lubrificazione e tappi olio vedi il nostro sito web

RADIAL AND AXIAL LOADS								
Output shaft Albero di uscita			$F_{eq} = FR \cdot \frac{253}{X+193}$					
n_2	FA	FR	n_2	FA	FR	n_2	FA	FR
300	2000	10000	140	2800	14000	70	3500	17500
250	2500	12500	120	3000	15000	40	4200	21000
200	2700	13500	85	3200	16000	15	5400	27000
Input shaft Albero in entrata								
n_1	FA	FR						
1400	700	3500						
900	840	4200						
500	900	4500						

tab. 2

PX104C... Basic Gearbox
Riduttore base

Gearbox weight
peso riduttore **118 kg**

M. flanges	Kit code	øF	A
100/112B5	K023.4.043	250	479
132B5	KC51.4.043C	300	500.5
100/112B14	K085.4.047	160	479
132B14	KC51.4.041C	200	500.5

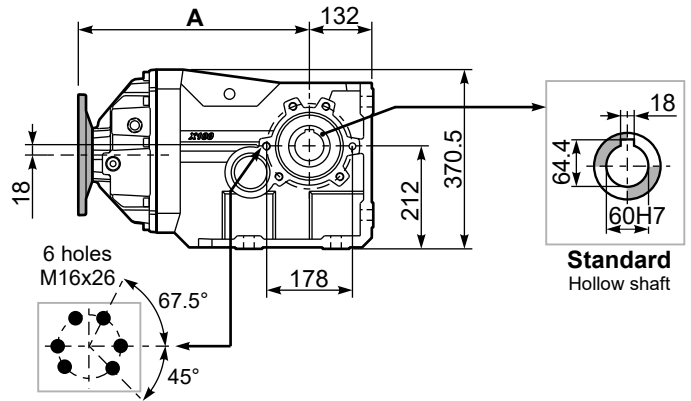
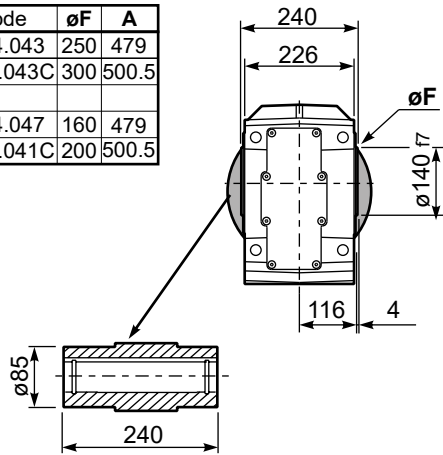

Mounting holes position
Posizione fori di montaggio

PX104...FB.. Feet
Piedini

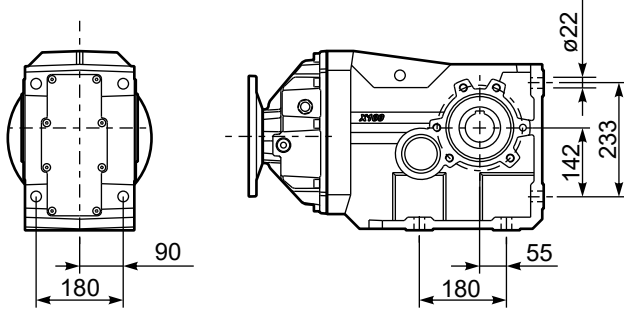

PX104...-F6.. Output flange
Flangia uscita

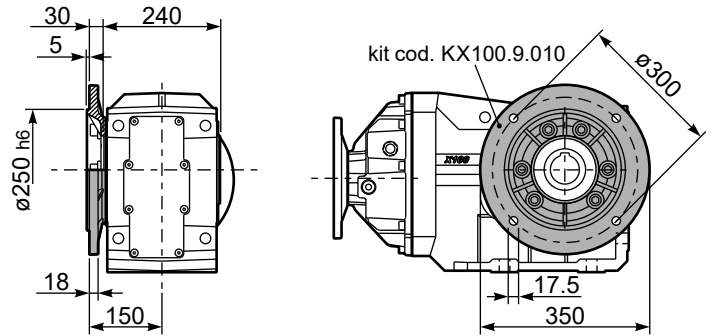

PX104...BR.. Reaction Arm
Braccio di reazione

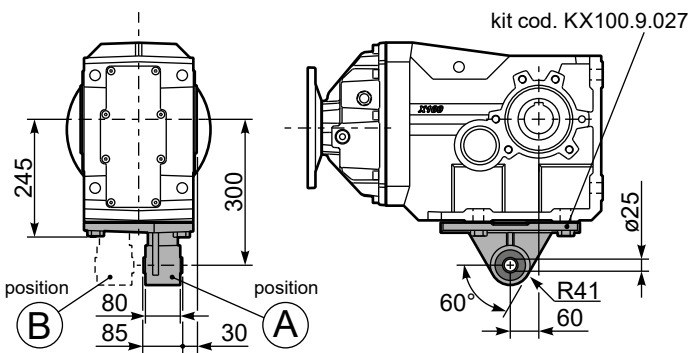

RX104... Input shaft
Albero in entrata

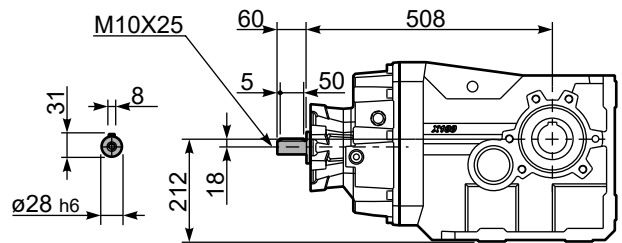

PX104A... Single shaft
Albero lento semplice

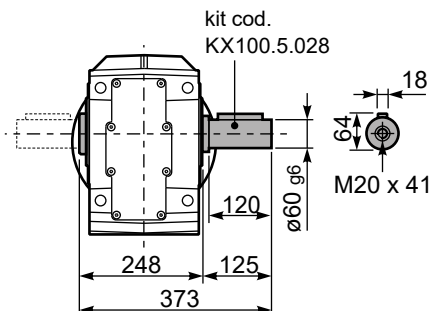

PX104B... Double shaft
Albero lento bisp.

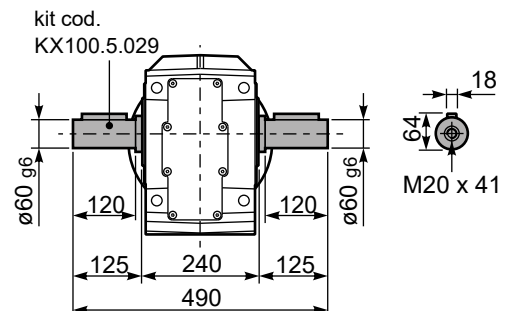

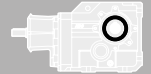

QUICK SELECTION / Selezione veloce

input speed (n_1) = 1400 min⁻¹

Output Speed n_2 [min ⁻¹]	Ratio i	Motor power P_{1M} [kW]	Output torque M_{2M} [Nm]	Service factor $f.s.$	Nominal power P_{1R} [kW]	Nominal torque M_{2R} [Nm]	B5 motor flanges					B14 motor flanges			Output Shaft 	Ratios code
							-G	-H	-I	-L	CA	-	-	-		
							132	160	180	200	225	-	-	-		
219	6.39	45	1757	1.4	61.0	2500								392914	01	
200	7.00	45	1925	1.4	59.0	2650								392913	02	
164	8.55	45	2350	1.2	51.1	2800								392911	03	
140	10.01	45	2752	1.2	49.8	3200								302914	04	
128	10.97	45	3014	1.1	45.5	3200								302913	05	
105	13.39	37	3025	1.1	39.6	3400								302911	06	
89	15.71	37	3550	1.0	34.7	3500								222914	07	
81	17.21	37	3888	1.0	33.5	3700								222913	08	
67	21.02	30	3877	1.0	29.7	4000								222911	09	
59	23.73	30	4378	0.9	26.9	4100								162914	10	
54	25.99	22	3523	1.2	25.8	4300								162913	11	
50	27.93	22	3786	1.1	24.0	4300								142914	12	
45.8	30.59	22	4146	1.1	22.9	4500								142913	13	
44.1	31.74	22	4302	1.0	22.1	4500								162911	14	
37.5	37.36	18.5	4255	1.1	18.8	4500								142911	15	
33.8	41.37	18.5	4712	1.0	17.0	4500								102914	16	
30.9	45.31	15	4179	1.1	15.5	4500								102913	17	
25.3	55.33	11	3750	1.2	12.7	4500								102911	18	

The dynamic efficiency is **0.94** for all ratios

- Motor Flanges Available
Flange Motore Disponibili
- B) Supplied with Reduction Bushing
Fornito con Bussola di Riduzione
- B) Available on Request without reduction bushing
Disponibile a Richiesta senza Bussola di Riduzione
- C) Motor Flange Holes Position
Posizione Fori Flangia Motore

EN Unit X113 is supplied without lubricant and equipped with a breather, level and drain plugs. User can add mineral oil keeping existing plugs. Should the user wish to fill it with synthetic oil, it is recommended to replace the existing plugs with a closed plug.
See table 1 for lubrication and recommended quantity. In table 2 please see possible radial loads and axial loads on the gearbox.

I Il riduttore tipo X113 è fornito privo di lubrificazione con tappi di sfianto, livello e scarico olio. L'utente può immettere olio minerale mantenendo i tappi esistenti. Se immetterà olio sintetico, dovrà sostituire i tappi esistenti con altri tipo chiuso.
Tab.1 per oli e quantità consigliati.
Tab.2 carichi radiali e assiali applicabili al riduttore.

D Das Getriebe der Baugröße X113 wird ohne Schmiermittel geliefert. Es ist jedoch mit Einfüllschraube, Überdruckventil und Ablassschraube ausgerüstet. Das benötigte mineralische Öl kann über die Einfüllschraube eingefüllt werden. Sollte synthetisches Öl bevorzugt werden, so ist sind das eingebaute Überdruckventil durch eine geschlossenen Schraube zu ersetzen.
In Tabelle 1 ist die Schmiermenge und das empfohlene Schmiermittel angegeben
In Tabelle 2 sind die zulässigen Radial - und Axialbelastungen des Getriebes aufgeführt.

F Le réducteur de type X113 est fourni sans lubrification et avec un bouchon de remplissage, de niveau et d'évacuation de l'huile. L'utilisateur peut y verser de l'huile minérale en conservant les bouchons existants. S'il y versera de l'huile synthétique, il devra substituer les bouchons existants avec d'autres bouchons de type fermé.
Voir tableau 1 concernant les huiles et les quantités conseillées.
Voir tableau 2 concernant les charges radiales et axiales applicables au réducteur

E El reductor tamaño X113 se suministra sin lubricante, provisto de tapones de respiración, nivel y descarga de aceite. El usuario puede utilizar aceite mineral, manteniendo los tapones existentes. Si prefiere utilizar aceite sintético deberá sustituir los tapones existentes por tapones ciegos. La prerreducción se suministra con tapones ciegos, lubricado de por vida con aceite sintético.
Ver tabla 1, para cantidades y aceites recomendados.
En la tabla 2, se encuentran las cargas radiales y axiales admitidas por el reductor.

Standard supplied	For these mounting position specify in the order or add oil Per queste posizioni specificare in fase d'ordine o aggiungere olio					
B3	B6	B7	B8	V5	V6	V8
13.50 LT	8.00 LT	15.50 LT	14.50 LT	22.00 LT	13.00 LT	Ask
SHELL Omala S2 GX 460				ENI Blasias 460		

For all details on lubrication and plugs check our website **tab. 1**
Per maggiori dettagli su lubrificazione e tappi olio vedi il nostro sito web

RADIAL AND AXIAL LOADS

Output shaft
Albero di uscita

$F_{eq} = F_R \cdot \frac{325.5}{X+255.5}$

n_2	FA	FR	n_2	FA	FR	n_2	FA	FR
300	2100	10500	140	3100	15500	70	4200	21000
250	2600	13000	120	3240	16200	40	5600	28000
200	3000	15000	85	3600	18000	15	8000	40000

Input shaft
Albero in entrata

n_1	FA	FR
1400	1120	5600
900	1220	6100
500	1300	6500

tab. 2

PX113C... Basic Gearbox
Riduttore base

Gearbox weight **170 kg**
peso riduttore

M. flanges	Kit code	øF	A
132B5	KC110.9.052	300	449.5
160B5	KC110.9.053	350	474.5
180B5	KC110.9.053 B	350	474.5
200B5	KC110.9.054	400	474.5
225B5	KC110.9.055	450	501.5

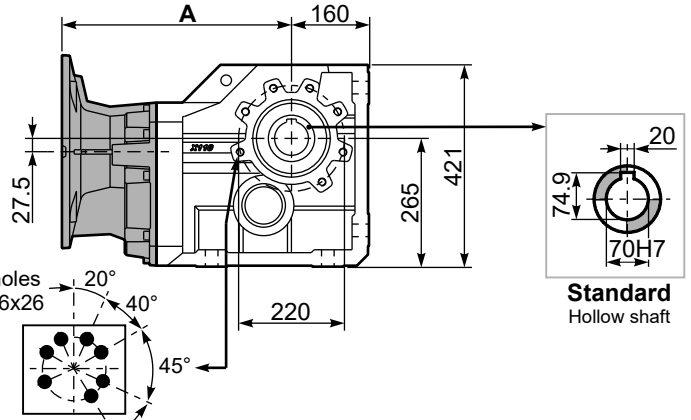
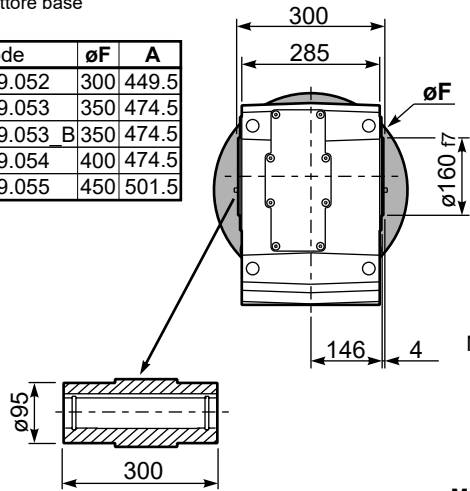
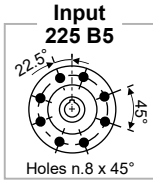

Mounting holes position
Posizione fori di montaggio

PX113...FB.. Feet
Piedini

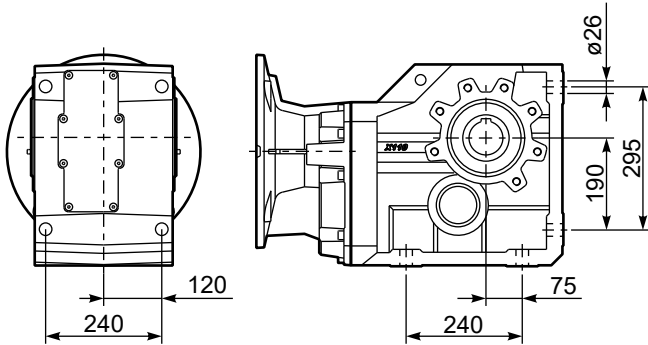

PX113...-F7.. Output flange
Flangia uscita

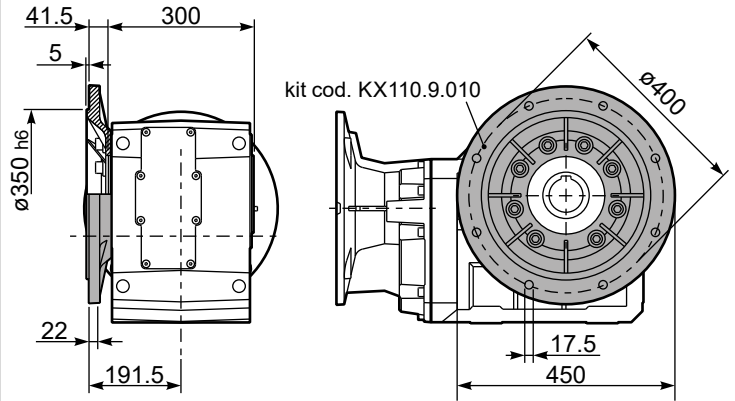

PX113...BR.. Reaction Arm
Braccio di reazione

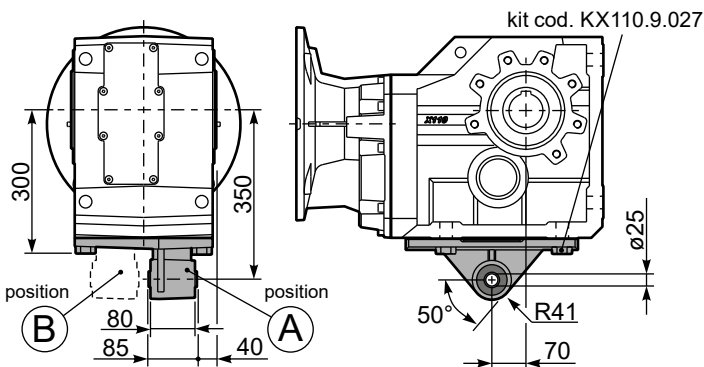

RX113... Input shaft
Albero in entrata

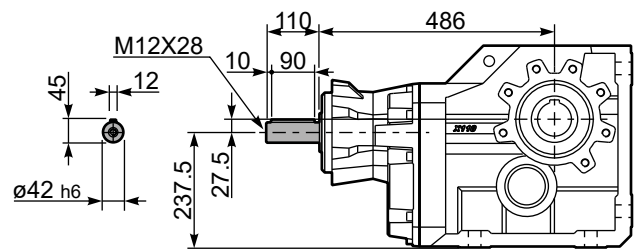

PX113A... Single shaft
Albero lento semplice

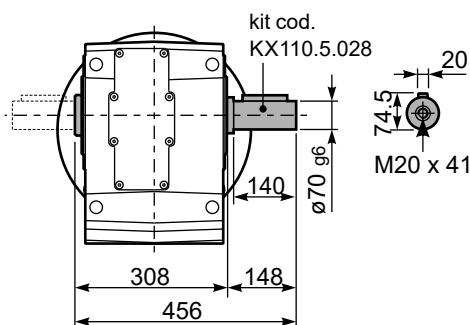

PX113B... Double shaft
Albero lento bisp.

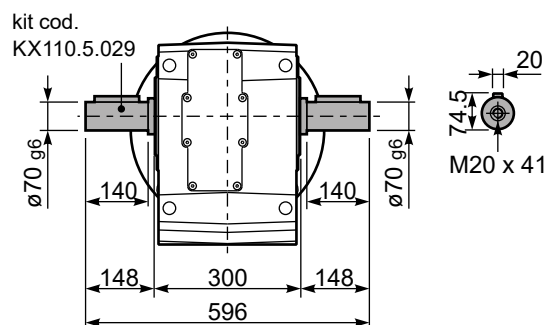

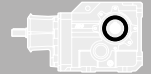

QUICK SELECTION / Selezione veloce

input speed (n_1) = 1400 min⁻¹

Output Speed n_2 [min ⁻¹]	Ratio i	Motor power P_{1M} [kW]	Output torque M_{2M} [Nm]	Service factor f.s.	Nominal power P_{1R} [kW]	Nominal torque M_{2R} [Nm]	B5 motor flanges			B14 motor flanges		Output Shaft \varnothing	Ratios code
							-F	-G	-H	-U	-V		
							100 112	132	160	100 112	132		
28.8	48.57	15	4390	1.0	14.8	4500						30142911	01
20.5	68.43	11	4545	1.0	10.7	4600						20142914	02
18.7	74.95	11	4977	0.9	9.8	4600						20142913	03
15.1	92.53	7.5	4216	1.1	7.9	4600						16142914	04
13.8	101.33	7.5	4617	1.0	7.2	4600						16142913	05
11.6	120.33	5.5	4051	1.1	6.1	4600						13142914	06
11.3	123.75	5.5	4166	1.1	5.8	4500						16142911	07
10.6	131.78	5.5	4436	1.0	5.6	4600						13142913	08
9.5	147.28	5.5	4958	0.9	5.0	4600						11142914	09
8.7	161.30	4	3972	1.2	4.5	4600						11142913	10
7.1	196.98	3	3652	1.2	3.6	4500						11142911	11
6.6	212.99	3	3949	1.2	3.4	4600						8142914	12
6.0	233.26	3	4324	1.1	3.1	4600						8142913	13
4.9	284.86	2.2	3889	1.2	2.5	4500						8142911	14

The dynamic efficiency is **0.92** for all ratios

Motor Flanges Available
Flange Motore Disponibili

B) Supplied with Reduction Bushing
Fornito con Bussola di Riduzione

B) Available on Request without reduction bushing
Disponibile a Richiesta senza Bussola di Riduzione

C) Motor Flange Holes Position
Posizione Fori Flangia Motore

EN Unit **X114** is supplied without lubricant and equipped with a breather, level and drain plugs. User can add mineral oil keeping existing plugs. Should the user wish to fill it with synthetic oil, it is recommended to replace the existing plugs with a closed plug. See table 1 for lubrication and recommended quantity. In table 2 please see possible radial loads and axial loads on the gearbox.

I Il riduttore tipo **X114** è fornito privo di lubrificazione con tappi di sfiato, livello e scarico olio. L'utente può immettere olio minerale mantenendo i tappi esistenti. Se immetterà olio sintetico, dovrà sostituire i tappi esistenti con altri tipo chiuso. Tab.1 per oli e quantità consigliati. Tab.2 carichi radiali e assiali applicabili al riduttore.

D Das Getriebe der Baugröße **X114** wird ohne Schmiermittel geliefert. Es ist jedoch mit Einfüllschraube, Überdruckventil und Ablassschraube ausgerüstet. Das benötigte mineralische Öl kann über die Einfüllschraube eingefüllt werden. Sollte synthetisches Öl bevorzugt werden, so ist sind das eingebaute Überdruckventil durch eine geschlossenen Schraube zu ersetzen. In Tabelle 1 ist die Schmiermenge und das empfohlene Schmiermittel angegeben. In Tabelle 2 sind die zulässigen Radial - und Axialbelastungen des Getriebes aufgeführt.

F Le réducteur de type **X114** est fourni sans lubrification et avec un bouchon de remplissage, de niveau et d'évacuation de l'huile. L'utilisateur peut y verser de l'huile minérale en conservant les bouchons existants. S'il y versera de l'huile synthétique, il devra substituer les bouchons existants avec d'autres bouchons de type fermé. Voir tableau 1 concernant les huiles et les quantités conseillées. Voir tableau 2 concernant les charges radiales et axiales applicables au réducteur.

E El reductor tamaño **X114** se suministra sin lubricante, provisto de tapones de respiración, nivel y descarga de aceite. El usuario puede utilizar aceite mineral, manteniendo los tapones existentes. Si prefiere utilizar aceite sintético deberá sustituir los tapones existentes por tapones ciegos. La prerreducción se suministra con tapones ciegos, lubricado de por vida con aceite sintético. Ver tabla 1, para cantidades y aceites recomendados. En la tabla 2, se encuentran las cargas radiales y axiales admitidas por el reductor.

Standard supplied	For these mounting position specify in the order or add oil					
	Per queste posizioni specificare in fase d'ordine o aggiungere olio					
B3	B6	B7	B8	V5	V6	V8
14.50 LT	8.50 LT	16.50 LT	16.00 LT	23.00 LT	14.50 LT	Ask
SHELL Omala S2 GX 460			ENI Blasias 460			

For all details on lubrication and plugs check our website **tab. 1**
Per maggiori dettagli su lubrificazione e tappi olio vedi il nostro sito web

RADIAL AND AXIAL LOADS

Output shaft
Albero di uscita

$F_{eq} = FR \cdot \frac{325.5}{X+255.5}$

n_2	FA	FR	n_2	FA	FR	n_2	FA	FR
300	2100	10500	140	3100	15500	70	4200	21000
250	2600	13000	120	3240	16200	40	5600	28000
200	3000	15000	85	3600	18000	15	8000	40000

Input shaft
Albero in entrata

n_1	FA	FR
1400	700	3500
900	840	4200
500	900	4500

tab. 2

PX114C... Basic Gearbox
Riduttore base

Gearbox weight **161 kg**
peso riduttore

M. flanges	Kit code	øF	A
100/112B5	K023.4.043	250	442
132B5	KC51.4.043C	300	463.5
160B5	KC86.4.043	350	495.5
100/112B14	K085.4.047	160	442
132B14	KC51.4.041C	200	463.5

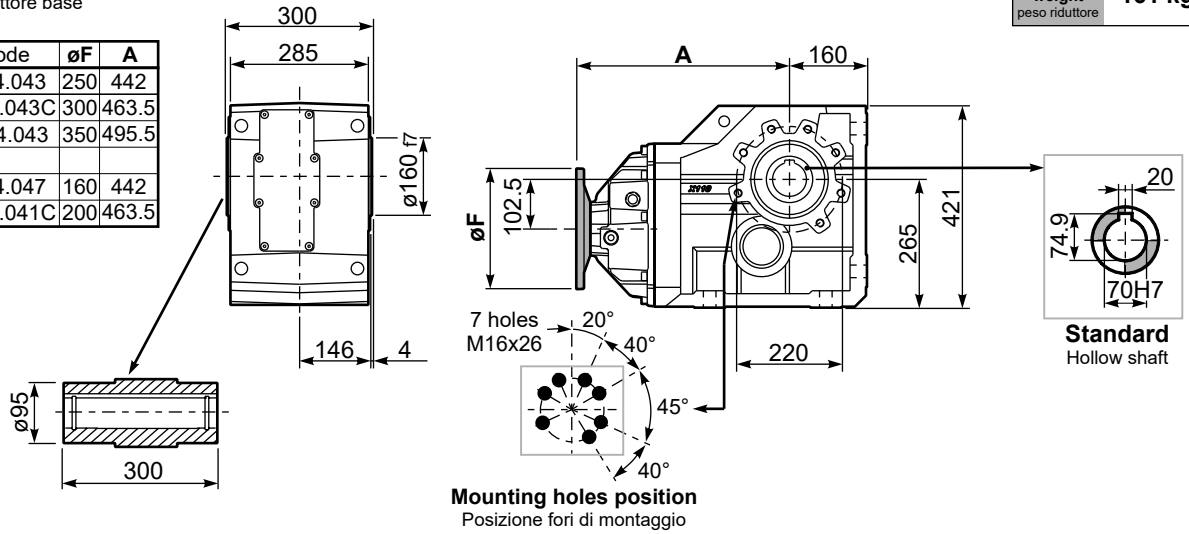

PX114...FB.. Feet
Piedini

PX114...-F7.. Output flange
Flangia uscita

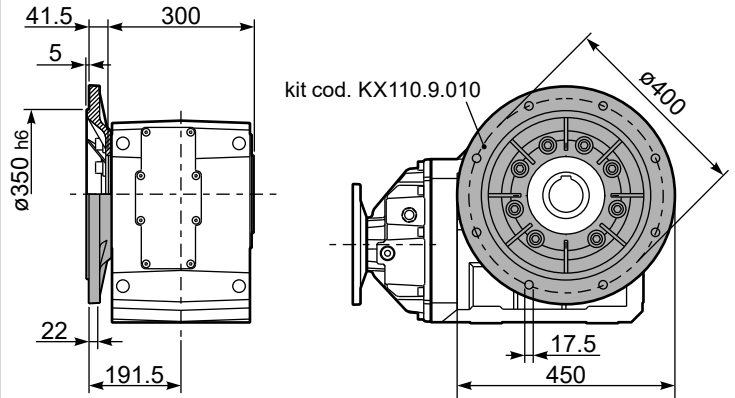
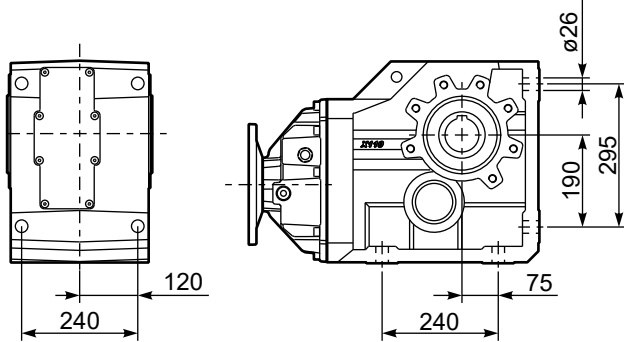

PX114...BR.. Reaction Arm
Braccio di reazione

RX114... Input shaft
Albero in entrata

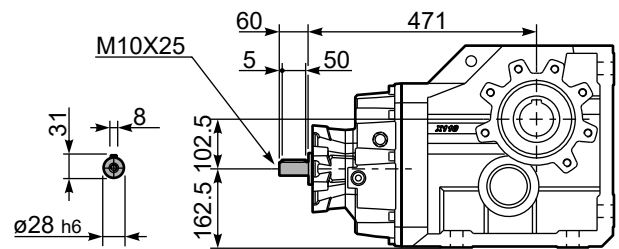
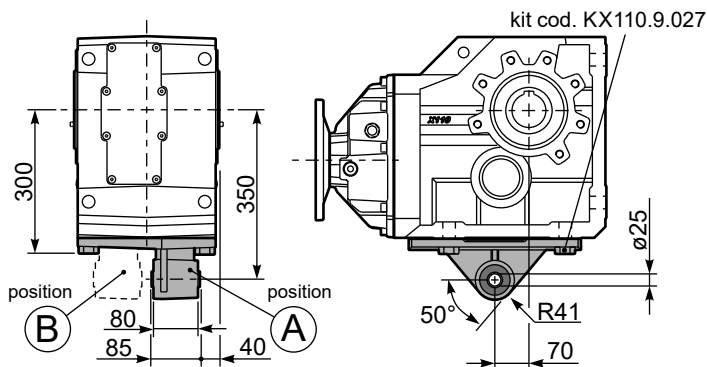

PX114A... Single shaft
Albero lento semplice

PX114B... Double shaft
Albero lento bisp.

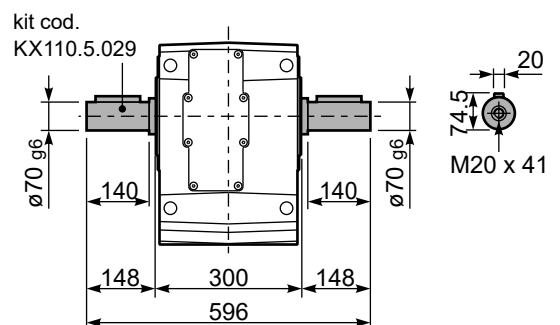
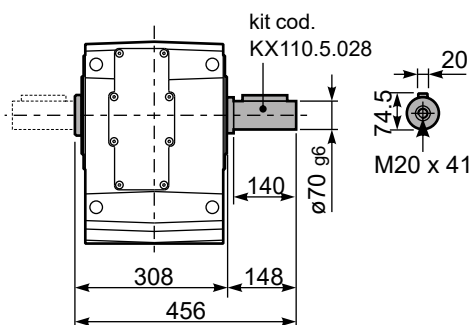

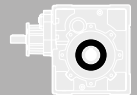

QUICK SELECTION / Selezione veloce

input speed (n_1) = 1400 min⁻¹

Output Speed n_2 [min ⁻¹]	Ratio i	Motor power P_{1M} [kW]	Output torque M_{2M} [Nm]	Service factor f.s.	Nominal power P_{1R} [kW]	Nominal torque M_{2R} [Nm]	Available B5 motor flanges					Available B14 motor flanges				Output Shaft 	Ratios code	
							-C	-D	-E	-F	-G	-R	-T	-U	-V			
							71	80	90	100 112	132	80	90	100 112	132			
176	7.94	7.5	369	1.0	7.5	380	B										302418	01
153	9.13	7.5	425	0.9	6.7	390	B										302416	02
131	10.66	5.5	366	1.1	6.0	410	B										302414	03
94	14.97	5.5	514	1.1	6.0	580	B										202418	04
81	17.21	5.5	591	1.0	5.4	600	B										202416	05
69	20.24	5.5	695	1.0	5.2	675	B										162418	06
60	23.27	4	585	1.2	4.5	675	B										162416	07
53	26.31	4	661	1.0	4.0	675	B										132418	08
46.3	30.25	4	760	0.9	3.5	675	B										132416	09
39.6	35.32	3	668	1.0	3.0	675	B										132414	10
37.8	37.03	3	701	1.0	2.8	675	B										112416	11
32.4	43.23	2.2	602	1.1	2.4	675	B										112414	12
30.1	46.58	2.2	649	1.0	2.3	675	B										82418	13
26.1	53.55	2.2	746	0.9	2.0	675	B										82416	14
22.4	62.52	1.5	600	1.1	1.7	675	B										82414	15
19.0	73.75	1.1	517	1.1	1.2	580	B										62416	16
16.3	86.09	1.1	604	1.1	1.2	675	B										62414	17

The dynamic efficiency is **0.94** for all ratios

- Motor Flanges Available
Flange Motore Disponibili
- B) Supplied with Reduction Bushing
Fornito con Bussola di Riduzione
- B) Available on Request without reduction bushing
Disponibile a Richiesta senza Bussola di Riduzione
- C) Motor Flange Holes Position
Posizione Fori Flangia Motore

EN Unit **113C** is supplied with synthetic oil for lifetime lubrication, no maintenance is necessary. See table 1 for lubrication and recommended quantity. In table 2 please see possible radial loads and axial loads on the gearbox.

I Il riduttore **113C** viene fornito completo di olio sintetico per la lubrificazione permanente e non necessita di alcuna manutenzione. Vedi tab.1 per oli e quantità consigliati. In tab.2 sono presenti i carichi radiali e assiali applicabili al riduttore.

D Das Getriebe **113C** ist mit synthetischem Öl gefüllt und ist lebensdauergeschmiert. In Tabelle 1 ist die Schmiermenge und das empfohlene Schmiermittel angegeben. In Tabelle 2 sind die zulässigen Radial - und Axialbelastungen des Getriebes aufgeführt.

F Le réducteur **113C** est fourni complet avec de l'huile synthétique pour la lubrification permanente et ne nécessite aucun entretien. Voir tableau 1 concernant les huiles et les quantités conseillées. Les charges radiales et axiales applicables au réducteur sont précisées dans le tableau 2.

E El reductor tamaño **113C** se suministra, lubricado de por vida con aceite sintético y no requieren mantenimiento alguna. Ver tabla 1, para cantidades y aceites recomendados. En la tabla 2, se encuentran las cargas radiales y axiales admitidas por el reductor.

Standard supplied	For these mounting position specify in the order or add oil Per queste posizioni specificare in fase d'ordine o aggiungere olio					
4.00 LT	2.60 LT	2.60 LT	2.60 LT	5.15 LT	2.20 LT	Ask
SHELL Omala S4 WE 320				ENI Telium VSF 320		

For all details on lubrication and plugs check our website [tab. 1](#)
Per maggiori dettagli su lubrificazione e tappi olio vedi il nostro sito web

RADIAL AND AXIAL LOADS

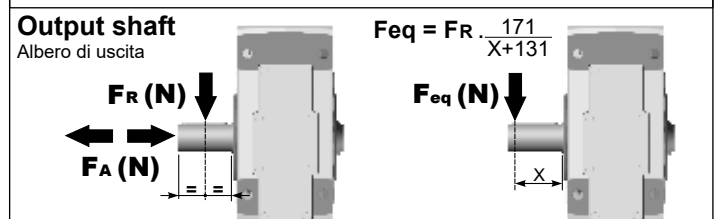

n_2	FA	FR	n_2	FA	FR	n_2	FA	FR
300	640	3200	140	860	4300	70	1080	5400
250	700	3500	120	900	4500	40	1300	6500
200	740	3700	85	1000	5000	15	1840	9200

On request reinforced bearings to increase loads.
A richiesta cuscinetti rinforzati per aumentare i carichi.

Input shaft

Albero in entrata

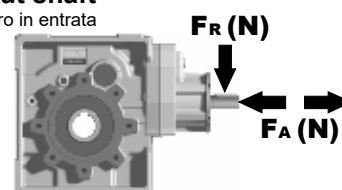

n_1	FA	FR
1400	400	2000
900	440	2200
500	440	2200

tab. 2

P113CC... Basic Gearbox
Riduttore base

Gearbox weight
peso riduttore **38.0 kg**

M. flanges	Kit code	øF	A
71B5	K023.4.041	160	240.5
80/90B5	K023.4.042	200	242.5
100/112B5	K023.4.043	250	251.5
132B5	KC51.4.043	300	272.5
80B14	K085.4.046	120	242.5
90B14	K085.4.045	140	242.5
100/112B14	K085.4.047	160	251.5
132B14	KC51.4.041	200	272.5

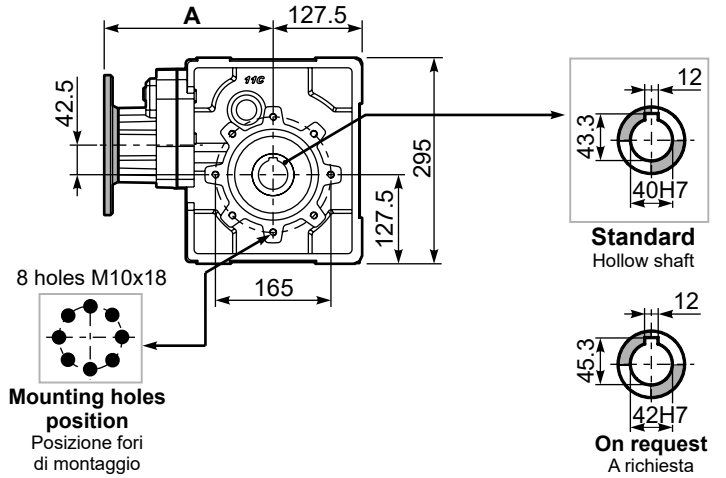
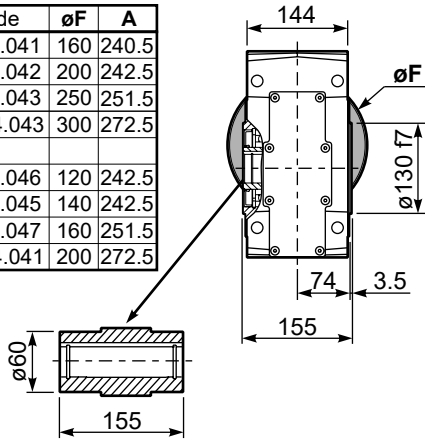

P113C...FB.. Feet
Piedini

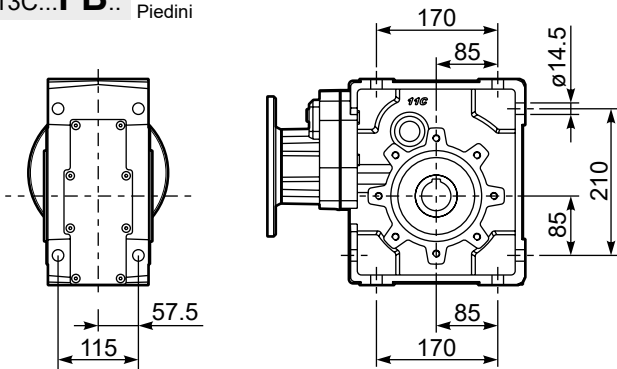

P113C...-FC.. Output flange
Flangia uscita

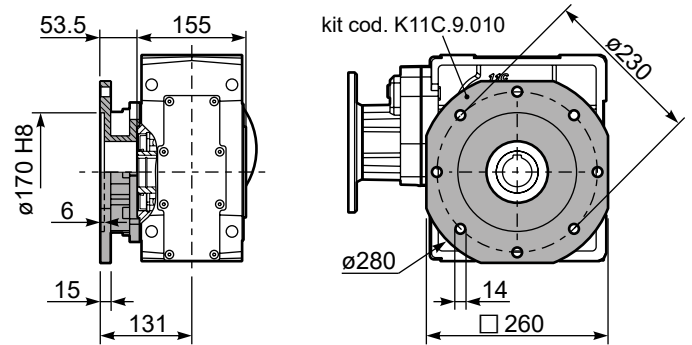

P113C...-FL.. Output flange
Flangia uscita

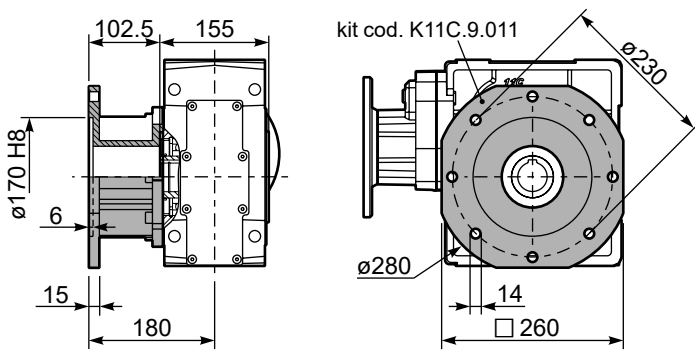

P113C...BR.. Reaction Arm
Braccio di reazione

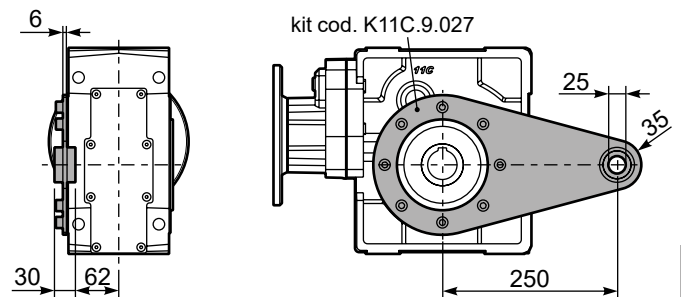

R113C... Input shaft
Albero in entrata

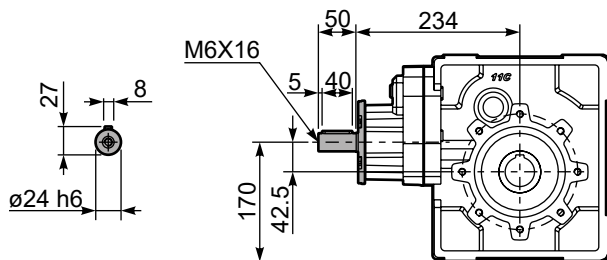

P113CA... Single shaft
Albero lento semplice

P113CB... Double shaft
Albero lento bisp.

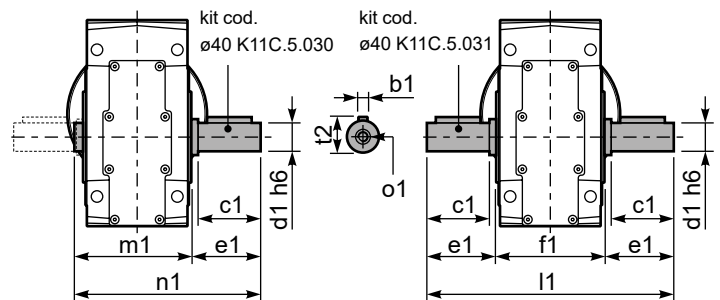

	b1	c1	d1	e1	f1	l1	m1	n1	t2	o1
ø40 Standard	12	80	40	84.5	155	324	164.5	249	43	M12
On request	-	-	-	-	-	-	-	-	-	-

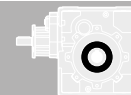

QUICK SELECTION / Selezione veloce

input speed (n_1) = 1400 min⁻¹

Output Speed n_2 [min ⁻¹]	Ratio i	Motor power P_{1M} [kW]	Output torque M_{2M} [Nm]	Service factor f.s.	Nominal power P_{1R} [kW]	Nominal torque M_{2R} [Nm]	Available B5 motor flanges				Available B14 motor flanges			Output Shaft 	Ratios code
							-B	-C	-D	-E	-Q	-R	-T		
							63	71	80	90	71	80	90		
18.7	74.79	1.5	704	1.0	1.4	675	B				C	C		19132418	01
16.3	85.99	1.1	591	1.1	1.3	675	B				C	C		19132416	02
14.0	99.66	1.1	685	1.0	1.1	675	B				C	C		17132416	03
12.0	116.35	0.75	548	1.2	0.92	675	B				C	C		17132414	04
11.5	121.45	0.75	572	1.2	0.89	675	B				C	C		13132418	05
10.0	139.64	0.75	658	1.0	0.77	675	B				C	C		13132416	06
9.2	152.21	0.75	717	0.9	0.71	675	B				C	C		19082416	07
8.6	163.02	0.55	567	1.2	0.66	675	B				C	C		13132414	08
7.9	177.69	0.55	618	1.1	0.61	675	B				C	C		19082414	09
6.8	205.95	0.55	716	0.9	0.52	675	B				C	C		17082414	10
6.3	222.52	0.55	774	0.9	0.48	675	B				C	C	On request	10132414	11
5.6	248.76	0.37	578	1.2	0.43	675	B				C	C		9132416	12
4.8	290.41	0.37	675	1.0	0.37	675	B				C	C		9132414	13
4.1	337.39	0.37	784	0.9	0.32	675	B				C	C		10082416	14
3.6	393.88	0.25	618	1.1	0.27	675	B				C	C		10082414	15
3.2	440.33	0.25	690	1.0	0.24	675	B				C	C		9082416	16
2.7	514.06	0.18	616	1.1	0.21	675	B				C	C		9082414	17
2.4	581.44	0.18	697	1.0	0.18	675	B				C	C		7082416	18
2.1	678.79	0.12	526	1.3	0.16	675	B				C	C		7082414	19

The dynamic efficiency is **0.92** for all ratios

A Motor Flanges Available
Flange Motore Disponibili

B Supplied with Reduction Bushing
Fornito con Bussola di Riduzione

B Available on Request without reduction bushing
Disponibile a Richiesta senza Bussola di Riduzione

C Motor Flange Holes Position
Posizione Fori Flangia Motore

EN Unit **114C** is supplied with synthetic oil for lifetime lubrication, no maintenance is necessary. See table 1 for lubrication and recommended quantity. In table 2 please see possible radial loads and axial loads on the gearbox.

I Il riduttore **114C** viene fornito completo di olio sintetico per la lubrificazione permanente e non necessita di alcuna manutenzione. Vedi tab.1 per oli e quantità consigliati. In tab.2 sono presenti i carichi radiali e assiali applicabili al riduttore.

D Das Getriebe **114C** ist mit synthetischem Öl gefüllt und ist lebensdauergeschmiert. In Tabelle 1 ist die Schmiermenge und das empfohlene Schmiermittel angegeben. In Tabelle 2 sind die zulässigen Radial - und Axialbelastungen des Getriebes aufgeführt.

F Le réducteur **114C** est fourni complet avec de l'huile synthétique pour la lubrification permanente et ne nécessite aucun entretien. Voir tableau 1 concernant les huiles et les quantités conseillées. Les charges radiales et axiales applicables au réducteur sont précisées dans le tableau 2.

E El reductor tamaño **114C** se suministra, lubricado de por vida con aceite sintético y no requieren mantenimiento alguna. Ver tabla 1, para cantidades y aceites recomendados. En la tabla 2, se encuentran las cargas radiales y axiales admitidas por el reductor.

Standard supplied	For these mounting position specify in the order or add oil Per queste posizioni specificare in fase d'ordine o aggiungere olio					
4.10 LT	2.70 LT	2.70 LT	2.70 LT	5.30 LT	2.35 LT	Ask
SHELL Omala S4 WE 320				ENI Telium VSF 320		

For all details on lubrication and plugs check our website [Per maggiori dettagli su lubrificazione e tappi olio vedi il nostro sito web](#) **tab. 1**

RADIAL AND AXIAL LOADS

Output shaft
Albero di uscita

$F_{eq} = FR \frac{171}{X+131}$

n_2	FA	FR	n_2	FA	FR	n_2	FA	FR
300	640	3200	140	860	4300	70	1080	5400
250	700	3500	120	900	4500	40	1300	6500
200	740	3700	85	1000	5000	15	1840	9200

On request reinforced bearings to increase loads.
A richiesta cuscinetti rinforzati per aumentare i carichi.

Input shaft
Albero in entrata

n_1	FA	FR
1400	240	1200
900	280	1400
500	310	1700

tab. 2

P114CC... Basic Gearbox
Riduttore base

Gearbox weight
peso riduttore **38.0 kg**

M. flanges	Kit code	øF	A
63B5	K063.4.041	140	252.5
71B5	K063.4.042	160	250.5
80/90B5	K063.4.043	200	252.5
71B14	K063.4.047	105	250.5
80B14	K063.4.046	120	252.5
90B14	K063.4.041	140	252.5

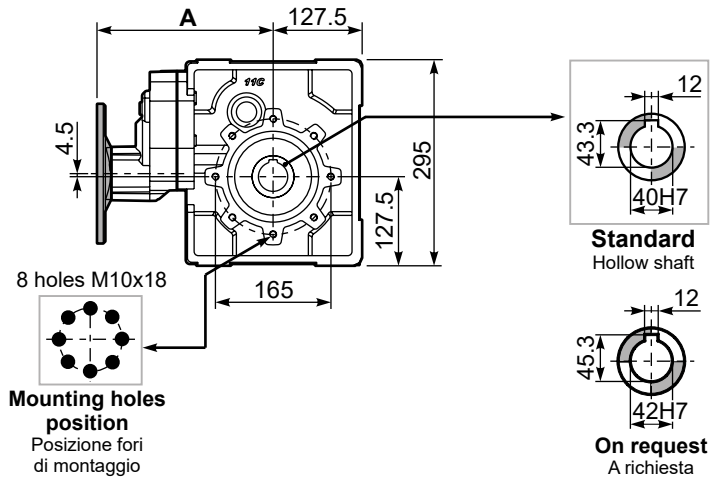
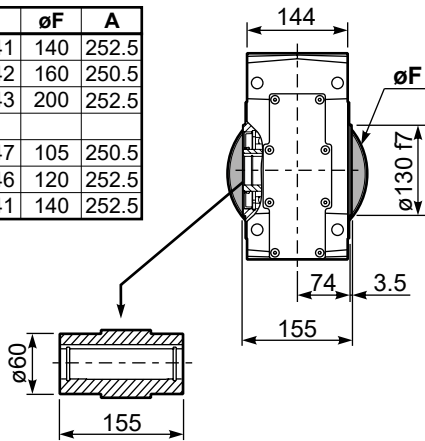

P114C...FB.. Feet
Piedini

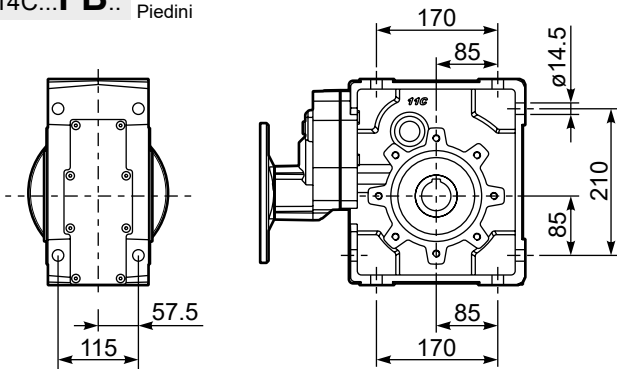

P114C...-FC.. Output flange
Flangia uscita

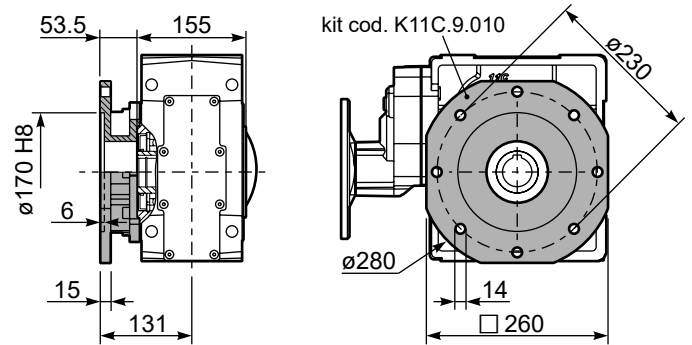

P114C...-FL.. Output flange
Flangia uscita

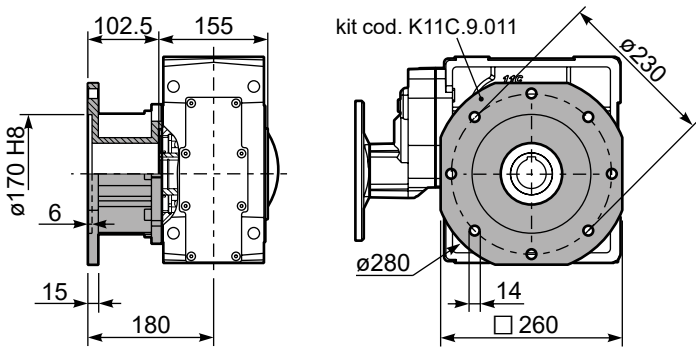

P114C...BR.. Reaction Arm
Braccio di reazione

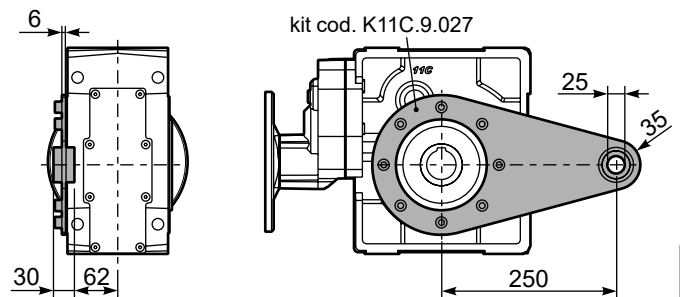

R114C... Input shaft
Albero in entrata

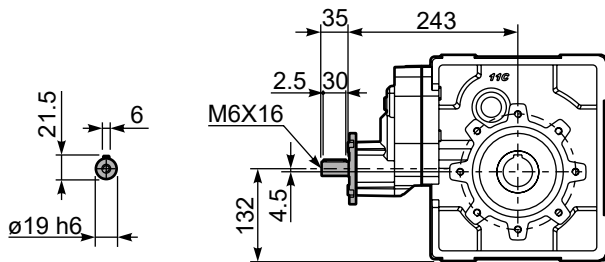

P114CA... Single shaft
Albero lento semplice

P114CB... Double shaft
Albero lento bisp.

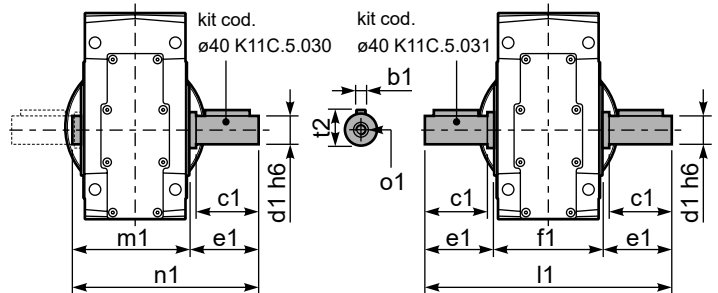

	b1	c1	d1	e1	f1	l1	m1	n1	t2	o1
ø40 Standard	12	80	40	84.5	155	324	164.5	249	43	M12
On request	-	-	-	-	-	-	-	-	-	-

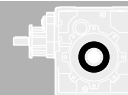

QUICK SELECTION / Selezione veloce

input speed (n_1) = 1400 min⁻¹

Output Speed n_2 [min ⁻¹]	Ratio i	Motor power P_{1M} [kW]	Output torque M_{2M} [Nm]	Service factor $f.s.$	Nominal power P_{1R} [kW]	Nominal torque M_{2R} [Nm]	Available B5 motor flanges					Available B14 motor flanges				Output Shaft \varnothing	Ratios code
							-C	-D	-E	-F	-G	-R	-T	-U	-V		
							71	80	90	100 112	132	80	90	100 112	132		
145	9.69	9	560	1.3	12.2	755	B									302418	01
126	11.09	9	641	1.1	9.6	680	B									302416	02
108	12.90	9	746	1.1	9.6	790	B									302414	03
77	18.26	7.5	849	1.1	8.0	935	B									202418	04
67	20.91	7.5	972	1.0	7.5	1000	B									202416	05
58	24.32	5.5	835	1.2	6.4	1000	B									202414	06
49.5	28.27	5.5	971	1.0	5.5	1000	B									162416	07
42.6	32.88	4	826	1.2	4.7	1000	B									162414	08
38.1	36.76	4	924	1.1	4.2	1000	B									132416	09
32.7	42.76	3	809	1.2	3.6	1000	B									132414	10
31.1	45.00	3	851	1.2	3.5	1000	B									112416	11
26.8	52.33	3	990	1.0	3.0	1000	B									112414	12
24.6	56.82	2.2	791	1.1	2.3	850	B									82418	13
21.5	65.07	2.2	906	1.1	2.3	975	B									82416	14
18.5	75.68	2.2	1054	0.9	2.1	1000	B									82414	15
15.6	89.61	1.1	628	1.1	1.2	710	B									62416	16
13.4	104.22	1.1	731	1.1	1.2	820	B									62414	17

The dynamic efficiency is **0.94** for all ratios

- Motor Flanges Available** Flange Motore Disponibili
- B) Supplied with Reduction Bushing** Fornito con Bussola di Riduzione
- B) Available on Request without reduction bushing** Disponibile a Richiesta senza Bussola di Riduzione
- C) Motor Flange Holes Position** Posizione Fori Flangia Motore

EN Unit 133C is supplied without lubricant and equipped with a breather, level and drain plugs. User can add mineral oil keeping existing plugs. Should the user wish to fill it with synthetic oil, it is recommended to replace the existing plugs with a closed plug. See table 1 for lubrication and recommended quantity. In table 2 please see possible radial loads and axial loads on the gearbox.

I Il riduttore tipo 133C è fornito privo di lubrificazione con tappi di sfiato, livello e scarico olio. L'utente può immettere olio minerale mantenendo i tappi esistenti. Se immetterà olio sintetico, dovrà sostituire i tappi esistenti con altri tipo chiuso. Tab.1 per oli e quantità consigliati. Tab.2 carichi radiali e assiali applicabili al riduttore.

D Das Getriebe der Baugröße 133C wird ohne Schmiermittel geliefert. Es ist jedoch mit Einfüllschraube, Überdruckventil und Ablassschraube ausgerüstet. Das benötigte mineralische Öl kann über die Einfüllschraube eingefüllt werden. Sollte synthetisches Öl bevorzugt werden, so ist sind das eingebaute Überdruckventil durch eine geschlossenen Schraube zu ersetzen. In Tabelle 1 ist die Schmiermenge und das empfohlene Schmiermittel angegeben. In Tabelle 2 sind die zulässigen Radial - und Axialbelastungen des Getriebes aufgeführt.

F Le réducteur de type 133C est fourni sans lubrification et avec un bouchon de remplissage, de niveau et d'évacuation de l'huile. L'utilisateur peut y verser de l'huile minérale en conservant les bouchons existants. S'il y versera de l'huile synthétique, il devra substituer les bouchons existants avec d'autres bouchons de type fermé. Voir tableau 1 concernant les huiles et les quantités conseillées. Voir tableau 2 concernant les charges radiales et axiales applicables au réducteur.

E El reductor tamaño 133C se suministra sin lubricante, provisto de tapones de respiración, nivel y descarga de aceite. El usuario puede utilizar aceite mineral, manteniendo los tapones existentes. Si prefiere utilizar aceite sintético deberá sustituir los tapones existentes por tapones ciegos. La prerreducción se suministra con tapones ciegos, lubricado de por vida con aceite sintético. Ver tabla 1, para cantidades y aceites recomendados. En la tabla 2, se encuentran las cargas radiales y axiales admitidas por el reductor.

6.00 LT	4.30 LT	4.30 LT	3.30 LT	7.20 LT	3.10 LT	Ask
SHELL Omala S2 GX 460				ENI Blasias 460		

For all details on lubrication and plugs check our website [tab. 1](#)
Per maggiori dettagli su lubrificazione e tappi olio vedi il nostro sito web

RADIAL AND AXIAL LOADS

Output shaft
Albero di uscita

$F_{eq} = F_R \cdot \frac{184.5}{X+144.5}$

n_2	FA	FR	n_2	FA	FR	n_2	FA	FR
300	800	4000	140	1120	5600	70	1400	7000
250	900	4500	120	1200	6000	40	1700	8500
200	960	4800	85	1300	6500	15	2400	12000

On request reinforced bearings to increase loads.
A richiesta cuscinetti rinforzati per aumentare i carichi.

Input shaft
Albero in entrata

n_1	FA	FR
1400	450	2250
900	500	2500
500	600	3000

tab. 2

P133CC... Basic gearbox
Riduttore base

Gearbox weight
peso riduttore **53.5 kg**

M. flanges	Kit code	øF	A
71B5	K023.4.041	160	251
80/90B5	K023.4.042	200	253
100/112B5	K023.4.043	250	262
132B5	KC51.4.043	300	283
80B14	K085.4.046	120	253
90B14	K085.4.045	140	253
100/112B14	K085.4.047	160	262
132B14	KC51.4.041	200	283

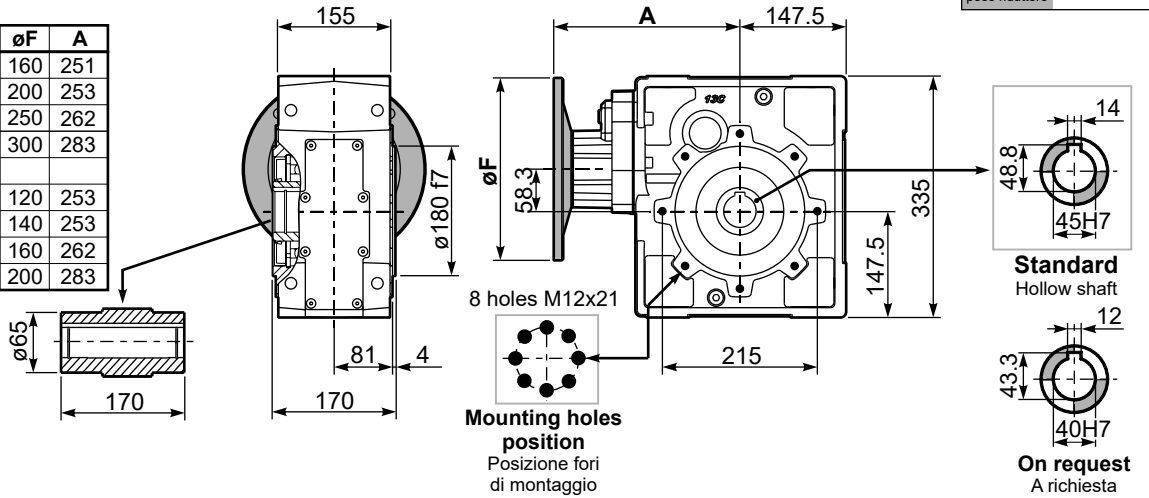

P133C...FB.. Feet
Piedini

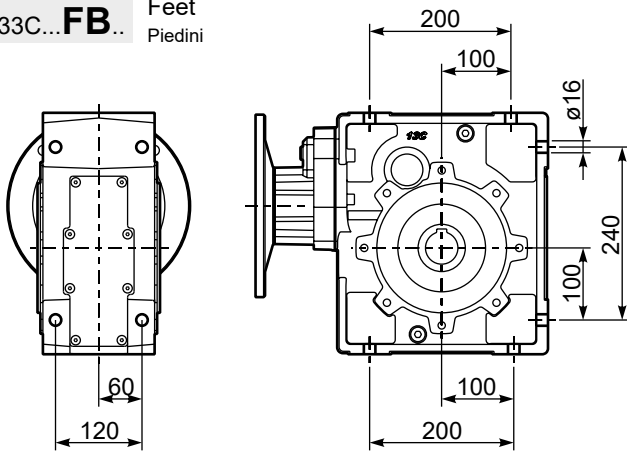

P133C...-FC.. Output flange
Flangia uscita

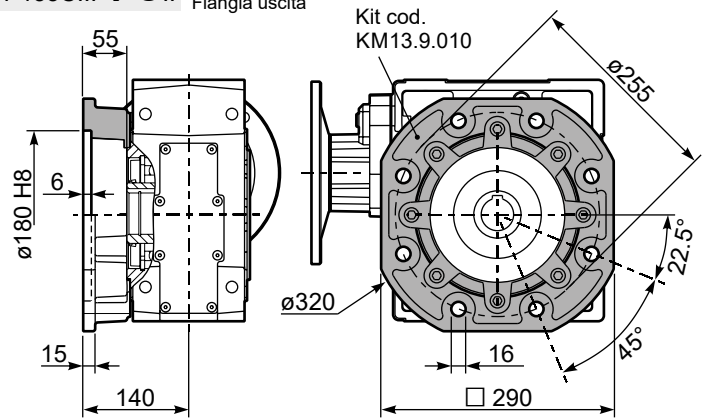

R133C... Input Shaft
Albero in entrata

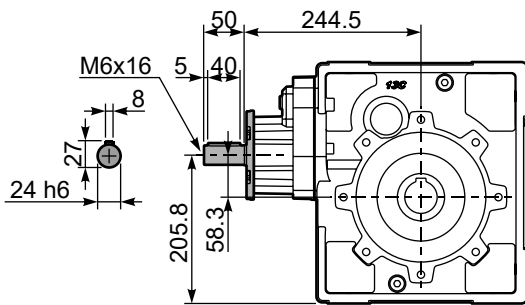

P133C...BR.. Reaction arm
Braccio di reazione

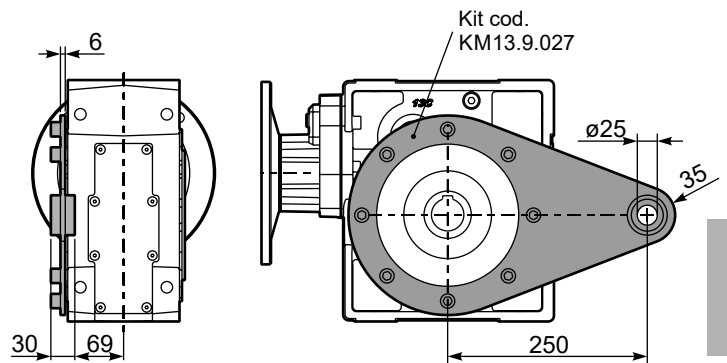

P133CA.. Single output Shaft
Albero lento semplice

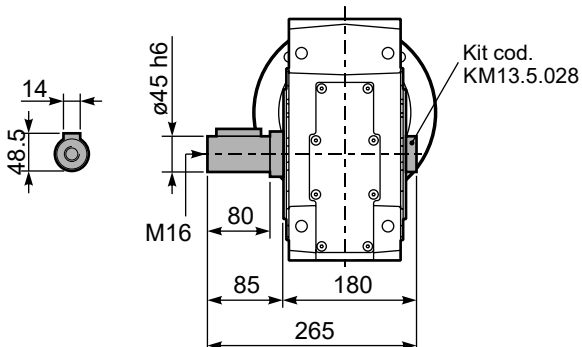

P133CB.. Double Input Shaft
Albero lento bisorgente

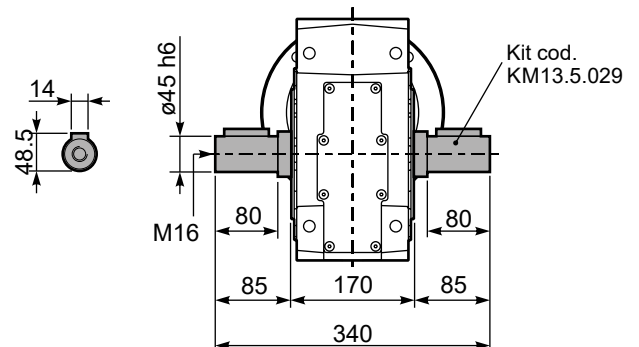

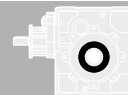

QUICK SELECTION / Selezione veloce

input speed (n_1) = 1400 min⁻¹

Output Speed n_2 [min ⁻¹]	Ratio i	Motor power P_{1M} [kW]	Output torque M_{2M} [Nm]	Service factor f.s.	Nominal power P_{1R} [kW]	Nominal torque M_{2R} [Nm]	Available B5 motor flanges				Available B14 motor flanges			Output Shaft 	Ratios code
							-B	-C	-D	-E	-Q	-R	-T		
							63	71	80	90	71	80	90		
15.3	91.23	1.5	858	1.2	1.7	1000	B				C	C		19132418	01
13.4	104.48	1.5	983	1.0	1.5	1000	B				C	C		19132416	02
11.6	121.10	1.5	1139	0.9	1.3	1000	B				C	C		17132416	03
9.9	140.84	1.1	968	1.0	1.1	1000	B				C	C		17132414	04
8.5	165.32	1.1	1136	0.9	0.96	1000	B				C	C		15132414	05
7.6	184.94	0.75	872	1.1	0.86	1000	B				C	C		19082416	06
7.1	197.34	0.75	930	1.1	0.81	1000	B				C	C		13132414	07
6.5	215.10	0.75	1014	1.0	0.74	1000	B				C	C		19082414	08
6.0	231.60	0.55	805	1.2	0.69	1000	B				C	C		10132416	09
5.6	249.31	0.55	867	1.2	0.64	1000	B				C	C		17082414	10
5.2	269.37	0.55	937	1.1	0.59	1000	B				C	C		10132414	11
4.8	292.64	0.55	1018	1.0	0.54	1000	B				C	C		15082414	12
4.6	302.26	0.55	1051	1.0	0.53	1000	B				C	C		9132416	13
4.0	349.30	0.37	812	1.2	0.46	1000	B				C	C		13082414	14
3.5	399.12	0.37	928	1.1	0.40	1000	B				C	C		7132416	15
2.9	476.80	0.37	1108	0.9	0.33	1000	B				C	C		10082414	16
2.2	622.28	0.25	976	1.0	0.26	1000	B				C	C		9082414	17
1.7	821.70	0.18	985	1.0	0.19	1000	B				C	C		7082414	18

The dynamic efficiency is **0.92** for all ratios

Motor Flanges Available Flange Motore Disponibili **B) Supplied with Reduction Bushing** Fornito con Bussola di Riduzione **B) Available on Request without reduction bushing** Disponibile a Richiesta senza Bussola di Riduzione **C) Motor Flange Holes Position** Posizione Fori Flangia Motore

EN Unit **134C** is supplied without lubricant and equipped with a breather, level and drain plugs. User can add mineral oil keeping existing plugs. Should the user wish to fill it with synthetic oil, it is recommended to replace the existing plugs with a closed plug. See table 1 for lubrication and recommended quantity. In table 2 please see possible radial loads and axial loads on the gearbox.

B3	B6	B7	B8	V5	V6	V8
6.10 LT	4.40 LT	4.40 LT	3.40 LT	7.50 LT	3.20 LT	Ask
SHELL Omala S2 GX 460				ENI Blasias 460		

For all details on lubrication and plugs check our website [Per maggiori dettagli su lubrificazione e tappi olio vedi il nostro sito web](#) **tab. 1**

I Il riduttore tipo **134C** è fornito privo di lubrificazione con tappi di sfiato, livello e scarico olio. L'utente può immettere olio minerale mantenendo i tappi esistenti. Se immetterà olio sintetico, dovrà sostituire i tappi esistenti con altri tipo chiuso. Tab.1 per oli e quantità consigliati. Tab.2 carichi radiali e assiali applicabili al riduttore.

D Das Getriebe der Baugröße **134C** wird ohne Schmiermittel geliefert. Es ist jedoch mit Einfüllschraube, Überdruckventil und Ablassschraube ausgerüstet. Das benötigte mineralische Öl kann über die Einfüllschraube eingefüllt werden. Sollte synthetisches Öl bevorzugt werden, so ist sind das eingebaute Überdruckventil durch eine geschlossenen Schraube zu ersetzen. In Tabelle 1 ist die Schmiermenge und das empfohlene Schmiermittel angegeben. In Tabelle 2 sind die zulässigen Radial - und Axialbelastungen des Getriebes aufgeführt.

F Le réducteur de type **134C** est fourni sans lubrification et avec un bouchon de remplissage, de niveau et d'évacuation de l'huile. L'utilisateur peut y verser de l'huile minérale en conservant les bouchons existants. S'il y versera de l'huile synthétique, il devra substituer les bouchons existants avec d'autres bouchons de type fermé. Voir tableau 1 concernant les huiles et les quantités conseillées. Voir tableau 2 concernant les charges radiales et axiales applicables au réducteur

E El reductor tamaño **134C** se suministra sin lubricante, provisto de tapones de respiración, nivel y descarga de aceite. El usuario puede utilizar aceite mineral, manteniendo los tapones existentes. Si prefiere utilizar aceite sintético deberá sustituir los tapones existentes por tapones ciegos. La prerreducción se suministra con tapones ciegos, lubricado de por vida con aceite sintético. Ver tabla 1, para cantidades y aceites recomendados. En la tabla 2, se encuentran las cargas radiales y axiales admitidas por el reductor.

RADIAL AND AXIAL LOADS

Output shaft Albero di uscita

$F_{eq} = FR \cdot \frac{184.5}{X+144.5}$

n_2	FA	FR	n_2	FA	FR	n_2	FA	FR
300	800	4000	140	1120	5600	70	1400	7000
250	900	4500	120	1200	6000	40	1700	8500
200	960	4800	85	1300	6500	15	2400	12000

On request reinforced bearings to increase loads.
A richiesta cuscinetti rinforzati per aumentare i carichi.

Input shaft Albero in entrata

n_1	FA	FR
1400	400	2000
900	440	2200
500	440	2200

tab. 2

P134CC... Basic gearbox
Riduttore base

Gearbox weight
peso riduttore **53.5 kg**

M. flanges	Kit code	øF	A
63B5	K063.4.041	140	263
71B5	K063.4.042	160	261
80/90B5	K063.4.043	200	263
71B14	K063.4.047	105	261
80B14	K063.4.046	120	263
90B14	K063.4.041	140	263

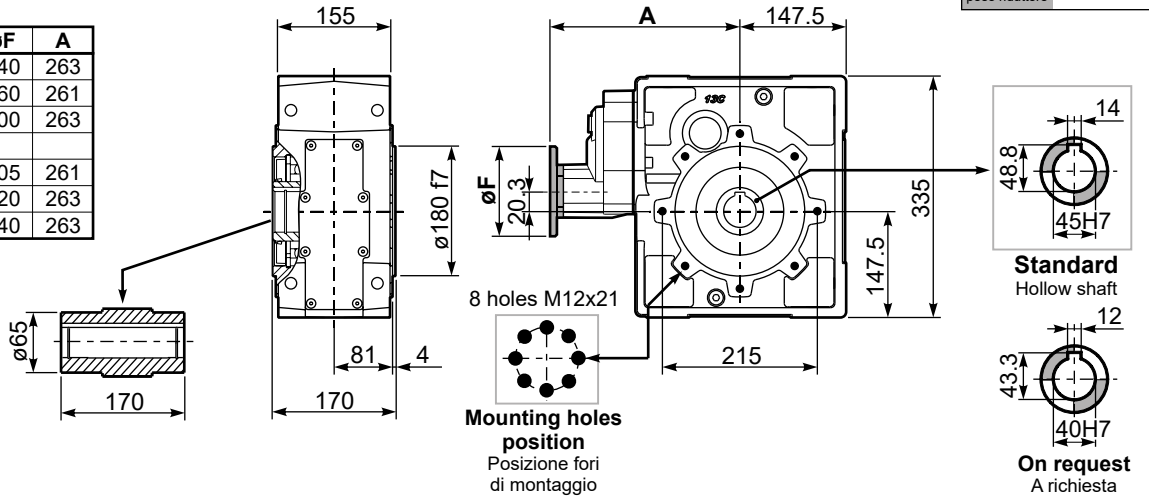

P134C...FB... Feet
Piedini

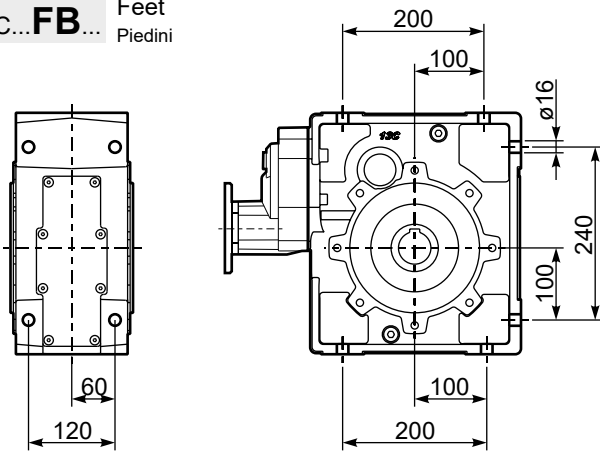

P134C...-FC.. Output flange
Flangia uscita

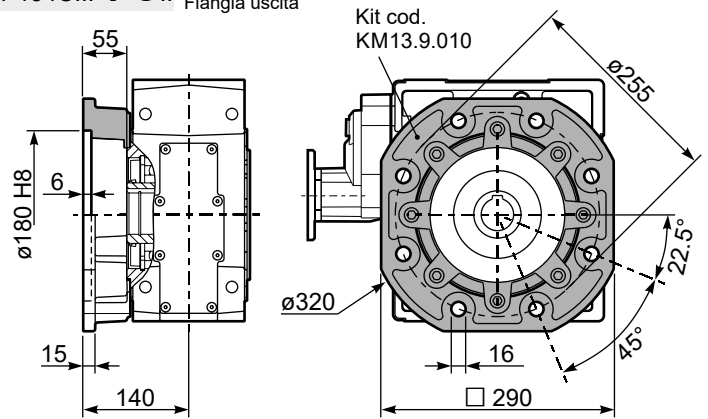

R134C... Input Shaft
Albero in entrata

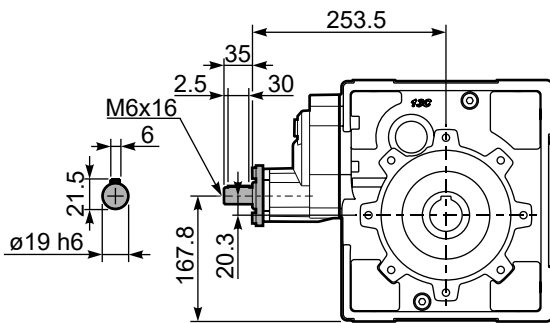

P134C...BR.. Reaction arm
Braccio di reazione

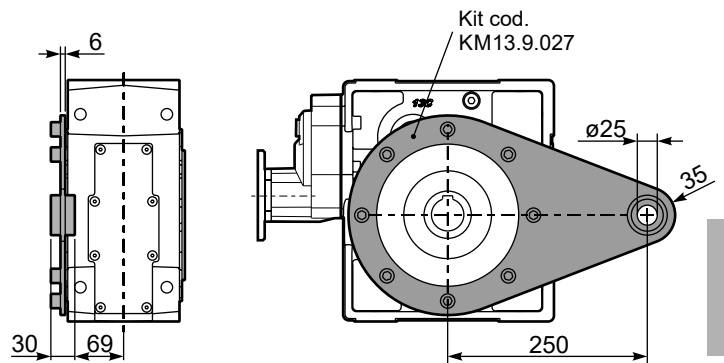

P134CA.. Single output Shaft
Albero lento semplice

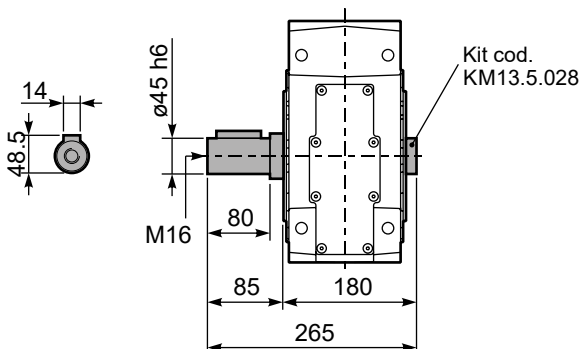

P134CB.. Double Input Shaft
Albero lento bisporgente

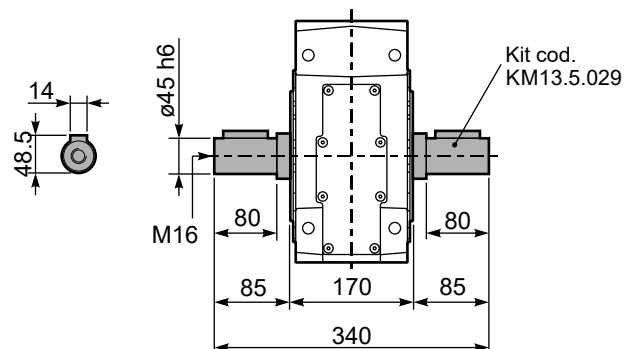

BRUSHLESS-TECH

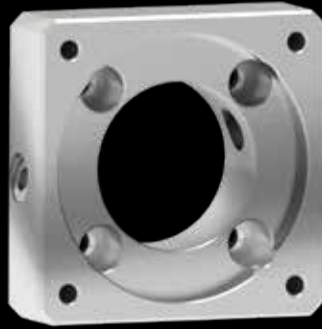

Flange for servomotor
Flange per servomotore



Coupling
Giunto



Reduction bushing
Bussola di riduzione



HYDRO · MEC

HIGH EFFICIENCY GEARBOXES

UNIQUE FEATURES

Special input shaft design with internal seal for Brushless applications.

Design speciale dell'albero di entrata con guarnizione interna per applicazioni Brushless.

1 Quality oil seals.
Anelli di tenuta di qualità.

2 All grounded gears.
Tutti gli ingranaggi rettificati.

On request FKM oil seals.
A richiesta anelli di tenuta FKM.

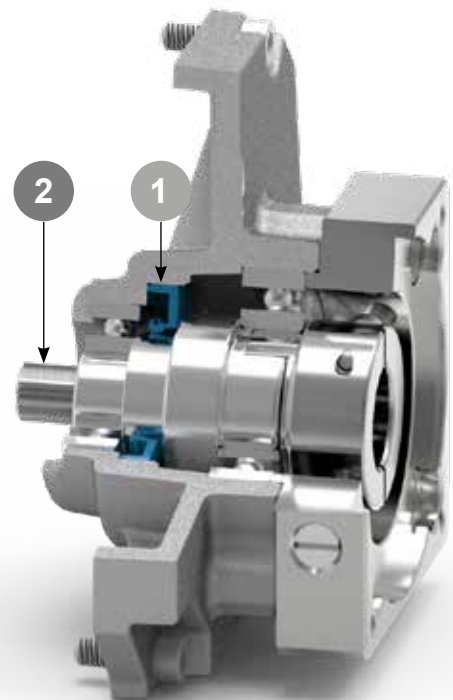

All couplings on stock.
Giunti disponibili a magazzino.



Flanges available for quantity.
Drawings available to download on the web site for a quick production of small quantity.
Flange disponibili per quantità.
Disegni scaricabili dal sito web per una rapida produzione di piccole quantità.

WORM GEARBOXES

Flanges for servomotors - Flange per servomotori

Rightangle-Gear

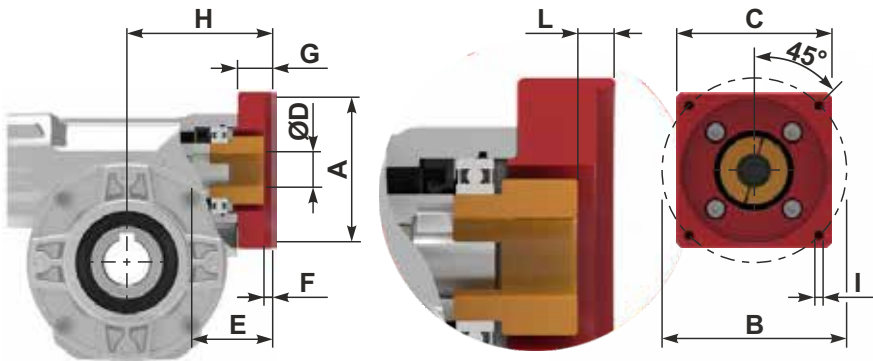

Type	Catalog Flange Code	Input Flanges Kit Code	Bushing Kit Code	Coupling Kit Code	Motor shaft Ø										
						A	B	C	ØD	E	F	G	L	I	H
030 21Nm	BA	K0304071	KBR09/14G	K0305190L	Ø9	40	63	58	Ø14	30	4	20	4.7	M5x12	68
	BC	K0304072	KBR11/14G	K0305190L	Ø11	60	75	70	Ø14	30	4.5	20	4.7	M5x12	68
	BB	K0304073	-	K0305190L	Ø14	50	70	60	Ø14	32	4.5	28.5	13.2	M5x12	76.5
045 41Nm	BC	K0504072	KBR11/14G	KC355190L	Ø11	60	75	70	Ø14	44	4.5	23	9	M5x12	79
	BB	K0504073	-	KC355190L	Ø14	50	70	70	Ø14	44	4.5	23	9	M5x12	79
	BE	K0504074	-	KC355190L	Ø14	80	100	85	Ø14	44	4.5	23	9	M6x12	79
	BB	K0504075	-	KC355190L	Ø14	95	115	100	Ø14	44	4.5	23	9	M8x12	79
	BE	K0504078	-	KC355190L	Ø14	70	90	80	Ø14	44	4.5	23	9	M6x12	79
050 72Nm	BC	K0504072	KBR11/19G	K0505190L	Ø11	60	75	70	Ø19	48	4.5	23	9	M5x12	83.5
	BC	K0504072	KBR14/19G	K0505190L	Ø14	60	75	70	Ø19	48	4.5	23	9	M5x12	83.5
	BB	K0504073	KBR14/19G	K0505190L	Ø14	50	70	70	Ø19	48	4.5	23	9	M5x12	83.5
	BE	K0504074	KBR14/19G	K0505190L	Ø14	80	100	85	Ø19	48	4.5	23	9	M6x12	83.5
	BF	K0504075	-	K0505190L	Ø19	95	115	100	Ø19	48	4.5	23	9	M8x12	83.5
	BD	K0504078	-	K0505190L	Ø19	70	90	80	Ø19	48	4.5	23	9	M6x12	83.5
063 147Nm	BC	K0634072	KBR14/22G	KC405190L	Ø14	60	75	90	Ø22	58	4.5	25	9	M5x12	104.5
	BB	K0634073	KBR14/22G	KC405190L	Ø14	50	70	80	Ø22	58	4.5	25	9	M5x12	104.5
	BE	K0634074	KBR14/22G	KC405190L	Ø14	80	100	85	Ø22	58	4.5	25	9	M6x12	104.5
63A 191Nm	BF	K0634075	KBR19/22G	KC405190L	Ø19	95	115	100	Ø22	58	4.5	25	9	M8x12	104.5
	BG	K0634076	-	KC405190L	Ø22	110	145	130	Ø22	63	4.5	30	14	M8x14	109.5
	BD	K0634078	KBR19/22G	KC405190L	Ø19	70	90	90	Ø22	58	4.5	25	9	M6x12	104.5
085 347Nm	BF	K0854075	KBR19/24G	KC505190L	Ø19	95	115	100	Ø24	60	4.5	26	9.5	M8x14	124.5
	BG	K0854076	KBR22/24G	KC505190L	Ø22	110	145	130	Ø24	64	5	30	13.5	M8x14	128.5
	BH	K0854077	-	KC505190L	Ø24	130	165	140	Ø24	60	5	26	9.5	M8x14	124.5
	BD	K0854078	KBR19/24G	KC505190L	Ø19	70	90	95	Ø24	60	4.5	26	9.5	M6x14	124.5



Supplied with reduction bushing
Fornito con bussola di riduzione

Coupling / Giunto

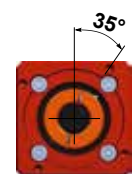

K0504072
Fixing holes shifted by 35°
Fori fissaggio motore ruotati a 35°

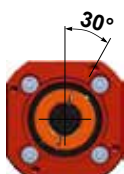

K0504073
K0634078
Fixing holes shifted by 30°
Fori fissaggio motore ruotati a 30°

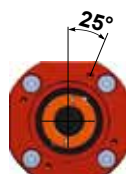

K0634072
K0634073
Fixing holes shifted by 25°
Fori fissaggio motore ruotati a 25°



Coupling tightening
Serraggio del giunto

WORM GEARBOXES

Flanges for servomotors - Flange per servomotori

Q-Square-Gear

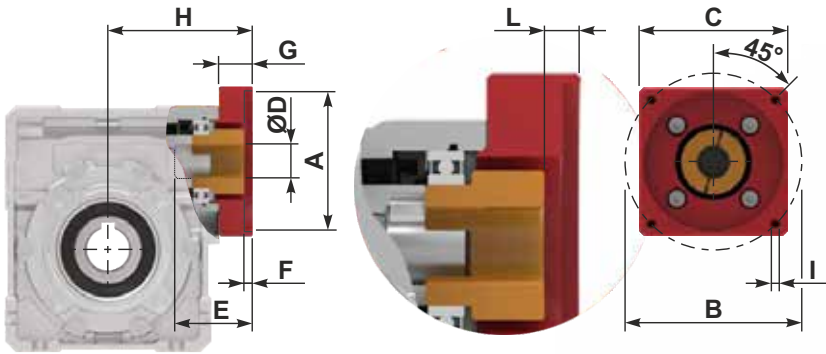

Type	Catalog Flange Code	Input Flanges Kit Code	Input Flanges Kit Code	Bushing Kit Code	Coupling Kit Code	Motor shaft Ø	A	B	C	ØD	E	F	G	L	I	H
Q63 147Nm	BC	K0634072	K0634072	KBR14/22G	KC405190L	Ø14	60	75	90	Ø22	58	4.5	25	9	M5x12	104.5
	BB	K0634073	K0634073	KBR14/22G	KC405190L	Ø14	50	70	80	Ø22	58	4.5	25	9	M5x12	104.5
	BE	K0634074	K0634074	KBR14/22G	KC405190L	Ø14	80	100	85	Ø22	58	4.5	25	9	M6x12	104.5
	BF	K0634075	K0634075	KBR19/22G	KC405190L	Ø19	95	115	100	Ø22	58	4.5	25	9	M8x12	104.5
	BG	K0634076	K0634076	-	KC405190L	Ø22	110	145	130	Ø22	63	4.5	30	14	M8x14	109.5
Q75 270Nm	BD	K0634078	K0634078	KBR19/22G	KC405190L	Ø19	70	90	90	Ø22	58	4.5	25	9	M6x12	104.5
	BF	K0854075	K0854075	KBR19/24G	KC505190L	Ø19	95	115	100	Ø24	60	4.5	26	9.5	M8x14	122
	BG	K0854076	K0854076	KBR22/24G	KC505190L	Ø22	110	145	130	Ø24	64	5	30	13.5	M8x14	126
	BH	K0854077	K0854077	-	KC505190L	Ø24	130	165	140	Ø24	60	5	26	9.5	M8x14	122
Q85 347Nm	BD	K0854078	K0854078	KBR19/24G	KC505190L	Ø19	70	90	95	Ø24	60	4.5	26	9.5	M6x14	122
	BF	K0854075	K0854075	KBR19/24G	KC505190L	Ø19	95	115	100	Ø24	60	4.5	26	9.5	M8x14	124.5
	BG	K0854076	K0854076	KBR22/24G	KC505190L	Ø22	110	145	130	Ø24	64	5	30	13.5	M8x14	128.5
	BH	K0854077	K0854077	-	KC505190L	Ø24	130	165	140	Ø24	60	5	26	9.5	M8x14	124.5

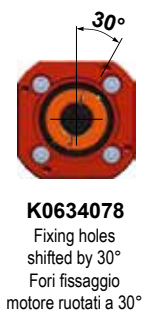

COAXIAL GEARBOXES

Flanges for servomotors - Flange per servomotori

Aluminum Coaxial-Gear

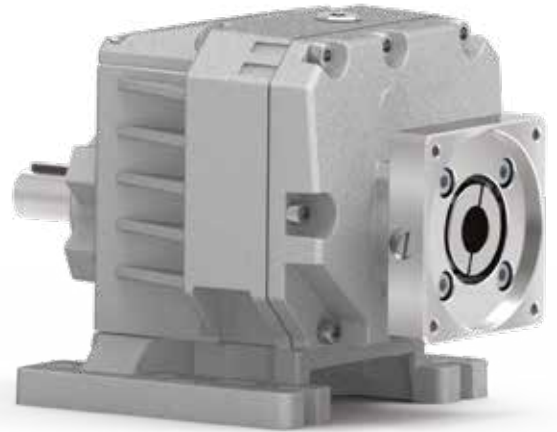
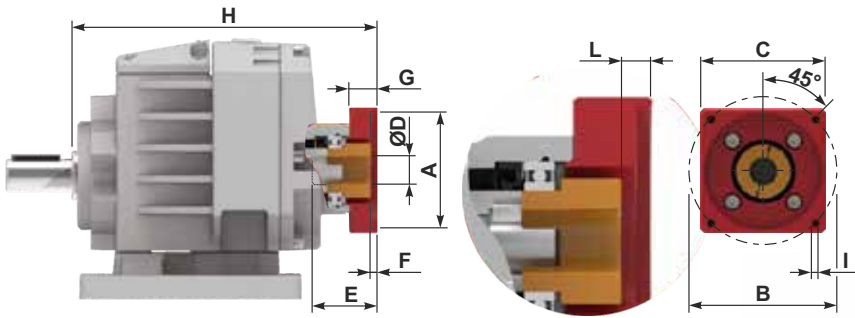

Type	Catalog Flange Code	Input Flanges Kit Code	Bushing Kit Code	Coupling Kit Code	Motor shaft Ø	A	B	C	ØD	E	F	G	L	I	H	412A	513A	613A
413A 175Nm	BC	K0504072	KBR11/14G	KC355190L	Ø11	60	75	70	Ø14	38	4.5	23	9	M5x12	190.5			
	BC	K0504072	-	KC355190L	Ø14	60	75	70	Ø14	38	4.5	23	9	M5x12	190.5			
	BB	K0504073	-	KC355190L	Ø14	50	70	70	Ø14	38	4.5	23	9	M5x12	190.5			
	BE	K0504074	-	KC355190L	Ø14	80	100	85	Ø14	38	4.5	23	9	M6x12	190.5			
	BB	K0504073	-	KC355190L	Ø14	50	70	70	Ø14	38	4.5	23	9	M5x12	190.5			
	BE	K0504074	-	KC355190L	Ø14	80	100	85	Ø14	38	4.5	23	9	M6x12	190.5			
412A 175Nm	BC	K0634072	KBR14/22G	KC405190L	Ø14	60	75	90	Ø22	55.5	4.5	25	9	M5x12	186.5	243	260	
	BB	K0634073	KBR14/22G	KC405190L	Ø14	50	70	80	Ø22	55.5	4.5	25	9	M5x12	186.5	243	260	
513A 360Nm	BE	K0634074	KBR14/22G	KC405190L	Ø14	80	100	85	Ø22	55.5	4.5	25	9	M6x12	186.5	243	260	
	BF	K0634075	KBR19/22G	KC405190L	Ø19	95	115	100	Ø22	55.5	4.5	25	9	M8x12	186.5	243	260	
613A 530Nm	BG	K0634076	-	KC405190L	Ø22	110	145	130	Ø22	60.5	4.5	30	14	M8x14	191.5	248	265	
	BD	K0634078	KBR19/22G	KC405190L	Ø19	70	90	90	Ø22	55.5	4.5	25	9	M6x12	186.5	243	260	
512A 360Nm	BF	K0854075	KBR19/24G	KC505190L	Ø19	95	115	100	Ø24	58	4.5	26	9.5	M8x14	235.5		252	
	BG	K0854076	KBR22/24G	KC505190L	Ø22	110	145	130	Ø24	62	5	30	13.5	M8x14	239.5		256	
612A 530Nm	BH	K0854077	-	KC505190L	Ø24	130	165	140	Ø24	58	5	26	9.5	M8x14	235.5		252	
	BD	K0854078	KBR19/24G	KC505190L	Ø19	70	90	95	Ø24	58	4.5	26	9.5	M6x14	235.5		252	



Flanges for servomotors

Flange per servomotori

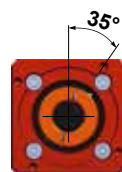

K0504072
Fixing holes shifted by 35°
Fori fissaggio motore ruotati a 35°

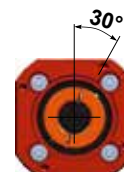

K0504073
K0634078
Fixing holes shifted by 30°
Fori fissaggio motore ruotati a 30°

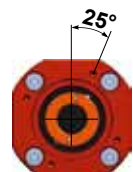

K0634072
K0634073
Fixing holes shifted by 25°
Fori fissaggio motore ruotati a 25°

SHAFT MOUNTED GEARBOXES

Flanges for servomotors - Flange per servomotori

Aluminum Compact-Gear

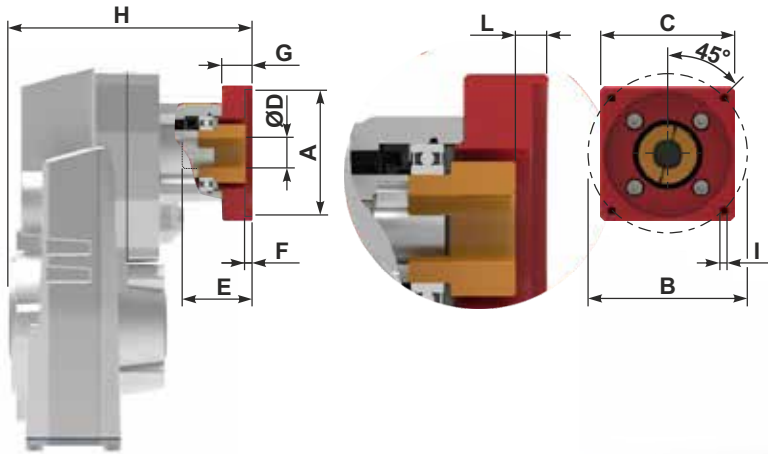

Type	Catalog Flange Code	Input Flanges Kit Code	Bushing Kit Code	Coupling Kit Code	Motor shaft Ø	A	B	C	ØD	E	F	G	L	I	H		
															FA33	FA43	
FA33 150Nm	BC	K0504072	KBR11/14G	KC355190L	Ø11	60	75	70	Ø14	38	4.5	23	9	M5x12	180	180	
	BC	K0504072	-	KC355190L	Ø14	60	75	70	Ø14	38	4.5	23	9	M5x12	180	180	
FA43 320Nm	BB	K0504073	-	KC355190L	Ø14	50	70	70	Ø14	38	4.5	23	9	M5x12	180	180	
	BE	K0504074	-	KC355190L	Ø14	80	100	85	Ø14	38	4.5	23	9	M6x12	180	180	
FA32 150Nm	BC	K0634072	KBR14/22G	KC405190L	Ø14	60	75	90	Ø22	55.5	4.5	25	9	M5x12	174.5	174.5	244
	BB	K0634073	KBR14/22G	KC405190L	Ø14	50	70	80	Ø22	55.5	4.5	25	9	M5x12	174.5	174.5	244
FA42 320Nm	BE	K0634074	KBR14/22G	KC405190L	Ø14	80	100	85	Ø22	55.5	4.5	25	9	M6x12	174.5	174.5	244
	BF	K0634075	KBR19/22G	KC405190L	Ø19	95	115	100	Ø22	55.5	4.5	25	9	M8x12	174.5	174.5	244
FA53 490Nm	BG	K0634076	-	KC405190L	Ø22	110	145	130	Ø22	60.5	4.5	30	14	M8x14	179.5	179.5	249
	BD	K0634078	KBR19/22G	KC405190L	Ø19	70	90	90	Ø22	55.5	4.5	25	9	M6x12	174.5	174.5	244
FA52 490Nm	BF	K0854075	KBR19/24G	KC505190L	Ø19	95	115	100	Ø24	58	4.5	26	9.5	M8x14	FA52		
	BG	K0854076	KBR22/24G	KC505190L	Ø22	110	145	130	Ø24	62	5	30	13.5	M8x14	235		
	BH	K0854077	-	KC505190L	Ø24	130	165	140	Ø24	58	5	26	9.5	M8x14	235		
	BD	K0854078	KBR19/24G	KC505190L	Ø19	70	90	95	Ø24	58	4.5	26	9.5	M6x14	235		

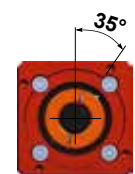
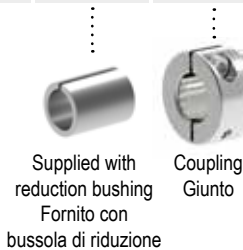

K0504072
Fixing holes shifted by 35°
Fori fissaggio motore ruotati a 35°

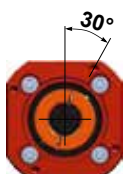

K0504073
K0634078
Fixing holes shifted by 30°
Fori fissaggio motore ruotati a 30°

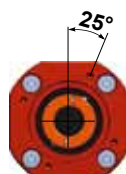

K0634072
K0634073
Fixing holes shifted by 25°
Fori fissaggio motore ruotati a 25°



Coupling tightening
Serraggio del giunto

SHAFT MOUNTED GEARBOXES

Flanges for servomotors - Flange per servomotori

Cast Iron **Compact-Gear**

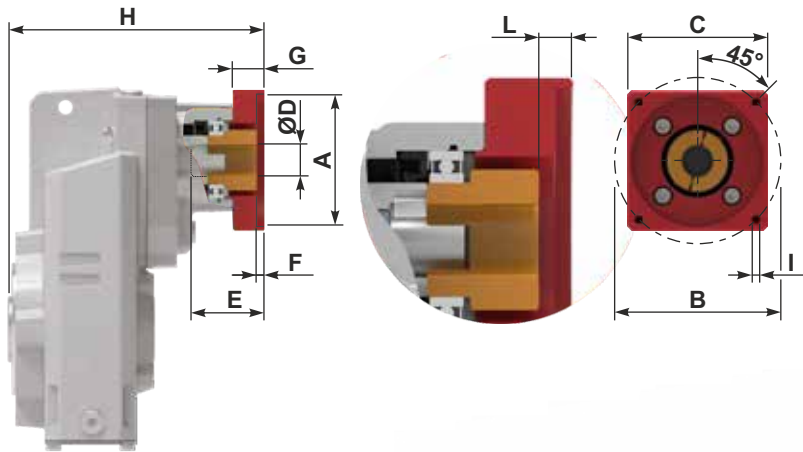

Type	Catalog Flange Code	Input Flanges Kit Code	Bushing Kit Code	Coupling Kit Code	Motor shaft Ø	A	B	C	ØD	E	F	G	L	I	H	
															FC63	FC73
FC63 675Nm	BC	K0634072	KBR14/22G	KC405190L	Ø14	60	75	90	Ø22	51.5	4.5	21	9	M5x12	244	255.5
	BB	K0634073	KBR14/22G	KC405190L	Ø14	50	70	80	Ø22	51.5	4.5	21	9	M5x12	244	255.5
	BE	K0634074	KBR14/22G	KC405190L	Ø14	80	100	85	Ø22	51.5	4.5	21	9	M6x12	244	255.5
FC73 900Nm	BF	K0634075	KBR19/22G	KC405190L	Ø19	95	115	100	Ø22	51.5	4.5	21	9	M8x12	244	255.5
	BG	K0634076	-	KC405190L	Ø22	110	145	130	Ø22	56.5	4.5	26	14	M8x14	249	260.5
	BD	K0634078	KBR19/22G	KC405190L	Ø19	70	90	90	Ø22	51.5	4.5	21	9	M6x12	244	255.5
FC62 675Nm	BF	K0854075	KBR19/24G	KC505190L	Ø19	95	115	100	Ø24	54	4.5	22	9.5	M8x14	235	246.5
	BG	K0854076	KBR22/24G	KC505190L	Ø22	110	145	130	Ø24	58	5	26	13.5	M8x14	239	251.5
FC72 900Nm	BH	K0854077	-	KC505190L	Ø24	130	165	140	Ø24	54	5	22	9.5	M8x14	235	246.5
	BD	K0854078	KBR19/24G	KC505190L	Ø19	70	90	95	Ø24	54	4.5	22	9.5	M6x14	235	246.5

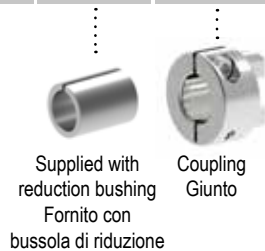

Reduction Bushing
Bussola di riduzione

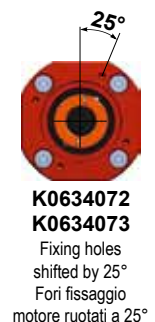
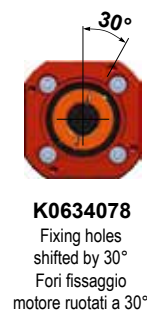

PARALLEL SHAFT GEARBOXES

Flanges for servomotors - Flange per servomotori

Cast Iron Cube-Gear

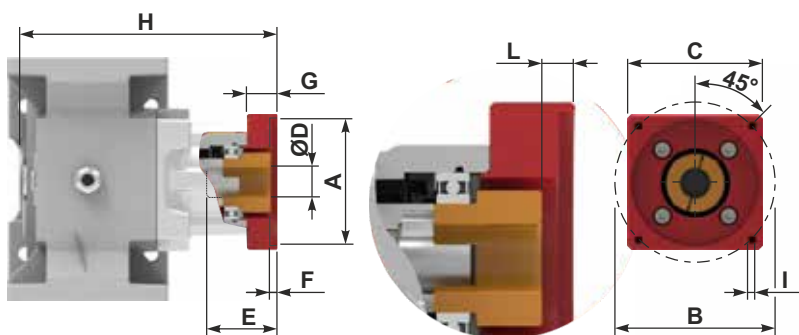

Type	Catalog Flange Code	Input Flanges Kit Code	Bushing Kit Code	Coupling Kit Code	Motor shaft Ø											H63C		H73C	
						A	B	C	ØD	E	F	G	L	I	H	H			
H63C 675Nm	BC	K0634072	KBR14/22G	KC405190L	Ø14	60	75	90	Ø22	55.5	4.5	25	9	M5x12	244	255.5			
	BB	K0634073	KBR14/22G	KC405190L	Ø14	50	70	80	Ø22	55.5	4.5	25	9	M5x12	244	255.5			
	BE	K0634074	KBR14/22G	KC405190L	Ø14	80	100	85	Ø22	55.5	4.5	25	9	M6x12	244	255.5			
H73C 900Nm	BF	K0634075	KBR19/22G	KC405190L	Ø19	95	115	100	Ø22	55.5	4.5	25	9	M8x12	244	255.5			
	BG	K0634076	-	KC405190L	Ø22	110	145	130	Ø22	60.5	4.5	30	14	M8x14	249	260.5			
	BD	K0634078	KBR19/22G	KC405190L	Ø19	70	90	90	Ø22	55.5	4.5	25	9	M6x12	244	255.5			
H62C 675Nm	BF	K0854075	KBR19/24G	KC505190L	Ø19	95	115	100	Ø24	58	4.5	26	22	M8x14	235	246.5			
	BG	K0854076	KBR22/24G	KC505190L	Ø22	110	145	130	Ø24	62	5	30	26	M8x14	239	250.5			
H72C 900Nm	BH	K0854077	-	KC505190L	Ø24	130	165	140	Ø24	58	5	26	22	M8x14	235	246.5			
	BD	K0854078	KBR19/24G	KC505190L	Ø19	70	90	95	Ø24	58	4.5	26	22	M6x14	235	246.5			

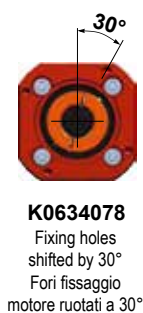

Flanges for servomotors
Flange per servomotori

HELICAL BEVEL GEARBOXES

Flanges for servomotors - Flange per servomotori

Aluminum Angletech-Gear

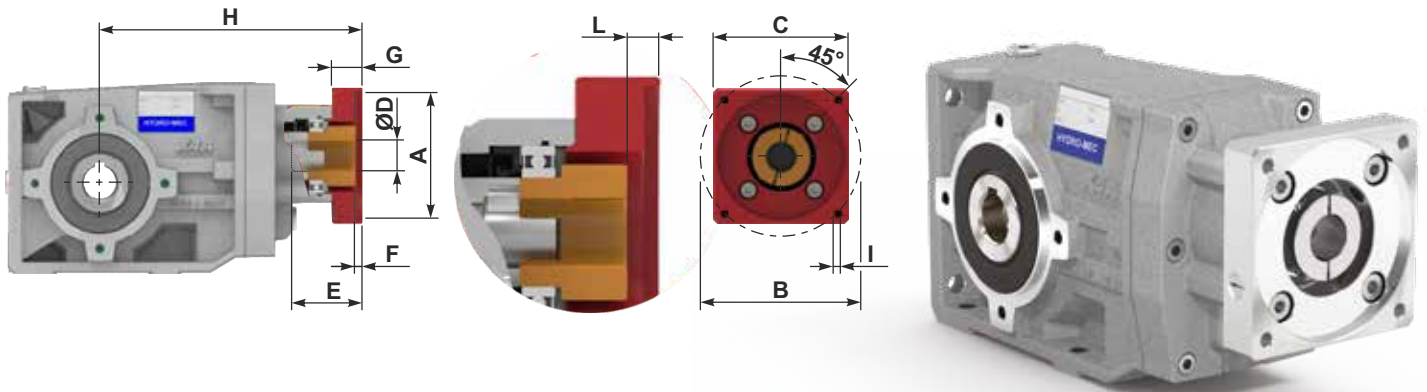

Type	Catalog Flange Code	Input Flanges Kit Code	Bushing Kit Code	Coupling Kit Code	Motor shaft \varnothing	A	B	C	$\varnothing D$	E	F	G	L	I	H			
															X22S	X33S	X43A	
X22S 50Nm	BC	K0504072	KBR11/14G	KC355190L	$\varnothing 11$	60	75	70	$\varnothing 14$	38	4.5	23	9	M5x12	159.5	194.5	210	
X33S 100Nm	BC	K0504072	-	KC355190L	$\varnothing 14$	60	75	70	$\varnothing 14$	38	4.5	23	9	M5x12	159.5	194.5	210	
X43A 160Nm	BB	K0504073	-	KC355190L	$\varnothing 14$	50	70	70	$\varnothing 14$	38	4.5	23	9	M5x12	159.5	194.5	210	
	BE	K0504074	-	KC355190L	$\varnothing 14$	80	100	85	$\varnothing 14$	38	4.5	23	9	M6x12	159.5	194.5	210	
															X32S	X42A	X53A	X63A
X32S 90Nm	BC	K0634072	KBR14/22G	KC405190L	$\varnothing 14$	60	75	90	$\varnothing 22$	55.5	4.5	25	9	M5x12	189	204.5	251	270
X42A 150Nm	BB	K0634073	KBR14/22G	KC405190L	$\varnothing 14$	50	70	80	$\varnothing 22$	55.5	4.5	25	9	M5x12	189	204.5	251	270
X53A 250Nm	BE	K0634074	KBR14/22G	KC405190L	$\varnothing 14$	80	100	85	$\varnothing 22$	55.5	4.5	25	9	M6x12	189	204.5	251	270
X63A 410Nm	BF	K0634075	KBR19/22G	KC405190L	$\varnothing 19$	95	115	100	$\varnothing 22$	55.5	4.5	25	9	M8x12	189	204.5	251	270
	BG	K0634076	-	KC405190L	$\varnothing 22$	110	145	130	$\varnothing 22$	60.5	4.5	30	14	M8x14	194	209.5	256	275
	BD	K0634078	KBR19/22G	KC405190L	$\varnothing 19$	70	90	90	$\varnothing 22$	55.5	4.5	25	9	M6x12	189	204.5	251	270
															X52A	X62A		
X52A 250Nm	BF	K0854075	KBR19/24G	KC505190L	$\varnothing 19$	95	115	100	$\varnothing 24$	58	4.5	26	9.5	M8x14	242		261	
	BG	K0854076	KBR22/24G	KC505190L	$\varnothing 22$	110	145	130	$\varnothing 24$	62	5	30	13.5	M8x14	242		265	
X62A 410Nm	BH	K0854077	-	KC505190L	$\varnothing 24$	130	165	140	$\varnothing 24$	58	5	26	9.5	M8x14	242		261	
	BD	K0854078	KBR19/24G	KC505190L	$\varnothing 19$	70	90	95	$\varnothing 24$	58	4.5	26	9.5	M6x14	242		261	

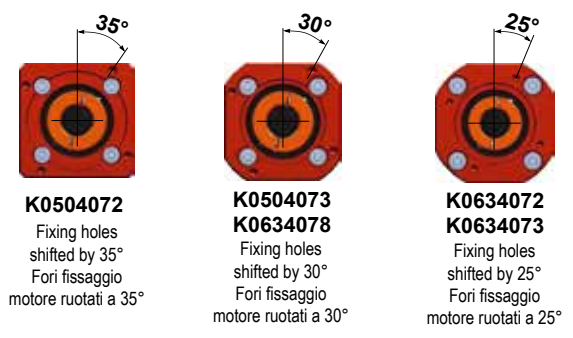
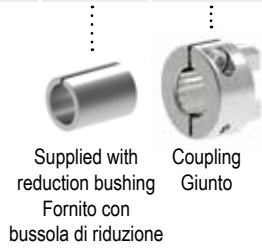

HELICAL BEVEL GEARBOXES

Flanges for servomotors - Flange per servomotori

Cast Iron Angletech-Gear

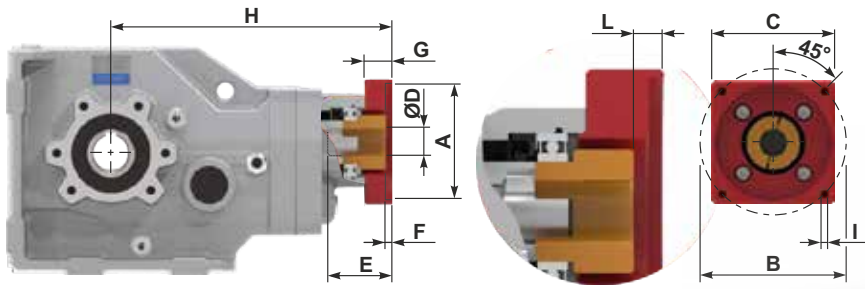

Type	Catalog Flange Code	Input Flanges Kit Code	Bushing Kit Code	Coupling Kit Code	Motor shaft Ø	A	B	C	ØD	E	F	G	L	I	H			
						X74C	X84C	114C	134C									
X74C 100Nm	BC	K0634072	KBR14/22G	KC405190L	Ø14	60	75	90	Ø22	55.5	4.5	25	9	M5x12	316	333	257.5	268
	BB	K0634073	KBR14/22G	KC405190L	Ø14	50	70	80	Ø22	55.5	4.5	25	9	M6x12	316	333	257.5	268
X84C 160Nm	BE	K0634074	KBR14/22G	KC405190L	Ø14	80	100	85	Ø22	55.5	4.5	25	9	M6x12	316	333	257.5	268
114C 250Nm	BF	K0634075	KBR19/22G	KC405190L	Ø19	95	115	100	Ø22	55.5	4.5	25	9	M8x12	316	333	257.5	268
	BG	K0634076	-	KC405190L	Ø22	110	145	130	Ø22	60.5	4.5	30	14	M8x14	321	338	262.5	273
134C 410Nm	BD	K0634078	KBR19/22G	KC405190L	Ø19	70	90	90	Ø22	55.5	4.5	25	9	M6x12	316	333	257.5	268
X73C 90Nm	BF	K0854075	KBR19/24G	KC505190L	Ø19	95	115	100	Ø24	58	4.5	26	9.5	M8x14	307	324	244.5	259
	BG	K0854076	KBR22/24G	KC505190L	Ø22	110	145	130	Ø24	62	5	30	13.5	M8x14	311	328	248.5	263
X83C 150Nm	BH	K0854077	-	KC505190L	Ø24	130	165	140	Ø24	58	5	26	9.5	M8x14	307	324	248.5	259
113C 250Nm	BD	K0854078	KBR19/24G	KC505190L	Ø19	70	90	95	Ø24	58	5	26	9.5	M6x14	307	324	248.5	259
133C 410Nm																		

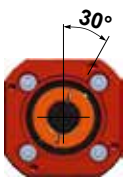

K0504073
K0634078
Fixing holes shifted by 30°
Fori fissaggio motore ruotati a 30°

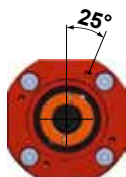

K0634072
Fixing holes shifted by 25°
Fori fissaggio motore ruotati a 25°



Coupling
Giunto

Available kits

Kit disponibili

Reduction bushings

Bussole di riduzione



Reduction bushing dimensions

Dimensioni bussola di riduzione

ØI	ØE	Code
Ø9	Ø14	KBR09/14G
Ø11	Ø14	KBR11/14G
Ø11	Ø19	KBR11/19G
Ø14	Ø19	KBR14/19G
Ø14	Ø22	KBR14/22G
Ø19	Ø22	KBR19/22G
Ø19	Ø24	KBR19/24G
Ø22	Ø24	KBR22/24G

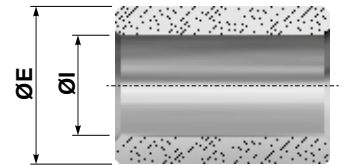

Couplings

Giunti



Coupling dimensions

Dimensioni giunto

Ød	ØD (min)	Code
Ø9	Ø34	K0305190L
Ø14	Ø40	KC355190L
Ø19	Ø42	K0505190L
Ø22	Ø48	KC405190L
Ø24	Ø57	KC505190L

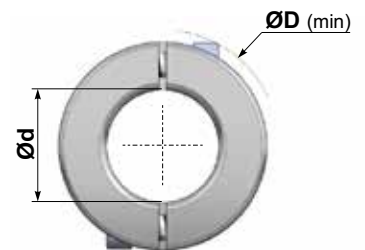

Flanges for servomotor

Flange per servomotore



Flange dimensions

Dimensioni flangia

Code Kit flange	A	B	C
K0304071	40	63	58
K0304072	60	75	70
K0304073	50	70	60
K0504072	60	75	70
K0504073	50	70	70
K0504074	80	100	85
K0504075	95	115	100
K0504078	70	90	80
K0634072	60	75	90
K0634073	50	70	80
K0634074	80	100	85
K0634075	95	115	100
K0634076	110	145	130
K0634078	70	90	90
K0854075	95	115	100
K0854076	110	145	130
K0854077	130	165	140
K0854078	70	90	95

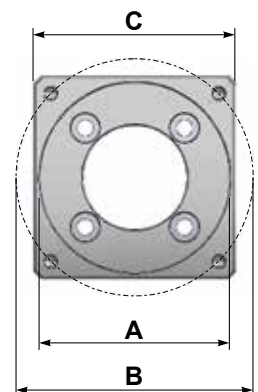

Instructions for motor assembly

Istruzioni per il montaggio del motore

1

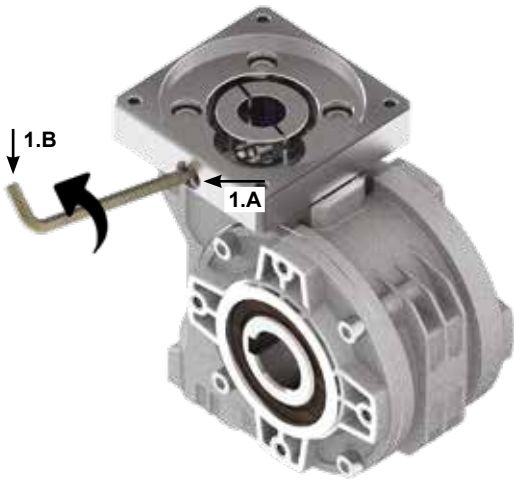

Remove the protection screws on the input flange.

Rimuovere le viti di protezione sulla flangia motore.

1.A



Loosen the fastening screws of the coupling.

Allentare le viti di serraggio del giunto.

1.B



2

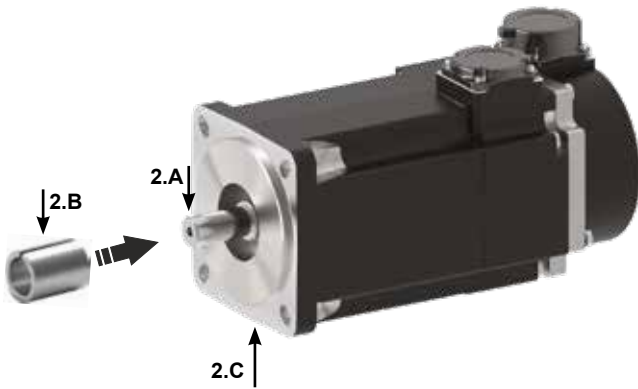

Motor shaft without key.

Albero motore senza linguetta.

2.A



Only if used with reduction bushing.

Mount the reduction bushing with the rubber hammer.

2.B

Se prevista la bussola di riduzione. Utilizzare un martello di gomma per il montaggio.



3

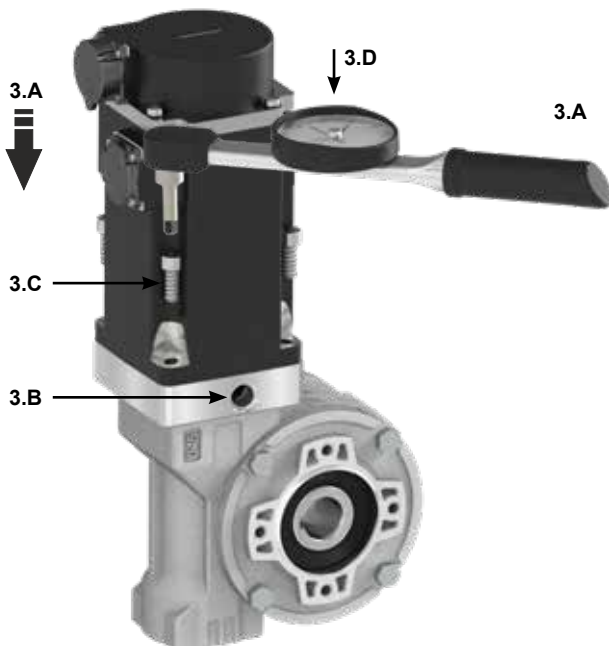

Clean the contact surface on the motor flange and input flange.

Pulire le superfici di contatto della flangia motore e flangia riduttore.

2.C



Place the gearbox with the hollow shaft that has to be connected with the motor (input shaft) facing up. The gearbox has to be without load and the output shaft has to be free to rotate.

Posizionare il riduttore con l'albero cavo di accoppiamento al motore (albero entrata) rivolto verso l'alto. Il riduttore non deve essere collegato a nessun carico e l'albero di uscita deve essere libero di ruotare.

3.A



Before mounting the motor, check aligned the screw is with the hole on the input motor flange.

Prima di montare il motore, assicurarsi che le viti del giunto sia allineata con il foro sulla flangia riduttore.

3.B



For fixing the motor, apply anti-loosening paste on screw thread, employ Arexons 52A70 strong thread lock or similar.

Per il fissaggio del motore, applicare un prodotto anti-svitamento sui filetti delle viti, utilizzare un frena filetto forte tipo Arexons 52A70 o similare.

3.C



Tighten the screws according to table torque values. Recommended the class screws 8.8.

Serrare le viti in base ai valori in tabella. Consigliato le viti di classe 8.8.

3.D

Screw Vite	TS [Nm]
M4	3
M5	6
M6	10
M8	25
M10	45

Instructions for motor assembly

Istruzioni per il montaggio del motore

4

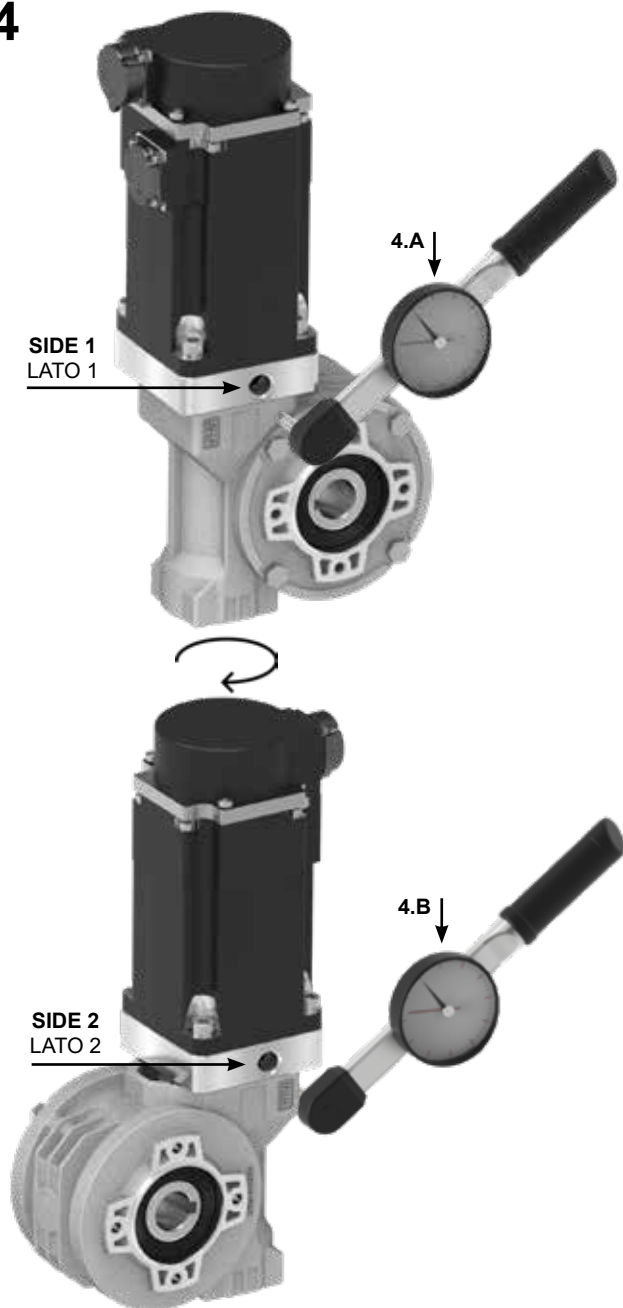

4.A

Tighten the screws (SC) according to the torque (TS) reported in the table.

(SC) Socked-head screw (Allen screw), class screws 8.8 .

Stringere le viti (SC) del giunto in base alla coppia di serraggio (TS) riportata nella tabella.

(SC) Vite a testa cilindrica esagono incassato (Brogola), classe 8.8 .

Coupling kit code	SC	TS [Nm]
K0305190L	M4x14	3.5
KC355190L	M4x14	3.5
K0505190L	M5x16	6
KC405190L	M5x16	6
KC505190L	M6x20	10



4.B

First tighten on side 1 and side 2, repeat the tightening a second round on both sides.

Stringere una prima volta sul lato 1 e sul lato 2, ripetere il serraggio una seconda volta su entrambi i lati.



CHECK

Exceeding the torque to fix the locking bolt can damage the coupling.

Il superamento della coppia di serraggio della vite di bloccaggio può danneggiare il dispositivo di accoppiamento



CHECK

5.A

Reset the protection screws.

Riposizionare le viti di protezione.

5

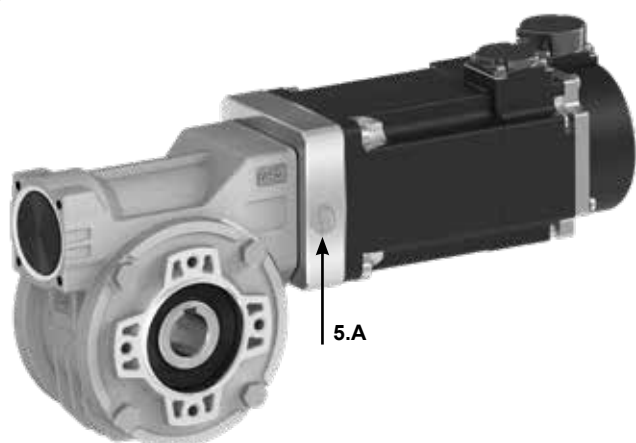

Aluminum IEC motors

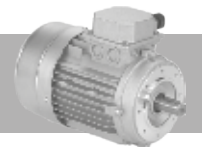

- 1) 230/400V - 50Hz three-phase asynchronous induction motor
- 2) Class F insulation
- 3) S1 duty
- 4) IP 55 protection
- 5) Not painted
- 6) Hard plastic sleeve to protect output shaft during the transportation

- 1) 230/400V - 50Hz motore trifase asincrono
- 2) Isolamento Classe F
- 3) S1 servizio continuo
- 4) Protezione IP 55
- 5) Non verniciato
- 6) Manicotto di protezione per l'albero motore

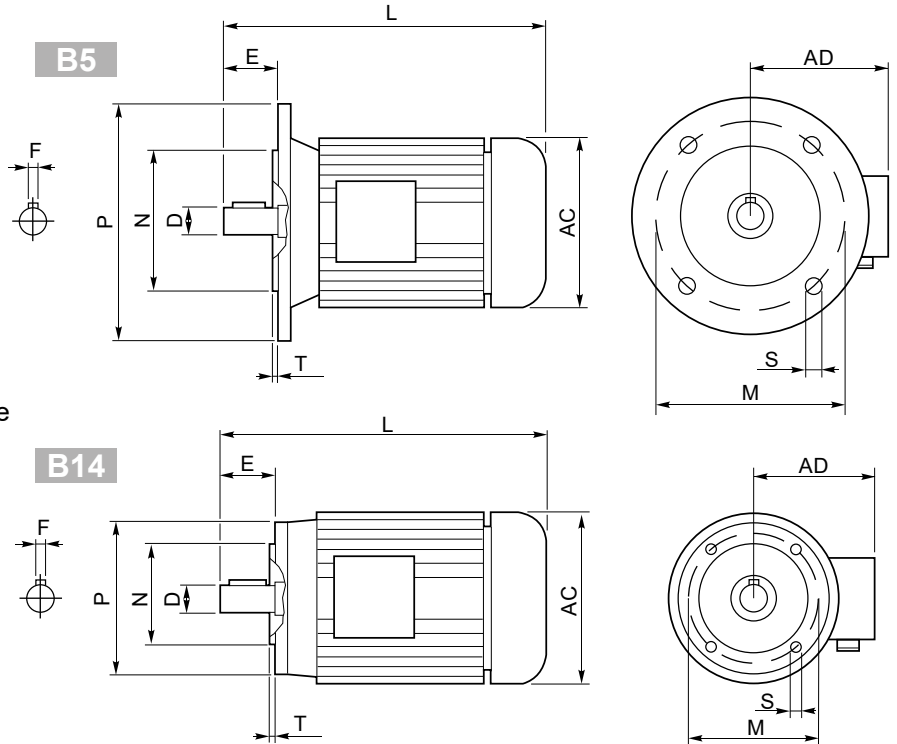

Outside dimensions and weight may be different according to manufacturers.
Le dimensioni esterne e il peso sono indicative, possono variare tra i vari costruttori.

	2 poli / poles			4 poli / poles			6 poli / poles			B5-B14					B5					B14					Kg	
	kW	Nm	A _(400V)	kW	Nm	A _(400V)	kW	Nm	A _(400V)	D	F	E	L	AC	AD	N	M	P	S	T	N	M	P	S		T
56 A	0.09	0.32	0.38	0.06	0.44	0.27	—	—	—	9	3	20	199	108	96	80	100	120	7	2.5	50	65	80	M5	2.5	2.7
56 B	0.12	0.42	0.46	0.09	0.67	0.37	—	—	—	9	3	20	199	108	96	80	100	120	7	2.5	50	65	80	M5	2.5	2.9
63 A	0.18	0.63	0.60	0.12	0.84	0.50	0.09	0.99	0.57	11	4	23	208	120	99	95	115	140	9.5	3	60	75	90	M5	2.5	3.8
63 B	0.25	0.87	0.76	0.18	1.30	0.69	0.12	1.32	0.74	11	4	23	208	120	99	95	115	140	9.5	3	60	75	90	M5	2.5	4.2
71 A	0.37	1.30	1.00	0.25	1.70	0.91	0.18	1.90	0.80	14	5	30	-	130	104	110	130	160	9.5	3.5	70	85	105	M6	2.5	5.9
71 B	0.55	1.90	1.54	0.37	2.52	1.14	0.25	2.72	1.10	14	5	30	255	141	107	110	130	160	9.5	3.5	70	85	105	M6	2.5	6.5
80 A	0.75	2.60	1.85	0.55	3.77	1.51	0.37	3.84	1.18	19	6	40	296	159	127	130	165	200	11.5	3.5	80	100	120	M6	3	8.5
80 B	1.1	3.90	2.64	0.75	5.11	2.57	0.55	5.84	1.80	19	6	40	296	159	127	130	165	200	11.5	3.5	80	100	120	M6	3	10
90 S	1.5	5.00	3.31	1.1	7.45	2.78	0.75	7.92	2.32	24	8	50	-	170	135	130	165	200	11.5	3.5	95	115	140	M8	3	12.5
90 L	2.2	7.50	4.46	1.5	10.2	3.61	1.1	11.6	3.45	24	8	50	330	170	135	130	165	200	11.5	3.5	95	115	140	M8	3	15
100 LA	3.0	10.0	6.28	2.2	14.8	5.07	1.5	15.4	3.88	28	8	60	-	190	148	180	215	250	13	4	110	130	160	M8	3.5	20
100 LB	—	—	—	3.0	20.1	6.66	—	—	—	28	8	60	-	190	148	180	215	250	13	4	110	130	160	M8	3.5	22
112 M	4.0	13.4	8.10	4.0	26.7	8.55	2.2	22.6	5.30	28	8	60	381	210	164	180	215	250	13	4	110	130	160	M8	3.5	35
132 S	5.5	18.3	11.2	5.5	36.5	11.4	3.0	30.2	7.20	38	10	80	455	244	180	230	265	300	14	4	130	165	200	M10	4	41
	7.5	24.9	15.3	5.5	36.5	11.4	3.0	30.2	7.20	38	10	80	455	244	180	230	265	300	14	4	130	165	200	M10	4	51
132 M	—	—	—	7.5	49.4	15.0	4.0	40.0	9.13	38	10	80	500	244	180	230	265	300	14	4	130	165	200	M10	4	51
	—	—	—	9	61.4	18.5	—	—	—	38	10	80	500	244	180	230	265	300	14	4	130	165	200	M10	4	51
160 M	—	—	—	11	72	21.5	—	—	—	42	12	110	613	335	246	250	300	350	18	5	—	—	—	—	—	79.2
	—	—	—	15	98	29	—	—	—	42	12	110	657	335	246	250	300	350	18	5	—	—	—	—	—	97.5
180 M	—	—	—	18.5	121	35.5	—	—	—	48	14	110	712	366	266	250	300	350	19	5	—	—	—	—	—	170
180 L	—	—	—	22	144	42	—	—	—	48	14	110	712	366	266	250	300	350	19	5	—	—	—	—	—	170
200 L	—	—	—	30	196	53	—	—	—	55	16	110	780	405	341	300	350	400	19	5	—	—	—	—	—	240
225 S	—	—	—	37	240	69	—	—	—	60	18	140	888	463	360	350	400	450	19	5	—	—	—	—	—	305
225 M	—	—	—	45	292	84	—	—	—	60	18	140	888	463	360	350	400	450	19	5	—	—	—	—	—	310

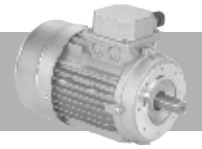

Protection

Standard IP55
Please specify on purchase orders if you need a higher IP protection class.

Grado di protezione

IP55 Standard
Specificare in sede di ordinazione per IP superiore.

Schutzart

IP55 Standard.
Höheren IP Grad bitte im Auftrag angeben.

Degré de protection

IP55 standard.
Au moment de la commande, spécifiez si vous souhaitez IP supérieur.

Grado de protección

IP55 standard.
Especificar en el pedido cuando necesiten protección IP superior.

Insulation

Standard CI.F
To be specified upon placing the order if different insulation is required.

Isolamento

CI.F Standard
Specificare in sede di ordinazione classe di isolamento diversa.

Isolierung

CI.F Standard.
Davon abweichende Isolierungsklasse im Auftrag angeben.

Isolement

CI.F Standard.
Au moment de la commande, spécifiez si vous souhaitez une classe d'isolement différente.

Aislamiento

CI.F standard.
Especificar al efectuar el pedido la clase diferente de aislamiento.

Insulation / Isolamento Isolierung /Aislamiento		E	B	F	H
Max. temp.	C°	120°	130°	155°	175°
	F*	248°	266°	311°	347°

Connections

Collegamenti

Verbindungselemente

Branchements

Conexiones

Threephase asynchronous single polarity
Asincrono trifase singola polarità
Asynchronmotor 3-ph eine Drehzahl
Moteur triphasé à une vitesse
Asincrono trifasico de una velocidad

Threephase asynchronous double polarity
Asincrono trifase doppia polarità
Asynchronmotor 3-ph doppelte Drehzahl
Moteur triphasé à deux vitesses
Asincrono trifasico de dos velocidades

Single phase asynchronous
Asincrono monofase
Einphasen-Asynchronmotor
Moteur monophasé
Asincrono monofasico

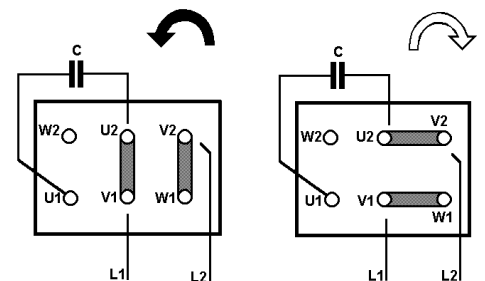
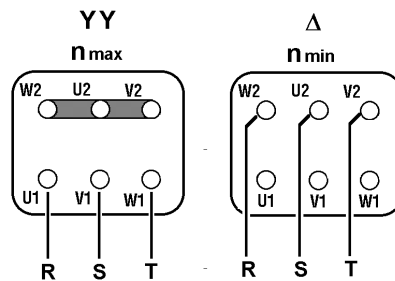
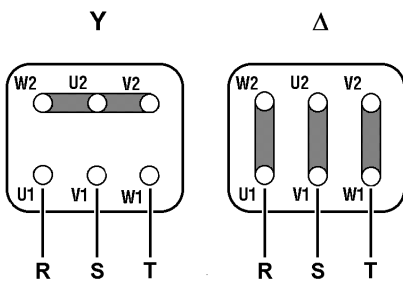

Quotations:

Unless differently agreed, the validity of all quotations is 2 months. The quotations are provided according to the RFQ (request for quotation) which shall contain the complete and detailed specification of the Product, the correctness of which is fully under responsibility of RFQ applicant.

Orders:

Only official orders issued on the Customer's letter-head are accepted. The Order Confirmation (OC) is issued within 2 working days from the order receipt unless the Products configuration issues arise. The OC shall be confirmed in writing within 2 working days from the OC date and in all its parts the product code and description, quantities and price, other specific information, if any. The OC is considered confirmed by tacit approval in case no written confirmation is provided by the Customer.

Production time:

An average production time for the standard Products is 3-4 weeks and 2-3 weeks for kits from the OC confirmation date and/or payment receipt in case of advanced payment term. For some configurations of the standard Products the production time can be different and shall be advised in the quotation and/or in any case in OC. In the period of Christmas holidays and August holidays the days of company closure are excluded from the abovementioned production term.

Delivery terms:

FCA Sovizzo, Italy (Incoterms 2016)

Packaging:

The products are packed in wooden boxes as a standard packaging. Europallets can be also used on request. The prices and details of the packaging are indicated in the apposite section of the Price List.

Payment terms:

The payment should be performed in terms indicated in the invoice and by wire transfer.

Prices:

The prices are indicated in the invoice and intended ex-works, unless differently specified, and do not include any kind of taxes, shipment or other type of costs.

Standard Products orders cancellation:

Modification or cancellation of the orders is accepted only if notified to Hydro-Mec S.p.A. in writing and not later than 3 days from the Order Confirmation and in any case before the production of the ordered Products is launched.

Special execution of customized products:

The Products that are not included in the catalogue or configurations of the products that can not be realized using catalogue, options and accessories brochure and/or online configurator (www.cleangeartech.com) are considered Customized Products.

(a) Hydro-Mec S.p.A. is entitled to examine feasibility of Special Execution of Customized Products and define the minimum quantity, production time and eventually other special sales and production conditions issuing thereafter a Special Execution Quotation that shall be confirmed by the Customer in writing.

(b) Once the Quotation is confirmed, Hydro-Mec S.p.A. shall realize a Special Execution (SE) data sheet with its unique code for each Customized product. The SE data sheet shall be confirmed in full and in writing by The Customer.

(c) The production time of SE is definitely settled by Hydro-Mec S.p.A. and notified to the Customer after the SE data sheet confirmation. As a rule, the production time for SE of Customized products is longer than standard.

(d) The orders of Special Execution of Customized products can not be cancelled unless special written agreement is made before the production of SE is launched.

WARRANTY Conditions:

(a) Warranty period is 12 months form the shipment date.

(b) Warranty period could be extended to 18 months prior written agreement of the parties and in any case excluding wearable parts.

(c) Warranty covers only manufacturing defects. Wearable parts (for example, oil seals or lubricants leakages caused by normal wear) and failures due to the wrong assembling by the Customer are not covered by warranty.

(d) This warranty is also void in any case in which the products have been misused, used in improper environment conditions, configurated beyond design limits indicated in the catalogue (especially service factor, loads and type of motors) or damaged, even accidentally or whenever installation instructions have not been strictly followed and in case of any natural disasters, in case of negligence of the Customer and the end user.

(e) The Customer is fully responsible to assure the compatibility of applications and correct mechanical couplings and electrical connections with the specifications of the Products according to Hydro-Mec S.p.A. catalogues and technical documentation

(f) The liability of Hydro-Mec S.p.A. is strictly limited to the above-stated obligations and it is therefore clearly agreed that Hydro-Mec S.p.A. take on no responsibility for any damage to persons and/or property deriving from accidents of any nature that may occur during use of the Products, whether the warranty is confirmed or otherwise, also in cases of the choice of the Product configuration being recommended by Hydro-Mec S.p.A.

WARRANTY Procedure:

(a) The Customer shall fill in the COMPLAINT FORM and forward it to Hydro-Mec S.p.A. along with other relevant information.

(b) Hydro-Mec S.p.A. examines the COMPLAINT FORM and confirms or declines the warranty.

(c) Hydro-Mec S.p.A. has the right to ask the Customer to send the malfunctioning product to Hydro-Mec S.p.A. for further examination. In case the warranty is not confirmed the Product will be shipped back to the Customer at the Customer expense. If the warranty is confirmed, Hydro-Mec S.p.A. shall compensate the shipment costs to the Customer within the limits of the best shipment quotation.

(d) In case the warranty is confirmed the Products shall be substituted at Hydro-Mec S.p.A. expense using ordinary shipment procedure. The express shipment can be used prior the agreement of the parties.

(e) In case the Product can not be substituted Hydro-Mec S.p.A. shall reimburse the value of the Product by issuing of Credit Note or in any other way agreed by the Parties.

WARNING (Please Read Carefully):

The following WARNING and CAUTION information is supplied to you for your protection and to provide you with many years of trouble free and safe operation of your product. Read ALL instructions prior to operating reducer. Injury to personnel or reducer failure may be caused by improper installation, maintenance or operation.

- (a) Written authorization is required to operate or use reducers in man lift or people moving devices.
- (b) Check to make sure that certain applications do not exceed the allowable load capacities published in the current catalog.
- (c) Buyer shall be solely responsible for determining the adequacy of the product for any and all uses to which Buyer shall apply the product. The application by Buyer shall not be subject to any implied warranty of fitness for a particular purpose.
- (d) For safety, Buyer or User should provide protective guards over all shaft extensions and any moving apparatus mounted thereon. The User is responsible for checking all applicable safety codes in his area and providing suitable guards. Failure to do so may result in bodily injury and/or damage to equipment.
- (e) Gearboxes operating in high position should have a protective shield for any possible parts falling down for casual accidents where people are moving under them.
- (f) Hot oil and reducers can cause severe burns. Use extreme care when removing lubrication plugs and vents.
- (g) Make certain that the power supply is disconnected before attempting to service or remove any components. Lock out the power supply and tag it to prevent unexpected application power.
- (h) Reducers are not to be considered fail safe or self-locking devices. If these features are required, a properly sized, independent holding device should be utilized. Reducers should not be used as a brake.
- (i) Any brakes that are used in conjunction with a reducer must be sized or positioned in such a way so as to not subject the reducer to loads beyond the catalog rating.
- (l) Lifting supports including eyebolts are to be used for vertically lifting the gearbox only and not other associated attachments or motors.
- (m) Use of an oil with an EP additive on units with backstops may prevent proper operation of the back-stop. Injury to personnel, damage to the reducer or other equipment may result.
- (n) Overhung loads subject shaft bearings and shafts to stress which may cause premature bearing failure and or shaft breakage from bending fatigue, if not sized properly.

Our company will not be responsible for any direct or indirect damages, caused by a wrong use of the products or for not observing the catalogue/web indication.

1) Definizioni

1.1 Ai fini delle presenti condizioni generali di vendita (di seguito denominate “Condizioni di Vendita”), i seguenti termini avranno il significato di seguito ad essi attribuito:

- “HM”: Hydro-Mec S.p.A.;
- “Cliente”: qualunque società, ente o entità giuridica che acquisti i Prodotti di HM da quest’ultima;
- “Prodotti”: i beni prodotti, assemblati e/o venduti da HM;
- “Ordine/i”: ciascuna proposta di acquisto dei Prodotti inoltrata dal Cliente ad HM esclusivamente tramite e-mail, fax o web;
- “Vendita/e”: ciascun contratto di vendita concluso tra HM e il Cliente a seguito del ricevimento da parte del Cliente dell’accettazione scritta dell’Ordine da parte di HM;

2) Scopi

2.1 Le presenti Condizioni di Vendita si applicano a tutte le Vendite di Prodotti. Nel caso di contrasto tra le condizioni e i termini di cui alle presenti Condizioni di Vendita e le condizioni e i termini pattuiti nella singola Vendita, quest’ultimi prevarranno. HM non sarà vincolata da condizioni generali di acquisto del Cliente (di seguito, “CGA”), neanche nell’ipotesi in cui si faccia loro riferimento o siano contenute negli ordini o in qualsiasi altra documentazione di provenienza del Cliente, senza il preventivo consenso scritto di HM. Le CGA non saranno vincolanti per HM neppure per effetto di tacito consenso.

2.2 HM si riserva il diritto di aggiungere, modificare o eliminare qualsiasi previsione delle presenti Condizioni di Vendita, restando inteso che tali aggiunte, modifiche o cancellazioni si applicheranno a tutte le Vendite concluse a partire dal trentesimo giorno successivo alla notifica al Cliente delle nuove Condizioni di Vendita.

3) Ordini e Vendite

3.1 Il Cliente dovrà inoltrare a HM Ordini specifici contenenti la descrizione dei Prodotti, la quantità richiesta, il prezzo ed i termini richiesti per la consegna.

3.2 La Vendita dovrà ritenersi conclusa: (i) nel momento in cui il Cliente riceva da parte di HM una conferma scritta (tale conferma potrà essere inviata via e-mail, fax o mezzi telematici) conforme ai termini e alle condizioni dell’Ordine (ii) o, nel caso in cui il Cliente riceva da parte di HM una conferma scritta contenente termini difformi da quelli contenuti nell’Ordine, decorsi tre giorni lavorativi dalla data di ricezione della conferma contenente termini difformi senza che nel suddetto periodo pervenga a HM contestazione scritta da parte del Cliente; (iii) o, in assenza di conferma scritta da parte di HM, nel momento in cui i Prodotti saranno consegnati al Cliente.

3.3 Gli Ordini regolarmente accettati da HM non potranno essere annullati dal Cliente senza il consenso scritto di HM.

4) Prezzo dei Prodotti

4.1 I prezzi dei Prodotti saranno quelli indicati nel listino prezzi di HM in vigore al momento dell'inoltro dell'Ordine da parte del Cliente o, qualora il Prodotto non sia inserito nel listino prezzi o il listino prezzi non sia disponibile, quelli indicati nell'Ordine e confermati per iscritto da HM al momento dell'accettazione dell'Ordine. Eccetto quanto diversamente concordato per iscritto tra le parti, i predetti prezzi saranno calcolati franco fabbrica, al netto dell'IVA e degli sconti. Tali prezzi non comprendono i costi di imballaggio, spedizione e trasporto dai locali di HM a quelli del Cliente. Tali costi dovranno essere sostenuti separatamente dal Cliente.

4.2 HM manterrà la proprietà dei Prodotti fino alla completa corresponsione del prezzo degli stessi. Il Cliente dovrà compiere tutti gli adempimenti richiesti dalle leggi locali al fine di rendere valida ed eseguibile nei confronti di tutti i terzi la presente clausola di riserva della proprietà anche operando l'iscrizione in ogni apposito registro, ove localmente richiesto.

5) Termini di consegna

5.1 Eccetto quanto eventualmente diversamente concordato per iscritto tra le parti, HM consegnerà i prodotti franco fabbrica presso i propri stabilimenti, così come questo termine è definito negli INCOTERMS 2010 pubblicati dalla Camera di Commercio internazionale nella loro versione più aggiornata, in vigore al momento della consegna. Se richiesto, HM si occuperà del trasporto dei Prodotti a rischio, costi e spese del Cliente.

5.2 La consegna dovrà avvenire entro il termine indicato nell'Ordine come accettato nella conferma d'ordine. I termini di consegna sono indicativi e non sono termini essenziali ai sensi dell'art. 1457 del Codice Civile e, in ogni caso, non includono i tempi di trasporto.

5.3 Salvo quanto previsto dal precedente art. 5.2, HM non sarà considerata responsabile dei ritardi o della mancata consegna ascrivibili a circostanze che siano fuori dal suo controllo, quali a titolo meramente esemplificativo e senza pretesa di esaustività:

- a) dati tecnici inadeguati o imprecisioni o ritardi del Cliente nella trasmissione a HM di informazioni o dati necessari alla spedizione dei Prodotti;
- b) difficoltà nell'ottenere rifornimenti delle materie prime;
- c) problemi legati alla produzione o alla pianificazione degli ordini;
- d) scioperi parziali o totali, mancanza di energia elettrica, calamità naturali, misure imposte dalle autorità pubbliche, difficoltà nel trasporto, cause di forza maggiore, disordini, attacchi terroristici e tutte le altre cause di forza maggiore;
- e) ritardi da parte dello spedizioniere.

5.4 Il verificarsi di alcuni degli eventi sopra elencati non darà diritto al Cliente di richiedere il risarcimento degli eventuali danni o indennizzi di alcun genere.

6) Trasporto

6.1 Eccetto quanto eventualmente diversamente concordato per iscritto tra le parti, il trasporto avverrà sempre a spese e rischio del Cliente. Nel caso in cui a HM, ai sensi dell'art. 5.1, venga richiesto di occuparsi del trasporto dei Prodotti, HM sceglierà il mezzo di trasporto che riterrà più appropriato in mancanza di specifiche istruzioni del Cliente.

7) Pagamenti

7.1 Salvo diverso accordo scritto tra le parti, HM emetterà le fatture al momento della consegna dei Prodotti.

7.2 Il mancato pagamento nel tempo concordato darà diritto a HM di chiedere al Cliente il pagamento degli interessi scaduti al tasso stabilito dal Decreto Legislativo n. 231/02.

7.3 Il mancato pagamento o il ritardo nei pagamenti superiore a 30 giorni daranno a HM il diritto di sospendere la consegna dei Prodotti e risolvere ogni singola Vendita sottoscritta. La sospensione della consegna dei Prodotti o la risoluzione delle Vendite non darà il diritto al Cliente di pretendere alcun risarcimento dei danni.

7.4 Ogni reclamo relativo ai Prodotti e/o alla consegna dei medesimi non potrà in alcun caso giustificare la sospensione o il ritardo nel pagamento.

8) Non-conformità

8.1 Qualsiasi difformità dei Prodotti consegnati al Cliente rispetto al tipo ed alla quantità indicata nell'Ordine dovrà essere denunciata per iscritto a HM entro cinque giorni dalla data di consegna. Qualora la denuncia non venga comunicata entro il predetto termine, i Prodotti consegnati verranno considerati come conformi a quelli ordinati dal Cliente.

9) Garanzia

9.1 Salvo diverso accordo scritto tra le parti, HM garantisce che i Prodotti sono esenti da vizi/difetti (con esclusione di quelle parti dei Prodotti che non sono prodotte da HM) per un periodo di 12 mesi decorrente dalla data di consegna dei medesimi al Cliente.

9.2 La garanzia non opererà con riferimento a quei Prodotti i cui difetti sono dovuti a

- danni causati durante il trasporto;
- un uso negligente o improprio degli stessi;
- inosservanza delle istruzioni di HM relative al funzionamento, manutenzione ed alla conservazione dei Prodotti;
- riparazioni o modifiche apportate dal Cliente o da soggetti terzi senza la previa autorizzazione scritta di HM.

9.3 A condizione che il reclamo del Cliente sia coperto dalla garanzia e notificato nei termini di cui al presente articolo, HM si impegnerà, a sua discrezione, a sostituire o riparare ciascun Prodotto o le parti di questo che presentino vizi o difetti.

9.4 Il Cliente dovrà denunciare per iscritto a HM, la presenza di vizi o difetti entro 8 giorni dalla consegna dei Prodotti se si tratta di vizi o difetti palesi, oppure, entro 8 giorni dalla scoperta in caso di vizi o difetti occulti o non rilevabili da una persona di media diligenza.

9.5 I Prodotti oggetto di denuncia dovranno essere immediatamente inviati presso la fabbrica di HM, o in qualsiasi altro luogo che quest'ultima indicherà di volta in volta, a costi e spese a carico del Cliente salvo diverso accordo tra le parti, al fine di consentire a HM l'espletamento dei necessari controlli. La garanzia non copre danni e/o difetti dei Prodotti derivanti da anomalie causate da, o connesse a, parti assemblate/aggiunte direttamente dal Cliente o dal consumatore finale. Qualora, nell'ambito della presente garanzia, un Prodotto o un componente difettoso venisse sostituito, la proprietà del Prodotto o del componente sostituito sarà ritrasferita dal Cliente a HM.

9.6 In ogni caso il Cliente non potrà far valere i diritti di garanzia verso HM se il prezzo dei Prodotti non sia stato corrisposto alle condizioni e nei termini pattuiti, anche nel caso in cui la mancata corresponsione del prezzo alle condizioni e nei termini pattuiti si riferisca a Prodotti diversi da quelli per i quali il Cliente intende far valere la garanzia.

9.7 HM non riconosce alcuna garanzia circa la conformità dei Prodotti alle norme e ai regolamenti di Paesi che non rientrano o non appartengono all'Unione Europea. Nessun'altra garanzia, espressa o implicita, quale, a titolo esemplificativo, la garanzia di buon funzionamento o di idoneità per uno scopo specifico, è concessa con riferimento ai Prodotti.

9.8 Senza pregiudizio a quanto indicato nel precedente art. 9.3 e salvo il caso di dolo o colpa grave, HM non sarà responsabile per qualsivoglia danno derivante e/connesso ai vizi dei Prodotti. In ogni caso, HM non sarà ritenuto responsabile per danni indiretti o consequenziali di qualsiasi natura quali, a titolo esemplificativo, le perdite derivanti dall'inattività del Cliente o il mancato guadagno.

10) Diritti di Proprietà Intellettuale

10.1 I Diritti di Proprietà Intellettuale sono di totale ed esclusiva proprietà di HM e la loro comunicazione o utilizzo nell'ambito delle presenti Condizioni di Vendita non crea, in relazione ad essi, alcun diritto o pretesa in capo al Cliente. Il Cliente si obbliga a non compiere alcun atto incompatibile con la titolarità dei Diritti di Proprietà Intellettuale.

11) Clausola risolutiva espressa

11.1 HM avrà facoltà di risolvere, ai sensi e per gli effetti dell'art. 1456 del Codice Civile Italiano, in qualsiasi momento mediante comunicazione scritta da inviare al Cliente, la singola Vendita nel caso di inadempimento delle obbligazioni previste dagli articoli: 4 (Prezzo dei Prodotti); 7 (Pagamenti); 10 (Diritti di Proprietà Intellettuale).

12) Mutamento nelle condizioni patrimoniali del Cliente

12.1 HM avrà diritto a sospendere l'adempimento delle obbligazioni derivanti dalla Vendita dei prodotti, in base all'art. 1461 del Codice Civile Italiano, nel caso in cui le condizioni patrimoniali del Cliente divenissero tali da porre in serio pericolo il conseguimento della controprestazione salvo che sia prestata idonea garanzia.

13) Domicilio legale, legge applicabile e giurisdizione

13.1 HM è legalmente domiciliata presso la sua sede principale.

13.2 Le Condizioni di Vendita e ogni singola Vendita saranno regolate e interpretate in conformità alla Legge Italiana.

13.3 Tutte le controversie derivanti da o connesse alle presenti Condizioni di Vendita e/o ad ogni Vendita saranno soggette alla esclusiva giurisdizione del Tribunale di Vicenza.

13.4 Salvo quanto pattuito nel precedente art. 13.3, HM si riserva il diritto, quando promotore di una azione legale in qualità di attore, di promuovere tale azione nel luogo di residenza del Cliente.

14) ATTENZIONE (Leggere attentamente):

Le seguenti raccomandazioni sono fondamentali per la vostra protezione e per garantirvi molti anni di sicuro funzionamento del vostro prodotto senza alcun problema.

Leggere attentamente tutte le istruzioni prima di azionare il riduttore. L'inappropriata installazione, manutenzione o funzionamento del riduttore può causare incidenti al personale addetto e danni al riduttore stesso.

14.1 E' richiesta autorizzazione scritta per azionare riduttori in ascensori o dispositivi per il movimento delle persone.

14.2 Controllare che alcune applicazioni non eccedano la massima capacità di carico ammessa pubblicata in questo catalogo.

14.3 L'acquirente è l'unico responsabile per la determinazione dell'adeguatezza del prodotto per qualcuna o tutte le utilizzazioni che l'acquirente stesso farà del riduttore. L'applicazione dell'acquirente non potrà essere soggetta ad alcuna implicita garanzia di montaggio per uno scopo particolare.

14.4 Per ragioni di sicurezza l'acquirente dovrà provvedere a porre protezioni adeguate su tutta la lunghezza dell'albero a tutti gli organi in movimento. L'utilizzatore è responsabile del controllo di tutti i codici di sicurezza e la predisposizione di protezioni adeguate. In assenza di tali precauzioni si possono verificare incidenti alle persone e danni agli apparati.

14.5 Su riduttori installati in posizioni elevate utilizzare protezioni adeguate per qualsiasi distacco accidentale di parti nel caso di passaggio di persone al di sotto.

14.6 Olio e riduttori bollenti possono causare gravi ustioni. Usare estrema cautela nella rimozione dei tappi e delle ventole.

14.7 Assicurarsi che la corrente di alimentazione sia scollegata prima di riparare o rimuovere alcun componente. Chiudere l'alimentazione e contrassegnare tale operazione per evitare accensioni accidentali.

14.8 I riduttori non devono essere considerati esenti da guasti o a bloccaggio automatico. Se sono indispensabili queste caratteristiche, deve essere utilizzato un dispositivo indipendente della dimensione adatta. I riduttori non devono essere utilizzati come freni.

14.9 Qualsiasi freno sia utilizzato insieme al riduttore deve essere della giusta grandezza e posizionato in modo da non causare carichi eccessivi non previsti dai dati forniti nel catalogo.

14.10 I dispositivi di sollevamento come le golfare devono essere usati solo per sollevare verticalmente il riduttore e non altri dispositivi associati o motori.

14.11 L'utilizzo di un olio con un additivo EP su gruppi provvisti di dispositivo di arresto possono inficiare l'uso corretto del freno e provocare danni alle persone, alle cose ed al riduttore stesso nonché ad altri apparecchi.

14.12 I Carichi sospesi assoggettano i cuscinetti della vite e la vite stessa a sollecitazioni che possono causare, se non adeguatamente dimensionati, l'usura prematura dei cuscinetti e/o la rottura della vite a causa della resistenza alla flessione.

La nostra ditta non si ritiene responsabile per eventuali danni diretti o indiretti derivanti da un uso improprio dei prodotti e dalla mancata osservanza delle indicazioni riportate a catalogo o web.

HYDRO-MEC

www.hydromec.com

Distributed from

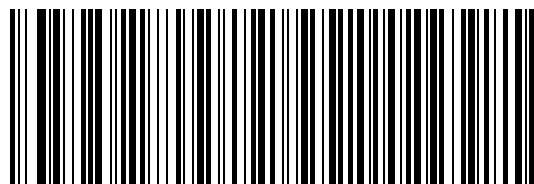

CT - GEMA - HM0 2 3 - ML